

Challenge Spartan 150M 15.75" Manual Heavy- Duty Paper Cutter

Instruction Manual



Provided by

MyBinding.com

When Image Matters.

Call Us at 1-800-944-4573

Serial Numbers 041001 & Up

TECHNICAL SERVICE AND PARTS MANUAL



SPARTAN 150 M ***DIGITAL/LEVER*** ***PAPER CUTTER***

Sold and Serviced by

The Challenge Machinery Company
6125 Norton Center Drive
Norton Shores, MI. 49441

www.challengemachinery.com



F.150M-T
Nov. 2004

When Image Matters.

1.0 Introduction

THIS MANUAL is designed to help you get the most from your Challenge equipment. Keep this manual in a safe, convenient place for quick reference by operators and service personnel.



CAUTION SAFETY ALERT! This symbol means **CAUTION: Personal safety instructions!** Pay special attention to the instructions in bold type. Personal injury may result if the precautions are not read and followed.

FOR PARTS AND SERVICE contact the Authorized Challenge Dealer from whom you purchased your machine. Use the illustrations and parts lists at the back of this manual to identify the correct parts needed. Always give the **SERIAL NUMBER** and **MODEL** of your machine to insure the correct parts are sent as soon as possible.

Challenge® is a registered trademark of
The Challenge Machinery Company • 6125 Norton Center Drive • Norton Shores, MI 49441-6081
Copyright© 2004 by The Challenge Machinery Company. All rights reserved. Printed in the U.S.A

TABLE OF CONTENTS

1.0 Introduction.....	2
2.0 Safety	4
2.1 Precautions	4
2.2 Power Lockout Procedure.....	4
2.3 Warning Label Definitions	5
3.0 Maintenance Guide	7
3.1 Routine Maintenance	8
3.1.1 Weekly	8
3.1.2 Monthly	8
3.1.3 Yearly.....	8
3.2 Cleaning	8
3.2.1 Table.....	8
3.2.2 Display Panel.....	8
3.2.3 Machine Exterior.....	9
3.3 Lubrication.....	9
3.3.1 Clamp.....	9
3.3.2 Backgauge Leadscrew	10
3.4 Adjustments	10
3.4.1 Squaring the Backgauge	11
3.4.2 Backgauge Accuracy Adjustment.....	12
3.4.3 Knife Bar Gib Adjustments	13
3.4.4 Knife Leveling Adjustment	14
3.4.5 Backgauge Gib Adjustments	16
3.4.6 Leadscrew Collars	16
3.4.7 Line-Light Adjustment.....	17
3.4.8 Backgauge Encoder/Belt Adjustment.....	18
3.5 Hood and Knife Latch Adjustments.....	19
3.5.1 Knife Latch Replacement.....	20
3.6 Troubleshooting	21
4.0 Parts Lists.....	22
4.1 Main Assembly – Backgauge Bracket	22
4.2 Main Assembly – Clamp	24
4.3 Main Assembly – Knife Drive	26
4.4 Main Assembly – Backgauge.....	28
4.5 Main Assembly – Top Cover	30
4.6 Main Assembly – Hood	31
4.7 Main Assembly – Electrical	32
4.8 Main Assembly – Encoder Mount	34
4.9 Main Assembly – Preset	36
4.10 Backgauge Assembly	37
4.11 Interconnection Diagram.....	38
4.12 Label- Electrical.....	39
4.13 Label – Caution.....	39
4.14 Optional Floor Stand Assembly	40
4.15 Knife Latch Replacement Kit.....	41

2.0 Safety

2.1 Precautions

- This machine is designed for one-person operation. Never operate the machine with more than one person.
- Safe use of this machine is the responsibility of the operator. Use good judgment and common sense when working with and around this machine.
- Read and understand all instructions thoroughly before using the machine. If questions remain, contact the dealer from which you purchased this machine. Failure to understand the operating instructions may result in personal injury.
- Only trained and authorized people should operate this machine.
- **DO NOT ALTER SAFETY GUARDS OR DEVICES.** They are for your protection. Severe personal injury may result.
- **Disconnect power** before cleaning or performing maintenance. See Section 2.2 Power Lockout Procedure.
- Observe all caution labels on this machine.
- Be sure the cutter is properly grounded.
- Be sure there is sufficient power to operate the cutter properly.
- Observe all caution plates mounted on this cutter.
- Keep foreign objects off table and away from cutter blade.
- **BE EXTREMELY CAREFUL** when handling and changing the cutter knife. Severe lacerations or dismemberment could result from careless handling procedures.
- Keep the floor around the cutter free of trim, debris, oil and grease.
- When replacing hydraulic parts, loosen the connections slowly to release pressure. Never loosen connections with the machine running.
- If the cutter sounds or operates unusually, have it checked by a qualified service person.
- **CRUSH HAZARD**, keep hand and fingers from under the clamp when clamping paper. Use Jogging Aid to load paper, and use the backgauge to push paper out before unloading. **DO NOT REACH UNDER THE KNIFE AND CLAMP AREA!**

2.2 Power Lockout Procedure

For maximum safety while making adjustments or repairs to your machine, be sure to disconnect power to the machine. Disconnect the power plug from its socket

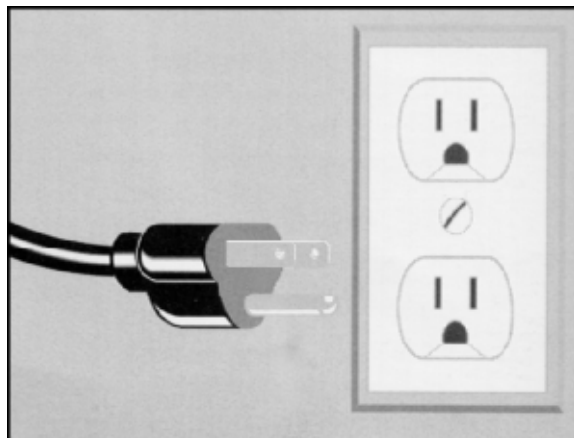

Figure 1 - Main Power Disconnect

2.3 Warning Label Definitions

The following warning labels are found at various locations on your machine. Read and understand the meaning of each symbol. If a label is lost from the machine, it should be replaced.



HAZARDOUS AREA

Disconnect power before cleaning, servicing, or making adjustments not requiring power. Do not alter safety guards or devices; they are for your protection. Replace all guards. Do not operate with any guards removed.

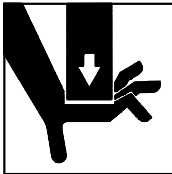

CUT/CRUSH HAZARD

Keep hands from underneath the knife and clamp.



SINGLE OPERATOR

Do not operate with more than one person.

!OJO!



CAUTION This Este simbolo de alerta de seguridad significa ¡ OJO ! - INSTRUCCIONES DE SEGURIDAD PERSONAL. Lea las instrucciones porque se refieren a su seguridad personal. Fall de obedecer las instrucciones que siguen podria resultar en lesiones corporales.

- Esta maquina, junto con sus mecanismos de seguridad, esta disenada para ser manejada por
- **UNA SOLA PERSONA** a la vez. Jamas debe ser manejada por mas de una persona al mismo tiempo.
- La seguridad es la responsabilidad del operario que usa esta maquina.
- **LEA DETENIDAMENTE** el manual de instrucciones y las **PRECAUCIONES DE SEGURIDAD** antes de poner a funcionar la cortadora. Pidale a su supervisor una copia.
- El manejo de la guillotina debe estar exclusivamente a cargo de personal entrenado y autorizado para ello.
- **NO MODIFIQUE LOS MECANISMOS DE SEGURIDAD**, estan ahi para su proteccion no deben ni modificarse ni quitarse.
- **DESCONECTE LA CORRIENTE ELECTRICA** antes de proceder a hacerle servicio de limpieza, engrasar, o de hacer ajustes que no requieren corriente. Trabe el interruptor en la posicion **OFF** (apagado); vea "Procedimiento para cortar la corriente electrica" al pie de esta pagina.
- Eche llave a la guillotina y quite la llave cuando la maquina no esta en operacion; vea "Corriente electrica".
- Asegurese de que la guillotina este debidamente a tierra. Vea "Conexion de la fuerza electrica".
- Verifique el voltaje y asegurese de que este sea suficiente para el debido funcionamiento de la guillotina.
- Preste atencion a todas las placas con advertencias instaladas en esta guillotina.
- No permita que objetos estranos esten en la mesa o cerca de la cuchilla cortadora.
- **TENGA SUMO CUIDADO** al tocar y cambiar la cuchilla. Heridas severas y hasta desmembramiento pueden resultar del manejo sin cuidado o negligente.
- El suelo alrededor de la guillotina debe mantenerse despejado y libre de recortes, desperdicios, aceite y grasa.
- Al haber la necesidad de reemplazar partes hidraulicas, afloje todas las conexiones poco a poco para dejar escapar la presion. Jamas debe aflojarse conexiones mientras la maquina este andando.
- Si la guillotina empezara a sonar o trabajar diferentemente a lo acostumbrado, desconectela y consulte la seccion "Troubleshooting" (Reparador) de este manual. Si no es posible corregir el problema, llame a su servicio autorizado para que le examinen la maquina.
- **PELIGRO DE MACHUQUE** - Mantenga manos y dedos fuera de la agarradera mientras sujeta el papel. Use el calibrador trasero y su rueda de mano para empujar el papel cortado. **NO PONGA SUS MANOS BAJOLA CUCHILLA O AREA DE LA AGARRADERA.**
- **NO OPERE SIN LAS GUARDAS PROTECTORAS!**

¡ OJO ! PRECAUCION - Como proceder para desconectar la corriente electrica.

Para maxima seguridad durante ajustes y reparaciones de su maquina, verifique bien que el interruptor principal de control de corriente al cual la maquina esta conectada, este desconectado. El interruptor deba ser puesto en la posicion "OFF" (desconectado) y se debe poner un candado en la anilla. La llave del candado debe ser guardada por la persona que estara efectuando los trabajos de servicio o de reparacion en la guillotina.

Desconecte la corriente electrica antes de proceder a hacer cualquier ajuste o reparacion o de efectuar el engrase en cualquier maquina.

3.0 Maintenance Guide

⚠ NOTICE ⚠

The instructions on the following pages are for the use of trained service personnel only!

Attempting to perform repair and replacement procedures without proper training may cause machine damage or operator injury!

PARTS CUSTOMERS: The Challenge Machinery Company provides parts with the express understanding that they are to replace parts found missing or no longer serviceable on equipment designed and/or manufactured by Challenge. The Challenge Machinery Company assumes no liability for any modification or alteration to any Challenge products, and any such modification or alteration to any Challenge product is not authorized by The Challenge Machinery Company. Any modification or alteration of any Challenge product will void any remaining warranty.

3.1 Routine Maintenance



CAUTION DISCONNECT POWER before making any adjustments or lubricating. See page 4, SAFETY PRECAUTIONS, for Power Lockout Procedure.

A clean, lubricated machine will run longer, smoother, cut more accurately, with less downtime and fewer costly repairs. Schedule lubrication both early in the day and early in the week. This allows the lubricants to work into the machine. Lubrication at the end of the day or week allows the lubricants to run off without as much benefit to the machine. The following guidelines will help you set up a regular maintenance schedule:

3.1.1 Weekly

- **Clean** — Clean off old, dirty excess grease. Remove the top cover and clean accumulated dust off knife bar and gib areas. Built-up dust can increase wear to components.
- **Hardware** — Remove top cover to check all nuts and bolts for tightness. Loose hardware is the cause of most component wear and in the electrical area could cause short circuits and/or shock.
- **Lubrication** — See section 3.3 page 9

3.1.2 Monthly

- **Backgauge Squaring** — See section 3.4.1 page 11

3.1.3 Yearly

- **Knife Bar Gib Adjustment** — See section 3.4.3 page 13
- **Backgauge Accuracy Adjustment** — See Section 3.4.2 page 12

3.2 Cleaning

Before cleaning inside machine, disconnect power cord.

3.2.1 Table

- The front table should be wiped down periodically. Use a non-abrasive cleaner along with a protective wax.
- The rear table cover and front shield may be cleaned with glass cleaner or a mild water based detergent. Some petroleum-based solvents may damage the Plexiglas.

3.2.2 Display Panel

- The display panel should be cleaned with a mild water based detergent applied to a damp cloth or paper towel. Petroleum based solvents **will** damage the display.

3.2.3 Machine Exterior

- The machine's exterior should be cleaned with a non-abrasive water based detergent applied to a damp cloth.
- Always be careful when cleaning around safety warning labels. Use limited amounts of cleaners in those areas.

3.3 Lubrication

3.3.1 Clamp

Move the knife and clamp down. Disconnect the power cord and remove clamp handle, cutting lever handle, and top cover. Wipe off any old or excess grease. Apply grease and oil to the areas shown in Figure 2, Figure 3, and Figure 4 below.

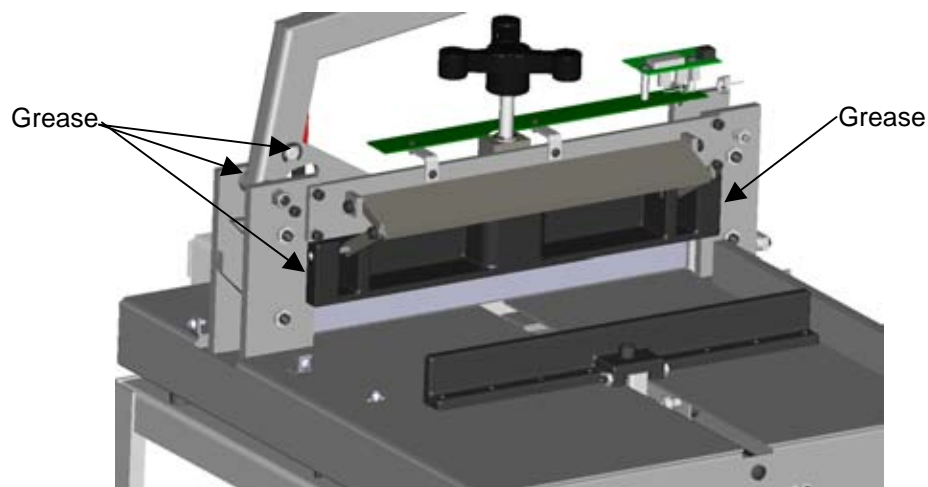

Figure 2

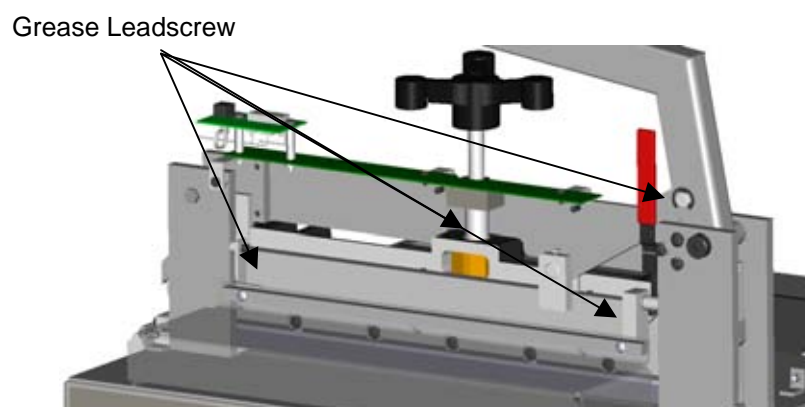

Figure 3

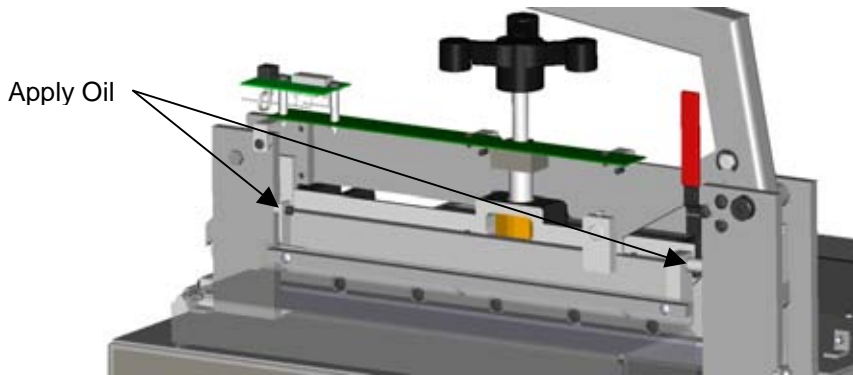

Figure 4

3.3.2 Backgauge Leadscrew

With the top cover ON, place machine on a flat level surface on it's left side. Use any brand-name type of grease or light oil to lubricate backgauge leadscrew (Figure 5). It may be helpful to use a small brush to apply grease. Note: the leadscrew may be lubricated with grease or oil. Oil has a tendency to run off and must be lubricated more frequently; grease tends to collect paper dust and must be cleaned off periodically.

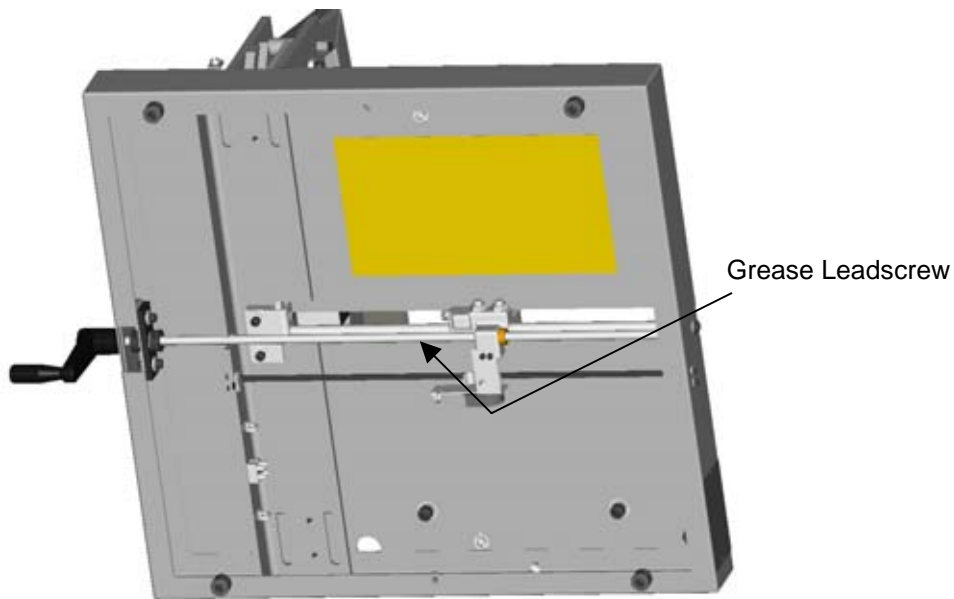

Figure 5

3.4 Adjustments

CAUTION Some of the following tests require the machine to be operational for checking and adjusting. Be very careful that tools and other people are clear of moving parts and that the cutter is not accidentally operated while adjustments are being made. Whenever possible, disconnect the power and lock it out (see SAFETY PRECAUTIONS, page 4) unless the directions specifically require the machine to be powered.

3.4.1 Squaring the Backgauge

To test if the backgauge is square, place a small lift of paper against the left side of the backgauge (but not against the side guide) and make a cut. Leave the backgauge in the same position, flip the lift over and push it against the right side of the backgauge (but not against the side guide). Make another cut to see if any of the paper will trim off (Figure 6). Run two checks, one starting on the left and moving to the right; the other, moving from the right to the left. If paper is trimmed in either sequence, the backgauge is out of square.

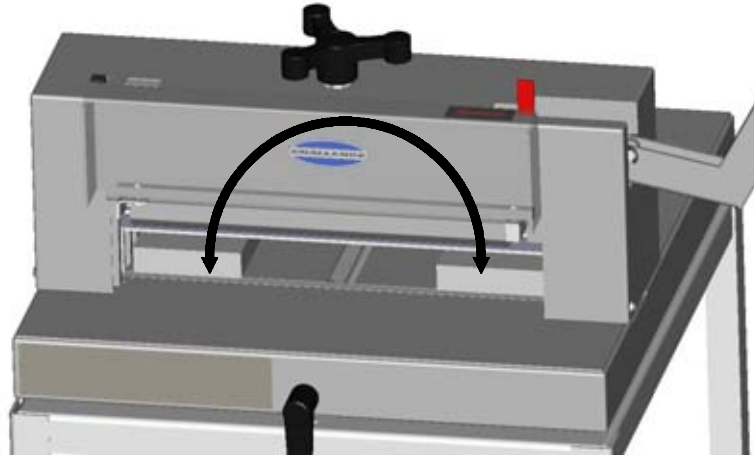

Figure 6

To square the backgauge:

1. Make sure the backgauge gibs are set properly (see section 3.4.5).
2. Loosen the jam nuts on the backgauge adjusting screws. (Figure 7).

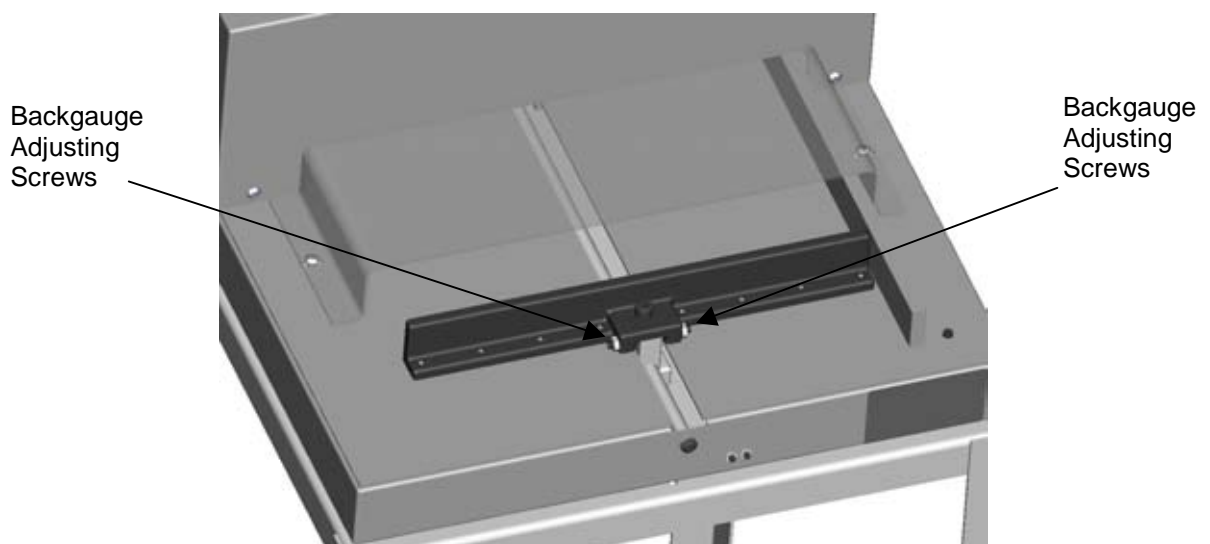

Figure 7

3. Back off the adjusting screw on the side that the trim occurred, then tighten the other screw.

4. With the squaring screws tight, make another test. Continue to adjust and test until no trim occurs when testing either sequence.

Note: Once the backgauge is square, check the backgauge accuracy (see section 3.4.2) to make sure it is accurate.

3.4.2 Backgauge Accuracy Adjustment

If the backgauge position readout does not match the actual measurement between the knife and the backgauge, the accuracy can be adjusted. The accuracy can be checked by the following procedure:

NOTE: The backgauge should be squared before attempting to adjust the accuracy. (See Section 3.4.1 Squaring the Backgauge, page 11.)

1. Place a 1/4 to 1/2" lift of 8-1/2 x 11 " paper against the center of the backgauge.
2. Using the backgauge position readout, bring the lift up to the 10.00" position and make a cut. Then move the backgauge up to 5.00" and make another cut.
3. Take a sheet from the center of each lift and compare them to each other. The cutter will always space accurately between cuts (in this case the 10" and 5" cuts) whether the overall accuracy is correct or not (Figure 8). The front stack will be a true 5", but the paper left against the backgauge will not be if the backgauge position is inaccurate.

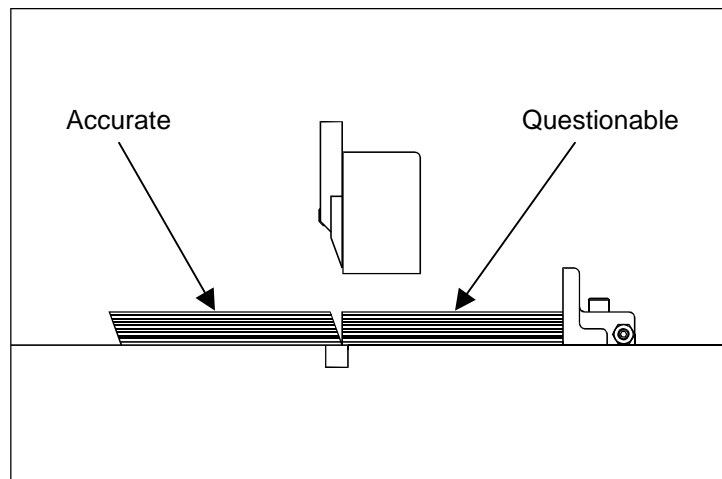

Figure 8

4. The backgauge accuracy can be corrected by adjusting the preset screw attached to the bottom of the backgauge nut assembly (Figure 9). Disconnect the power cord. With the top cover ON, place the machine on a flat level surface on it's left side. Place a 5/16" wrench in the preset screw and hold in position while loosening the jam nut. Adjust the screw as follows:
 - If test pile is short (back pile is less than 5"), turn screw out (counterclockwise).
 - If test pile is long (back pile is more than 5"), turn screw in (clockwise).

1/4 turn = .010" backgauge adjustment
1/3 turn = .014" (9/64")

1/2 turn = .021" (7/32")
2/3 turn = .028" (9/32")
1 turn = .042" (13/32")

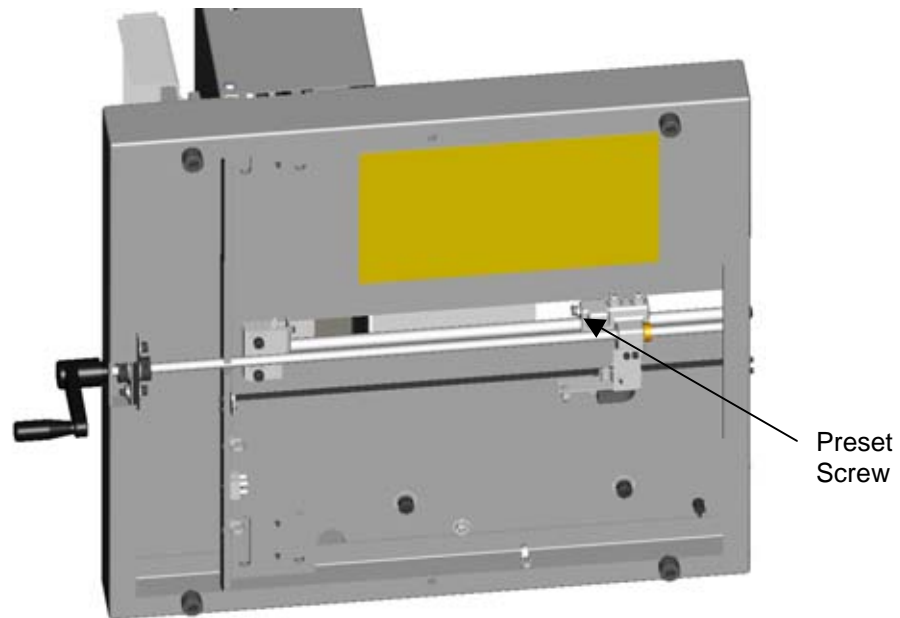

Figure 9

5. Lay the machine flat, and connect power. Note: If power was not off, reset power, otherwise the reading will be false. Bring the backgauge to the front to reset the display and make another test. Repeat adjustment procedure if necessary.

3.4.3 Knife Bar Gib Adjustments

1. Make sure the knife is in up position and disconnect the power cord.
2. Lower the clamp to the table. Remove clamp handle, cut lever handle, and top cover.
3. Loosen the gib screw jam nuts on each side (Figure 10).

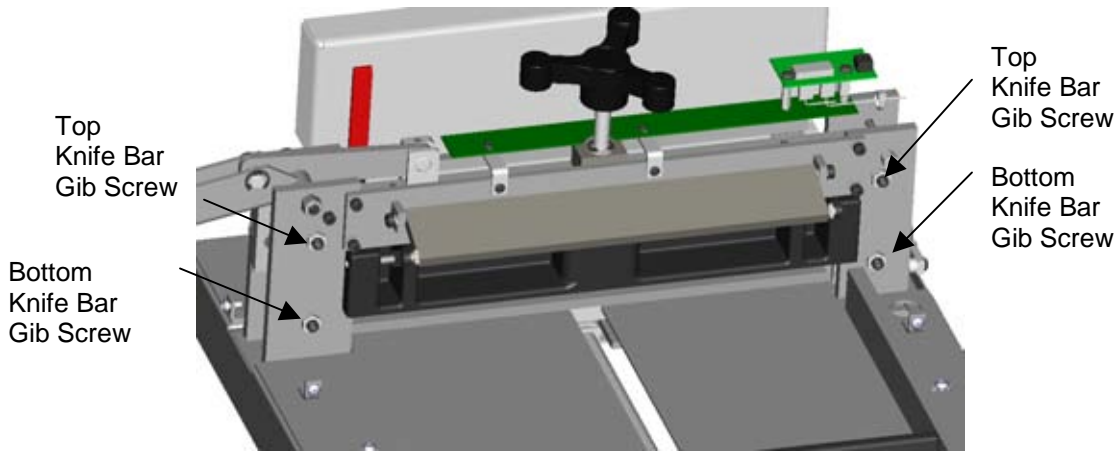

Figure 10

4. Tighten gib screws such that the knife will not fall when the lever is released from any position. Tighten the top screws with the knife in the UP position. Tighten the bottom screws with the knife in the DOWN position. The motion of the lever should remain smooth. Hold screws in position with hex wrench and tighten jam nuts.
5. Reinstall clamp handle, cut lever handle, and top cover.

3.4.4 Knife Leveling Adjustment

If knife cuts through one side of paper and not the other, the knife level may need adjustment. First check to make sure the knife is all the way up in knife bar by looking through the viewing holes in the knife bar (Figure 11). If it is not all the way up, loosen the knife screws and use knife lifter assembly to raise knife up as high as possible. Recheck knife by cutting through paper.

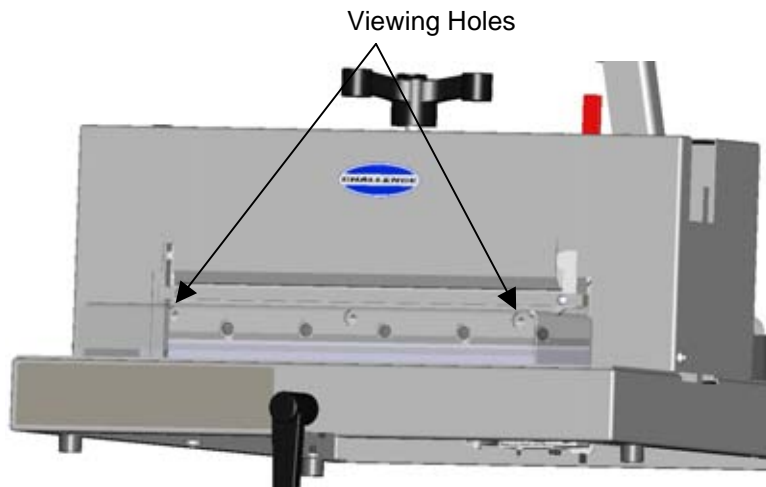

Figure 11

If knife is not cutting through paper evenly, use the following procedure to adjust:

1. Flip the cut stick to a new position.
2. Place a few sheets of paper over the entire cut stick, and set the knife depth so that it just cuts through the bottom sheet of paper on one side. To set the knife to cut deeper, turn the

adjustment screw counter-clockwise. To set the knife to cut shallower, turn the screw clockwise (Figure 12).

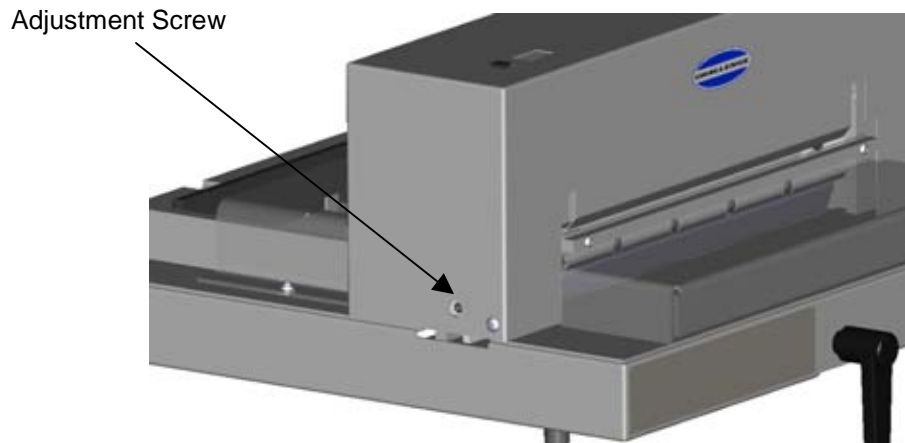

Figure 12

3. Note which side is not cutting completely through the paper. Lower the clamp to the table with partially cut paper underneath.
4. Lower the clamp to the table. Remove the clamp handle, cutting lever handle, and top cover.
5. Slightly loosen the knife screws, keeping them somewhat snug.
6. Adjust the knife leveling screw (Figure 13) that corresponds with the side of the knife that does not cut completely through. Re-tighten all screws and cut again. Continue adjustment until sheets are cut completely through without great effort.

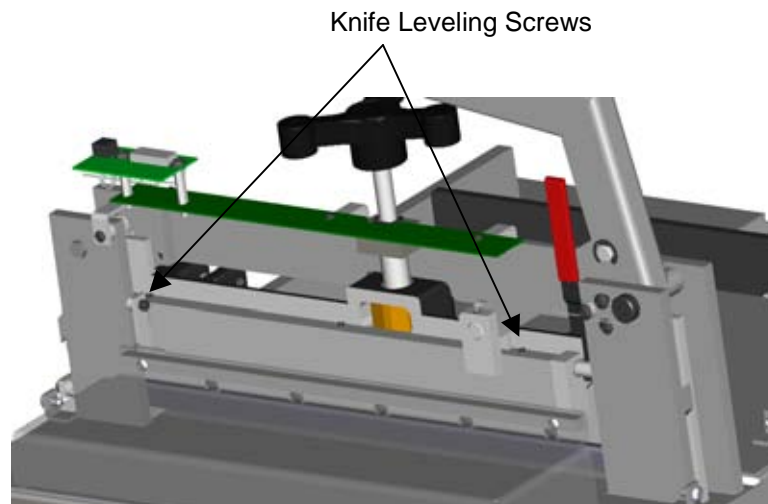

Figure 13

7. Tighten the knife bolts and reinstall the top cover, cutting lever handle, and clamp handle.

3.4.5 Backgauge Gib Adjustments

If the backgauge does not stay square or moves up and down or back and forth when jogging paper against it, the backgauge gib screws may be loose or worn.

To Adjust:

1. Disconnect the power cord.
2. Place machine on a flat level surface on it's left side.
3. Loosen the two gib screw jam nuts (Figure 14, page 16).

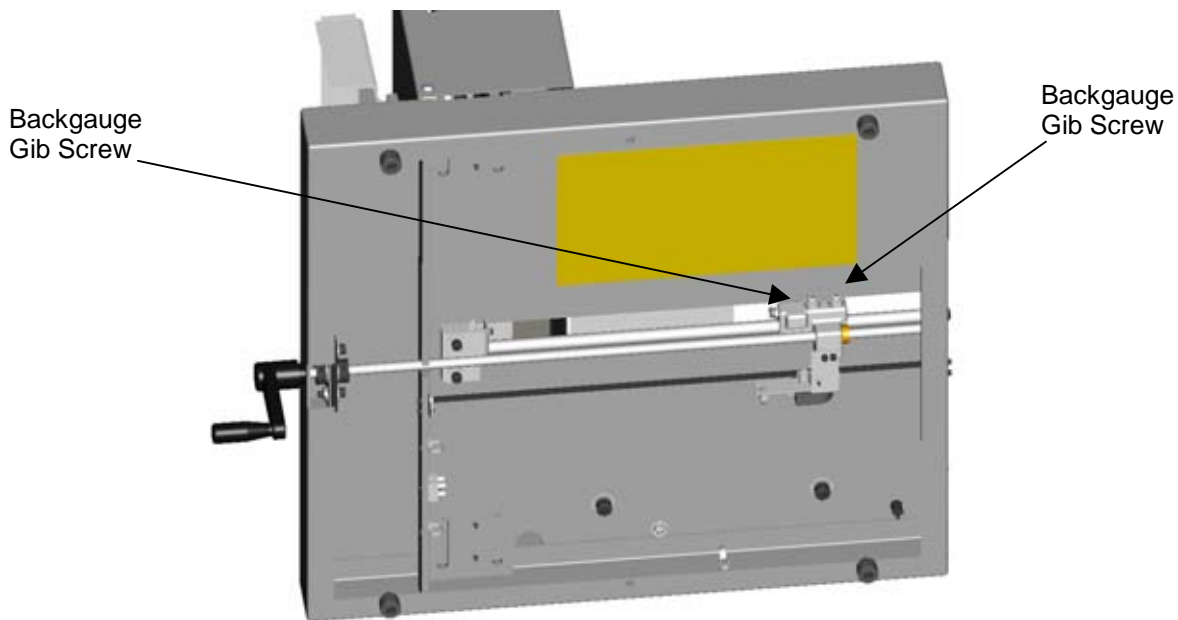

Figure 14

4. Tighten the two nylon set screws until they are just snug. They should be tight enough that the hand crank will not moved when released from any position. Do not over-tighten the screws. Lock in position with jam nuts.
5. Run the backgauge back and forth the length of the table and check for any binding. Readjust if necessary. Lay the machine flat and reattach to the stand (if applicable).

3.4.6 Leadscrew Collars

Any play in the backgauge leadscrew should not cause inaccuracies in cutting. However, excessive play can be eliminated by adjusting the leadscrew collars as follows:

1. Disconnect the power cord.
2. Place the machine on a flat level surface on it's left side.
3. Loosen the two screws attached to each collar (Figure 15).

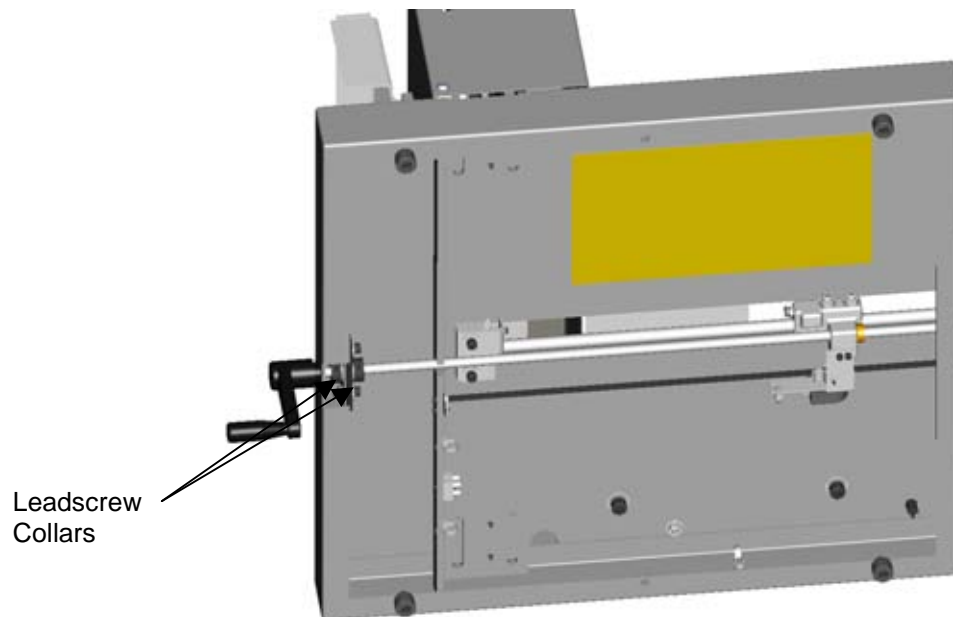

Figure 15

4. Make sure there is a slight gap between the front hand crank and the machine, slide collars up tight against the nylon washers and tighten the collar screws.
5. Check to make sure the hand crank turns freely with no play.
6. Lay the machine flat.

3.4.7 Line-Light Adjustment

The line-light can be adjusted if necessary as follows:

1. Lower the clamp to the table. Remove the clamp handle, cutting lever handle, and top cover.
2. Loosen the three line-light mounting screws (Figure 16, page 17).

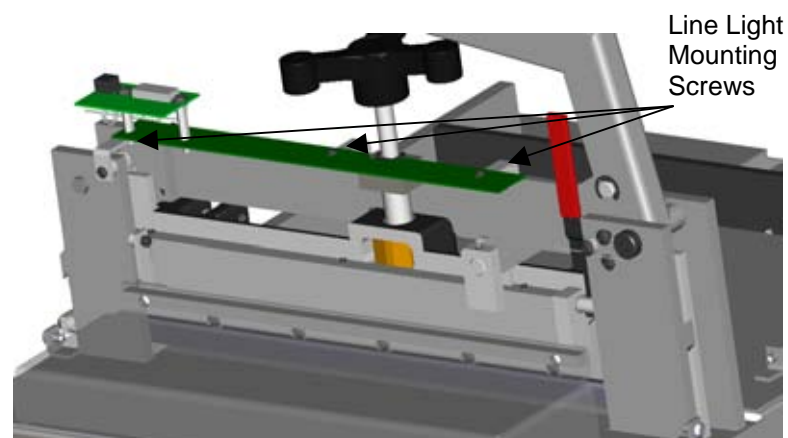

Figure 16

3. Place a white sheet of paper over the cut stick connect the power to activate the line-light.
Note: 9V is being supplied to line light board while power is on.
4. Slide the line light assembly forward or backward to get a single, crisp line.
5. Tighten the screws and disconnect power. Reinstall the clamp handle, cutting lever handle, and top cover.

3.4.8 Backgauge Encoder/Belt Adjustment

The backgauge encoder system reads the position of the backgauge and sends the information to the display. The encoder uses a belt and pulley system to read the actual position of the backgauge. The following checks and adjustments may be necessary to ensure the backgauge display reads accurately:

1. Disconnect the power.
2. Place machine on a flat level surface on it's left side.
3. Inspect the encoder bracket and mounting screws (Figure 17). Make sure the bracket is not bent, and that the screws are tight.

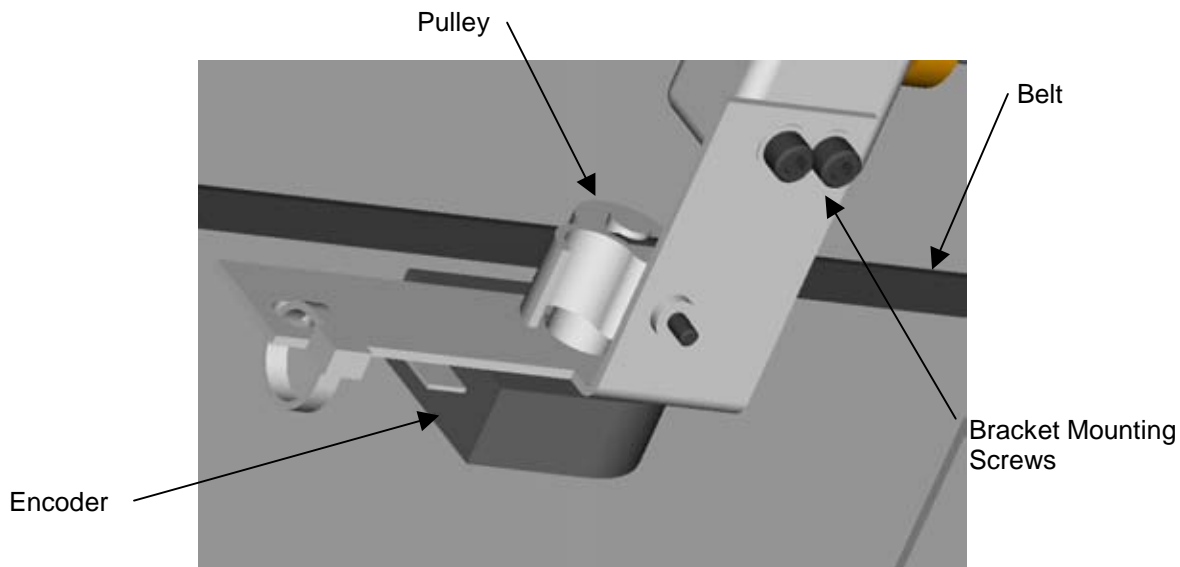

Figure 17

4. Inspect the belt and make sure it is tight but not overstretched. If it is not, loosen the (2) screws at the rear of the machine, pull belt tight, and tighten the screws. Do not stretch the belt
5. Make sure the pulley is properly lined up with the belt (Figure 17). If not, the position of the pulley can be adjusted by loosening the pulley set screw, slide the pulley into place, and tighten the setscrew.
6. Now move the backgauge forward and backward through its full range of motion, checking to make sure the pulley tracks along belt properly.
7. Lay the machine flat.

3.5 Hood and Knife Latch Adjustments

The hood and knife latch work together as the primary safety feature of this machine. They should be checked for proper operation every time the machine is serviced.

1. Lower the clamp to the table. Remove the clamp handle, cutting lever handle, and top cover.
2. Raise the hood. The hood should remain in the UP position when released. If it does not, tighten the screws that mount the hood to the machine base (Figure 18).

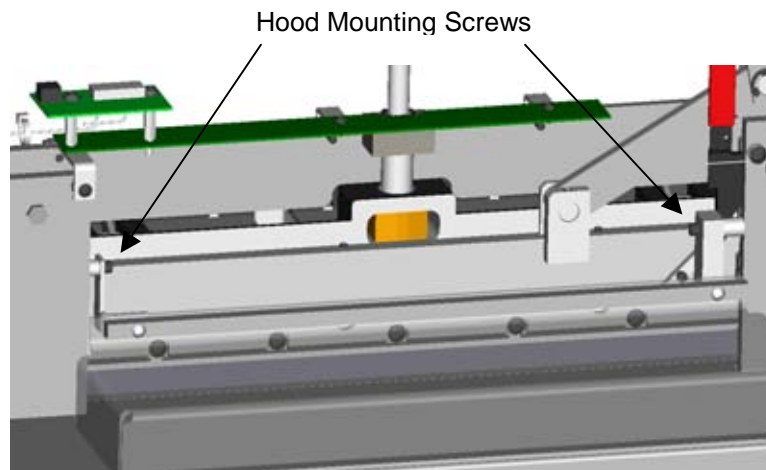

Figure 18

3. When the knife is in its furthest up position, the knife latch should be engaged with the knife keeper. The knife should not be able to be lowered unless the knife latch is moved to the right. If it can be lowered without moving the latch, the latch, keeper, and torsion spring must be replaced. The replacement procedure follows in section 3.5.1 Knife Latch Replacement on page 20.

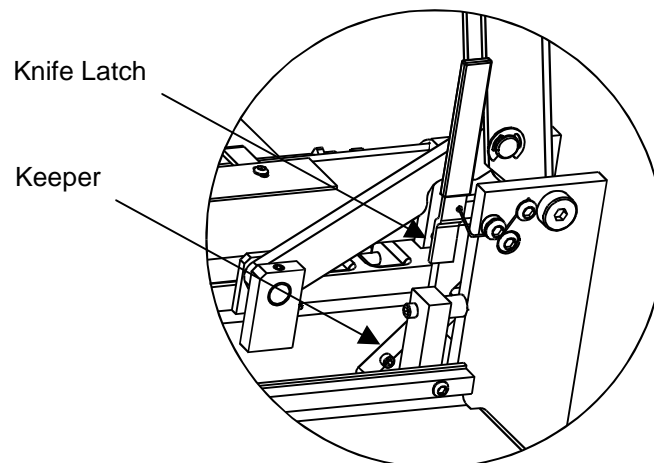

Figure 19

4. Check for secure hardware on the latch and keeper. Reinstall the clamp handle, cutting lever handle, and top cover.

3.5.1 Knife Latch Replacement

1. Use kit number **K-61074** as shown on page 41. Lower the clamp to the table. Remove the clamp handle, cutting lever handle, and top cover.
2. Remove the knife latch, knife latch spring, and hood. The hood must be removed at the machine frame, not at the hood mounting brackets.

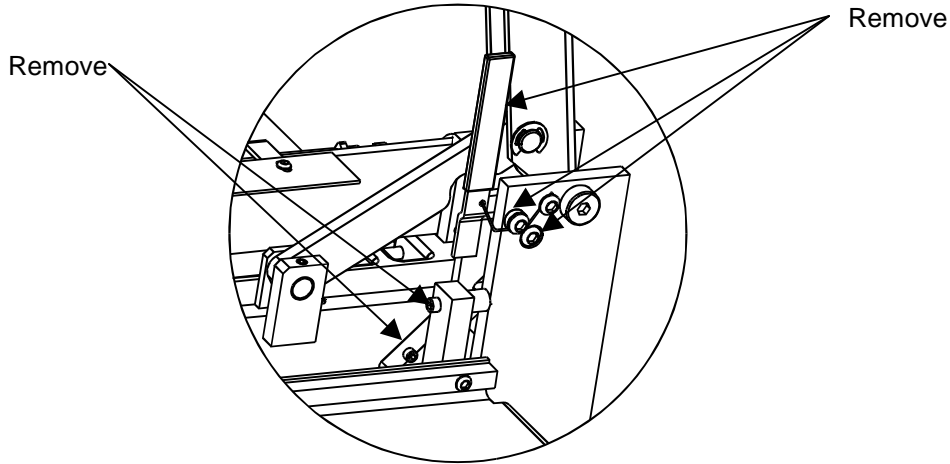

Figure 20

3. Remove the old knife bar keeper.
4. Install the new keeper using semi-permanent thread locking compound on the screws.
5. Reinstall hood. Adjust according to instructions in section 3.5 Hood and Knife Latch Adjustments on page 19.
6. Install new knife latch (apply semi-permanent thread lock to threads of mounting screw) and knife latch spring. The knife latch mounting screw should be tightened enough to take the slop out of the latch but not tight enough to inhibit free movement of the latch. One leg of the spring must be bent with pliers to engage the hole in the knife latch. Bend the left tang 90° toward the knife latch about 1/2" from the end, as shown on page 41. The other tang must be bent around its retainer screw as shown in Figure 20 above.
7. Check proper operation of the hood and knife latch. Readjust as necessary.
8. Reinstall the clamp handle, cutting lever handle, and top cover.

3.6 Troubleshooting

Problem	Possible Cause	Solution
1. The machine will not power up – no display, no line-light.	a) Power cord is disconnected. b) Disconnected wires inside machine. c) No power at electrical outlet.	a) Plug in cord. b) Check for wires that are disconnected from circuit boards, power cord, etc. c) Check outlet. Repair or use another outlet.
2. Power is on, but backgauge display is blank.	a) Disconnected wires inside machine. b) Faulty display circuit board. c) Backgauge in Preset Position on power-up.	a) Check for wires that are disconnected from circuit boards, etc. b) Replace display circuit board. c) Move backgauge toward rear and reconnect power to mach.
3. Backgauge display shows: "----".	a) Backgauge has not been preset.	a) Preset Backgauge by bringing backgauge to front of machine (see Operator's Manual for more info).
4. Power is on, but line light does not light up.	a) Disconnected wires inside machine. b) Faulty line light circuit board.	a) Check for wires that are disconnected from line-light circuit board, etc. b) Replace line light circuit board.
5. Backgauge display is inaccurate.	a) Backgauge accuracy needs adjustment. b) Encoder malfunction. c) Faulty display circuit board.	a) See Section 3.4.2 Backgauge Accuracy Adjustment, page 12. b) Check encoder system (see Section 3.4.8 Backgauge Encoder/Belt Adjustment, page 18) or replace encoder. c) Replace display circuit board.
6. Knife cuts deeper on one side than the other.	a) Knife is not seated all the way up in knife bar. b) Knife level is not set properly	a) Loosen knife screws and use knife lifter assembly to raise knife up tight. b) See Section 3.4.4 Knife Leveling Adjustment, page 14.
7. The operator strains through a cut.	a) Dull knife. b) Paper clamped too tight.	a) Change the knife with a new or sharpened one. See Operator's Manual for knife changing information and instructions. b) Apply less force on clamp handle when clamping paper.
8. Concave cutting – ends wide, center narrow.	a) Excessive moisture at edges of paper.	a) Keep paper in dry location.
9. Concave cutting – variation from top to bottom.	a) Soft paper not firmly clamped. b) Knife dull or incorrectly ground.	a) Apply more force on clamp handle when clamping. b) Change the knife with a new or sharpened one. See Operator's Manual for knife changing information and instructions.

4.0 Parts Lists

4.1 Main Assembly – Backgauge Bracket

61000 Sht. 1

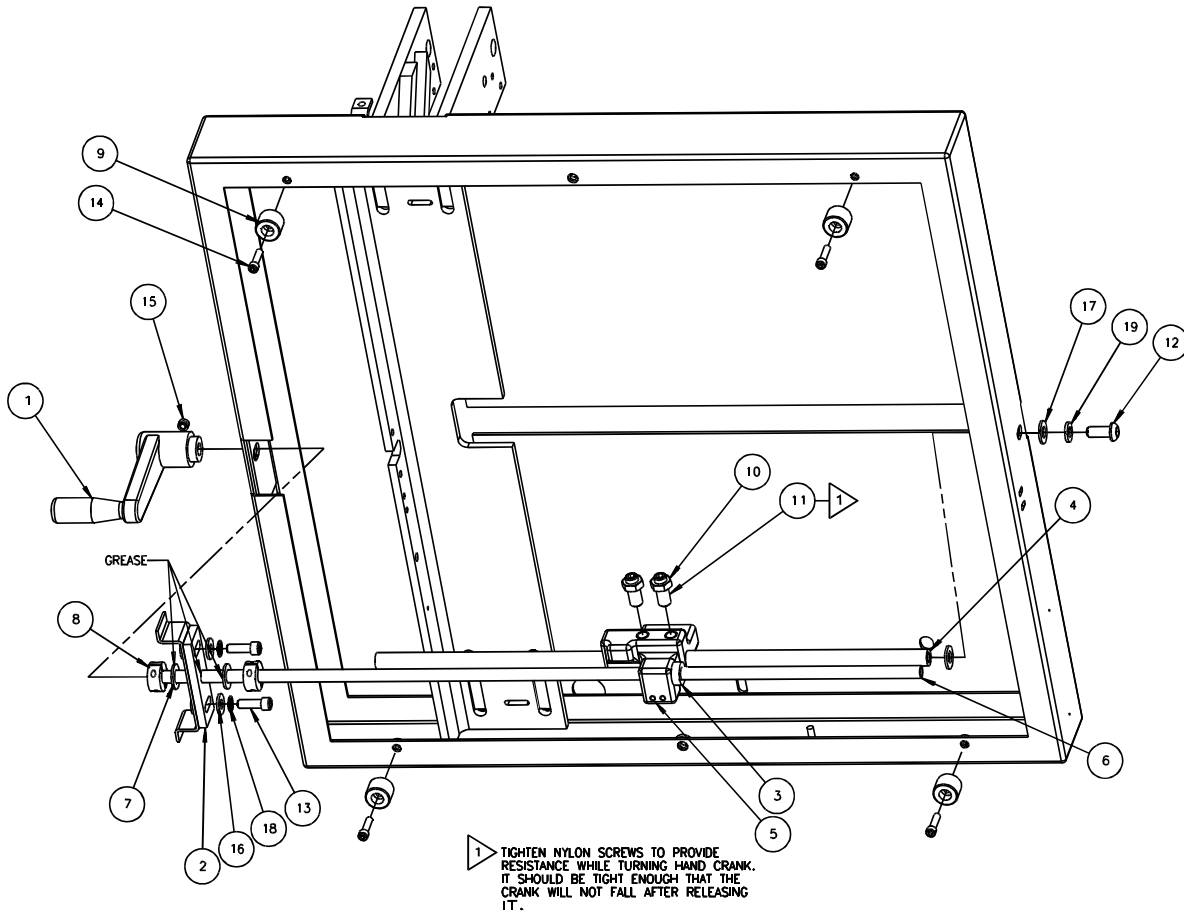

Main Assembly – Backgauge Bracket

61000 Sht. 1

Item	Part No.	Description	Qty.
1	60043	HANDCRANK - BACKGAUGE	1
2	60115	ADJUSTABLE PILLOW BLOCK	1
3	60213	LEADSCREW NUT	1
4	61044	GUIDE SHAFT	1
5	61045	BACKGAUGE NUT- MACHINED	1
6	61047	LEADSCREW	1
7	11288-5	NYLON WASHER	2
8	A-10081-4	SPLIT COLLAR	2
9	A-11074	FOOT - RUBBER	4
10	H-6424-6	NUT - 3/8-16 HEX JAM	2
11	H-6890-608	SCREW - 3/8-16 X 1 NYLON SOC SET	2
12	H-6910-506	SCREW - 5/16-18 X 3/4 BUTTON HEAD CAP	1
13	H-6918-406	SCREW - 1/4-20 X 3/4 SOCKET HEAD CAP	2
14	H-6918-102406	SCREW - #10-24 X 3/4 SOCKET HEAD CAP	4
15	H-6940-102403	SCREW - #10-24 X 3/16 FLAT SOC SET	1
16	H-7321-4	WASHER - 1/4 SAE PLAIN	2
17	H-7321-5	WASHER - 5/16 SAE PLAIN	2
18	H-7324-8	WASHER - 1/4 INT TOOTH	2
19	H-7327-10	WASHER - 5/16 MEDIUM LOCK	1

4.2 Main Assembly – Clamp

61000 Sht. 2

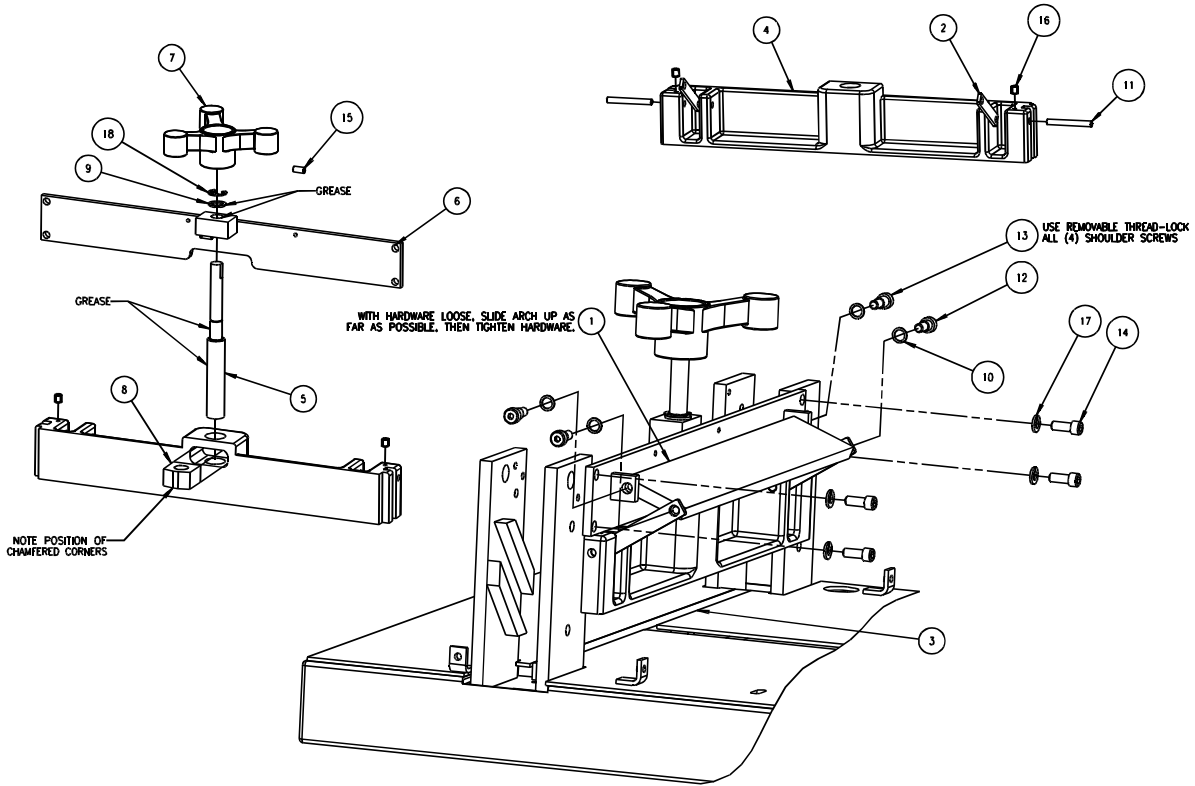

Main Assembly – Clamp

61000 Sht. 2

Item	Part No.	Description	Qty.
1	60017	TORSION BAR	1
2	60018	TORSION LINK	2
3	60057	CUT STICK	1
4	61025	CLAMP	1
5	61026	CLAMP LEADSCREW	1
6	61027	ARCH WELDMENT	1
7	61033	THREE-ARM HANDLE- MACHINED	1
8	61066	CLAMP NUT	1
9	20075-10	SHIM	1
10	61065-313032	SHLD SCR SHORTENING SHIM- 5/16	4
11	H-5246-416	DOWEL PIN - 1/4 X 2 HD GD	2
12	H-5254-502	SCREW - 5/16 X 1/4 SHSS	2
13	H-5254-503	SCREW - 5/16 X 3/8 SHSS	2
14	H-6918-405	SCREW - 1/4-20 X 5/8 SOCKET HEAD CAP	4
15	H-6938-408	SCREW - 1/4-20 X 1/2 CUP SOC SET	1
16	H-6938-102405	SCREW - #10-24 X 5/16 CUP SOC SET	2
17	H-7327-8	WASHER - 1/4 MEDIUM LOCK	4
18	S-1193-50	E-RING - 1/2"	1

4.3 Main Assembly – Knife Drive

61000 Sht. 3

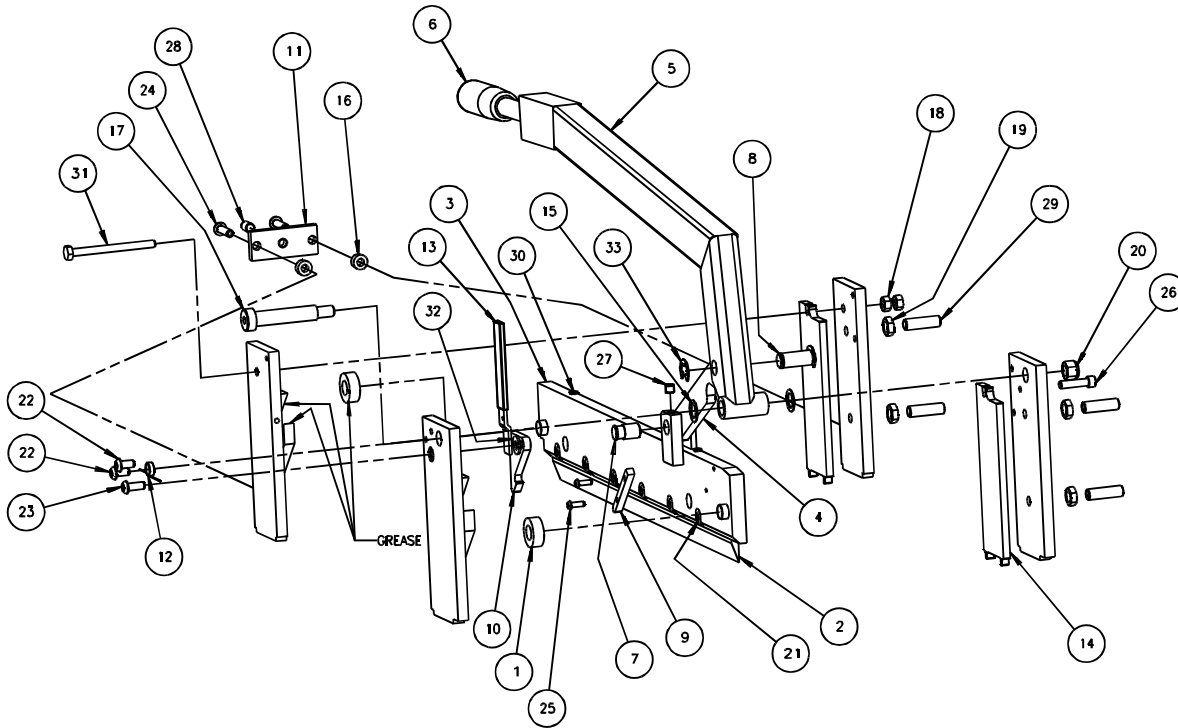

BEND LEFT TANG 90° TOWARD KNIFE LATCH AT 3/4 INCH.
HOOK BENT TANG INTO HOLE IN KNIFE LATCH HANDLE.
WRAP OTHER TANG ONTO THE OTHER BUTION HEAD SCREW.

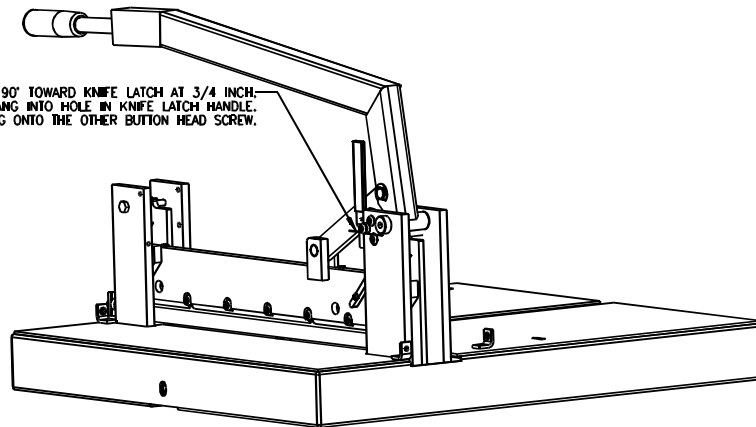

Main Assembly – Knife Drive

61000 Sht. 3

Item	Part No.	Description	Qty.
1	60003	ROLLER	2
2	60011-2	KNIFE	1
3	61015	KNIFE BAR WELDMENT	1
4	61020	KNIFE BAR LINK	1
5	61021	LEVER ARM WELDMENT	1
6	61036	LEVER ARM HANDLE	1
7	61037	KNIFE LINK PIN	1
8	61038	KNIFE LINK PIN	1
9	61039	KNIFE BAR KEEPER	1
10	61042	KNIFE LATCH	1
11	61064	SETSCREW BLOCK	1
12	61071	TORSION SPRING	1
13	61072	KNIFE LATCH CAP	1
14	61018-1	GIB	2
15	61065-500032	SHLD SCR SHORTENING SHIM- 1/2	2
16	E-1152-93	STANDOFF	2
17	H-5254-818	SCREW - 1/2 X 2-1/4 SHSS	1
18	H-6417-4	NUT - 1/4-20 HEX	2
19	H-6424-6	NUT - 3/8-16 HEX JAM	4
20	H-6442-6	NUT - 3/8-16 NYLOC	1
21	H-6910-403	SCREW - 1/4-20 X 3/8 BUTTON HEAD CAP	6
22	H-6910-404	SCREW - 1/4-20 X 1/2 BUTTON HEAD CAP	2
23	H-6910-405	SCREW - 1/4-20 X 5/8 BUTTON HEAD CAP	1
24	H-6910-408	SCREW - 1/4-20 X 1 BUTTON HEAD CAP	2
25	H-6910-83204	SCREW - #8-32 X 1/2 BUTTON HEAD CAP	2
26	H-6918-408	SCREW - 1/4-20 X 1 SOCKET HEAD CAP	1
27	H-6940-404	SCREW - 1/4-20 X 1/4 FLAT SOC SET	1
28	H-6940-508	SCREW - 5/16-18 X 1/2 FLAT SOC SET	1
29	H-6940-620	SCREW - 3/8-16 X 1-1/4 FLAT SOC SET	4
30	H-6940-102428	SCREW - #10-24 X 1-3/4 FLAT SOC SET	2
31	H-6992-424	SCREW - 1/4-20 X 3 FULL THD HEX HD	1
32	H-7321-4	WASHER - 1/4 SAE PLAIN	1
33	S-1193-50	E-RING - 1/2"	2
34	SU-30-106	GREASE - DAMPENING	1

4.4 Main Assembly – Backgauge

61000 Sht. 4

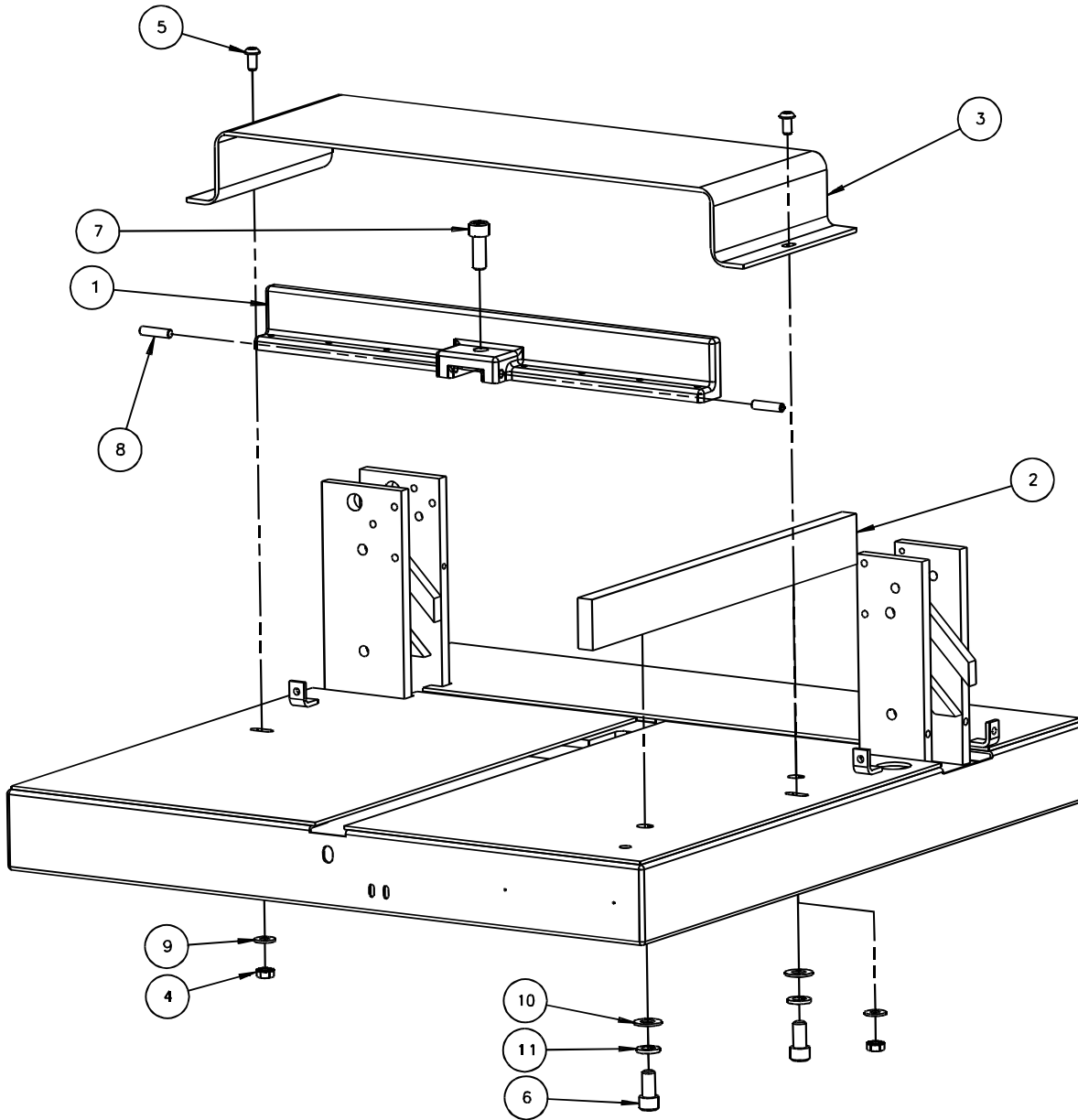

Main Assembly – Backgauge

61000 Sht. 4

Item	Part No.	Description	Qty.
1	60203	BACKGAUGE ASSEMBLY	1
2	61057	SIDE GUIDE	1
3	61059	REAR COVER	1
4	H-6423-4	NUT - 1/4-20 HEX KEP	2
5	H-6910-404SS	SCREW - 1/4-20 X 1/2 BUT. HEAD CAP STAINLESS	2
6	H-6918-606	SCREW - 3/8-16 X 3/4 SOCKET HEAD CAP	2
7	H-6918-608	SCREW - 3/8-16 X 1 SOCKET HEAD CAP	1
8	H-6938-416	SCREW - 1/4-20 X 1 CUP SOC SET	2
9	H-7321-4	WASHER - 1/4 SAE PLAIN	2
10	H-7321-6	WASHER - 3/8 SAE PLAIN	2
11	H-7327-12	WASHER - 3/8 MEDIUM LOCK	2

4.5 Main Assembly – Top Cover

61000 Sht. 5

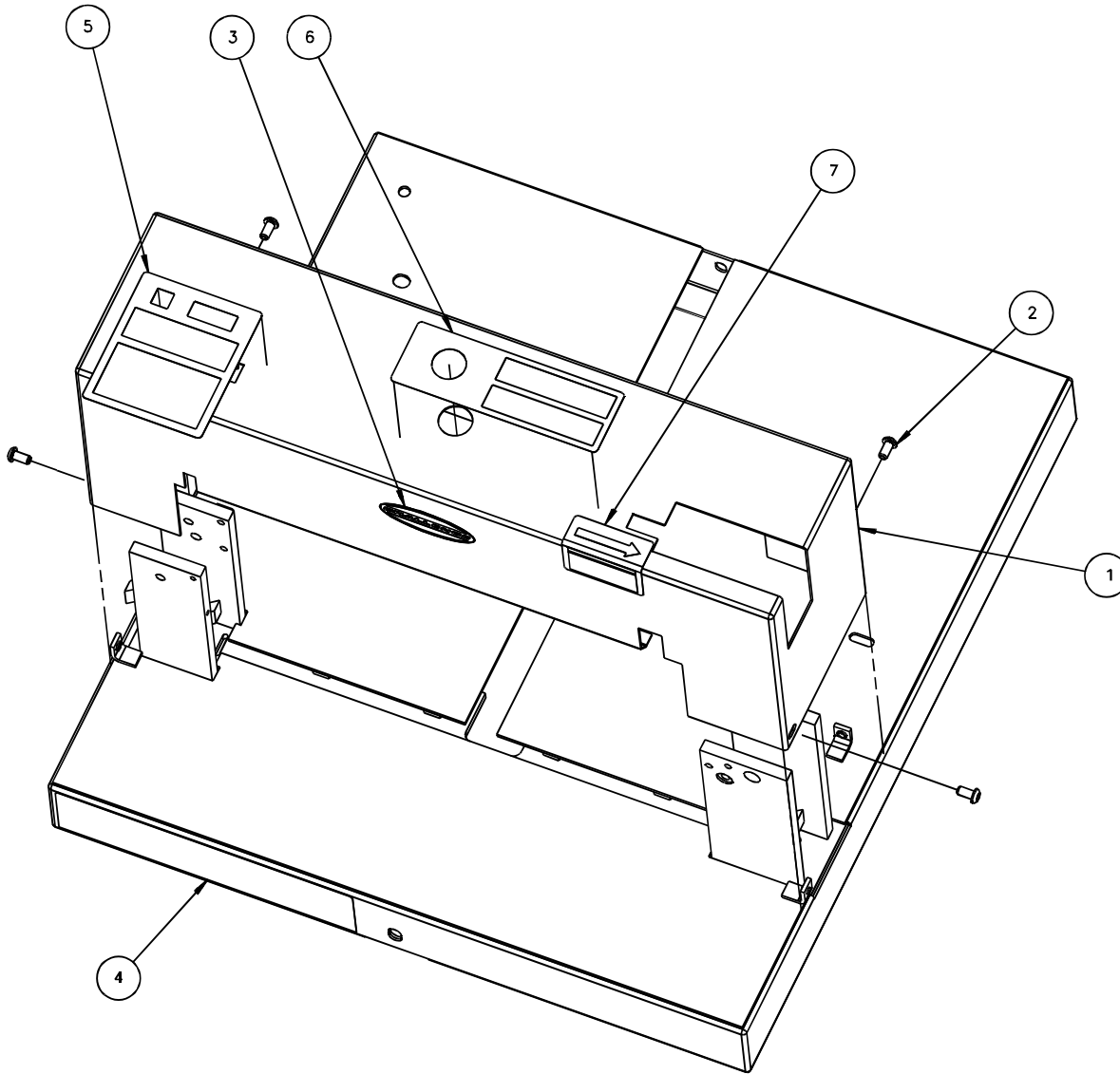

Item	Part No.	Description	Qty.
1	61049	ARCH COVER	1
2	H-6910-404SS	SCREW - 1/4-20 X 1/2 BUT. HEAD CAP STAINLESS	4
3	S-1076-2	CHALLENGE LABEL	1
4	S-1781-119	LABEL- FRONT PANEL	1
5	S-1781-126	LABEL- DIGITAL DISPLAY	1
6	S-1781-131	LABEL - TOP COVER	1
7	S-1781-136	LABEL- DO NOT ALTER SAFETY DEVICES	1

4.6 Main Assembly – Hood

61000 Sht. 6

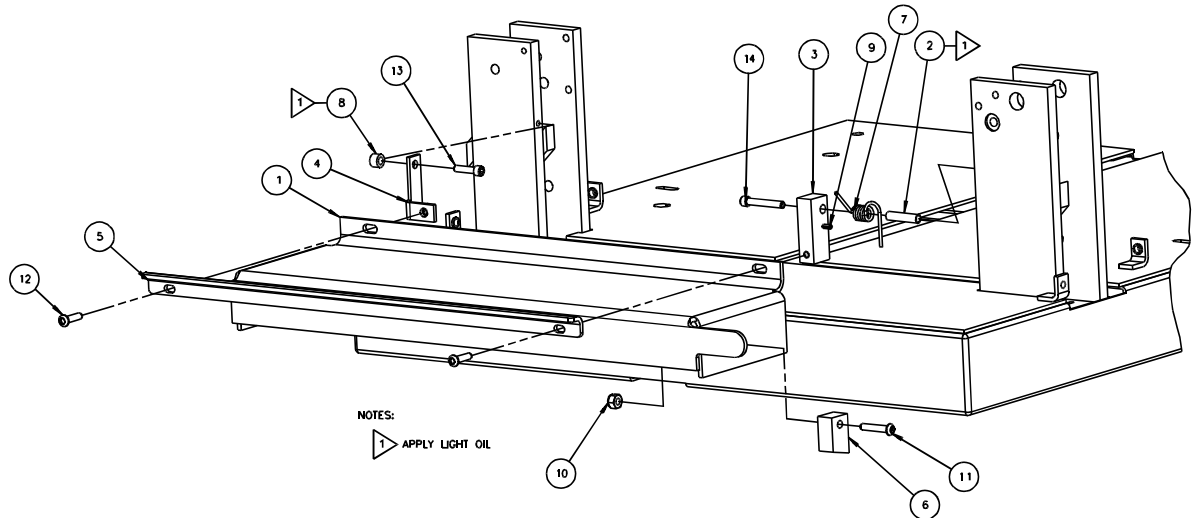

Item	Part No.	Description	Qty.
1	61052	HOOD	1
2	61054	BUSHING	1
3	61055	HINGE BLOCK	1
4	61056	HINGE BRACKET	1
5	61060	TILT SHIELD STIFFENER	1
6	61074	MAGNET BLOCK ASSEMBLY	1
7	61075	TORSION SPRING	1
8	E-1152-99	STANDOFF	1
9	H-21S-125-0500	ROLL PIN - 1/8 X 1/2	1
10	H-6442-#10	NUT - #10-24 NYLOC	1
11	H-6910-102408	SCREW - #10-24 X 1 BUTTON HEAD CAP	1
12	H-6910-102406SS	SCREW - #10-24 X 3/4 BUT. HEAD CAP STAINLESS	2
13	H-6918-102406	SCREW - #10-24 X 3/4 SOCKET HEAD CAP	1
14	H-6918-102410	SCREW - #10-24 X 1-1/4 SOCKET HEAD CAP	1

4.7 Main Assembly – Electrical

61000 Sht. 7

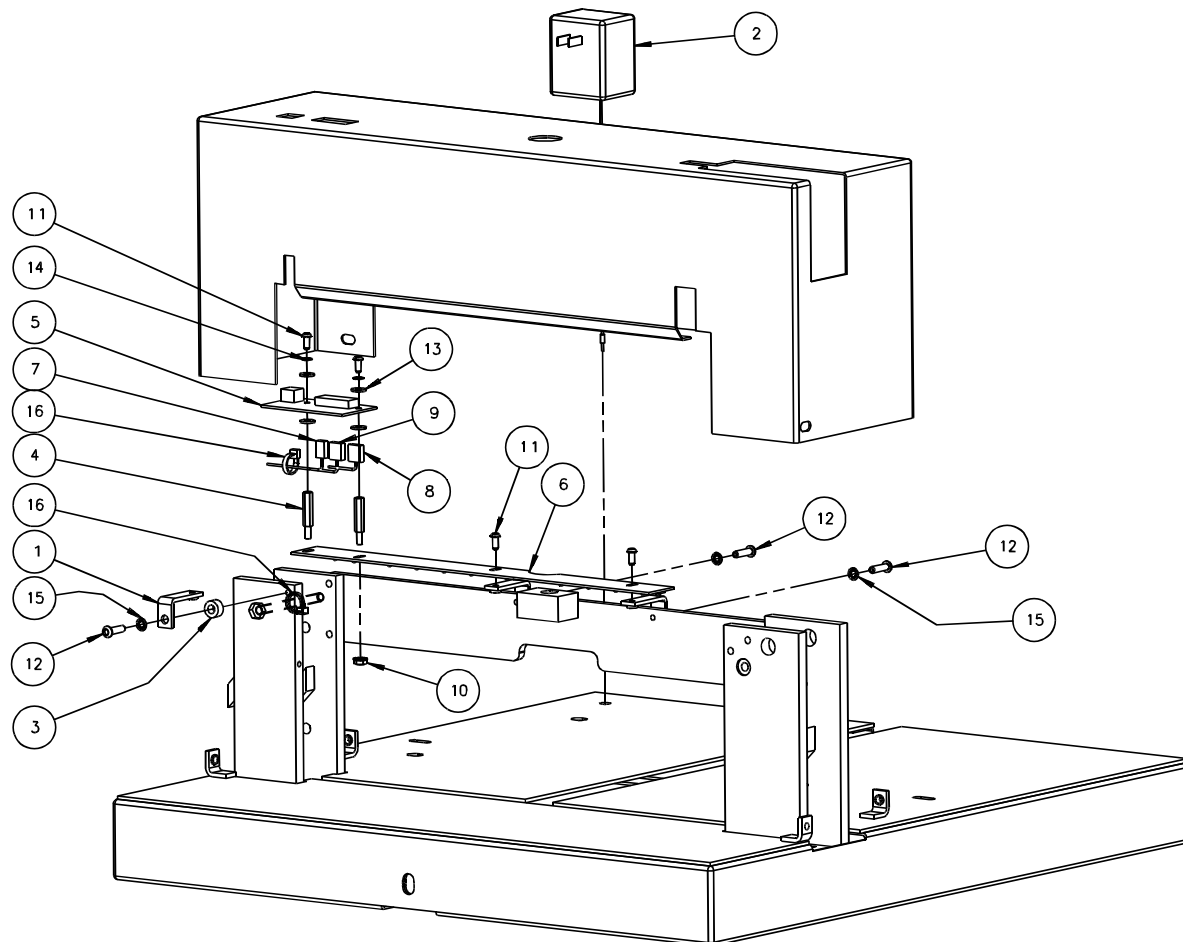

Main Assembly – Electrical

61000 Sht. 7

Item	Part No.	Description	Qty.
1	60040	LINE LIGHT BRACKET	3
2	E-3078	TRANSFORMER- WALL, 120V TO 9VDC	1
3	E-1152-93	STANDOFF	1
4	E-1152-102	STANDOFF	2
5	EE-3065	PCB SMT ASM- COUNTER	1
6	EE-3126	BOARD	1
7	EE-3131	WIRE ASSEMBLY- DISPLAY	1
8	EE-2899-2	ENCODER CABLE ASSEMBLY	1
9	EE-3131-1	PRESET CABLE ASSEMBLY	1
10	H-6423-N8	NUT - #8-32 HEX KEP	1
11	H-6910-83203	SCREW - #8-32 X 3/8 BUTTON HEAD CAP	4
12	H-6910-102406	SCREW - #10-24 X 3/4 BUTTON HEAD CAP	3
13	H-7320-#8	WASHER - #8 FIBER	4
14	H-7324-#8	WASHER - #8 INT TOOTH	2
15	H-7324-#10	WASHER - #10 INT TOOTH	3
16	S-1694	TYRAP	2

4.8 Main Assembly – Encoder Mount

61000 Sht. 8

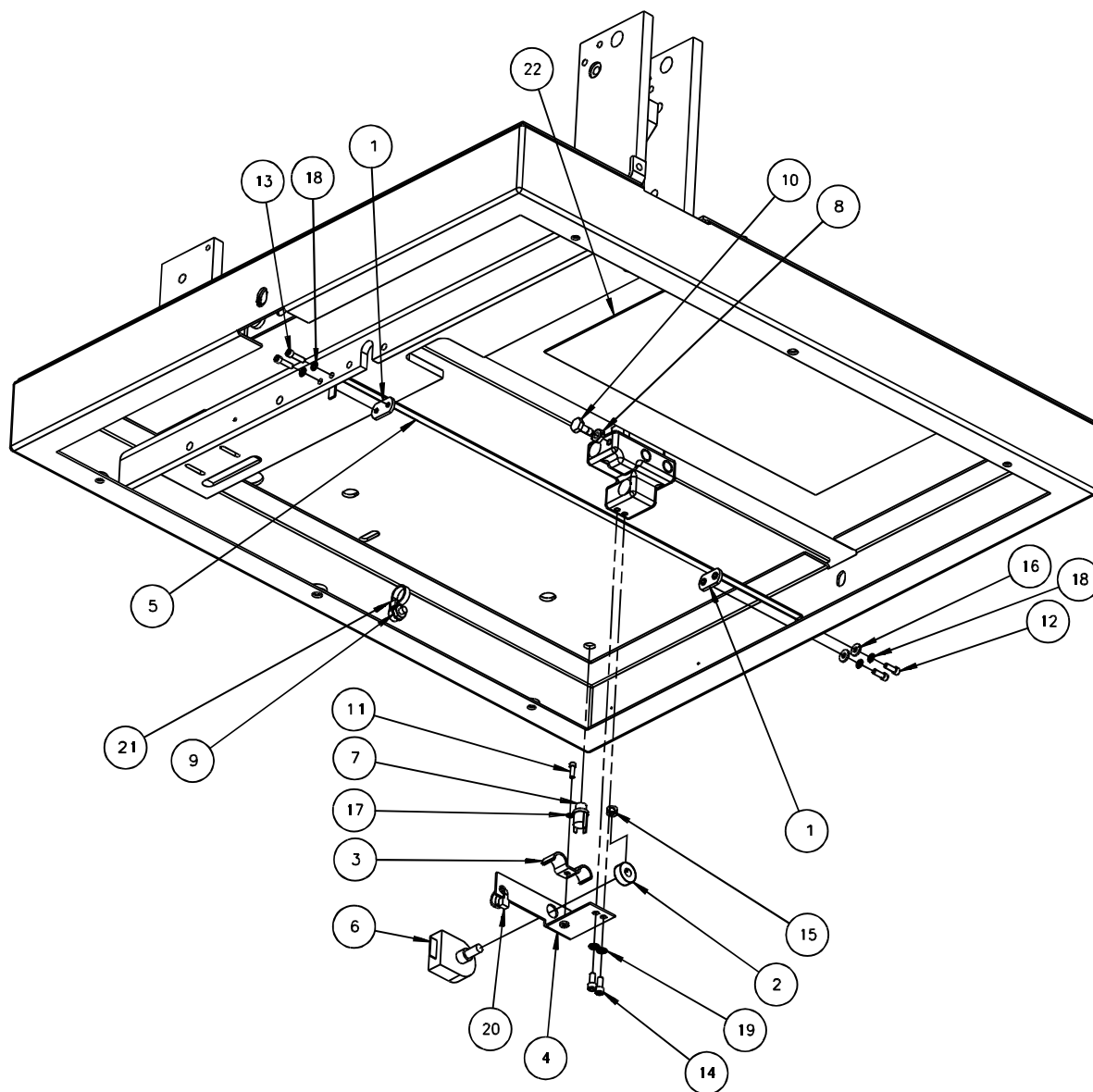

Main Assembly – Encoder Mount

61000 Sht. 8

Item	Part No.	Description	Qty.
1	60042	DOUBLE NUT- #6-32	2
2	60208	TIMING PULLEY- 25 GROOVE MXL	1
3	60212	CABLE CLAMP	1
4	61062	ENCODER BRACKET	1
5	61063	BELT	1
6	E-2467-2	ENCODER	1
7	EE-3077	POWER JACK- DC	1
8	H-6417-N10	NUT - #10-24 HEX	1
9	H-6423-N10	NUT - #10-24 HEX KEP	1
10	H-6913-102404	SCREW - #10-24 X 1/2 HEX HEAD CAP	1
11	H-6918-44003	SCREW - #4-40 X 3/8 SOCKET HEAD CAP	1
12	H-6918-63203	SCREW - #6-32 X 3/8 SOCKET HEAD CAP	2
13	H-6918-63204	SCREW - #6-32 X 1/2 SOCKET HEAD CAP	2
14	H-6918-83203	SCREW - #8-32 X 3/8 SOCKET HEAD CAP	2
15	H-6940-63203	SCREW - #6-32 X 3/16 FLAT SOC SET	1
16	H-7321-#6	WASHER - #6 SAE PLAIN	2
17	H-7324-#4	WASHER - #4 INT TOOTH	1
18	H-7324-#6	WASHER - #6 INT TOOTH	4
19	H-7324-#8	WASHER - #8 INT TOOTH	2
20	S-1694	TYRAP	1
21	S-1694-2	TYRAP - #10	1
22	S-1781-134	LABEL- INTERCONNECTION	1

4.9 Main Assembly – Preset

61000 Sht. 9

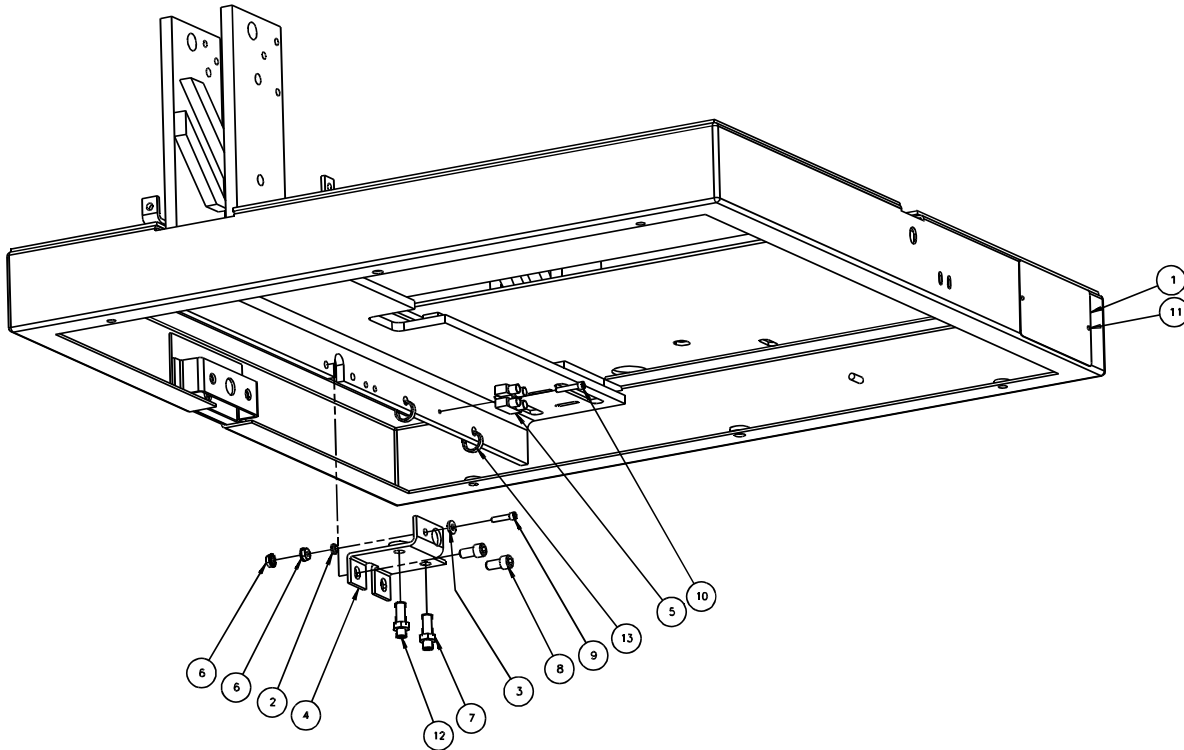

Item	Part No.	Description	Qty.
1	14050	SERIAL PLATE	1
2	47214	WASHER- SHOULDER, NYLON	1
3	11288-7	NYLON WASHER	1
4	61043-1	SHAFT MOUNTING BRACKET	1
5	E-2626-2	TERMINAL STRIP (2P)	1
6	H-6423-#6	NUT - #6-32 HEX KEP	2
7	H-6424-4	NUT - 1/4-20 HEX JAM	2
8	H-6918-404	SCREW - 1/4-20 X 1/2 SOCKET HEAD CAP	2
9	H-6918-63205	SCREW - #6-32 X 5/8 SOCKET HEAD CAP	1
10	H-6918-63206	SCREW - #6-32 X 3/4 SOCKET HEAD CAP	1
11	H-6924-004	SCREW - #0 X 1/4 DRIVE SCREW	2
12	H-6940-416	SCREW - 1/4-20 X 1 FLAT SOC SET	2
13	S-1694	TYRAP	2

4.10 Backgauge Assembly

60203

NO.	PART NO.	DESCRIPTION	QTY
1	60201	BACKGUAGE-- MACHINED	1
2	60204	FLOATING FINGER	8
3	H-5246-406	DOWEL PIN - 1/4 X 3/4 HD GD	1

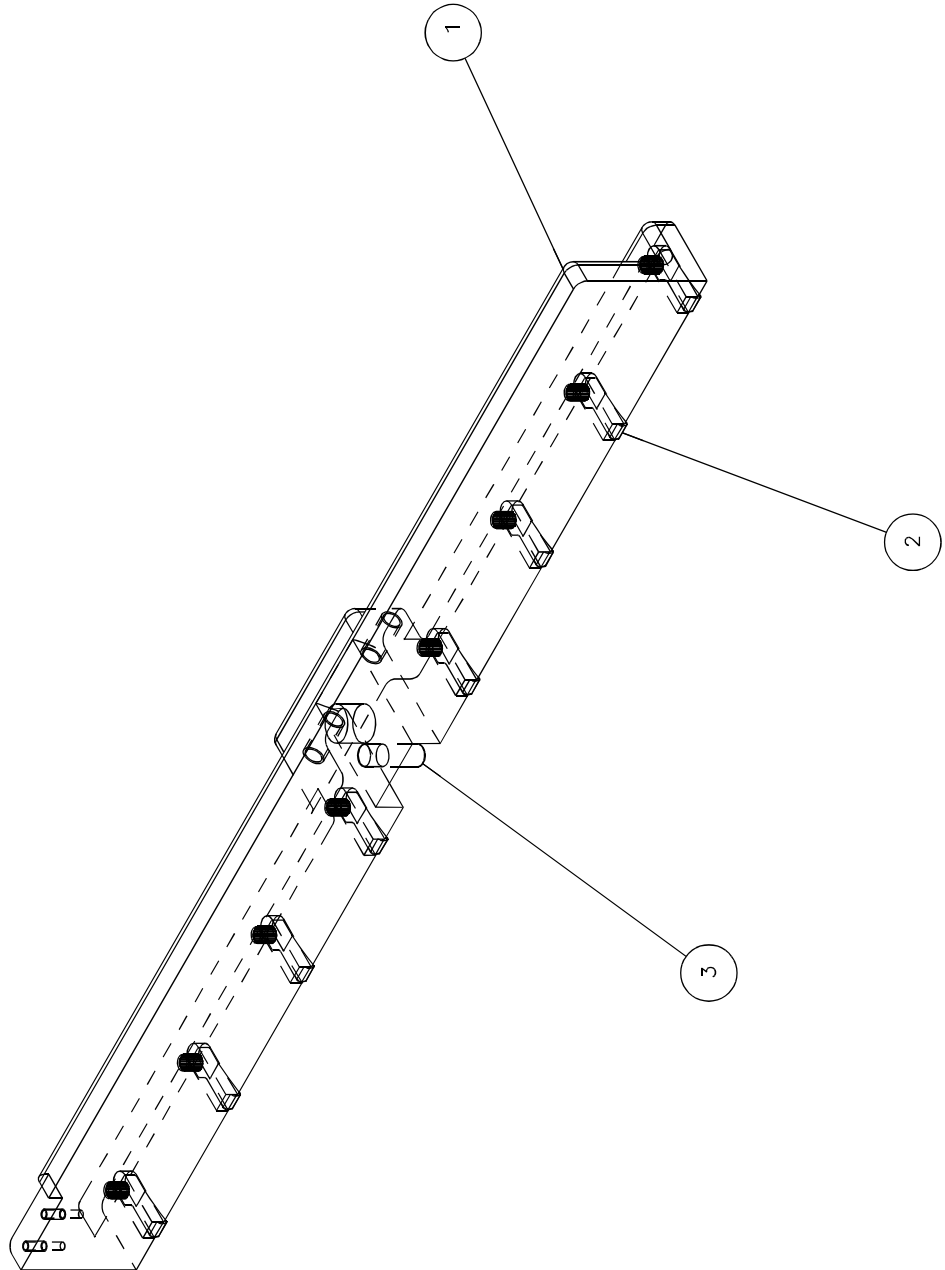

4.11 Interconnection Diagram

E-3130, Rev. A

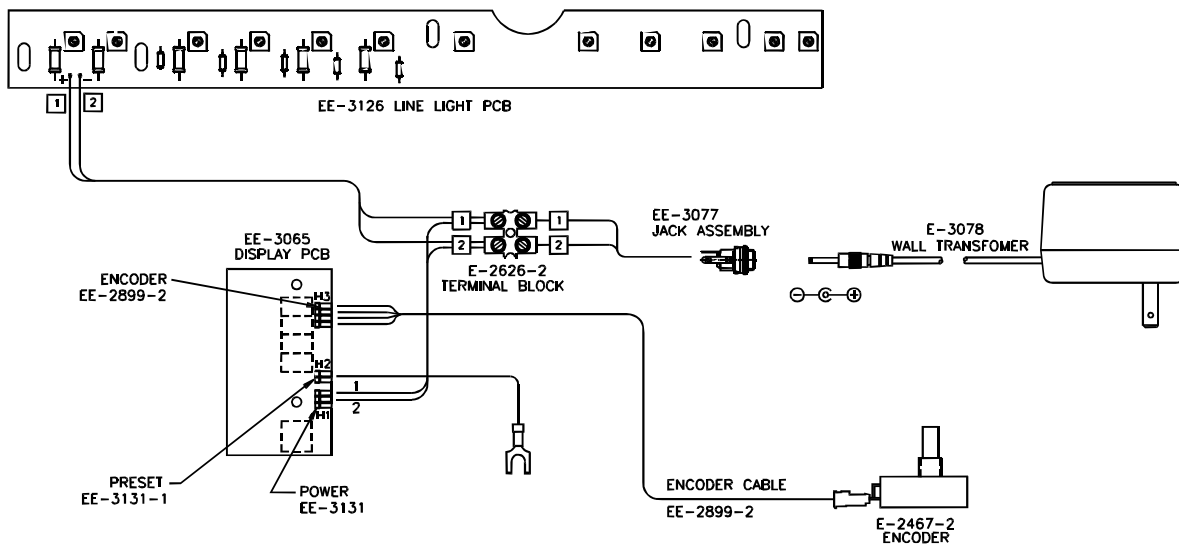

4.12 Label- Electrical

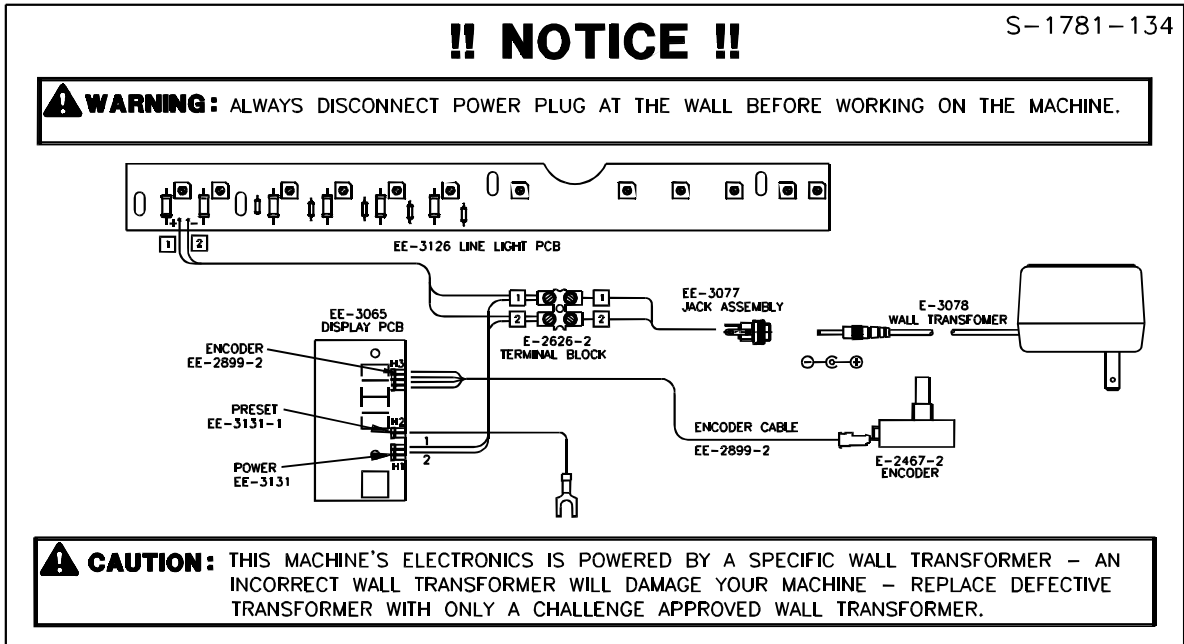

S-1781-134, Rev. A



4.13 Label – Caution

S-1781-119, Rev. A

⚠ CAUTION ⚠

 <p>DO NOT OPERATE WITH MORE THAN ONE PERSON!</p>	 <p>CUT/CRUSH HAZARD! KEEP HANDS FROM UNDER PLUNGER AND KNIFE WHILE IN OPERATION!</p>	 <p>DO NOT OPERATE WITH ANY COVERS REMOVED!</p>
---	---	---

4.14 Optional Floor Stand Assembly

61070, Rev. A

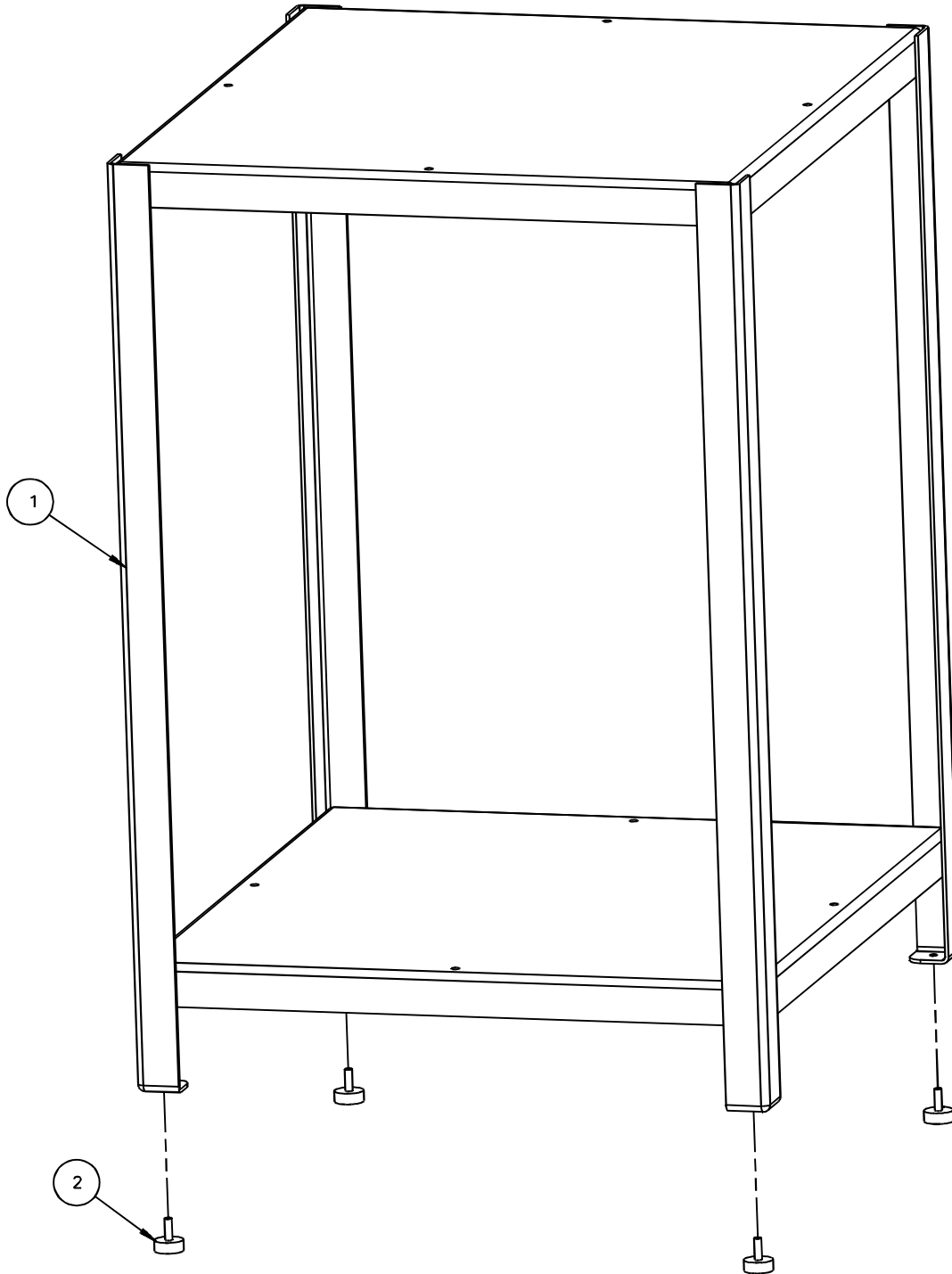

Item	Part No.	Description	Qty.
1	61067	STAND	1
2	40016-6	MOUNT - VIBRATION	4
3	H-6910-408	SCREW - 1/4-20 X 1 BUTTON HEAD CAP	2

4.15 Knife Latch Replacement Kit

K-61074, Rev. "A". See instructions in Section 3.5.1 Knife Latch Replacement on page 20.

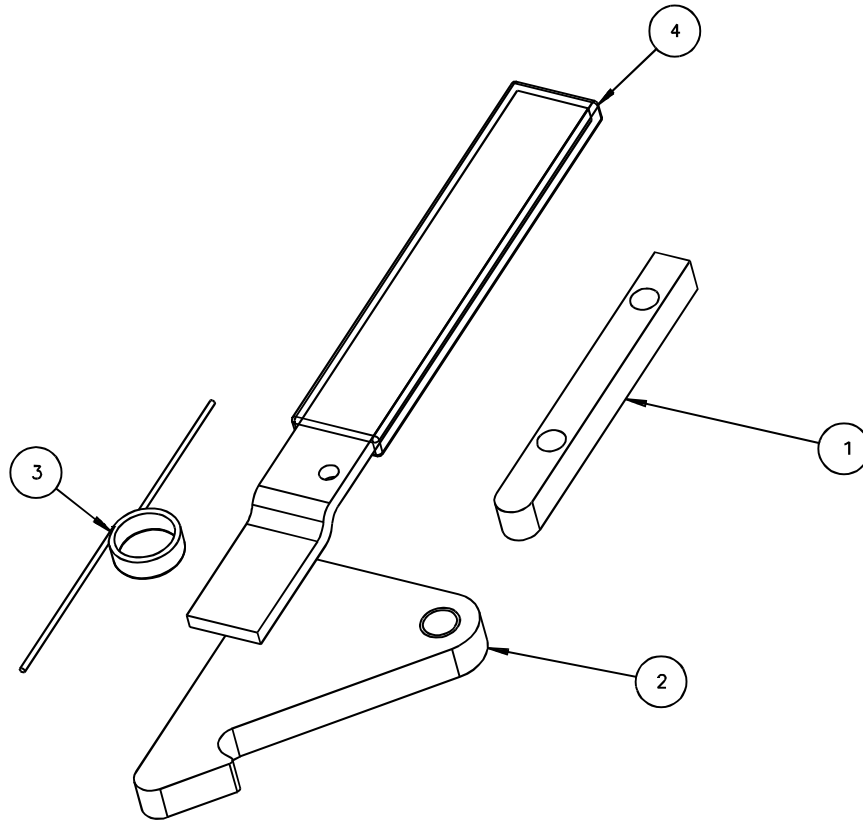

NOTES:
1. PUSH RUBBER CAP ONTO KNIFE LATCH LEVER AS SHOWN.

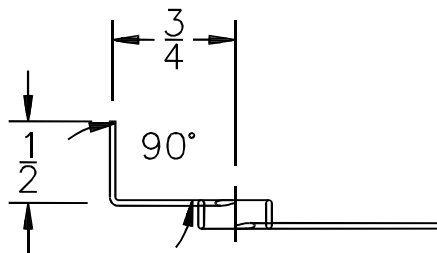
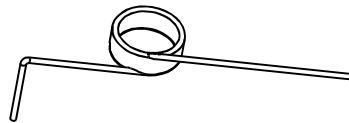

SPRING MUST BE BENT AS SHOWN

Item	Part No.	Description	Qty.
1	61039	KNIFE BAR KEEPER	1
2	61042	KNIFE LATCH	1
3	61071	TORSION SPRING	1
4	61072	KNIFE LATCH CAP	1