

GBC ORCA 64

Instruction Manual



Provided by

MyBinding.com

When Image Matters.

Call Us at 1-800-944-4573

GBC ORCA 64

OPERATION AND MAINTENANCE MANUAL

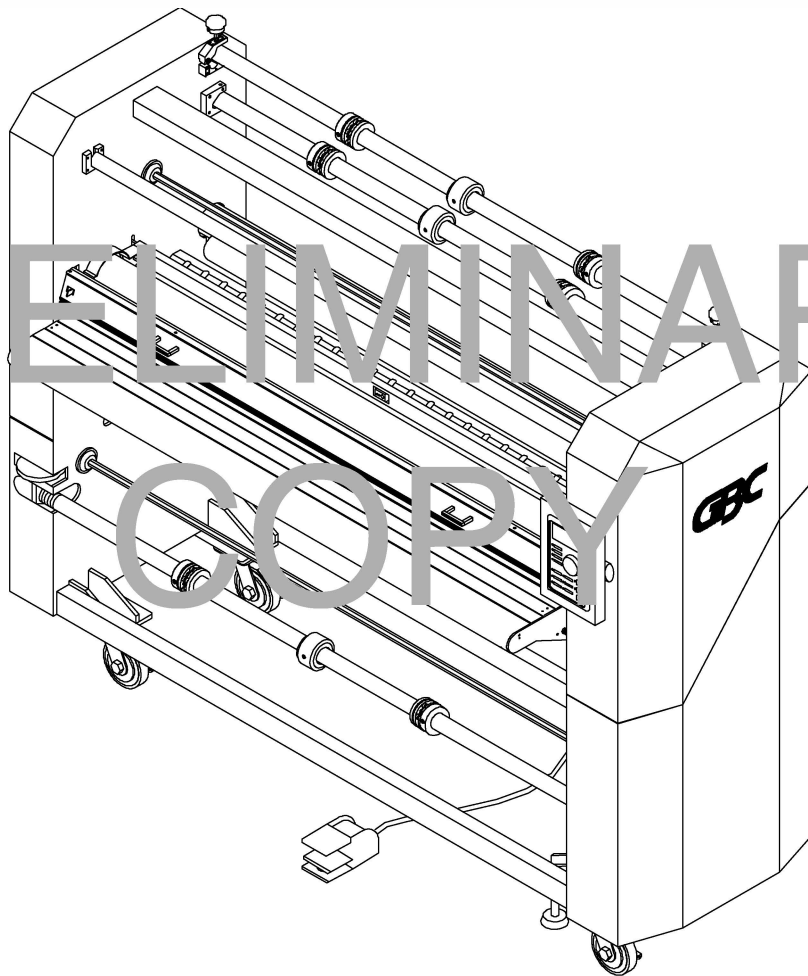

Operating Instructions

- I** Istruzioni per l'Uso
- D** Bedienungsanleitungen
- NL** Gebruiksaanwijzing
- F** Mode d'Emploi
- E** Manual de Operación

PART NUMBER: 930-095

TABLE OF CONTENT

Disclaimer	1
Important Safety Instructions	2
Important Safeguards	4
General	4
Electrical	4
Service	4
Warranty	6
Specifications	8
Pre-Installation	10
Installation	12
Features Guide	14
Power Switch	14
Control Panel	14
E-Stop	18
Safety Shield Interlock Latch	18
Safety Shield	18
Feed Table	20
Vacuum	20
Heat Rollers	20
Idler Bar	20
Pull Rollers	20
Film Shaft	20
Film Shaft Brake	20
Core Adaptors	20
Center Core Support	20
Rewind Shaft	22
Rewind Brake	22
Rewind Tube	22
Rewind Adaptors	22
Chill Idler	22
Cooling Fans	22
Clutch	22
Secondary Upper Unwind	22
Secondary Upper Unwind Brake	22
In-Line Slitters	24
Footswitch	24
Exit Idler	24
Rear Slitter	24
Separator Bar	24
Film Web	24
Nip Point	24
Operating Instructions	26
Film Loading and Threading	26
Webbing Thermal Film	28
Webbing PSA Film	30
Start Laminating	32
Tacking New Film	34
Unweb the Laminator	36
Clearing a Film Jam	36
Pre-Coating	38
Mounting Pre-Coated Boards	38
Single Sided Lamination	38
Creating a Decal	40
Mounting a Decal	40
PSA Encapsulation	40
Thermal Encapsulation	42
MicroNex	42
Speed / Temperature Guide	44

--	--	--

The Art Of Lamination	46
Basic Rules	46
Film Tension	46
Heat	48
Output	48
Maintenance	50
Caring for the Catena	50
Troubleshooting Guide	52
Service Agreement	52
Recommended Spares	58
List	58
Illustrated Parts	60
Frame Assembly	60
Rewinder Shaft Assembly	61
Rollers and Sensor Assembly	62
Front & Rear Table Assembly	63
Chain Linking Assembly	64
Main Roller Lift Assembly	65
Pull Roller Lift Assembly	66
Safety Shield Assembly	67
Control Panel Assembly	68
Power Panel Assembly	69
Heater Assembly	70
Film Guide Assembly	71
Upper & Lower Idler Assembly	72
Clutch Assembly	73
Rewinder Sprocket Assembly	74
Unwind Assembly	75
Micronex Brake Assembly	76
In-Line Slitter Assembly	77
Solenoid Valve Assembly	78
Chill Idler Assembly	79
Cabinet & Cover Assembly	80
Rear Slitter Assembly	81
Separator Bar Assembly	82

NL

F

E

--	--	--

The information in this publication is provided for reference and is believed to be accurate and complete. GBC is not liable for errors in this publication or for incidental or consequential damage in connection with the furnishing or use of the information in this publication, including, but not limited to, any implied warranty of fitness or merchantability for any particular use.

GBC reserves the right to make changes to this publication and to the products described in it without notice. All specifications and information concerning products are subject to change without notice.

Reference in this publication to information or products protected by copyright or patent does not convey any license under the rights of GBC or others. GBC assumes no liability arising from infringements of patents or any other rights of third parties.

This publication is copyrighted © 2003 by GBC. All rights reserved. The information contained in this publication is proprietary and may not be reproduced, stored, transmitted, or transferred, in whole or in part, in any form without the prior and express written permission of GBC.

I

Le informazioni contenute in questo documento sono fornite a titolo di referenza e sono considerate corrette e complete. GBC non si responsabilizza di eventuali errori contenuti in questo documento, né di danni incidentali o conseguenti relazionati con la fornitura e l'uso delle informazioni in questo documento, includendo senza limitazioni qualsiasi garanzia d'idoneità o commerciabilità per qualsiasi uso particolare.

GBC si riserva il diritto di effettuare cambi a questo documento e ai prodotti in esso descritti senza preavviso. Tutte le specifiche e le informazioni sui prodotti sono soggette a cambio senza preavviso.

In questo documento le referenze a informazioni e prodotti protetti da diritti di proprietà intellettuale o brevetti non trasferiscono nessuna licenza alla quale abbiano diritto GBC o altri. GBC non assume nessuna responsabilità derivante dalla violazione di brevetti o di qualsiasi altro diritto di terzi.

Copyright © 2003 Questo documento è soggetto ai diritti di proprietà intellettuale di GBC. Riservati tutti i diritti. Le informazioni contenute in questo documento sono di proprietà esclusiva e non possono essere riprodotte, conservate, trasferite, in tutto o in parte ed in modo alcuno, senza la previa autorizzazione espressa e per iscritto di GBC.

D

Die Informationen in dieser Druckschrift werden als Richtlinien zur Verfügung gestellt und sind unseres Wissens richtig und vollständig. GBC lehnt jede Haftung für Fehler in dieser Druckschrift sowie für Schadenersatz oder Folgeschäden im Zusammenhang mit der Bereitstellung oder Verwendung der hierin enthaltenden Informationen ab, ein- aber nicht ausschließlich die Gewährleistung für Eignung und handelsübliche Qualität für einen bestimmten Zweck.

GBC behält sich das Recht vor, diese Druckschrift und die darin beschriebenen Produkte ohne Vorankündigung zu ändern. Alle die Produkte betreffenden Leistungsbeschreibungen und Informationen können jederzeit ohne Vorankündigung geändert werden.

Durch die Bezugnahmen in dieser Druckschrift auf urheberrechtlich oder durch ein Patent geschützte Informationen oder Produkte werden keine Rechte von GBC oder Dritten übertragen. GBC lehnt jede Haftung für Patentverletzungen sowie für die Verletzung anderer Rechte von Dritten ab.

Diese Druckschrift ist durch GBC urheberrechtlich geschützt (© 2003). Alle Rechte vorbehalten. Die Informationen in dieser Druckschrift sind gesetzlich geschützt und dürfen ohne vorherige und ausdrückliche schriftliche Genehmigung von GBC in keiner Weise weder ganz noch teilweise vervielfältigt, aufbewahrt, weiter verbreitet oder übertragen werden.

NL

De informatie in deze publicatie geldt slechts ter verwijzing en wordt nauwkeurig en volledig geacht. GBC is niet aansprakelijk voor fouten in deze publicatie of voor incidentele of voortvloeiende schade in verband met het verschaffen of gebruik van de informatie in deze publicatie, inclusief, maar niet beperkt tot stilzwijgende garanties van geschiktheid voor een bepaald doel of verkoopbaarheid.

GBC behoudt zich het recht voor om zonder voorafgaande kennisgeving wijzigingen te maken in de producten die hierin worden beschreven. Alle specificaties en informatie m.b.t. producten kunnen zonder voorafgaande kennisgeving gewijzigd worden.

Verwijzingen in deze publicatie naar informatie of producten beschermd door copyrights of patenten houdt geen licenties onder de rechten van GBC of anderen in. GBC is niet aansprakelijk voor schendingen van patenten of andere rechten van derden.

De publicatie is auteursrechtelijk beschermd, copyright © 2003 door GBC. Alle rechten voorbehouden. De informatie in deze publicatie is eigendom van GBC en mag niet verveelvuldigd, opgeslagen, overgebracht of overgedragen worden, geheel of gedeeltelijk, in welke vorm dan ook zonder voorafgaande en uitdrukkelijke schriftelijke toestemming van GBC.

F

L'information contenue dans cette publication est fournie à titre de référence et elle est considérée exacte et complète. GBC n'est pas responsable des erreurs contenues dans cette publication ni des dommages indirects ou consécutifs portant sur l'utilisation ou la présentation de l'information de ce document, y compris, mais sans s'y limiter, toute garantie implicite de commercialité ou d'adaptation à un usage particulier.

GBC se réserve le droit d'apporter des modifications à cette publication et aux produits qui y sont décrits sans préavis. Toutes les spécifications et l'information au sujet des produits sont sujettes à changements sans préavis.

Toute référence à l'information ou aux produits protégés par un droit d'auteur ou un brevet présentée dans ce document ne porte aucune licence sous les droits de GBC ou d'autres parties. GBC n'assume aucune responsabilité découlant de contraventions aux brevets ou à tout autre droit de tierces parties.

Cette publication est protégée par un droit d'auteur © 2003 de GBC. Tous droits réservés L'information contenue dans cette publication est privative et ne peut pas être reproduite, mise en mémoire, transmise ou transférée, en partie ou en entier, sous quelque forme que ce soit sans la permission écrite préalable et expresse de GBC.

E

La información contenida en esta publicación es proporcionada a título de referencia y se considera que es precisa y completa. GBC no es responsable por errores contenidos en esta publicación o por daños consecuentes o incidentales relacionados con la disponibilidad o el uso de la información en esta publicación, incluyendo y sin limitarse a, cualquier garantía de aptitud y comerciabilidad para cualquier uso específico.

GBC se reserva el derecho de hacer cambios en esta publicación y a los productos descritos en la misma sin aviso previo. Todas las características y la información referente a los productos, están sujetas a cambios sin aviso previo.

Las referencias en esta publicación a información o productos protegidos por derechos de propiedad intelectual o por patentes no otorga ninguna licencia amparada por los derechos de GBC u otros. GBC no asume ninguna responsabilidad que se derive de la violación de patentes u otros derechos de terceras partes.

Copyright © 2003 Esta publicación está amparada por derechos de propiedad intelectual de GBC. Todos los derechos reservados. La información contenida en este documento es de propiedad exclusiva y no puede reproducirse, almacenarse, transmitirse o transferirse, en su totalidad o en partes, y de ninguna manera, sin la autorización previa y por escrito de GBC.

IMPORTANT SAFETY INSTRUCTIONS

YOUR SAFETY AS WELL AS THE SAFETY OF OTHERS IS IMPORTANT TO GBC. IN THIS INSTRUCTION MANUAL AND ON THE PRODUCT, YOU WILL FIND IMPORTANT SAFETY MESSAGES REGARDING THE PRODUCT. READ THESE MESSAGES CAREFULLY. READ ALL OF THE INSTRUCTIONS AND SAVE THESE INSTRUCTIONS FOR LATER USE.

⚠ THE SAFETY ALERT SYMBOL PRECEDES EACH SAFETY MESSAGE IN THIS INSTRUCTION MANUAL. THE SYMBOL INDICATES A POTENTIAL PERSONAL SAFETY HAZARD TO YOU OR OTHERS, AS WELL AS PRODUCT OR PROPERTY DAMAGE.

THE FOLLOWING WARNINGS ARE FOUND UPON THIS PRODUCT.

⚠ ADVERTENCIA	⚠ ATTENTION		⚠ WARNING
Riesgo de choque eléctrico. No abra. Adentro no hay piezas reparables por el usuario. Mantenimiento solamente por personal calificado.	Risque de sévères blessures électriques. Ne pas ouvrir. Pas de pièces réparables par l'utilisateur. Entretien seulement par personnel qualifié.		Electrical shock hazard. Do not open. No user serviceable parts inside. Refer servicing to qualified service personnel.

THIS SAFETY MESSAGE MEANS THAT YOU COULD BE SERIOUSLY HURT OR KILLED IF YOU OPEN THE PRODUCT AND EXPOSE YOURSELF TO HAZARDOUS VOLTAGE.

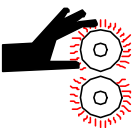
⚠ ADVERTENCIA	⚠ ATTENTION		⚠ CAUTION
RODILLOS CALIENTES. PUNTO DE PINCHAMIENTO. Mantener mano y ropa a distancia.	ROULEAUX CHAUDS. POINT DE PINCEMENT. Tenir mains et vêtements à l'écart.		HOT ROLLS. PINCH POINT. Keep hands and clothing away.

THIS SAFETY MESSAGE MEANS THAT YOU COULD BE BURNED AND YOUR FINGERS AND HANDS COULD BE TRAPPED AND CRUSHED IN THE HOT ROLLERS. CLOTHING, JEWELRY AND LONG HAIR COULD BE CAUGHT IN THE ROLLERS AND PULL YOU INTO THEM.

⚠ ADVERTENCIA	⚠ ATTENTION		⚠ CAUTION
NAVAJA FILOSA. Mantener mano y dedos a distancia.	LAME COUPANTE. Tenir mains et doigts à l'écart.		SHARP BLADE. Keep hands and clothing away.

THIS SAFETY MESSAGE MEANS THAT YOU COULD CUT YOURSELF IF YOU ARE NOT CAREFUL.

⚠ WARNING: THE SAFETY ALERT SYMBOL PRECEDES EACH SAFETY MESSAGE IN THIS INSTRUCTION MANUAL. THE SYMBOL INDICATES A POTENTIAL PERSONAL SAFETY HAZARD TO YOU OR OTHERS, AS WELL AS PRODUCT OR PROPERTY DAMAGE.

⚠ WARNING: DO NOT ATTEMPT TO SERVICE OR REPAIR THE ORCA 64 LAMINATOR.

⚠ WARNING: DO NOT CONNECT THE LAMINATOR TO AN ELECTRICAL SUPPLY OR ATTEMPT TO OPERATE THE LAMINATOR UNTIL YOU HAVE COMPLETELY READ THESE INSTRUCTIONS. MAINTAIN THESE INSTRUCTIONS IN A CONVENIENT LOCATION FOR FUTURE REFERENCE.

PRELIMINARY
COPY

IMPORTANT SAFEGUARDS



WARNING: TO GUARD AGAINST INJURY, THE FOLLOWING SAFETY PRECAUTIONS MUST BE OBSERVED IN THE INSTALLATION AND USE OF THE LAMINATOR.

General

Keep hands, long hair, loose clothing, and articles such as necklaces or ties away from the front of the heat and pull rollers to avoid entanglement and entrapment.

The heat rollers can reach temperatures over 300° F. Avoid contact with the heat rollers during operation or shortly after power has been removed from the laminator.

Keep hands and fingers away from the path of the sharp film cutter blade located at the film exit.

Do not use the laminator for other than its intended purpose.

Avoid moving the laminator on uneven floor surfaces. Never tilt the laminator.

Do not defeat or remove electrical and mechanical safety equipment such as interlocks, shields and guards.

Do not insert objects unsuitable for lamination or expose the equipment to liquids.

Electrical

The laminator should be connected only to a source of power as indicated in these instructions and on the serial plate located on the rear of the laminator.

Contact an electrician should the attachment plug provided with the laminator not match the receptacles at your location.



CAUTION: The receptacle must be located near the equipment and easily accessible.

Do not operate the laminator with a damaged power supply cord or attachment plug, upon occurrence of a malfunction, or after the laminator has been damaged. Contact GBC's Technical Service Department or your dealer/distributor for assistance.

Service

Perform only the routine maintenance procedures referred to in these instructions.



WARNING: Do not attempt to service or repair the laminator.

Disconnect the plug from the receptacle and contact GBC's Technical Department or your dealer/distributor when one or more of the following has occurred.

- The power supply cord or attachment plug is damaged.
- Liquid has been spilled into the laminator.
- The laminator is malfunctioning after being mishandled.
- The laminator does not operate as described in these instructions.

PRELIMINARY
COPY

WARRANTY

GBC warrants the equipment to be free from defects in material and workmanship for a period of **90 days for parts and labor** from the date of installation. This warranty is the only warranty made by GBC and cannot be modified or amended.

GBC IPFG's sole and exclusive liability and the customer's sole and exclusive remedy under this warranty shall be, at GBC IPFG's option, to repair or replace any such defective part or product. These remedies are only available if GBC IPFG's examination of the product discloses to GBC IPFG's satisfaction that such defects actually exist and were not caused by misuse, neglect, attempt to repair, unauthorized alteration or modification, incorrect line voltage, fire, accident, flood or other hazard.

Limited Warranty

This warranty specifically does not cover damage to the laminating rollers caused by knives, razor blades, other sharp objects, failure caused by adhesives or improper use of the machine. Warranty repair or replacement does not extend the warranty beyond the initial 90 day period from the date of installation.



WARNING: Unauthorized customer alterations will void this warranty.

THE WARRANTY MADE HEREIN IS IN LIEU OF ALL OTHER WARRANTIES, EXPRESSED OR IMPLIED, INCLUDING ANY WARRANTY OF MERCHANTABILITY OR FITNESS FOR A PARTICULAR PURPOSE. GBC WILL NOT BE LIABLE FOR PROPERTY DAMAGE OR PERSONAL INJURY (UNLESS PRIMARILY CAUSED BY ITS NEGLIGENCE), LOSS OF PROFIT OR OTHER INCIDENTAL OR CONSEQUENTIAL DAMAGES ARISING OUT OF THE USE OR INABILITY TO USE THE EQUIPMENT.

Exclusions to the Warranty

This warranty specifically does not cover;

1. Damage to the laminating rollers caused by knives, razor blades, other sharp objects or failure caused by adhesives.
2. Damage to the machine caused by lifting, tilting and/or any attempt to position the machine other than rolling on the installed castors on even surfaces.
3. Improper use of the machine.
4. Damage due from unqualified person(s) servicing the machine.

QUALIFIED: Any person(s) trained by GBC to perform service related work on such equipment.

For European Union Residents Only: This guarantee does not affect the legal rights which consumers have under applicable national legislation governing the sale of consumer goods.

PRELIMINARY
COPY

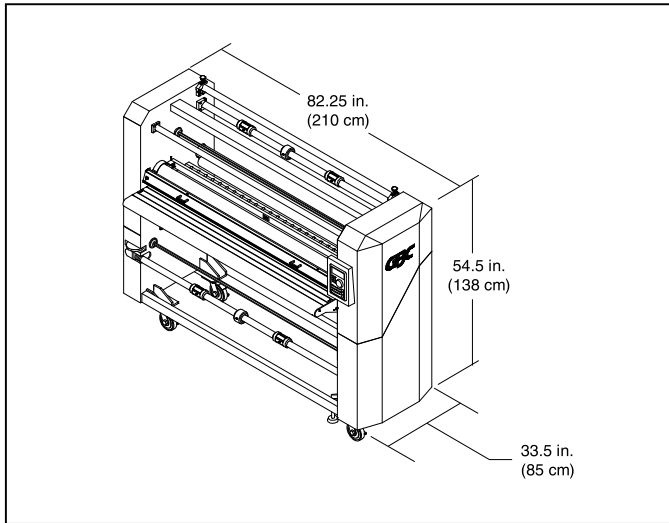

Fig. 1

SPECIFICATIONS

Operating Speed:

0 fpm to 10 fpm (3mpm)

Maximum Film Width:

64 in. (163 cm)

Maximum Temperature:

300 °F (149 °C)

Dimensions (W x L x H):

Unit alone: (Figure 1)

82.25 in. x 33.5 in. x 54.5 in.

(210 cm x 85 cm x 138 cm)

Shipping:

88.5 in. x 45 in. x 75.5 in.

(225 cm x 114 cm x 192 cm)

Weight:

Unit alone: 1468 lb. (666 kg.)

Shipping: 1797 lb. (815 kg.)

Electrical Requirements:

Refer to the serial plate located on the rear of the laminator for the specific electrical rating applicable to the unit.

Voltage: 220V-60 Hz**Current:** 25A**Power:** 5500 W**Phase:** Single**Air Requirements:**

Filtered air at 3 cfm (85 lpm) with 100 psi (700 kpa) of pressure.

PRELIMINARY
COPY

PRE-INSTALLATION

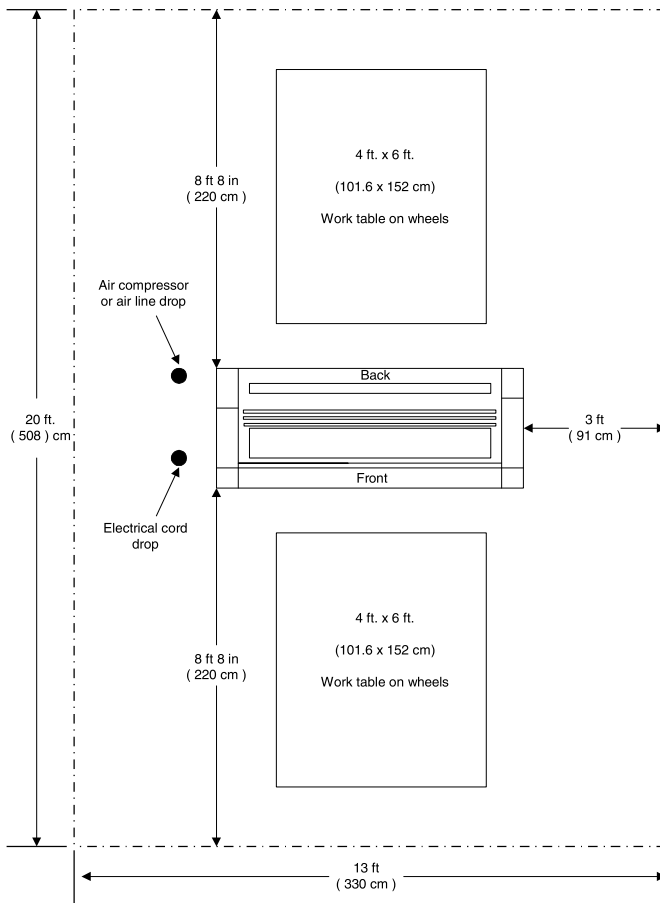

Fig. 2

Before an Orca 64 Laminator can be installed, ensure the following requirements are met;

1. Are door ways and hallways wide enough for the laminator to be moved to the installation site?
2. Is there ample room for the laminator?
 - A work area must be established that allows for operation in both the front and rear of the laminator and provides space for efficient material flow. (Figure 2)
3. Is the environment appropriate for the laminator?
 - The laminator requires a clean, dust and vapor free environment to operate properly.
 - Avoid locating the laminator near sources of heat or cold. Avoid locating the laminator in the direct path of forced, heated or cooled air.

⚠ Air flow can cause uneven heating/ cooling of the rollers and result in poor output quality.

4. Have you contacted a certified electrician to wire the receptacle and ensure that adequate power is being supplied, having the appropriate capacity, over current protection and safety lockouts available?
 - 220V at 60hz with 30 amp service. Use a Nema 6-30R
5. Do you have appropriate air supplied to the installation site?
 - Filtered air at 3 cfm (85 lpm) with 100 psi (700 kpa) of pressure.

⚠ The air supply must be clean and dry or the machine will be damaged.

PRELIMINARY
COPY

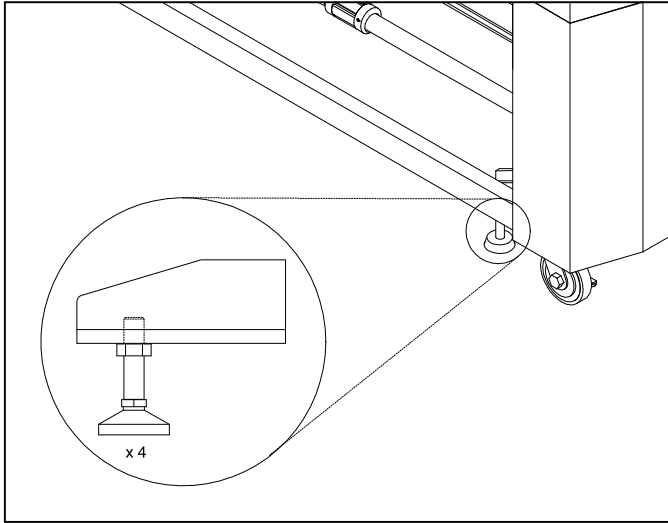

Fig. 3

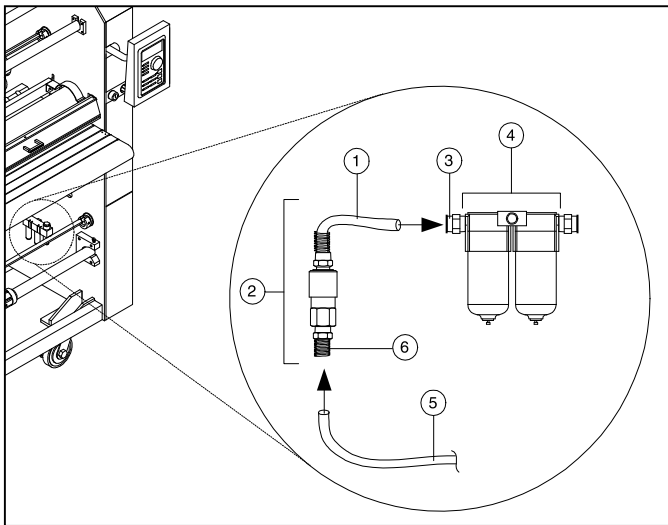

Fig. 4

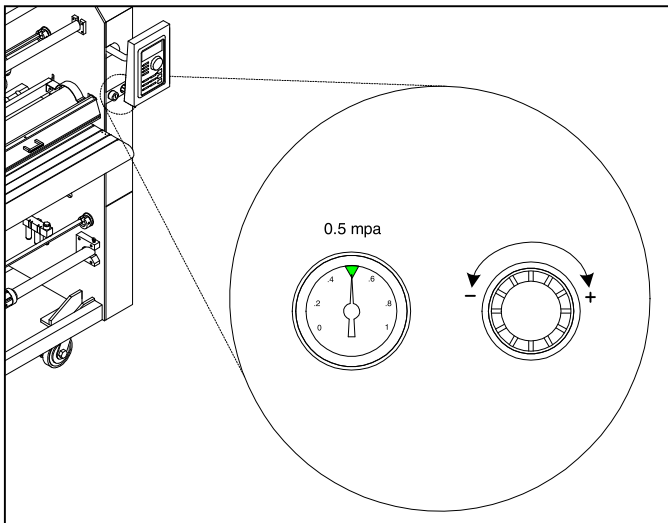

Fig. 5

INSTALLATION

1. **Shipping damage should be brought to the immediate attention of the delivering carrier.**
2. With assistance, carefully roll the laminator into position over flat and even surfaces.
3. The laminator should be positioned to allow exiting film to flow freely to the floor or a work table. Accumulation of laminate immediately behind the laminator as it exits the equipment may cause the film to wrap around the pull rollers, resulting in a "jammed" condition.
4. Avoid locating the laminator near sources of heat or cold. Avoid locating the laminator in the direct path of forced, heated or cooled air.
5. Leveling of the machine is a customer option. If you choose not to level the laminator and encounter output problems, please level the machine and try your application again before calling for technical support. Resting the laminator on the leveling pads prevent the machine from rolling during set up, operation or servicing. (Figure 3)
6. Connect the attachment plug provided with the laminator to a suitably grounded outlet. **Avoid connecting other equipment to the same branch circuit to which the laminator is connected, as this may result in nuisance tripping of circuit breakers or blowing fuses.**
7. Connect the pneumatic tube (1) from the included coupler kit (2) to the input side (3) of the filter assembly (4). (Figure 4)
8. Connect air from your compressor (5) to the opposite end (6) of the included coupler kit. (Figure 4)
9. Set the laminator main air regulator pressure to 0.5 mpa. (Figure 5)

PRELIMINARY
COPY

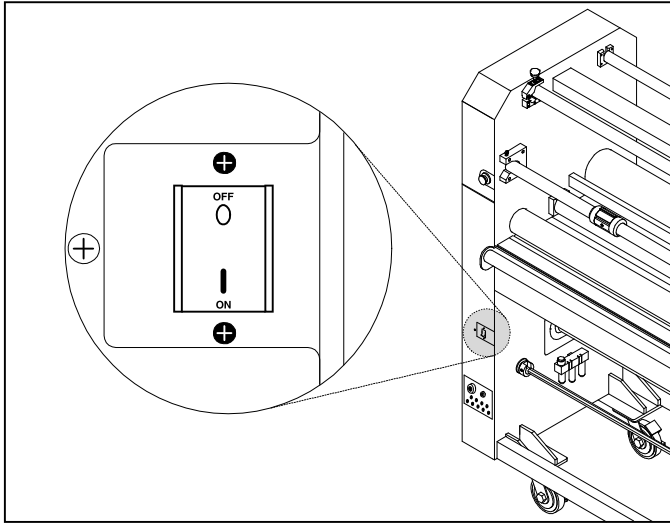

Fig. 6

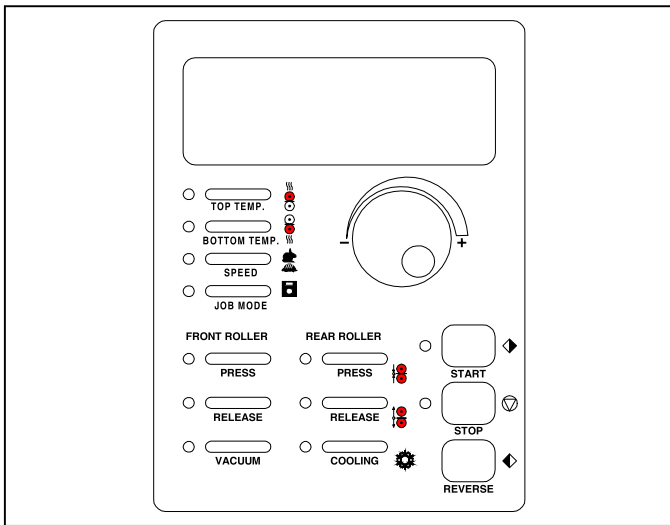

Fig. 7

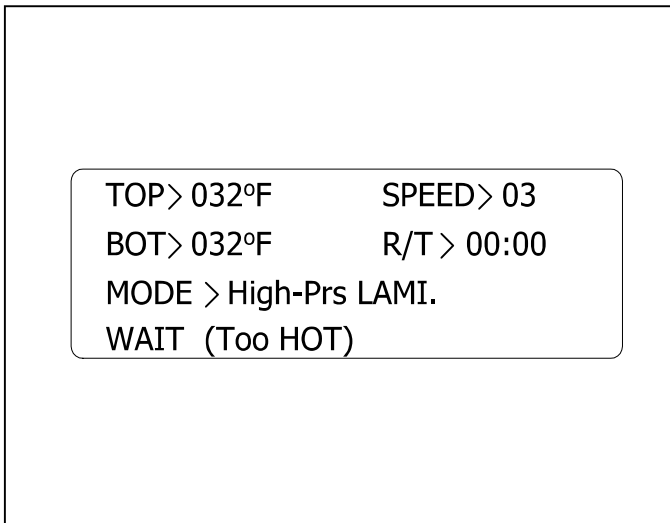

Fig. 8

FEATURES GUIDE

A. POWER ON/ OFF: (Figure 6)
 Located at the back left of the machine applies power to the laminator. The control panel display will illuminate when position marked "I" is pushed. The off position, marked "O", removes power from the laminator.

B. CONTROL PANEL: (Figure 7)

CONTROL PANEL DISPLAY: (Figure 8) Illuminates when the laminator is plugged in and **POWER ON/ OFF** is in the on, (I), position. Displays settings for top heater, bottom heater, speed, run time, mode and ready/ wait indicator.

READY/ WAIT INDICATOR:
"READY" appears when actual temperature is equal to (+/- 5) set temperature. **"WAIT (Too COLD)"** appears when actual temperature is lower than the set temperature. **"WAIT (Too HOT)"** appears when actual temperature is higher than the set temperature.

R/T: Run time is monitored when the rollers are turning. This value is reset once **POWER ON/ OFF** is pressed to the **OFF (O)** position.

MASTER DIAL ☺: Increases (+) or decreases (-) the numeric value for the selected setting when turned. When **JOB MODE** 🗄 is selected, scrolls through the available modes when turned.

Press and hold the **MASTER DIAL** ☺ to display actual temperature of top and bottom heaters.

TOP TEMP 🔴: This means top roller temperature. When pressed, permits increasing or decreasing of the top temperature by turning the **MASTER DIAL** ☺. Temperature range is 32°F - 320°F (0°C - 160°C).

BOTTOM TEMP 🔴: This means bottom roller temperature. When pressed, permits increasing or decreasing of the bottom temperature by turning the **MASTER DIAL** ☺. Temperature range is 32°F - 320°F (0°C - 160°C).

SPEED 🐞: This means machine roller speed. When pressed, permits increasing or decreasing of speed by turning the **MASTER DIAL** ☺. Speed range is 01 - 10.

PRELIMINARY
COPY

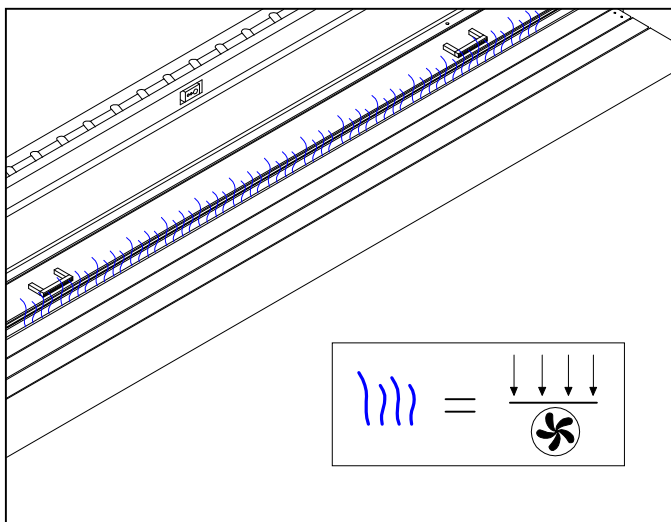

Fig. 9

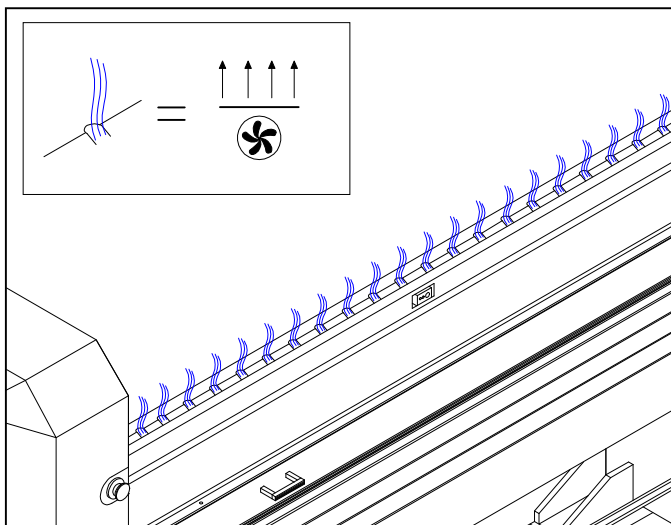



Fig. 10

JOB MODE  : When pressed, permits scrolling of available modes by turning the **MASTER DIAL** .

Available modes are;

- High-Prs Laminating
- Mid-Prs Laminating
- Low Prs Laminating
- 1/8 in. Mounting
- 3/16 in. Mounting
- 5/16 in. Mounting
- 3/8 in. Mounting
- 5/8 in. Mounting
- 13/16 in. Mounting
- 1 in. Mounting

Speed, top and bottom temperatures may be saved for each of the job modes by changing the values and then pressing job again.

When pressed and held, changes **Mid-Prs Laminating** to **Mid-Prs Accushield**. Heat and speed are automatically set in this mode.

FRONT ROLLER "PRESS"  :

This means front upper roller lower. When pressed, lowers the upper front roller with respect to the **JOB MODE**  selection.

FRONT ROLLER "RELEASE"  :

This means front upper roller raise. When pressed, raises the upper front roller.



REAR ROLLER "PRESS"  :

This means rear upper roller lower. When pressed, lowers the upper rear roller with respect to the **JOB MODE**  selection.

REAR ROLLER "RELEASE"  :

This means rear upper roller raise. When pressed, raises the upper rear roller.

"VACUUM" : When pressed, turns on the vacuum table fans. When pressed again, turns off the vacuum fans. (Figure 9) To adjust vacuum level, press and hold **"VACUUM"** while rotating the **MASTER DIAL**  to desired amount.

COOLING  : When pressed, turns on the cooling fans. When pressed again, turns off the cooling fans. (Figure 10) To adjust cooling level, press and hold **COOLING**  while rotating the **MASTER DIAL**  to desired amount.

PRELIMINARY
COPY

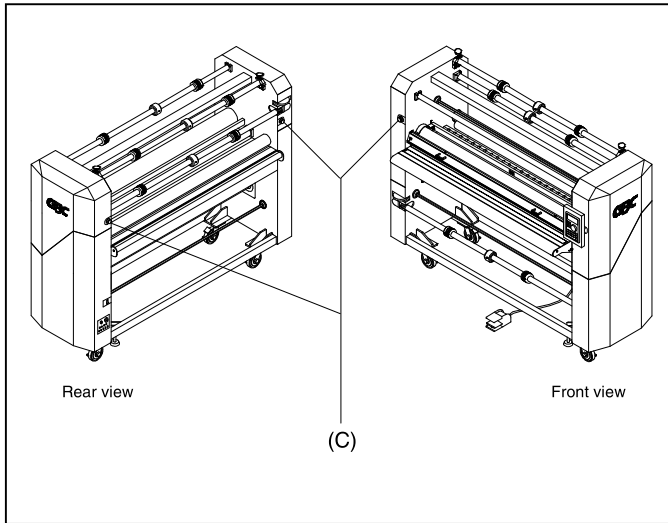

Fig. 11

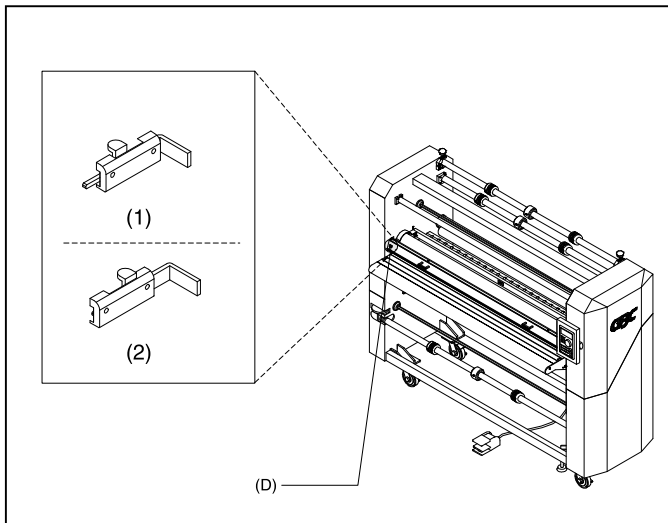

Fig. 12

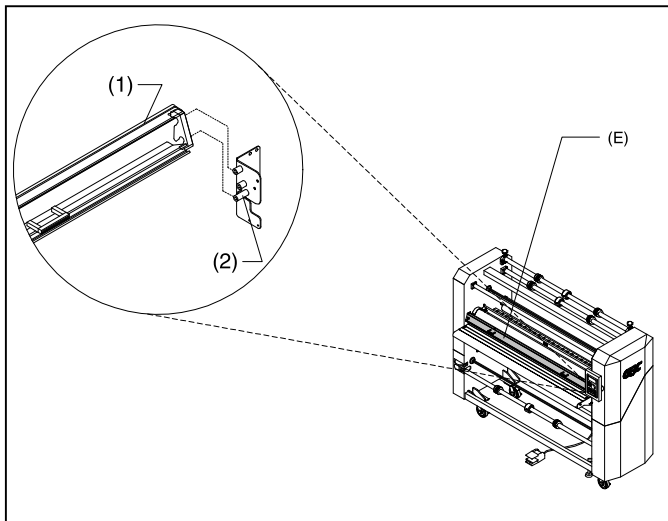

Fig. 13

START ◀: When pressed, activates rollers for normal operation.

STOP Ⓢ: Stops the movement of the rollers.

REVERSE ▶: When pressed, reverses roller movement to clear film jams and wrap-ups.

STAND-BY: Stand-by can be initiated manually or automatically. Stand-by is initiated automatically after 3 hours of no motor movement is detected. In **STAND-BY** mode, the temperature of the heaters is reduced to below 180 °F (82 °C). After an additional 1 hour, the laminator shuts off.

To manually initiate **STAND-BY** mode, press **JOB MODE** [] and

REAR ROLLER "PRESS" [] simultaneously. **STAND-BY!** is indicated on the control panel display in place of wait.

To revert to normal operating mode from **STAND-BY** mode, press **START** ◀.

C. E-STOP: Three emergency stop buttons exist on the laminator. One located at the right front and two at the rear. (Figure 11)

To engage, press any emergency stop push button. The heat rollers gap and power to the motor is removed. To dis-engage, pull out on the push button.

D. SAFETY SHIELD INTERLOCK LATCH: (Figure 12) Used to lock the safety shield into position and activate an interlock switch. The interlock latch is located on the left side of the safety shield. When pushed to the full left (1), the safety shield is locked. When pushed to the full right (2), the safety shield is unlocked.

E. SAFETY SHIELD: (Figure 13) Prevents entanglement, entrapment and inadvertent contact with the heat rollers. **The laminator will operate only when the Safety Shield is located in the fully locked and closed position. Power to the motor is removed when the shield is in the open position or the interlock latch is unlocked.**

To remove the safety shield, unlock the safety shield interlock latch and lift the the safety shield (1) up and away from the safety shield mounting pins (2).

PRELIMINARY
COPY

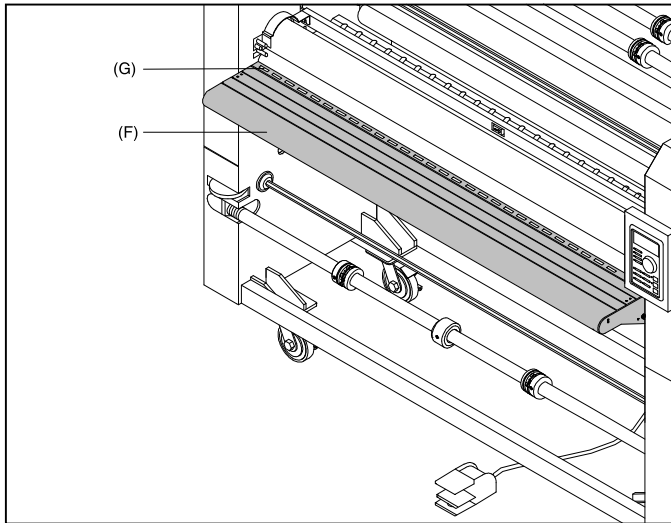

Fig. 14

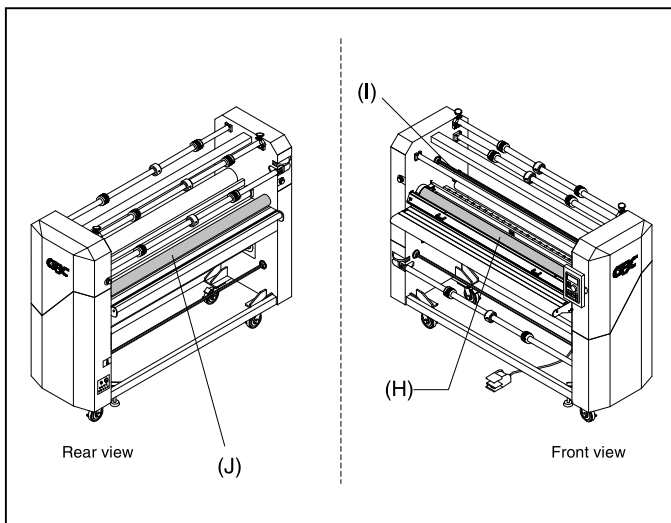

Fig. 15

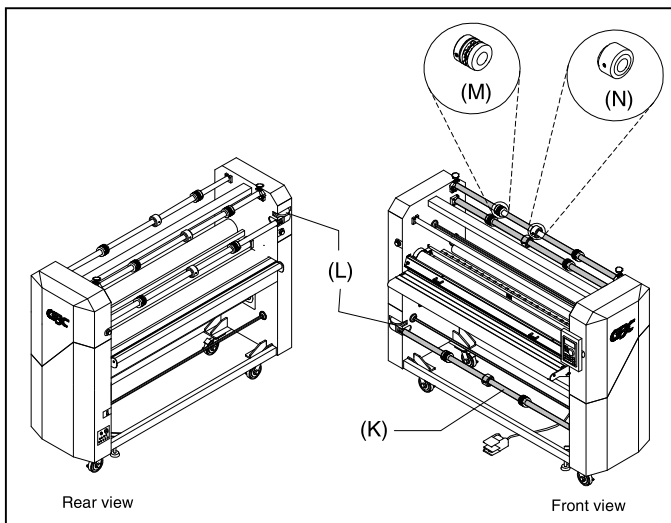

Fig. 16

F. FEED TABLE: (Figure 14) The Feed Table is used to position items for lamination. To pivot the feed table, remove the safety shield, lift up on the feed table, pull back, then carefully lower. **The laminator will operate only when the Feed Table is properly installed.**

G. VACUUM: (Figure 14) The vacuum is used to assist in keeping the material flat against the feed table as it is introduced into the heat rollers. This feature can be controlled from the control panel.

H. HEAT ROLLERS: (Figure 15) Silicone rubber coated steel tubes heat the laminating film and compress the heated film to the items being laminated. Heat is provided by an internal heating element. The heat rollers are motor driven for ease of loading new film.

I. IDLER BAR: (Figure 15) The idler bars, located near each heat roller, are used to direct the film to the heat roller nip. The bottom Idler Bar is movable to ease film loading.

J. PULL ROLLERS: (Figure 15) The pull rollers, located at the back of the laminator, are motor driven. They simultaneously pull the film and improve the quality of the laminated item.

K. FILM SHAFT: (Figure 16) The film shaft holds the film supply on the machine.

L. FILM SHAFT BRAKE: (Figure 16) Used to apply resistance to the film shaft. One for the primary upper unwind and one for the lower unwind.

To increase film shaft brake, turn the film shaft brake dial clockwise. Counter clockwise will decrease film shaft brake tension.

M. CORE ADAPTORS: (Figure 16) Hold and lock the rolls of film on the shafts to prevent side to side shifting.

N. CENTER CORE SUPPORT: (Figure 16) Supports the center of the film cores when placed onto the unwind shafts.

PRELIMINARY
COPY

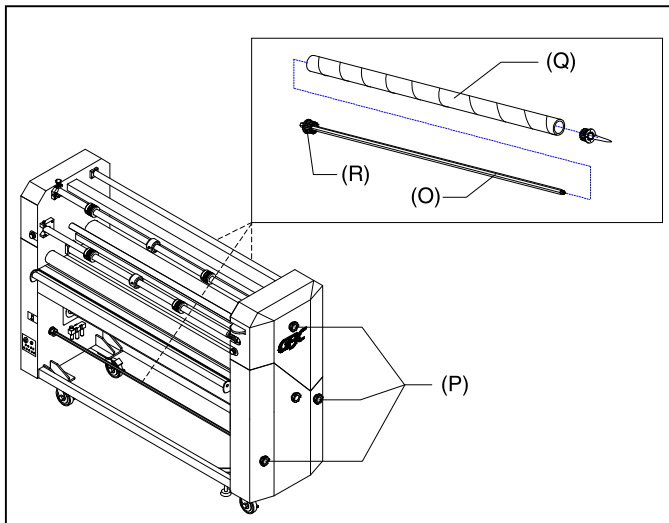

Fig. 17

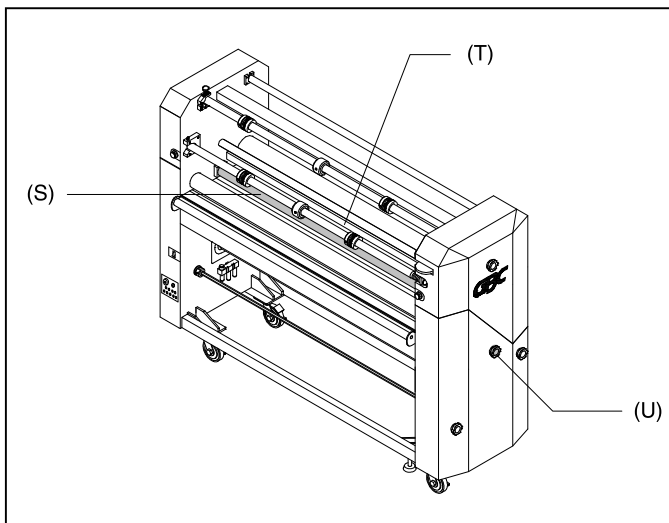

Fig. 18

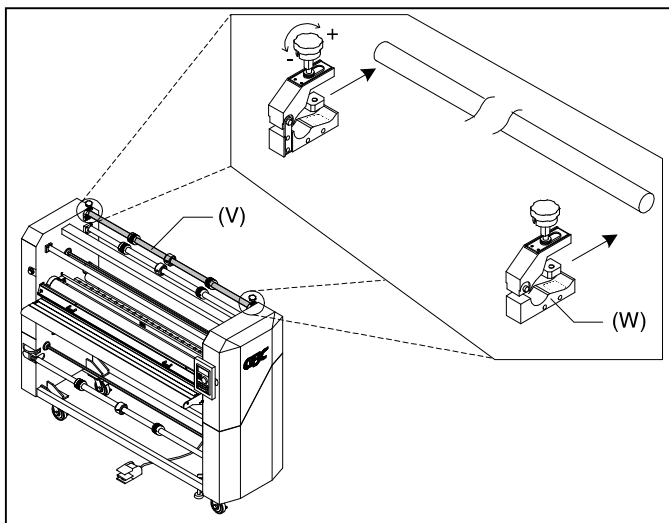

Fig. 19

O. REWIND SHAFT: (Figure 17) The rewind shaft holds the rewind tube on the machine.

To remove any one of the three rewind shafts, turn the outer dial opening so it aligns with the inner u-channel opening.

P. REWIND BRAKE: (Figure 17) Located on the left side from the front operating position.

Turn clockwise to increase rewind brake tension. Counter clockwise will decrease rewind brake tension.

Q. REWIND TUBE: (Figure 17) The two rewind tubes located at the front of the machine are used to rewind release liners. The one located at the rear of the machine is used to rewind the finished product.

R. REWIND ADAPTORS: (Figure 17) Hold and lock the rewind tube on the rewind shafts to prevent side to side shifting.

S. CHILL IDLER: (Figure 18) Assist in the cooling process of the web material as it exits the heat rollers.

To remove the chill idler, lift the chill idler straight up and out from the chill idler brackets.

The chill idler can be stored in the accushield position located just above the safety shield. Refer to **Tips For Accushield** on page 42.

T. COOLING FANS: (Figure 18) Assist in the cooling process by pushing unheated air onto the web material as it exits the heated rollers. This feature can be controlled from the control panel.

U. CLUTCH: (Figure 18) Used to increase or decrease pull roller clutch tension. Clockwise rotation increase while counterclockwise rotation decreases clutch tension.

V. SECONDARY UPPER UNWIND: (Figure 19) Used when requiring brake tension from both end of the film roll (ie. Micronex®). Unlike the primary unwinds, this unwind must be removed from the laminator to load film.

W. SECONDARY UPPER UNWIND BRAKE TENSION: (Figure 19) Used to apply brake tension to the secondary upper unwind shaft. Left and right brakes allow for

PRELIMINARY
COPY

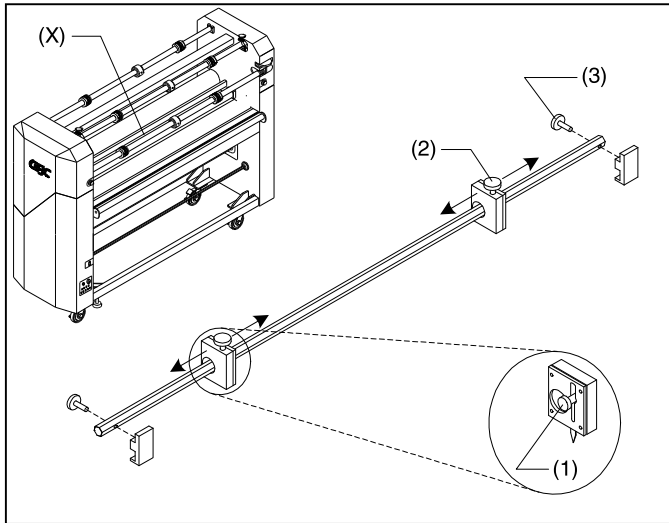

Fig. 20

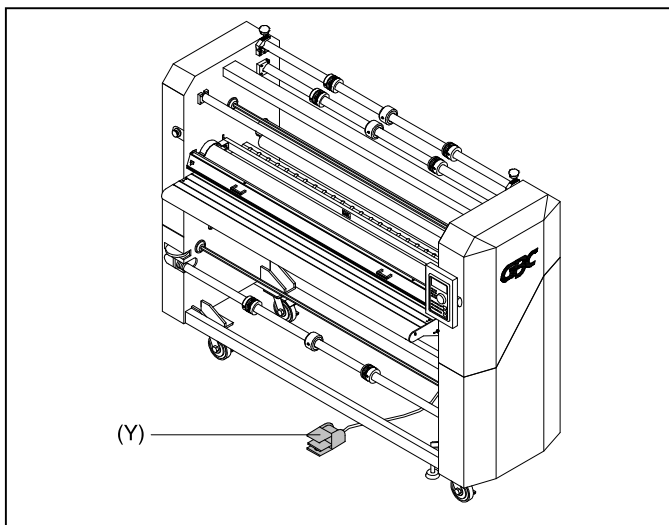

Fig. 21

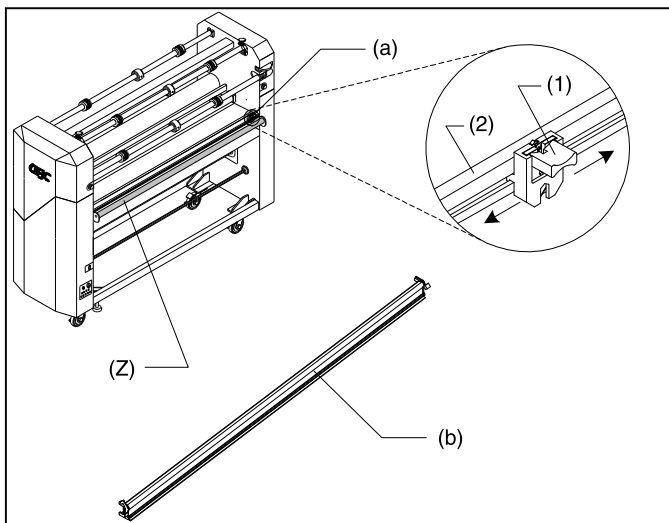

Fig. 22

independent braking.

X. INLINE SLITTERS: (Figure 20)
Used to cut excess film from the left and right sides of the web between the main rollers and pull rollers.

To engage, push the engage knob (1) down and rotate 1/2 turn to secure.

To disengage, rotate the engage knob 1/2 turn.

To position, loosen the slitter lock down knob (2), slide to desired position then secure.

Loosen the two slitter shaft lock down knobs (3) to remove the inline slitter assembly.

Y. FOOTSWITCH: (Figure 21)
When in **Footswitch mode**, pressing on the footswitch will turn the rollers.

To enable **Footswitch mode**, press and hold **STOP**  for approximately 3 seconds. The machine will be and **Footswitch Enabled** will appear on the control panel display in place of **WAIT**.

When all safety is in place, the laminator will run at current speed setting. With safety out, speed is reduced to 1mpm.

Z. EXIT IDLER: (Figure 22)
Provides a smooth rolling surface for the output web to move across during roll to roll applications.

a. REAR SLITTER: (Figure 22)
Used to cut off the laminated web. To use, push down on the blade engage lever (1) and slide across the rear slitter rail (2) to the opposite side.

b. SEPARATOR BAR: (Figure 22)
Required if running Accushield® material. To install, remove the rear slitter and position the separator bar in its place.

c. FILM WEB: Laminating film loaded into the machine.

d. NIP POINT: The point at which the top and bottom rollers come into contact. The Nip Point of the heat rollers is the place at which the items for lamination are introduced into the laminator.

PRELIMINARY
COPY

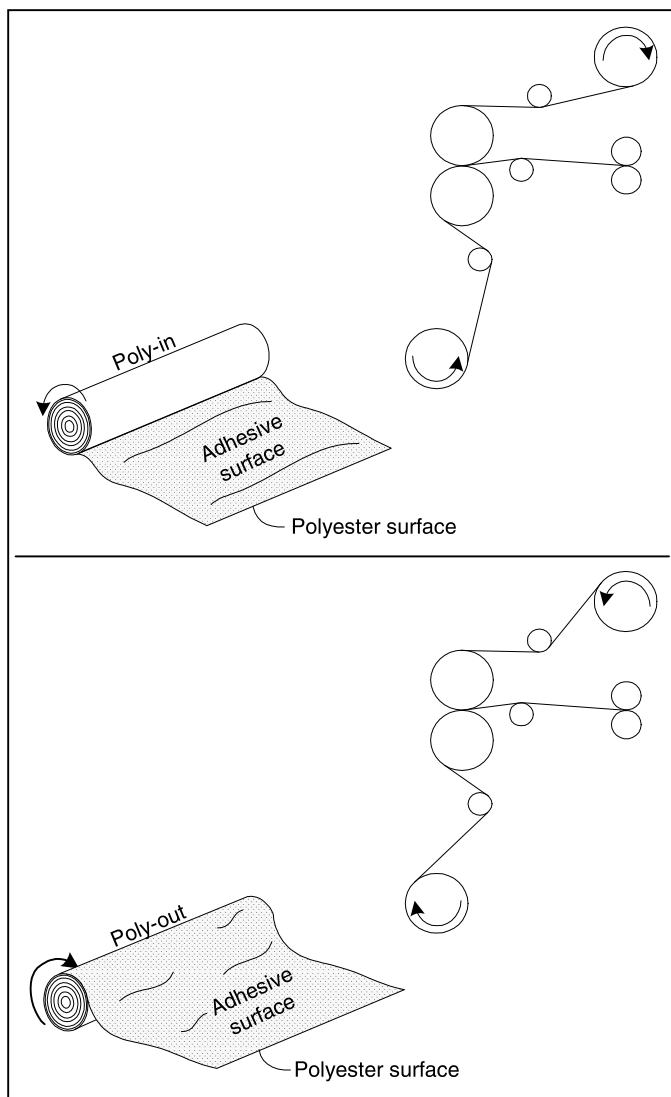

Fig. 23

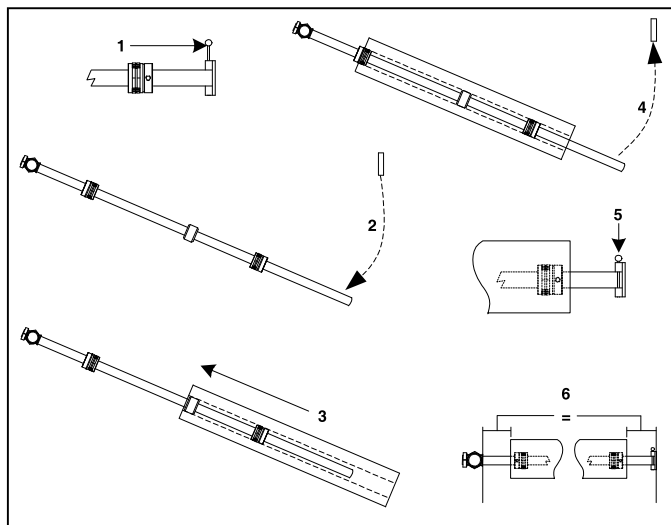

Fig. 24

OPERATING INSTRUCTIONS

FILM LOADING & THREADING

The top and bottom rolls of laminating film must be of the same width and be present simultaneously. A small amount of adhesive will “squeeze out” during lamination. Hardened adhesive deposits can damage the heat rollers. To avoid any damage, select “Low-Prs LAMI.” for job mode (■), rotate the rollers at slowest speed with heat on. Refer to the section entitled **CARING FOR THE ORCA 64 LAMINATOR** for instructions regarding removal of the accumulated adhesive.

Adhesive will deposit on the rollers if:

- Only one roll is used.
- Different widths of rolls are loaded together.
- Either roll is loaded adhesive side against a heat roller.
- One or both rolls of film are allowed to run completely off its core.

The adhesive side of the film is on the inner side of the web (Figure 23). The shiny side of clear film must contact the heat rollers. The dull side of the film contains the adhesive. Use extreme caution when loading delustered (matte) film as both sides appear dull.

Always change the top and bottom supply rolls at the same time. Near the end of each roll of GBC laminating film is a label stating “Warning-End of Roll”. The appearance of this label on either the top or bottom roll requires that new rolls of film be installed as soon as the item presently being laminated completely exits the rear of the laminator. Do not introduce any additional items into the laminator when the warning label is visible.

To load a roll of film; (Figure 24)

1. Pull the clevis pin up.
2. Swing shaft outward.
3. Slide the roll of film onto the film shaft ensuring adhesive side is out.
4. Push the film shaft back into the film shaft support saddle.
5. Push the clevis pin down.
6. Center the roll of film.

PRELIMINARY
COPY

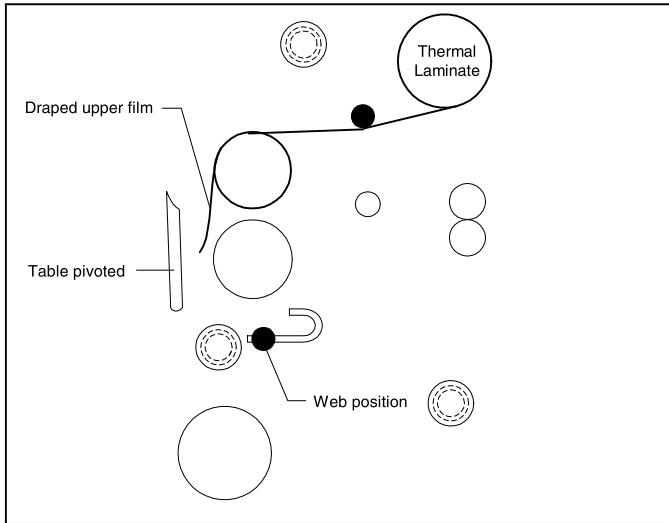

Fig. 25

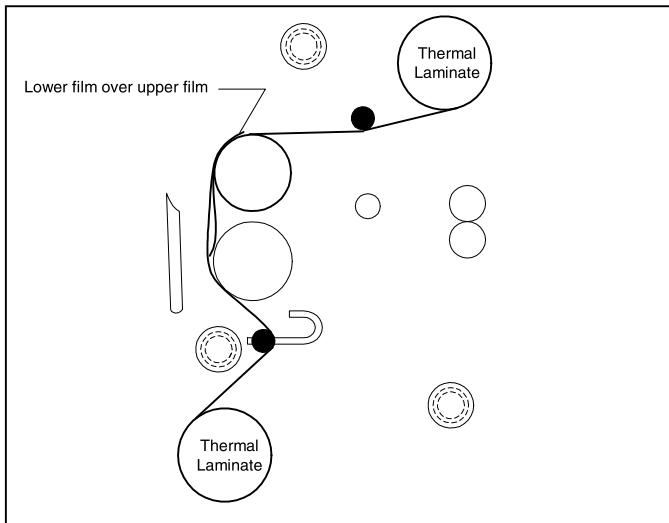

Fig. 26

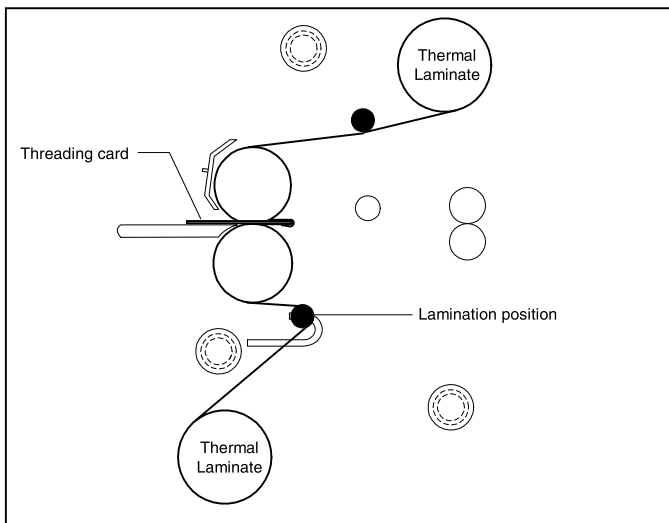

Fig. 27

WEBBING THERMAL FILM USING THREADING CARD

The following procedure uses the film threading card provided with new rolls of GBC film. The laminator rollers will be hot for this procedure. For pressure sensitive film (PSA), refer to the section entitled **WEBBING USING FILM THREADING CARD FOR PSA FILM.**

1. Turn the **Power ON/OFF** to on (I).
2. Select a job mode (■) or enter a top and bottom temperature with regards to the film type used.
2. Ensure no brake tension is applied to the film shafts.
3. Remove the safety shield and pivot the feed table down.
4. Pull the top roll of film down under the upper idler bar and allow to drape over the top heat roller (Figure 25).
5. Move the lower idler bar to the thread film position.
6. Pull the lower film behind the lower idler bar and up towards the film draped over the top heat roller (Figure 26).
7. Use a threading card to push the two materials through the heat roller nip.
8. Pivot the table back to its feeding position while ensuring the threading card is on top of the feed table (Figure 27).
9. Move the lower idler bar into the lamination position.
10. Replace the safety shield.
11. Set speed to 3 or less.
12. Push the front roller **"PRESS"** (⏻) button to close the heat rollers.
13. Push the start (▶) button.
14. From the rear of the machine, guide the web over the chill idler, if installed, under the inline slitter bar and through the pull rollers.
15. Push the front roller **"RELEASE"** (⏹) button then the stop (⏻) button.
16. Now refer to the section entitled **START LAMINATING.**

PRELIMINARY
COPY

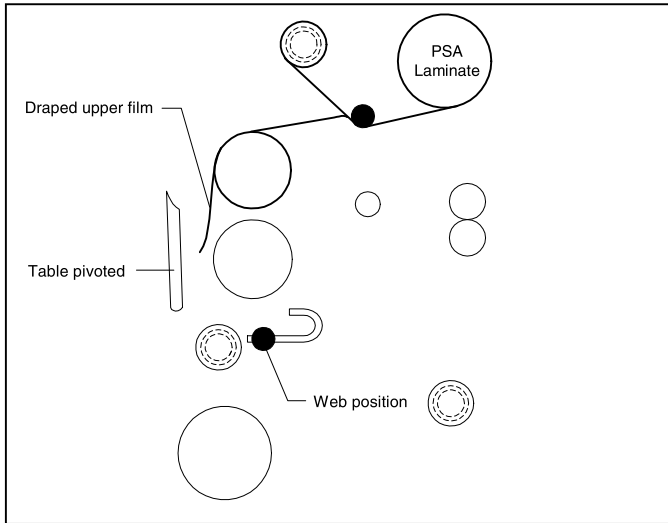

Fig. 28

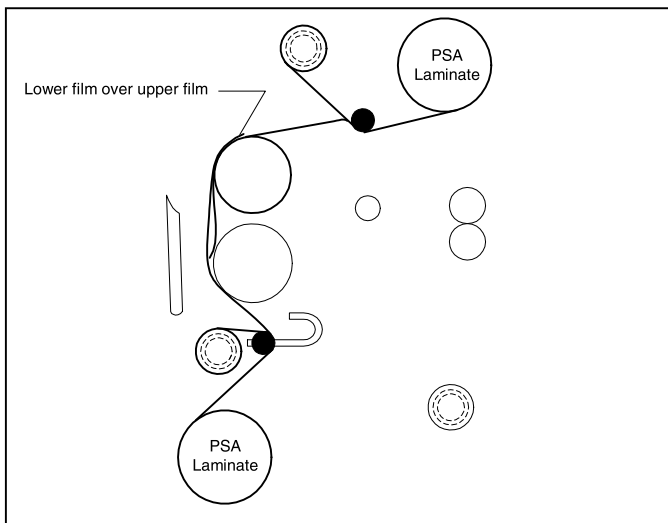

Fig. 29

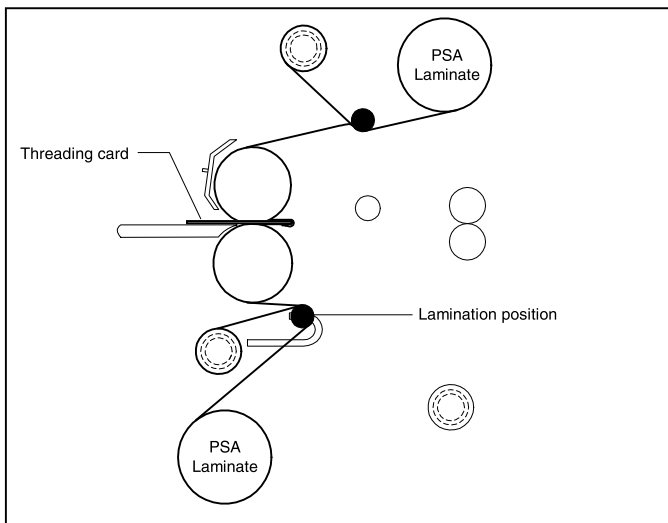



Fig. 30

WEBBING PSA FILM USING THREADING CARD

The laminator should be cool to the touch before proceeding.

1. Turn the **Power ON/OFF** to on (**I**). If the laminator is already hot, turn **POWER ON/OFF** to the off (**O**) position and allow the unit to cool. Once cool, turn the laminator back on.
2. Ensure no brake tension is applied to the film shafts.
3. Remove the safety shield and pivot the feed table down.
3. Pull the top roll of film down under the idler bar and up the upper front rewind tube.
4. Place one piece of masking tape in the center of the film and secure to the rewind tube.
5. Make two full wraps around the rewind tube, then carefully score the laminate without cutting the release liner. Pull the laminate down allowing it to drape over the upper heat roller (Figure 28).
6. Move the lower idler bar to the thread film position.
7. Pull the lower film behind the lower idler bar and up towards the front lower rewind tube.
8. Make two full wraps around the rewind tube, then carefully score the laminate without cutting the release liner. Pull the laminate up towards the film draped over the upper heat roller (Figure 29).
9. Use a threading card to push the two materials through the heat roller nip.
10. Pivot the table back to its feeding position while ensuring the threading card is on top of the feed table (Figure 30).
11. Move the lower idler bar into the lamination position.
12. Replace the safety shield.
13. Set speed to 3 or less.
14. Push the front roller "**PRESS**" () button to close the heat rollers.
15. Push the start () button.

PRELIMINARY
COPY

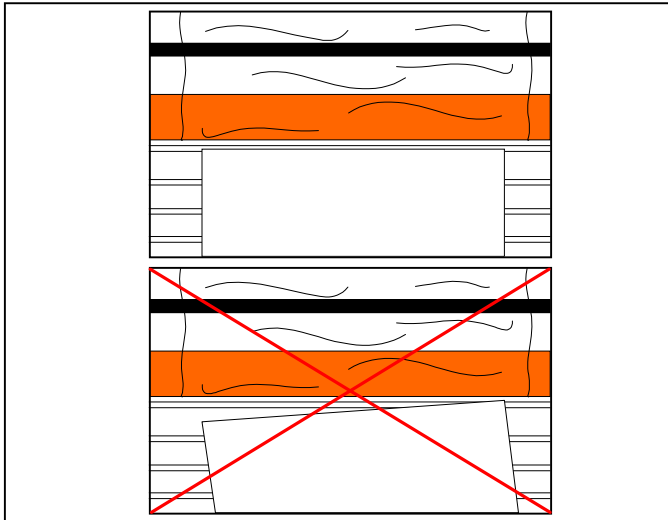

Fig. 31

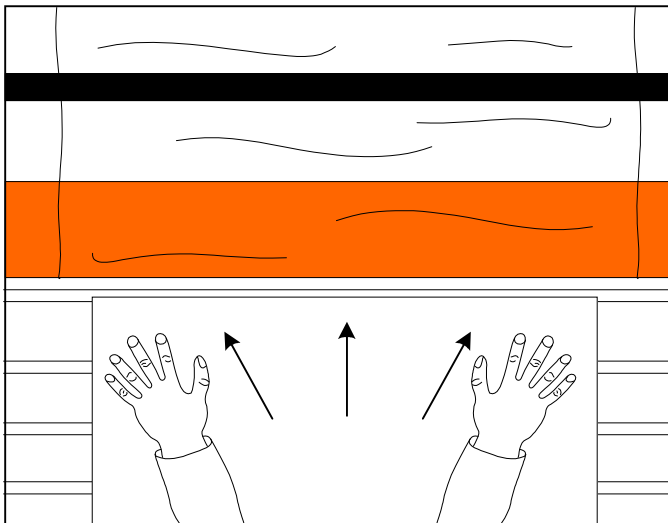

Fig. 32

16. From the rear of the machine, guide the web over the chill idler, if installed, under the inline slitter bar and through the pull rollers.
17. Adjust the rewind brake so that the laminate separates from the release liner just above the heat roller for the upper material and just below the heat roller for the lower material.
18. Push the front roller and rear roller "RELEASE" (🔴) buttons. Then the stop (🛑) button.
19. Now refer to the section entitled **START LAMINATING**.

START LAMINATING

1. At this point you should have your laminator webbed with the appropriate material for your application.
2. The safety shield and feed table should be in the normal operating position.
3. Select a job mode (📁) and ensure the proper speed and temperatures are set. Refer to the section entitled **SPEED/TEMPERATURE GUIDE**.
4. Push the rear roller "PRESS" (🔴) button.
5. Push the start button (▶).
6. Push the front roller "PRESS" (🔴) button.
7. Make any necessary film brake tension and/ or rewind brake tension adjustments to achieve desired output quality. Refer to the section entitled **SPEED/TEMPERATURE GUIDE**.
8. Position the item to be laminated on the feed table.
9. Align the leading edge of the item square to the heat roller nip (Figure 31).
10. With both hands and an outward force push the image slower than the speed of the rollers into the nip of the heat rollers (Figure 32).

CAUTION: Avoid forcing the image into the heat roller nip.

PRELIMINARY
COPY

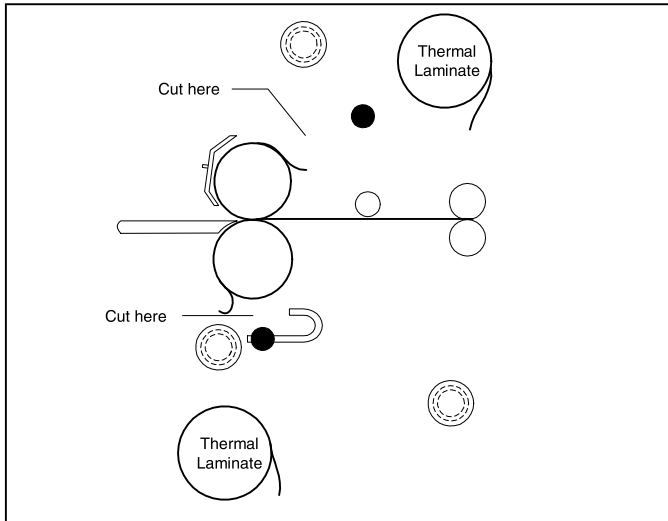

Fig. 33

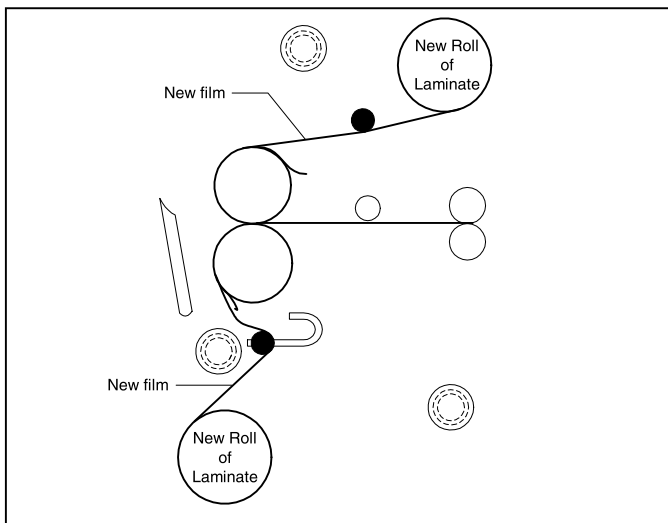

Fig. 34

METHOD FOR TACKING NEW FILM TO EXISTING FILM

The following describes a method for loading film whereby the existing film present on the heat rollers may be used in place of the threading card to draw the new film through the laminator. The adhesive of the existing film must be tacky or liquefied. Leading edges of the new film will be overlapped onto the tacky adhesive of the old film. The existing film and the new film will be pulled through the laminator together.

1. Cut remaining top film web between the idler bar and heat roller. Move the lower idler bar to the web position and cut the film web between the lower heat roller and the idler bar (Figure 33).

CATION: DO NOT CUT THE HEAT ROLLERS WHEN CUTTING THE FILM WEB.

2. Remove the safety shield and tilt the feed table down.
3. Do not allow the adhesive side of the film to contact the heat or pull rollers. Liquefied or tacky adhesive deposited on heat rollers will require the rollers to be cleaned per the section entitled **CARING FOR THE ORCA 64 LAMINATOR**.
4. Replace both the top and bottom rolls of film with new rolls. Ensure the adhesive side is facing out.
5. Pull the film around the idler bars, with the exception of PSA mounting adhesives without a release liner.
6. Tack the new film to the existing film on the heat rollers. For PSA film, Pull the release liner up and attach to the rewind tube (Figure 34).
7. Use the footswitch to advance the film into the heat roller nip.
8. Observe the film being pulled through the laminator to assure that the remaining existing film and the new film are advancing concurrently. Any separation between the films will require stopping the motor immediately and the situation corrected.
9. Press **STOP** (⏹) once the newly threaded film has completely exited the pull rollers.

PRELIMINARY
COPY

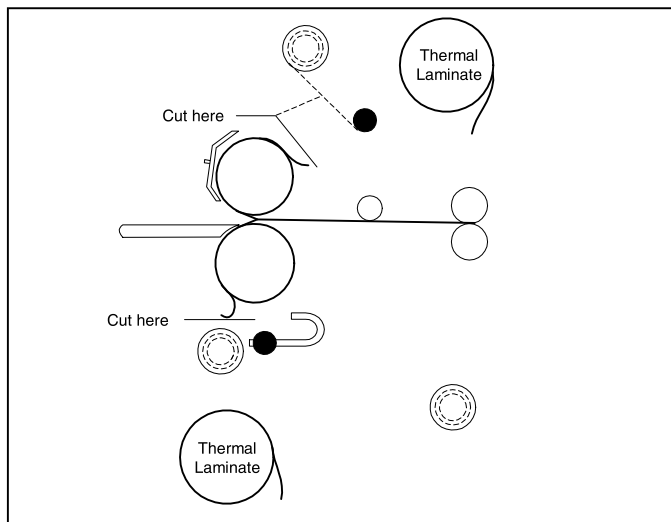

Fig. 35

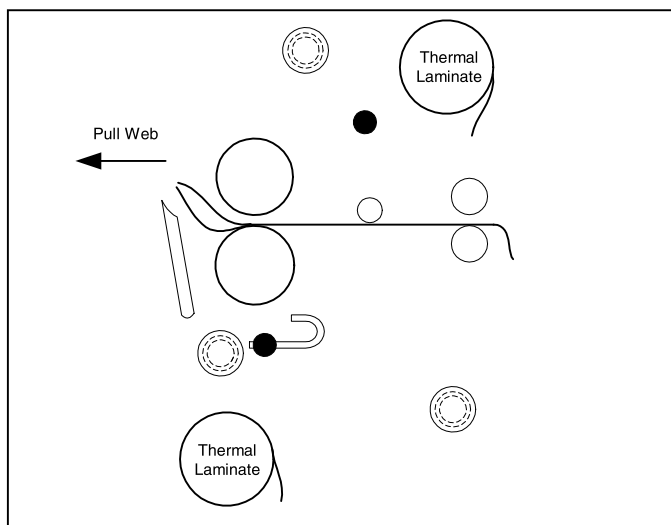

Fig. 36

TO UNWEB THE LAMINATOR

Unweb the laminator if you are changing film widths, cleaning the rollers or have finished using the machine for the day.

1. Using the rear slitter, cut the output from the web.
2. Press **FRONT ROLLER RELEASE** (⏪) and **REAR ROLLER RELEASE** (⏩).
3. Remove the safety shield and tilt the feed table.
4. Use the rear slitter to cut the exiting film from the web.
5. Cut remaining top and bottom film webs between supply rolls and heat rollers (Figure 35). PSA film, cut the release liner too. **Be careful not to cut any of the rollers!**
6. Carefully grab hold of the web (top and bottom film), from the front operating position and pull towards you (Figure 36).
7. Do not allow the adhesive side of the film to contact the heat or pull rollers.

CLEARING A FILM JAM (Wrap-up)

Film jams (wrap-ups) may occur if the film is loaded backwards or if the area at which film exits the equipment is blocked. The film, when jammed, wraps around the heat rollers during webbing if a threading card is not used or pull rollers during operation.

To clear a jam:

1. Immediately stop the laminator by pressing **STOP** (⏹).
2. Remove the safety shield and tilt the feed table.
3. Press and hold **REVERSE** (⏪) until the jam has cleared the heat rollers or pull rollers.
4. Press **FRONT ROLLER RELEASE** (⏪) and **REAR ROLLER RELEASE** (⏩).
5. Manually assist the material through the main rollers and/or pull rollers.
6. Once the jam has been cleared, press **FRONT ROLLER PRESS** (⏩) and **REAR ROLLER PRESS** (⏪).
7. You can now resume laminating.

PRELIMINARY
COPY

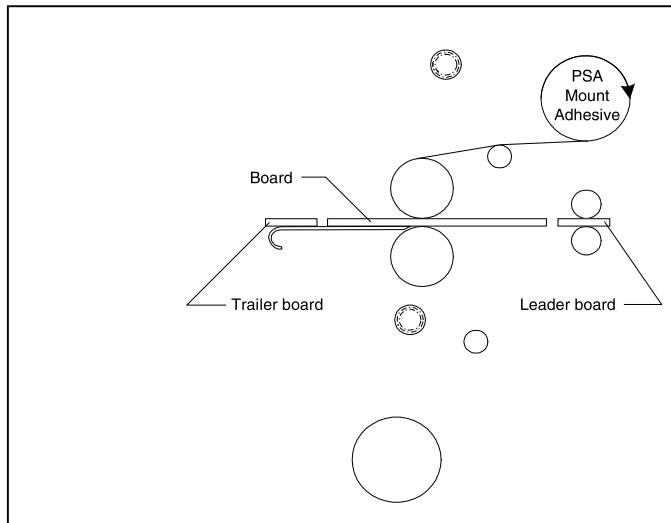

Fig. 37

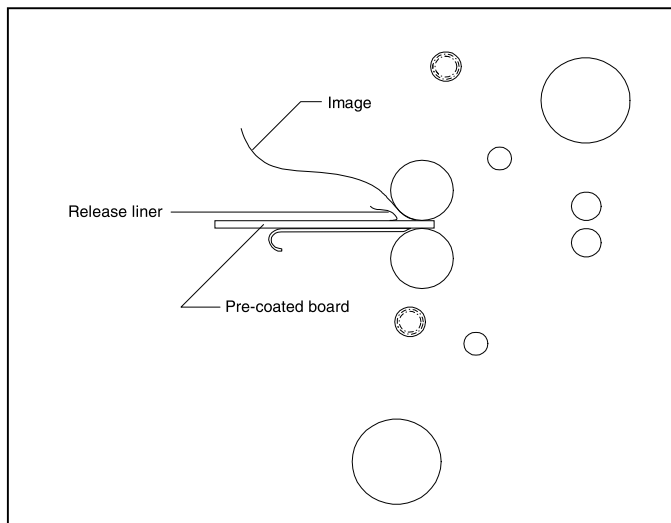

Fig. 38

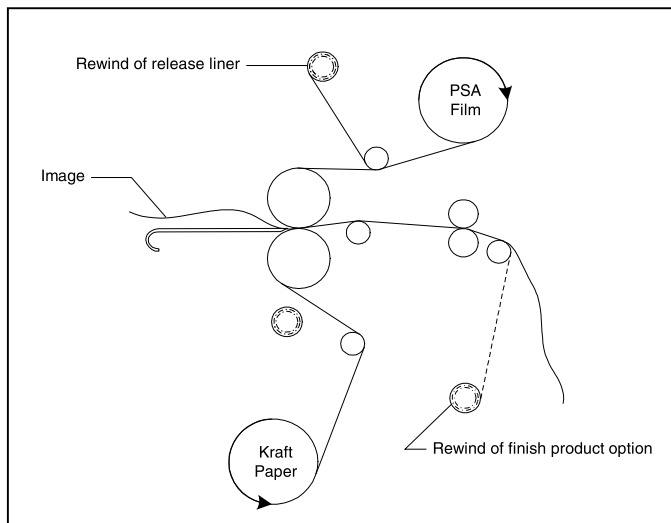

Fig. 39

TIPS FOR PRE COATING BOARDS (Figure 37)

1. Load the laminator as illustrated in Figure 37.
2. All of the tips for mounting will apply.
3. The width of the roll should not exceed the width of the board by more than 1/2 in. (1.3 cm).
4. Use a leader board to start the run and a trailer board to finish the run.
5. Using the pull rollers will allow you to leave gaps between boards.
6. If not using the pull rollers, have the boards nearby to butt end to end during feeding.

TIPS FOR MOUNTING PRE-COATED BOARDS (Figure 38)

1. Load the laminator as illustrated in Figure 38.
2. Ensure the correct JOB MODE (■) is selected.
3. Ensure the chill idler is removed, the rear slitter is to one side and the inline slitters are not obstructing the path of the boards.
4. Heat, 125 °F (52 °C), may assist the process and increase output quality.
5. Do not stop once you have started the mounting process through the machine.

TIPS FOR SINGLE SIDED LAMINATION (Figure 39)

1. Load the laminator as illustrated in Figure 39.
2. Use kraft paper for one-sided lamination whenever the items to be laminated are narrower than the film you are using.
3. If not using kraft paper, use a scrap piece to finish the run or you will have adhesive on your rollers.
4. Running the web over the chill idler may improve the flatness of the output.
5. A little heat, 125 °F (52 °C), may help eliminate silvering effects associated with PSA films.

PRELIMINARY
COPY

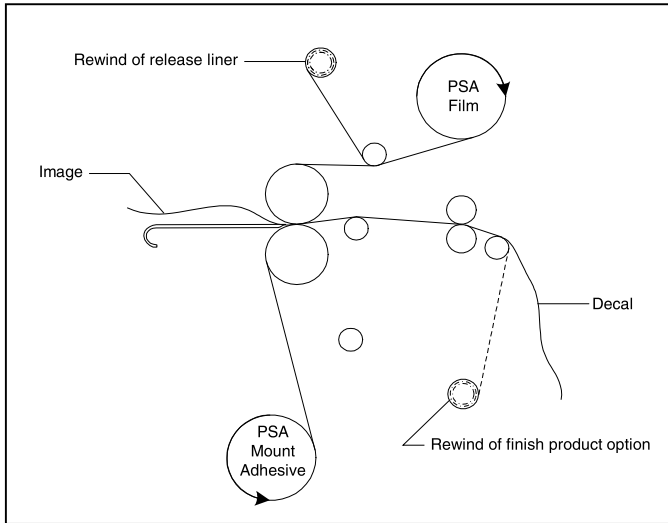

Fig. 40

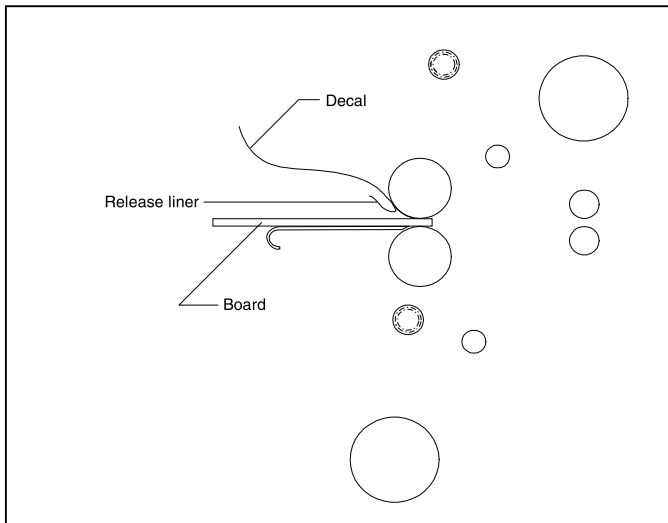

Fig. 41

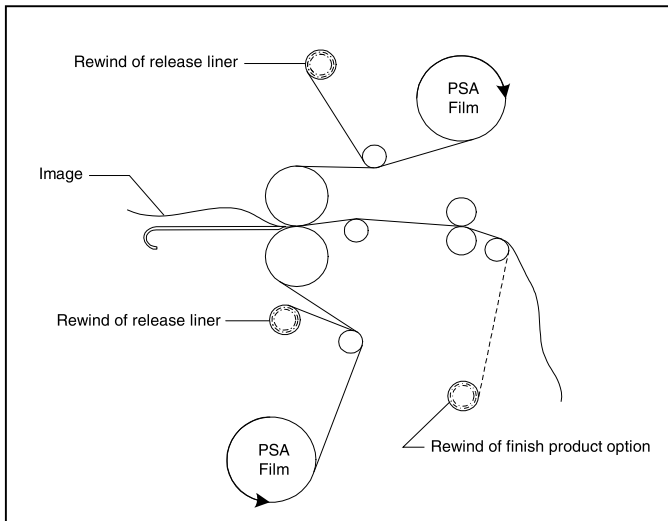

Fig. 42

TIPS FOR CREATING A DECAL (Figure 40)

1. Load the laminator as illustrated in Figure 40.
2. The over laminate may be PSA or thermal type.
3. If using thermal type, pay attention to the Poly-in/ Poly-out rule.
4. Run a test material prior to running the actual image to ensure flat output.
5. Use minimal brake tension to achieve quality output.
6. Do not web the PSA mount adhesive around the lower web idler.

TIPS FOR MOUNTING A DECAL (Figure 41)

1. Load the laminator as illustrated in Figure 41.
2. The image should not exceed the width of the board by more than 1 in. (2.54 cm) per side.
3. Tack about 1 in. (2.54 cm) of the leading edge of the decal to the leading edge of the board.
4. When tacking the leading edge, start in the center and work to the sides.
5. Use a board that exceeds the size of the decal if inexperienced in the mounting application.

TIPS FOR PSA ENCAPSULATION (Figure 42)

1. Load the laminator as illustrated in Figure 42.
2. Always use two rolls of the same width.
3. Use minimal brake tension to achieve flat output.
4. The separation of the laminate and the release liner should be maintained close to the heat rollers.
5. A little heat, 125 °F (52 °C), may help eliminate silvering effects associated with PSA films.

PRELIMINARY
COPY

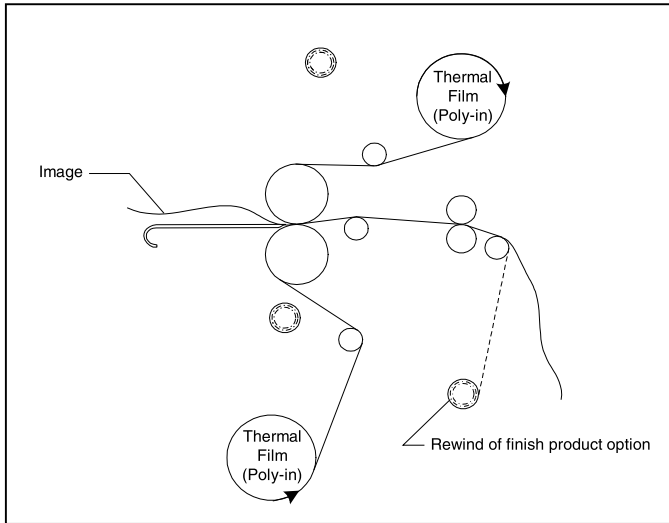

Fig. 43

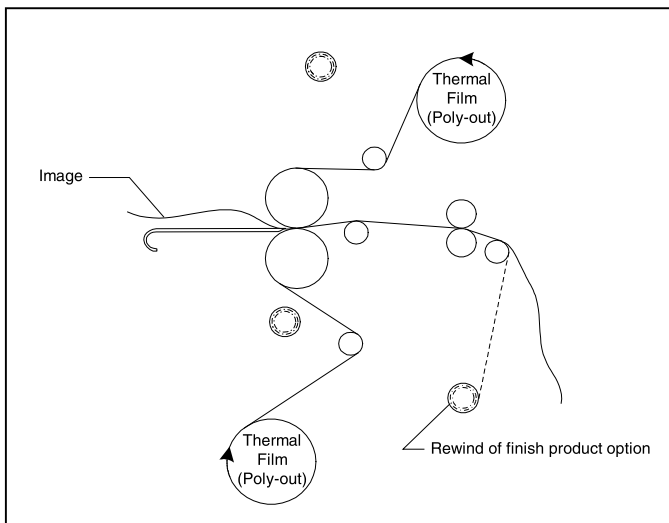

Fig. 44

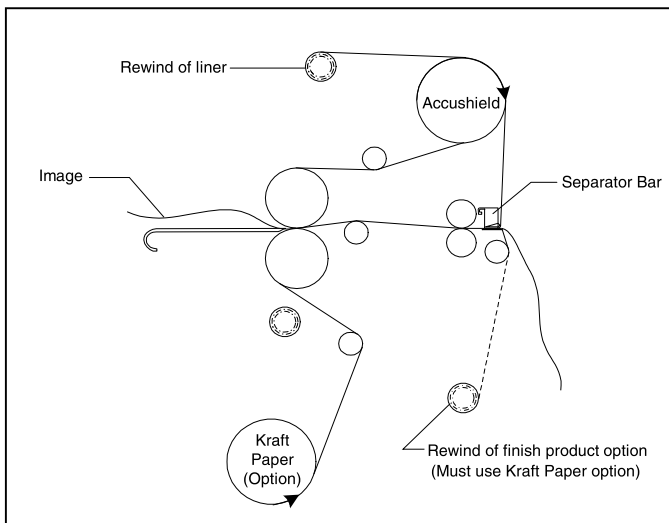

Fig. 45

TIPS FOR THERMAL ENCAPSULATION (Figure 43)

1. Load the laminator as illustrated in Figure 43 for Poly-in film.
2. Load the laminator as illustrated in Figure 44 for Poly-out film.
3. Always use two rolls of film the same width.
4. Use minimal brake tension to achieve flat output.
5. Increase speed gradually to maintain the activating temperature required for the laminate you are using.
6. Length and width of image, ink coverage and paper type may effect the temperature and speed recommended in the **SPEED/TEMPERATURE GUIDE**.

TIPS FOR ACCUSHIELD (Figure 45)

1. Load the laminator as illustrated in Figure 45.
2. You must have the Separator bar option to accurately run this material.
3. Use the Accushield job mode.
4. Liner rewind tension will be greater than normal operating standards.
5. Do not attempt to run this material greater than a speed setting of 4.
6. To prevent some adhesive adhering to the rollers, you may choose to use a roll of kraft paper for a carrier.

PRELIMINARY
COPY

SPEED/TEMPERATURE GUIDE

(Figure 46 A & B)

This is only a general reference guide. Different settings may be suitable as the warm up time, lamination time and materials change.

Factors that may effect the speed and tempeprature parameters;

1. Image length
2. Image width
3. Ink coverage
4. Paper type
5. Laminate thickness
6. Operating enviroment
7. Condition of the rollers
8. Line voltage (effects heaters)
9. Using vacuum and/ or cooling features.

12/02 You may have to adjust temperature or speed depending on stock finish, thickness and ink coverage.

*Turn heat off when not in use.

Stock	Film Gauge	Nap-Lam II		Nap-Lam I		*Vinyl		Premium		Hi-Tac	
		Settings		Settings		Settings		Settings		Settings	
		Temp (F)	Speed	Temp (F)	Speed	Temp (F)	Speed	Temp (F)	Speed	Temp (F)	Speed
20# Bond	mil										
	1.5	248	8	290	7					255	8
	3	239	6	270	5			225	4		
	5	230	5	250	3	230	5	220	3		
	10	221	3					210	3		
80# Bond	1.5	248	6	295	7					255	6
	3	239	5	275	5			230	4		
	5	230	3	250	2	230	3	225	3		
	10	221	2					215	3		
10 Pt. Board	1.5	248	5	300	6					255	4
	3	239	4	275	4			235	4		
	5	230	2	250	2	230	2	230	3		
	10	221	2					220	2		

Fig. 46 A

PRELIMINARY COPY

Stock	Film Gauge	Nap-Lam II		Nap-Lam I		*Vinyl		Premium		Hi-Tac	
		Settings		Settings		Settings		Settings		Settings	
		Temp (C)	Speed	Temp (C)	Speed	Temp (C)	Speed	Temp (C)	Speed	Temp (C)	Speed
20# Bond	38	120	8	143	7					123	8
	75	115	6	132	5			107	4		
	125	110	5	121	3	110	5	104	3		
	250	105	3					99	3		
80# Bond	38	120	6	146	7					123	6
	75	115	5	135	5			110	4		
	125	110	3	121	2	110	3	107	3		
	250	105	2					107	3		
10 Pt. Board	38	120	5	149	6					123	4
	75	115	4	135	4			112	4		
	125	110	2	121	2	110	2	110	3		
	250	105	2					104	2		

Fig. 46 B

THE ART OF LAMINATION

BASIC RULES

Do not attempt to laminate abrasive or metal objects such as staples, paper clips and glitter, as they may damage the heat or pull rollers.

Do not force items into the nip area of the heat rollers. An item that is not easily drawn into the laminator by the heat rollers is probably too thick to laminate.

Wrinkles may result if an attempt is made to reposition an item once it has been grasped by the heat rollers.

Do not stop the laminator before an item has completely exited the pull rollers.

Even a momentary stop will cause a mark (heat line) on the laminated item.

Good, consistent lamination is a result of combining proper heat, tension and dwell time. Dwell time is controlled by the speed of the motor and is defined as the amount of time the material to be laminated is compressed between the heat rollers.

As a general rule, thicker items and film need to run at slower speeds because they extract more heat from the rollers at a quicker rate. Setting the speed control at slower settings gives the laminator longer dwell time thus allowing proper lamination of thick items. Thinner items, such as standard copier paper (20 lb. bond) and tissue paper, extract less heat from the rollers and can be run at faster speeds.

FILM TENSION

Proper film tension, known as brake tension, is the minimum amount required to eliminate wrinkles in the finished item. The film should be taut. A properly adjusted roll of film should not require excessive force to turn by hand.

Film tension should be enough to introduce a minor amount of drag as the film unrolls. Insufficient tension causes wrinkles, while too much tension causes stretching (necking). Uneven tension between the top and bottom rolls create curl. Too much upper tension creates upward curl while too much bottom tension causes downward curl.

The pull roller clutch is set at the factory. Periodic adjustments may be necessary if after adjusting unwind and rewind brake tensions do not improve your output quality.

PRELIMINARY
COPY

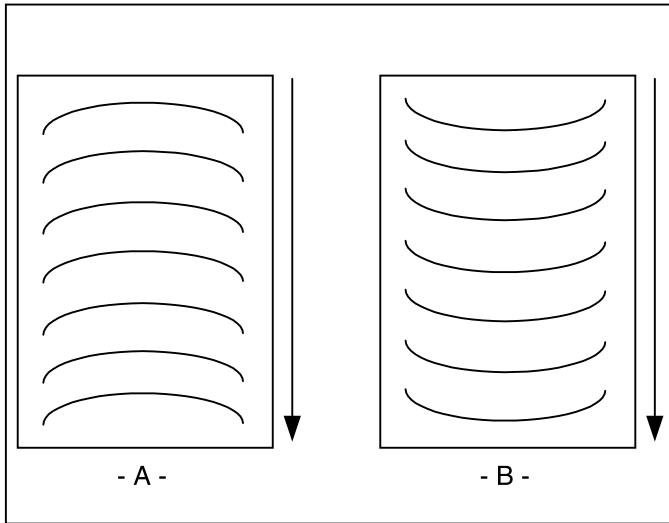

Fig. 47

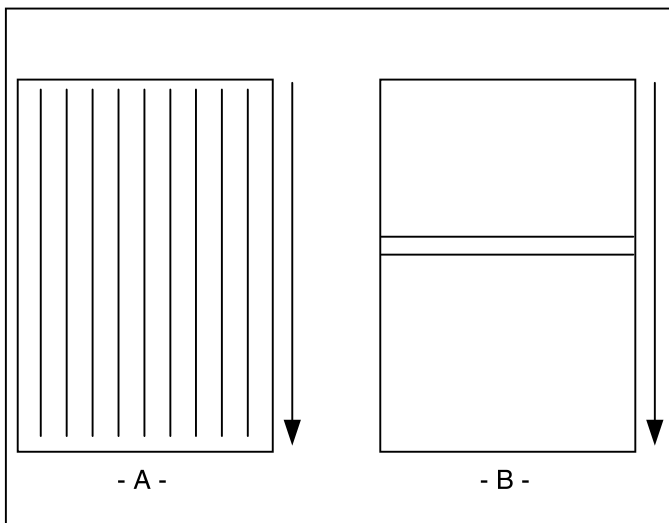

Fig. 48

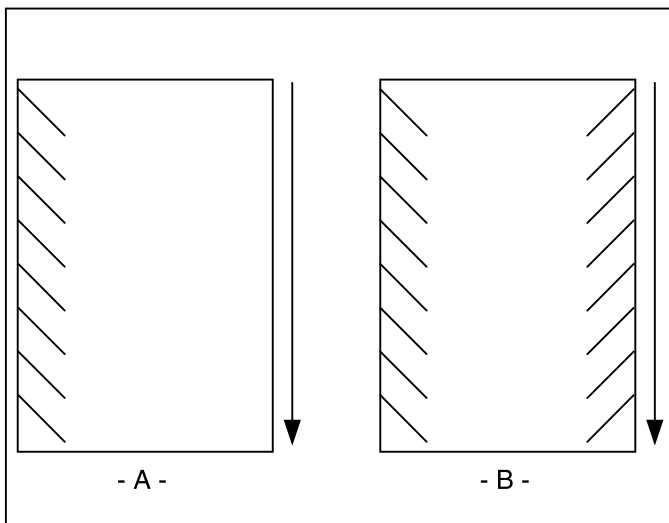

Fig. 49

HEAT

The “**WAIT (Too COLD)**” indicator may appear if the speed is set too fast for the material being laminated. Either lower the speed setting or press **STOP** and wait until the “**READY**” indicator appears.

Operation of the laminator for more than thirty minutes at a time may necessitate a lower speed setting. It is recommended that, during periods of long runs, the items being laminated are alternated between thick and thin. **Do not combine thick and thin items at the same time, as this will result in a poor edge seal around the thinner material.** If you are unsure that the laminator is set at the proper speed for the item to be laminated, run a test piece (scrap) of the same or similar material through the laminator. This procedure is recommended because rotating the heat roller prior to lamination will more evenly distribute the heat. Make speed adjustments if necessary.

OUTPUT

1. “D” waves in the image (Figure 47 A).

- Check paper tension.
- Paper may be damp or not dry.

2. “D” waves in the laminate (Figure 47 B).

- Main air supply setting.
- Check heat roller nip calibration.
- Check pull roller nip calibration.

3. Straight waves in output (Figure 48 A).

- Check operational settings for materials being used.

4. Indent waves in output after pull rollers (Figure 48 B).

- Insufficient cooling time.
- Output was handled prior to cooling.
- Use cooling feature if not on.
- Machine was stopped on print.

5. Angled waves in the output (Figure 49 A & B).

- Main air supply setting
- Check heat roller nip calibration
- Check pull roller nip calibration
- Check for even paper tension (Figure 49 A only)

PRELIMINARY
COPY

MAINTENANCE

CARING FOR THE GBC ORCA 64 LAMINATOR

GBC offers Cleaning kits as well as Extended Maintenance Agreements.

Contact your local GBC Service Representative or your dealer/distributor for additional information.

The only maintenance required by the operator is to periodically clean the heat rollers and schedule semi annual maintenance checks.

The following procedure will help keep the heat rollers free of adhesive that has been deposited along the edge of the laminating film. Proper alignment of the rolls of film reduces the amount of "squeeze out".



WARNING: Do not attempt to laminate adhesives marked "Flammable".

- Do not laminate glitter and/ or metallic items. Damage to the rollers may result.



WARNING: Do not apply any cleaning fluids or solvents to the rollers. Some solvents and fluids could ignite on heated rollers.

- Never clean rollers with sharp or pointed objects.
- Hardened adhesive deposits on the rollers can cause damage to the rollers. Rotate the rollers at the lowest speed setting on the control panel.



CAUTION: THE FOLLOWING PROCEDURE IS PERFORMED WHILE THE LAMINATOR IS HOT. USE EXTREME CAUTION.

1. Remove the film from the laminator following the procedure outlined in steps 1 through 6 of the section entitled **TO UNWEB THE LAMINATOR**.
2. Preheat the laminator until the "READY" indicator appears.
3. Remove the safety shield and tilt the feed table.
4. Rub the top and bottom heat rollers with a 3M™ Scotch-Brite™ pad . **DO NOT USE METAL SCOURING PADS!**
5. Use the footswitch to rotate the lower heat/pull roller to an unclean portion. The upper heat/ pull roller are free spinning. Continue this process until the complete surface of both rollers are clean.
6. Refer to the beginning of the section entitled **OPERATING INSTRUCTIONS** to web your laminator.

***NOTE:** Do not use metal scouring pads to clean the rollers.

PRELIMINARY
COPY

TROUBLE-SHOOTING GUIDE

SYMPTOM	POSSIBLE CAUSE	CORRECTIVE ACTION
<ul style="list-style-type: none"> The control panel display does not illuminate when POWER ON/OFF is in the ON, marked "I", position. 	Laminator not connected to electrical supply.	Insert attachment plug into receptacle.
<ul style="list-style-type: none"> Heat rollers do not turn when I press the START (↔) button. 	Safety shield is not properly installed. Feed table interlock pin not in place. E-STOP is engaged	Remove safety shield and properly replace it. Slide interlock lever all the way into the left and right side frame. Pull out on the E-STOP push button.
<ul style="list-style-type: none"> Heat rollers only turn in "Footswitch Enabled" mode. 	Safety shield is not properly installed. Feed table interlock pin not in place.	Remove safety shield and properly replace it. Slide interlock lever all the way into the left and right side frame.
<ul style="list-style-type: none"> Laminated items exhibit curling. 	Tension between the top and bottom film roll is unequal. Tension on top or bottom roll of film is too loose. Speed setting too slow. Bottom film roll may be improperly loaded. Chill idler not installed	Adjust tension per section FILM TENSION . Adjust tension per section FILM TENSION . Slightly speed up the laminator. Make sure bottom roll of film is around idler bar and the it is in the normal operating position. Install the chill idler.
<ul style="list-style-type: none"> Adhesive deposited on heat rollers. 	Top and bottom film webs not aligned. Laminate improperly loaded.	Release heat and pull roller pressure, align the rolls of film. Adhesive (matte) side of laminate film may be against the heat rollers. Unweb and reload the film properly.
<ul style="list-style-type: none"> Unsatisfactory adhesion of laminate. 	Speed setting too fast for type of material being laminated. Insufficient heat. Laminate improperly loaded. Heat rollers require cleaning. Laminated item unsuitable for adhesion.	Lower speed setting by pressing SLOW button to slower speed Wait for " READY " indicator to appear in the control panel display. Adhesive side of film must be facing away from the heat rollers. Bottom roll of film not threaded behind the idle bar. Clean heat rollers per procedure in section CARING FOR THE GBC ORCA 64 LAMINATOR . Item may be dirty or may have non-porous surface that is extremely difficult to laminate.
<ul style="list-style-type: none"> Waves in my output 	See sub section OUTPUT . Nips may be out of calibration.	Under section titled THE ART OF LAMINATION . Place a service call for calibration check.

SERVICE AGREEMENT

GBC's Equipment Maintenance Agreement will insure the quality performance and long life built into your laminator.

A service charge for travel time, labor and parts may be incurred for each out of warranty service call. GBC's Equipment Maintenance Agreement decreases these expenses and protects your valuable investment. GBC offers several types of agreements to suit your needs and budget. To contact GBC write to:

GBC NATIONAL SERVICE
 ONE GBC PLAZA
 NORTHBROOK, IL 60062 U.S.A.
 1.847.272.3700

IN CANADA:

GBC NATIONAL SERVICE
 49 RAILSIDE ROAD
 DON MILLS, ONTARIO
 M3A 1B3

Part Number 930-087 Revision -

PRELIMINARY
COPY

PRELIMINARY
COPY

PRELIMINARY
COPY

PRELIMINARY
COPY

PRELIMINARY
COPY

RECOMMENDED SPARES

GBC Recommends these spare items to reduce your down time in the event of a problem with your laminator. By having these recommended items on hand, your machine can be up and running usually on the same day it goes down which enables you to produce quality lamination that much sooner. You may choose to all the recommended items or condense the list to fit your comfort and needs.

<u>Part number</u>	<u>Item</u>	<u>Qty</u>
609060110	DC Geared Motor	1
706011163	PCB, Interrupter	1
704090253	E-STOP Switch	1
703070283	Air Filter Assembly	1
607050121	Heat Roller, Upper	1
607050119	Heat Roller, Lower	1
607050123	Pull Roller	2
704090419	Micro Switch, Table	1
609040302	Vacuum Fan	2
705200201	Infrared Sensor	1
706011196	PCB, Tension Adjust	1
703070281	Main Cylinder	1
703070282	Pull Cylinder	1
703070284	Solenoid Valve	1
609050311	Synchronous Motor	2
601310508	Micro Switch, Shield	1
706011192	PCB, Control Panel	1
706011193	PCB, Motor Drive	1
706011195	PCB, Vacuum Drive	1
706011194	PCB, Cooling Drive	1
706011741	PCB, EMO Control	1
706011740	PCB, Main Control	1
706011198	PCB, Power Supply	1
706025091	Heater Assembly	2
810600026	Heater Support Wire	2
8040201	In-Line Slitter Blade	2

PRELIMINARY
COPY

ILLUSTRATED PARTS



General Binding Corporation

One GBC Plaza

Northbrook, IL 60062-4195
