

Martin Yale BCS412 12up Business Card Slitter - Score and Perf

Instruction Manual



Provided by

MyBinding.com
When Image Matters.

Call Us at 1-800-944-4573

intimus®

A MARTIN YALE BRAND

Operating Instructions SP100, BCS400 series

BCS400 Series



SP100



1.0 Introduction

Thank you for your purchase of the **intimus®** line of Business Card Slitters or Scoring/Perforating machines. With proper maintenance your unit will provide you with years of service. Upon receiving the machine verify that there are no signs of shipping damage on the exterior. If you feel the product may have been damaged in transit, contact the appropriate freight carrier immediately, then contact technical support at Martin Yale Industries, Inc. at 260-563-0641.

Upon opening the machine, verify that you have the following components.

2.0 Inventory of Contents

SP100

SP100 Unit
Catch Tray W-ODT0021
Paper Support W-ODT1124
3/32" T- Handle Allen M-S012012
Operating Instructions
8.5" Top Plate W-ODT0100
11.0" Top Plate W-ODT0200

BCS400 Series

BCS400 Series Unit
Receiver Tray W-ODT0024
Receiver Base Form W-ODT0023
Paper Support W-ODT1124
T- Handle 3/32" Allen M-S012012
10 - Up Catch Tray W-ODT0021
12 - Up Catch Tray W-ODT0020
Operating Instructions
8.5" Top Plate W-ODT0100
11.0" Top Plate W-ODT0200

Model:
Serial No:
Manuf. Date:

3.0 Specifications

- > Accessory shafts can be easily disassembled for addition of optional components.
- > Units will handle 24# bond to 100# cover stock.
- > Min. Sheet Size 4 1/8" X 3 1/2"
- > Max. Sheet Size 8 1/2" X 11"
- > Speed: BCS412: 300 finished cards per minute.
BCS410: 375 finished cards per minute.
SP100: 1400 8 1/2" X 11" sheets per hour.

SHIPPING WEIGHTS

-MODEL SP100 23 lb#
-MODELS 410&412 44 lb#

4.0 Set up from carton to table

Caution: The unit contains rotating blades and other dangerous items. Do not remove any safety covers from the machine. Be aware that loose jewelry, long hair and loose fitting clothes should be kept away from the unit.

1. Set the machine on a tabletop. Verify the power switch is set to "0" (off position).
2. Look in each feed shelf of your unit, and verify that the tips of the sheet retarder are not in contact with the feed wheels. These are preset at the factory and should not need to be adjusted. **Note: If the machine is operated with the retarder in contact with the feed wheels the wheels could be damaged.**

Make sure that the sheet retarder tips are not touching the feed wheel in each shelf when the machine is turned on.

Retarder is factory set to .012 gap and should not need to be adjusted for typical 65# stock.

Retarder

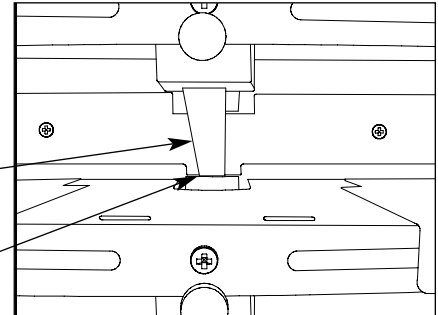

Figure 1

- 2a. Remove taped accessories from the exit tray shelves. These are used as paper weights on top of the stack to insure accurate tracking of curled stocks, or for stocks that require additional control for accurate feeding and registration. See Figure 2.

Make sure that the stack weights are removed from the feed bins before the machine is run for the first time.



Figure 2

3. Turn rocker switch to "1" . The unit should begin running. If there is no power, try the following:
 - 3a. Check the electrical outlet to verify function. A good way to do this is to plug in another device that you know works.
 - 3b. If still no power, check that circuit breaker has not tripped. Find source of machine bind and correct. Allow machine to cool and push breaker in to reset.
 - 3c. Call the technical support division at Martin Yale Industries, Inc. at 260-563-0641.

4.1 Tray/ Paper Support Installation

Depending on the model, install the paper support and collection bins onto the machine. A paper support is utilized on the in feed of any bin where the sheets overhang the edge of the feed shelf. The paper support is installed by inserting the tabs into the slots on the front of the feed shelves as shown in Figure 3. Also, for units that make business cards, the bottom shelf will be where the first pass is made and the shelf above it will be where the finished product is created. **NOTE: On the 400 series the bottom stacking tray and paper support can be moved to the top shelf for stacking of scored or perforated stock.** See Figure 4 for correct location of collection trays on the 400 series business card slitters.

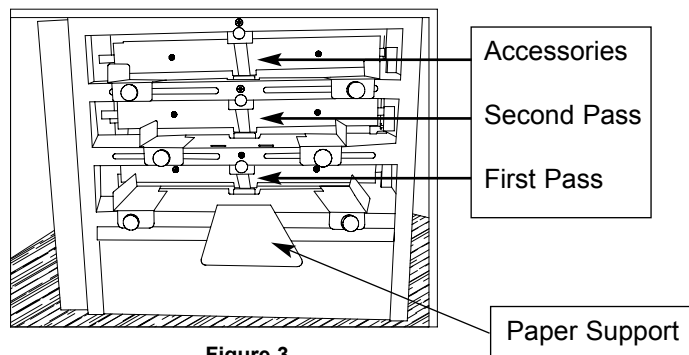

Figure 3

Collection bin for finished cards goes on middle shelf; large collection tray goes on top or bottom.

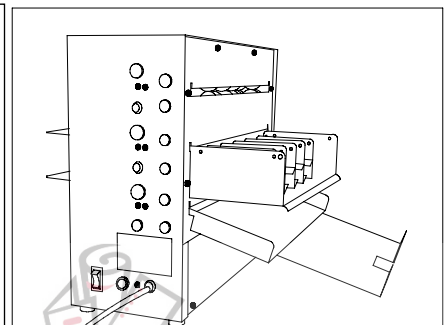

Figure 4

5.0 Setting Registration

Note: The registration is preset at the factory and should not be adjusted unless it is determined that it is not correct for the stock being used.

Perform the following steps in order to achieve accurate registration.

1. Loosen the thumb knobs on the paper guides for the appropriate shelf (see Figure 5).
2. Raise retarder up using the thumb knob on the side of the machine (rotate counter-clockwise) until stock will easily slide under retarder (Figure 7, Below.)
3. Align register marks on layout sheets with the cutter blade edges (Figure 8).
4. Position paper guides so that side-to-side movement will be no more than 1/32". NOTE: The guides should not pinch the stock. Inaccurate feeding could result if too tight (Figure 9).
5. Feed single sheets to test for accuracy. Readjust paper guides as necessary.

NOTE: You may want to use unprinted stock for initial start up to remove residual oil from cutting blades.

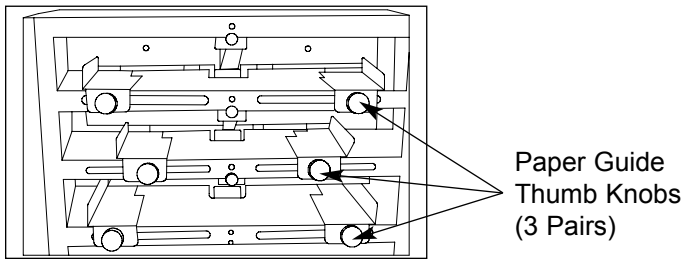

Figure 5

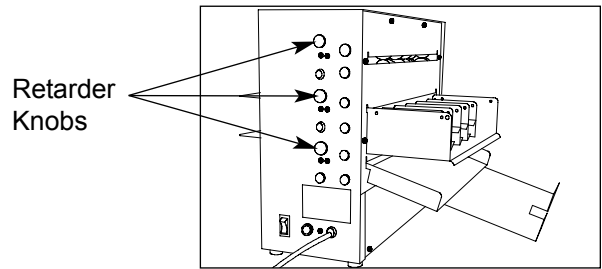

Figure 6

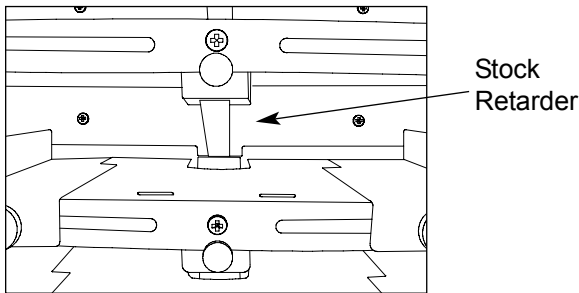

Figure 7

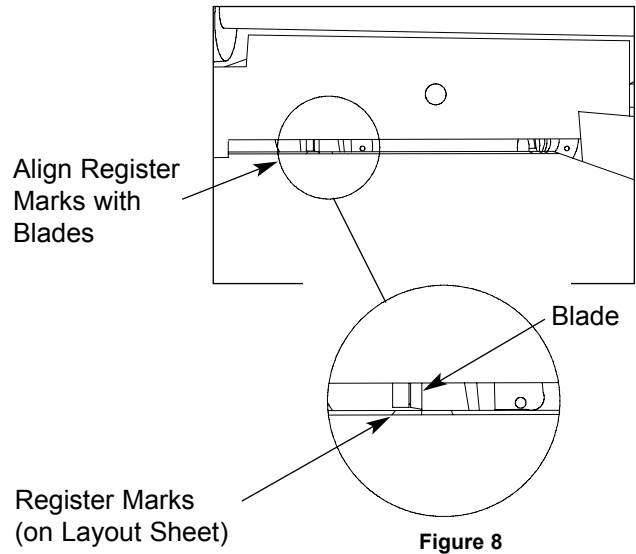

Figure 8

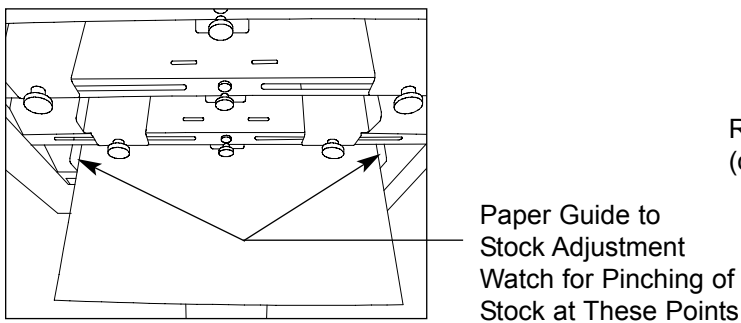

Figure 9

Verifying a square cut:

To verify that the finished product is square, take a stack of business cards and divide in half. Flip $\frac{1}{2}$ over and recombine. All edges should align evenly. If edges do not align, the stock is skewing. See skewing section under 7.0 Troubleshooting.

5.1 Proper Feeding

NOTE: The feed is preset for 65# stock and typically does not require readjustment. Registration should be set before setting the retarder for single sheet feeding.

Follow these steps:

1. Using the adjustment knob on the front of the feed shelf, position feed pressure arm so that it is just above the feed wheel. Make sure there is no contact. (Figure 10).

Pressure arm should rest just out of contact with the feed wheel.

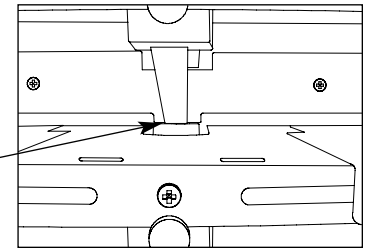

Figure 10

2. Using the adjustment knob on side of feed shelf, raise retarder off feed wheel. Insert one piece of stock to be ran in between the retarder and feed wheel so that sheet passes freely. Lower retarder so that there is a slight drag on the stock as it is pulled out.
3. Place a neat stack of three sheets into the unit and test. Readjust as necessary until one sheet feeds steadily.

Feeding Thermographic or severely curled stock:

In some applications a hesitant feed can occur if the raise of the lettering prevents the sheet retarder from functioning normally. This can also occur with heavier stocks should they develop a curl when printed.

Should this become an issue, the following steps can be performed:

1. Run stock through image side down.
2. Apply some weight to the stock for a period of time before it is to be run.
3. Use the 8.5" and 11.0" weights on top of the stack.

Should stock still have feed issues call technical support at Martin Yale Industries, Inc. at 260-563-0641.

Obtaining Service

Should your machine need to be professionally serviced, Martin Yale Industries, Inc. can refer you to the nearest Factory Authorized Technician. Contact us at the phone number given above.

6.0 Accessory Function

Factory standard accessories include scoring wheels and perforator wheels. Each component uses its own cutting hub as an assembly. The components cannot be separated.

To engage the scoring roller, follow the instructions below:

1. Loosen the 3/32" Allen set screw in the lower back up hub.
2. Slide the scoring roller and hub to the appropriate location.
3. Retighten the setscrew in the back up hub.

NOTE: The scoring roller does not contain a setscrew. This component should be free spinning.

To engage the perforator wheel, follow the instructions below:

1. Loosen the 3/32" Allen set screw in the perforating wheel and in the backup hub.
2. Slide components to the appropriate location. Retighten both setscrews.

NOTE: THE BACKUP HUBS ARE NOT INTENDED TO BE SEPARATED FROM THEIR UPPER COUNTER PART. DO NOT ATTEMPT TO SEPARATE THESE ITEMS.

NOTE: Positioning of the feed rollers to the scoring/perforating blade should be located at the left edge and right edge of stock being used.

NOTE: OVERTIGHTENING OF SET SCREWS CAN CAUSE STRIPPING. WHEN TIGHTENING ACCESSORIES, SCREWS SHOULD BE APPLIED 1/8-1/16 OF A TURN PAST SNUG.

7.0 Troubleshooting

Multiple Sheet Feeding:

1. Set feed system per Section 5.1.
2. If stock is glossy the feed wheels of the machine may have grip issues. This is a common issue with friction - fed units. If one side is not glossy, run through with glossy side facing up.

Inaccurate Registration:

1. Set registration on unit per Section 5.0.
2. Double-check the layout to make sure that the register marks are being utilized in the proper manner.
3. Verify that locking knobs in the paper guides are tight. NOTE: DO NOT OVERTIGHTEN LOCKING KNOBS.
4. Check o-rings on the unit for signs of wear and tear. Clean paper dust off component.
5. Check the upper extreme left O-ring and the extreme lower right O-ring. Verify that the document is going under these on both sides. Readjust as necessary. If the document does not go under these on both sides it will cause the document to skew to one side.

Stacking Issues:

If business cards do not properly fall into slots:

1. Slide the collection tray as the machine runs to fine - tune positioning.
2. Make sure collection trays are not obstructed. They should hang freely from the exit side of the unit.

Scoring / Perforating Issues:

Scoring roller cutting stock:

The solution to this is to humidify your stock. Typically only very dry material will do this.

Poor perforation or score:

1. Check the nearness of the guide roller to the score or perforation wheel. If possible, position for better function to the extreme edges of the stock.
2. Verify that the set screws in the accessories have been tightened (scoring roller does not use a setscrew).

Skewing:

1. Most often occurs during the second cut (2" width) on business cards slitters (does not apply to the SP100). Check that paper guides are properly adjusted to give minimal side clearance on material and still allow stock to slide freely.
2. In the event the machine is properly set and a slight skewing may still occur, loosen the setscrew (A) in both of the collars with O-rings and slide collars inward (B) until slight resistance is felt. Do not push collar into slitter blade (C), as this will affect slitting quality. Retighten setscrews (A) after relocation and before operation. See diagram at right.

Moving O-ring collars usually requires some amount of trial and error. It should only be attempted after all the above recommendations have been exhausted.

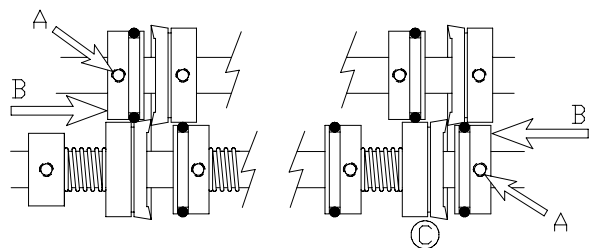

7.1 Maintenance

Proper maintenance of your unit will prevent most situations that cause damage. Follow the steps below to maintain the unit.

1. Once every 60 days, clean all paper dust from the unit.
2. Once every 90 days, check the Phillips head screws in each sheet retarder and make sure they are tight.
3. Periodically, check the power cord of the machine for frays and pinches. Replace cord should any damage be found.
4. As needed, clean feed wheels on the unit with mild cleaner and a Scotch-Brite pad.
5. Periodically clean the O-rings on the cutter shafts with a damp, soft cloth.
6. In the event of blade removal during the life of the machine, a diagram of blade placement has been included for reassembly purposes. See Figure next page. **CAUTION: Blade spacing and tension is extremely critical to the operation of any business card slitter. Only a qualified service technician should attempt blade removal/replacement.**

BCS 410/412, SP100 Parts List

Item	Part No.	Description	Item	Part No.	Description
1.	W-ODT0019	Adjustment Block	31.	W-ODT0023	Receiver Base Form
2.	M-S031092	Spring	32.	W-ODT0021	10 Up Catch Tray
3.	W-ODT0015	Sheet Separator	33.	W-ODT0020	12 Up Catch Tray
4.	W-IDT1119	Feed Bracket	34.	W-ODT0001	Housing Assembly
5.	M-S032046	Thumb Screw Knob	37.	W-ODT0004	Housing Assembly
6.	M-S019033	Stand Off	38.	W-ODT0017	Slitter Shaft
7.	W-ODT1123	Pressure Finger	39.	M-S014029	3/8 Clip Bearing
8.	W-ODT0016	Adjust Bar	40.	W-ODT0115	Tension Collar
9.	W-ODT1124	Paper Support	41.	M-ODT1105	Blade
10.	M-S032007	Knob	42.	M-S031091	Blade Spring
11.	W-ODT0014	Right Hand Guide	43.	M-O200134	1/2" Set Collar
12.	W-ODT0013	Left Hand Guide	44.	M-S014030	1/2 Clip Bearing
13.	W-ODT0010	Drive Cover	45.	W-ADT1114	Feed Roll Assembly
15.	W-ODT0012	Drive Cover	46.	M-S014031	5/8 Clip Bearing
16.	M-S019033	Stand Off	47.	M-O003076	Accessory Guide Roller
17.	M-S022132	15T Pulley	48.	M-O003082	Score Roller Back Up
18.	M-S022130	10T Pulley	49.	W-ODT1109	Groove Guide Roller
19.	M-S022015	12T Pulley	50.	W-ODT0018	Perf - Score Shaft
20.	M-S022131	14T Pulley	51.	M-O003080	Accessory Rubber
21.	M-S63751563	Pulley 20XL	52.	M-O003079	Accessory Bushing
22.	M-S025054	125T Double Sided Belt	53.	M-O003083	Scoring Roller
24.	M-S025052	65T Double Sided Belt	54.	WRA03085D	Perf Roller
25.	M-S030045	Bumpers	55.	W-ODT0107	Spacer
26.	M-S021073	Motor	56.	M-S63751634	24T Pulley
27.	W-ODT0007	Rear Cover	57.	W-ODT0022	Base
29.	W-ODT0009	Rear Cover	58.	W-ODT0025	End Plate
30.	W-ODT0024	Receiver Tray			

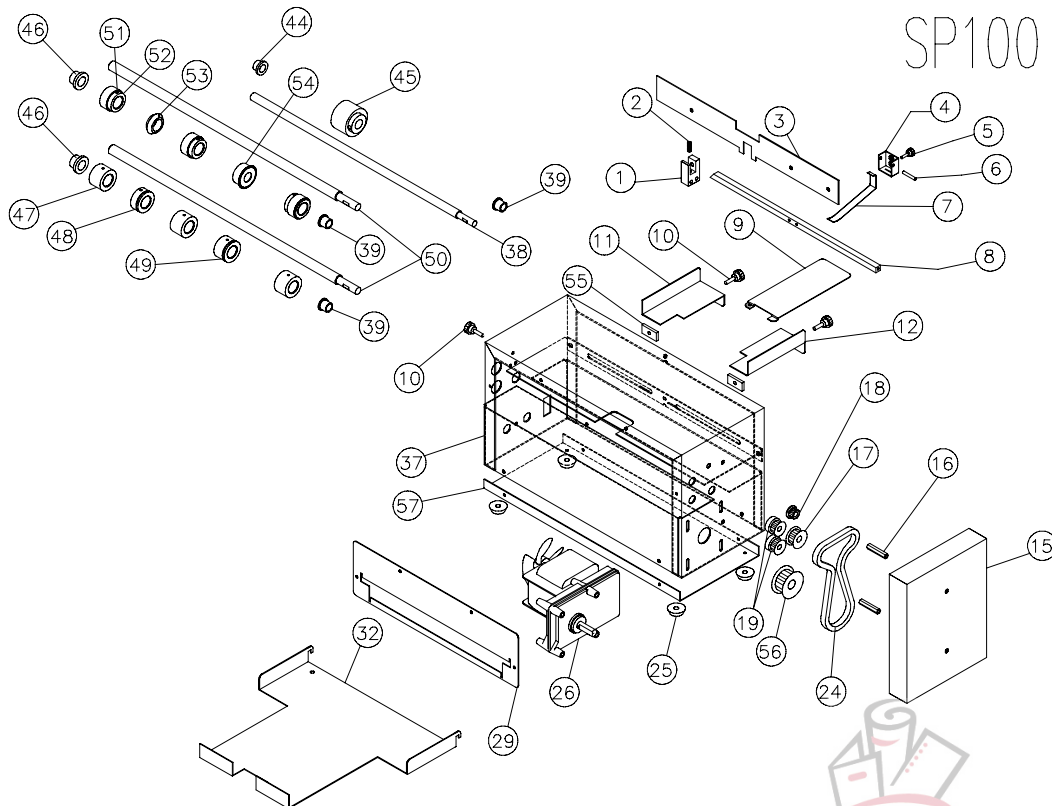

410/412

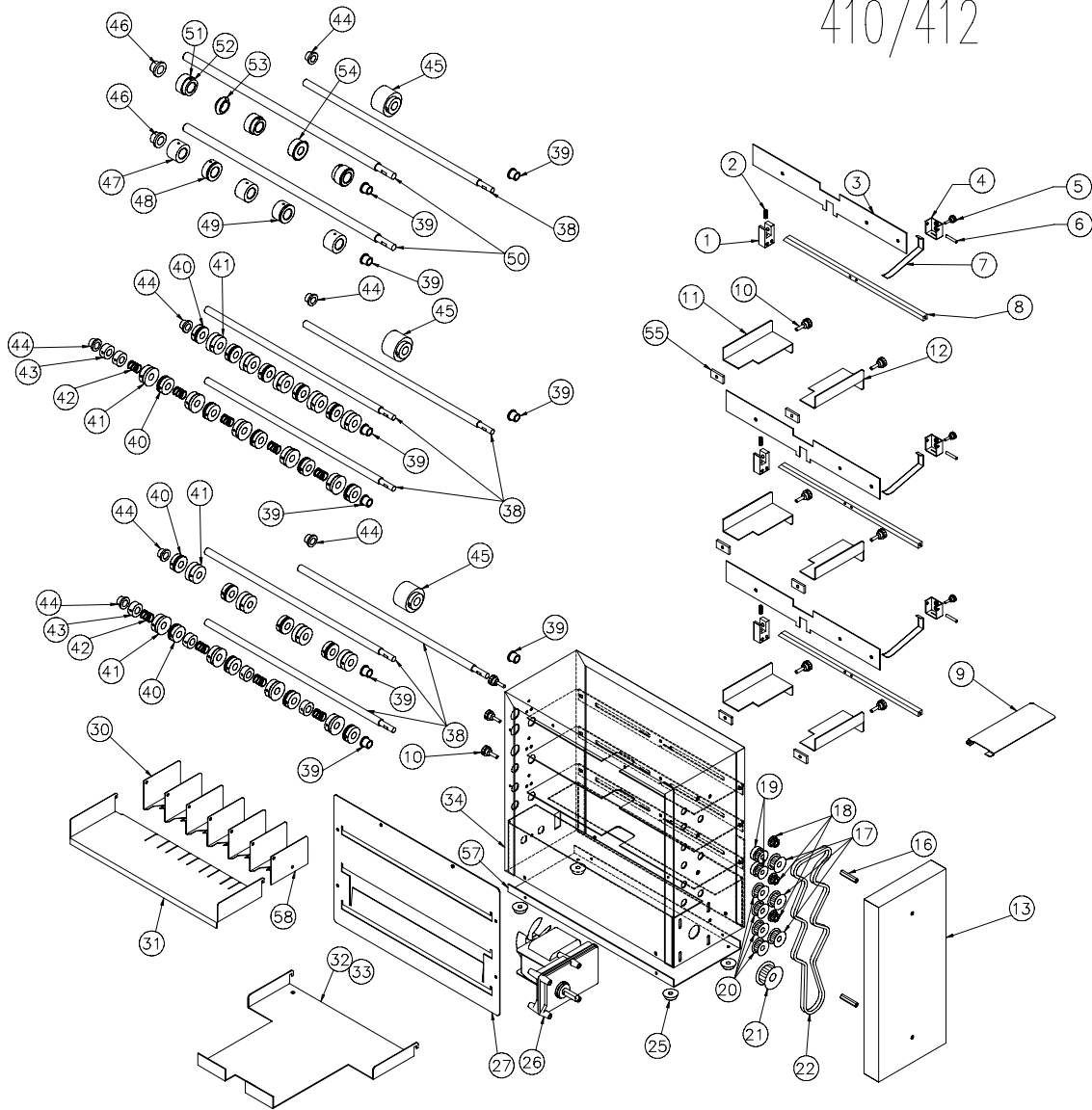

BCS 410/412, SP100 Wiring Diagram

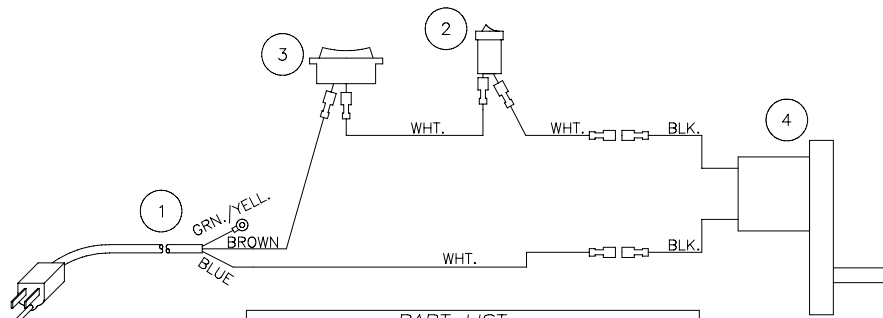

PART LIST			
FIG.	PART No.	DESCRIPTION	QTY.
①	M-S037020	110 VOLT CORD	1
②	M-S045237	1 AMP BCS CIR. BREAKER	1
③	M-S033053	SWITCH ON/OFF	1
④	M-S021073	110 V.A.C. BCS MOTOR	1

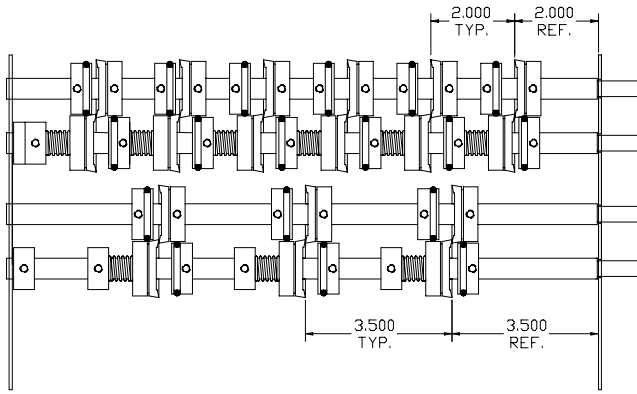

10 UP FORMAT

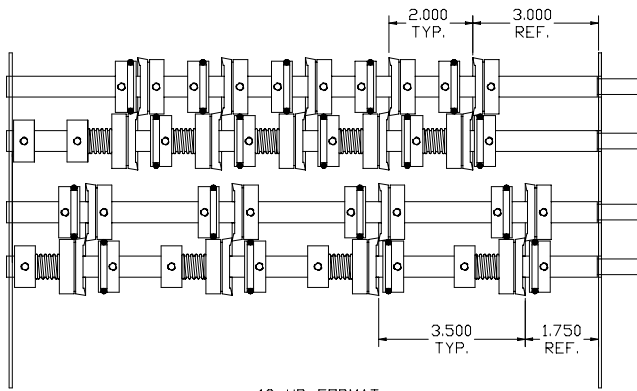

12 UP FORMAT

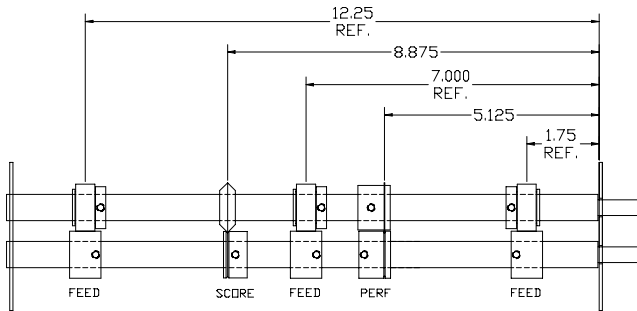

PERF/SCORE ACCESSORIES

10 UP FORMAT

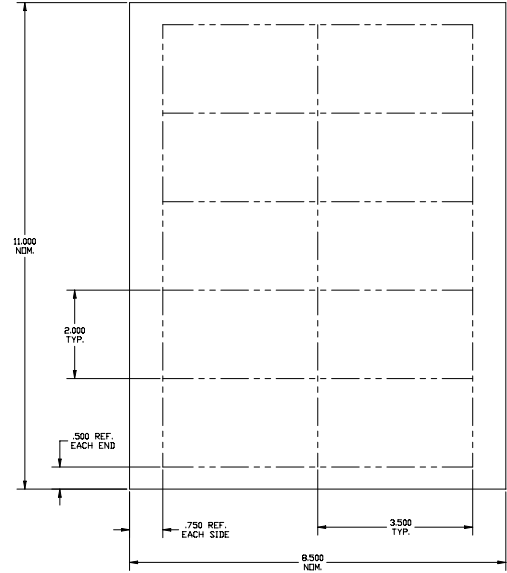

12 UP FORMAT

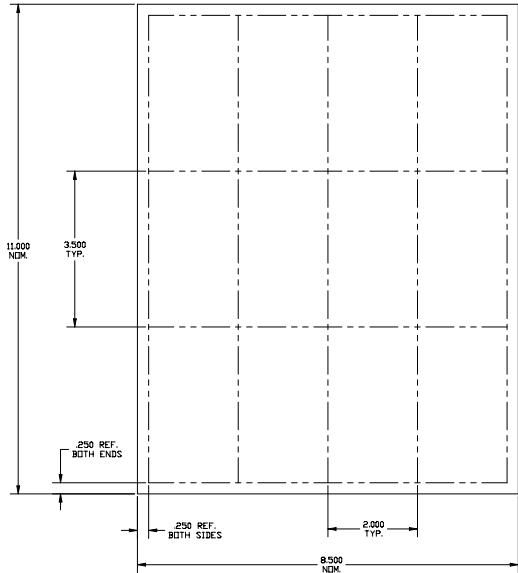

251 Wedcor Avenue • Wabash, Indiana 46992

Phone (260) 563-0641 • Fax (260) 563-4575

Email: info@martinyale.com • Website: www.martinyale.com