

MBM 1500S Tabletop Automatic Air Suction Paper Folding Machine

Instruction Manual



Provided by

MyBinding.com

When Image Matters.

Call Us at 1-800-944-4573

OPERATION MANUAL

MBM Air Suction Folder

Model 1500S

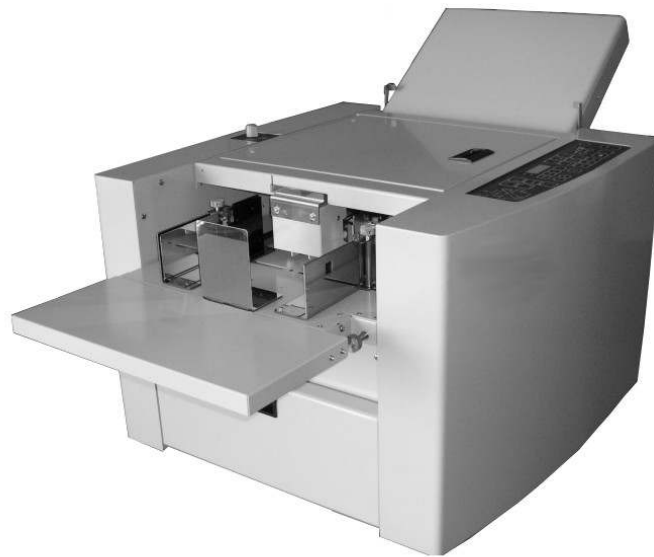

MBM Corporation

Version: 100611E(MBM)

Introduction

Thank you for purchasing UCHIDA Model “AeroFold” Air Suction Paper Folder. You should receive many years of reliable service from this machine. Compact and easy to use, “AeroFold” is sure to streamline your paper folding tasks, saving you valuable time. Please read the Operation Manual thoroughly before using this machine.

Contents

Safety Instructions	4
(1) Specifications	7
(2) Accessories	8
(3) Part Names.....	10
(4) Designation and Functions of Operations Panel.....	11
(5) Setup	12
(A) Setting of the Paper Ejection Table	12
(B) Setting of Table 1	13
(C) Setting of Table 2.....	14
(D) Setting of the Auxiliary Paper Feed Table.....	16
(E) Connecting Power Cabler	17
(6)Preparation of Paper	18
(7) Directions for use.....	19
(A) Standard folding of standard-size paper	19
(B) Standard Folding of Non-standard-size Paper.....	26
(C) How to Use the Interval Function	27
(8) Adjustment.....	29
(A) Fine Adjustment	29
(D) Paper Height Adjustment	38
(E) Standard of Suction Air and Paper Feed Table Height	39
(F) Separator Height Adjustment.....	40
G) Changing Location of Paper Ejection Roller.....	40
(9) Memory	40

(A) Fold Position Memory of Non-standard Papers.....	40
(B) Fold Position Memory of Standard Papers.....	41
(C) Clearing Memory.....	42
(D) Clearing all the memorized patterns.....	42
(10) Check Lamps, Error Codes and Troubles.....	43
(11) Troubleshooting and Cleaning.....	46
(A) Troubleshooting of Paper jam.....	46
(B) Cleaning of Sensors.....	47
(C) Cleaning of Fold Roller and Paper Feed Belt.....	48

Safety Instructions

Definition of Symbols and Notes

The following names and signs stand for possible dangers.



Danger

This symbol stands for immediate danger. Disregarding these instructions may cause severe injury.



Caution

This symbol stands for a potentially dangerous situation. Disregarding these instructions may lead to injuries or damage to property.

Danger	
	Make sure that the machine is electrically grounded to prevent electrical shock.
	Operate the machinery within reasonable voltage range. There is a risk of electrical shock or fire if a higher or lower voltage is used, or if an electric current is utilized with a frequency not within the range stated above.
	Do not place any object on top of this machine. There is a risk of electrical shock or fire if water or any foreign object enters the machine.
	Handle the power cord with care. There is a risk of electrical shock or fire if the cord is damaged, broken, or placed under a heavy object.
	Do not insert or remove the power plug when water is present.
	Do not remove the cover of this machine. There is a risk of an electrical shock.
	Do not reconfigure the electronics of this machine. There is a risk of an electrical shock or fire.
	Do not operate the machine if it is emitting smoke or a strange odor. Turn off the machine, unplug it from the outlet and contact your dealer.
	Do not operate the machine if the power cord is generating heat or emits a strange smell. Turn off the machine, unplug it from the outlet and contact your dealer.
	If a foreign object enters into the machine, turn off the power switch and unplug the power plug, then consult your dealer.
In the event of a thunderstorm, unplug the machine.	

Caution	
	Keep hair, clothing, and jewelry away from the machine while operating. Serious injury may result.
	Do not put the machine on an unstable or slanted surface. Doing so may cause the machine to drop or fall over, causing damage and possible injury.
	Store and operate the machine in a clean, dust-free environment with low humidity. Avoid areas with high moisture, extreme temperatures and excessive dust, as these conditions may cause machine failure or electrical shock. Operate the machine at the temperature of 5 degrees to 35 degrees C.
	Be sure to grasp the power cord by the plug when unplugging it from the electrical outlet. Not doing so may cause damage to the cord and possible electrical shock or fire.
	Be sure to pull the power plug out of the electric outlet before moving the machine. Not doing so may cause damage to the cord and possible electrical shock or fire.
	Unplug the power plug from the electrical outlet when this machine is not in use.
	The socket-outlet shall be installed near the equipment and shall be easily accessible.

WARNING_1

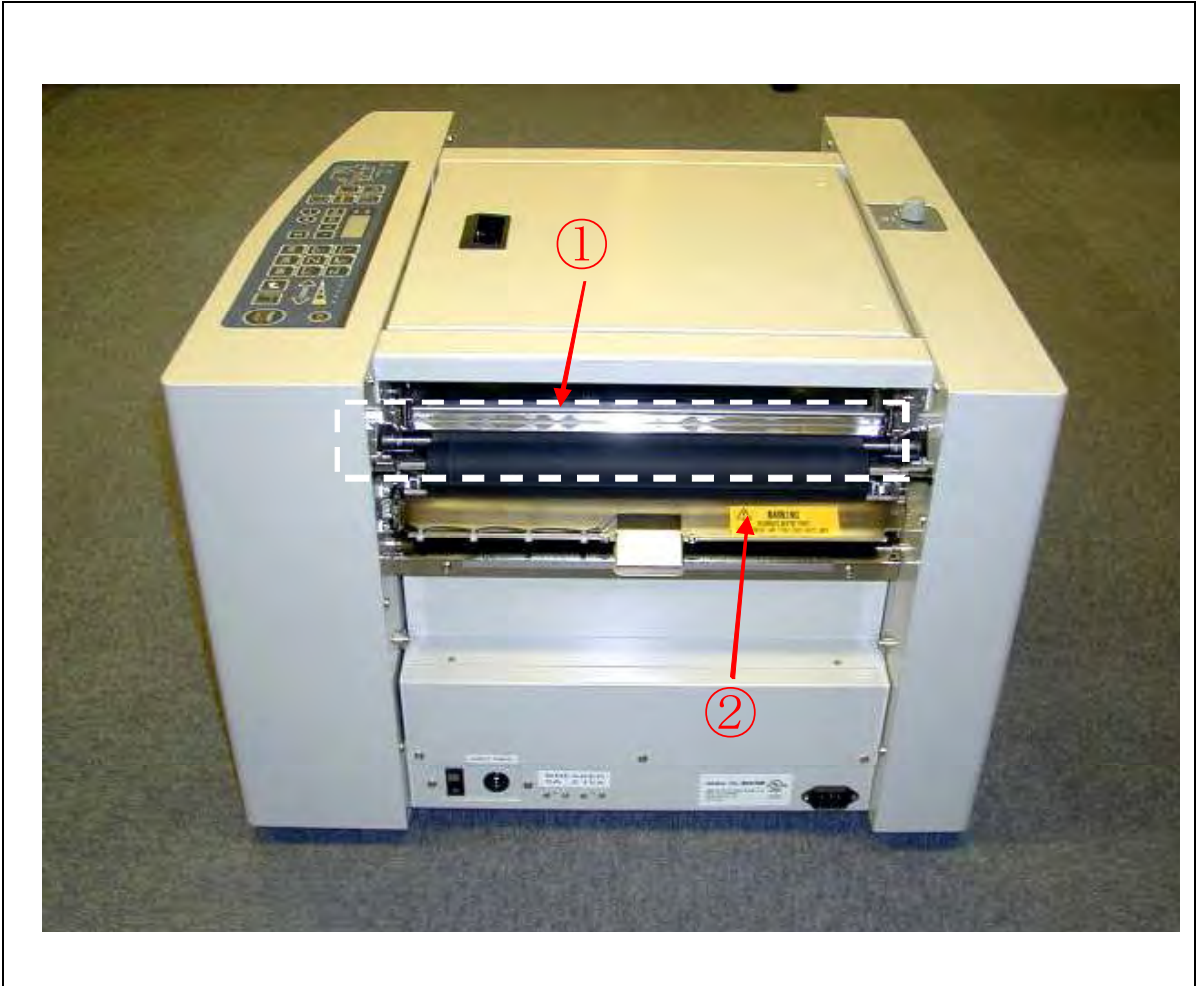

- ① : Moving Parts
- ② : Warning Label

WARNING
HAZARDOUS MOVING PARTS
KEEP FINGERS AND OTHER BODY PARTS AWAY.

WARNING_2

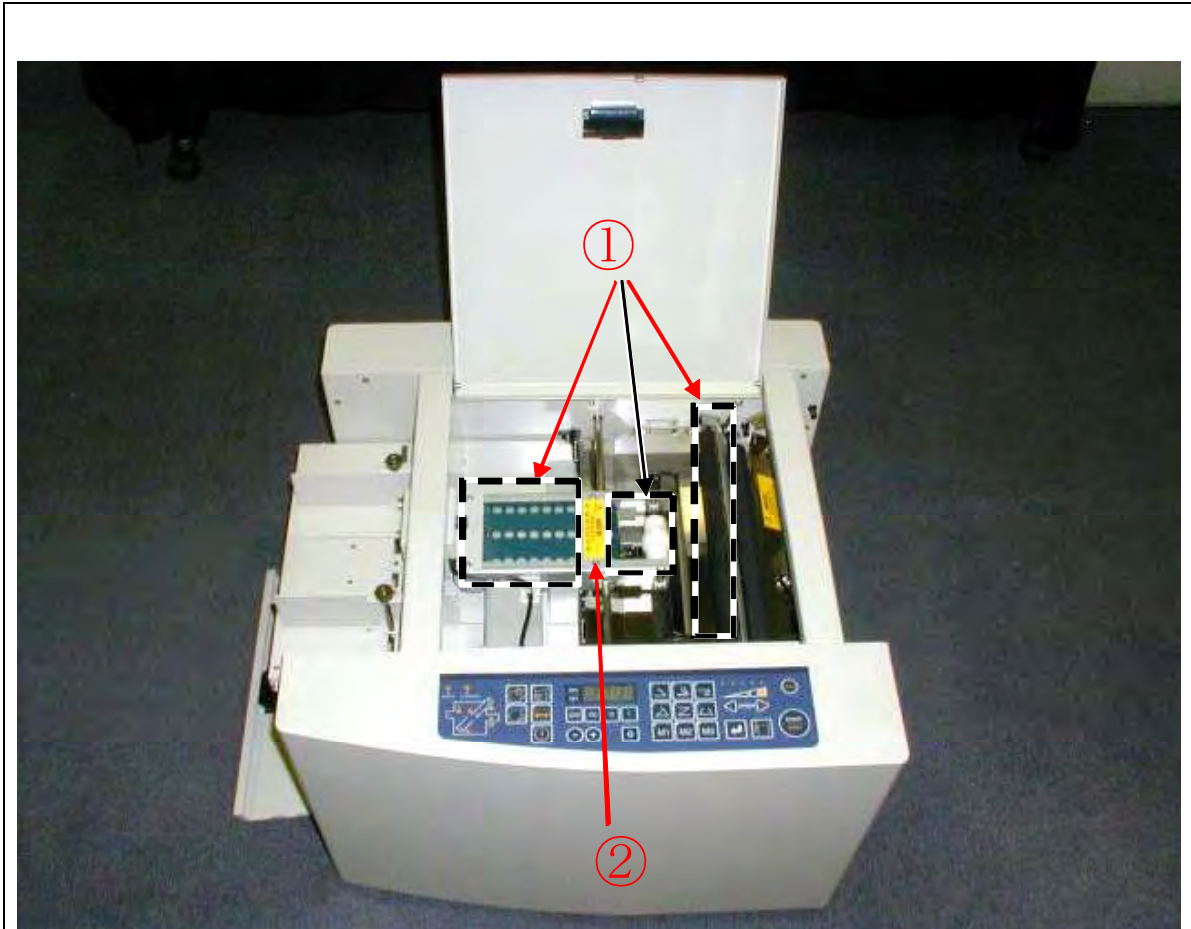

- ① : Moving Parts
- ② : Warning Label



WARNING
HAZARDOUS MOVING PARTS
KEEP FINGERS AND OTHER BODY PARTS AWAY.

(1) Specifications

Model:	MBM 1500S Air Suction Folder
Paper sizes:	4.72 x 8.27 – 13.00 x 19.21 inch
Paper weight:	Bond 13.9 to 42.5 lbs (Bond 42.5 – 61.1 lbs for single fold with limited paper)
Paper quality:	Offset paper, Coated Paper
Folding patterns:	Single, Letter, Zigzag, Double Parallel, Fold-out and Gate* (*Gate is limited to certain papers)
Folding dimensions:	Maximum folding dimensions Table 1: 14.4 inch Table 2: 9.6 inch
	Minimum folding dimensions Table 1: 2.1 inch Table 2: 2.1 inch Smallest adjustment increment: 0.004 inch
Paper feed system:	Belt Suction Feed system
Maximum capacity:	500 sheets, 20 lbs Bond
Folding speed:	2,500 to 15,000 sheets per hour (single fold using Letter size paper) Speed adjustable in 5 steps.
Control system:	Automatic setting by built-in microcomputer
Other functions:	Automatic paper size detector (Ledger, Legal and Letter) Four-digit counter with addition/subtraction modes Paper Jam detector/indicator Skew correction 18 memories for standard paper size (fine adjusted) 3 special memories for out of standard paper size
Noise	86dB, 20 lbs Bond, double parallel at the highest speed level 5
Power source:	100 thru 120 VAC, 2.6A/240W, 50/60Hz
Dimensions:	51.2 (W) × 23.6 (D) × 23.2 (H) inch (in use) 46.1 (W) × 27.6 (D) × 25.6 (H) inch (in storage)
Weight:	Net: 154.3 lbs Shipping (Approx.): 198.4 lbs
Options:	Perforation unit Scoring unit

(2) Accessories

After un-boxing, make sure that the following accessories are present. Please contact your local dealer immediately if anything is missing.

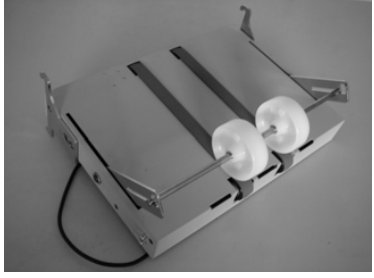
Accessories	Number	
Table 1	1	
Table 2	1	
Auxiliary paper feed table	1	
Paper ejection table	1	

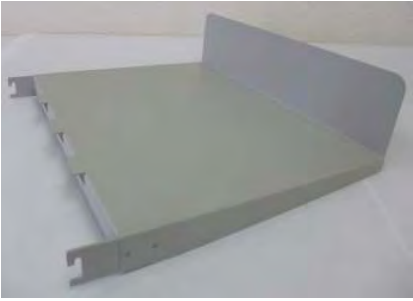
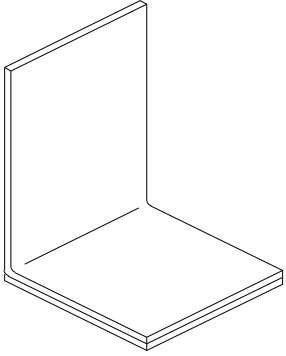
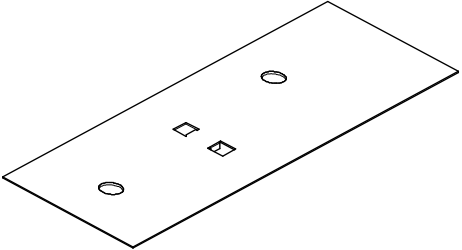
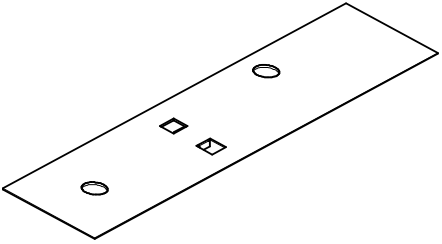
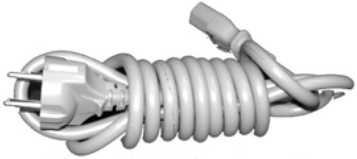
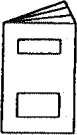
Auxiliary paper ejection table	1	
L Stopper Guide	1	
Paper Spacer for Ledger and larger	1	
Paper Spacer for Letter and smaller	1	
Power cable	1	
Operation Manual	1	

(3) Part Names

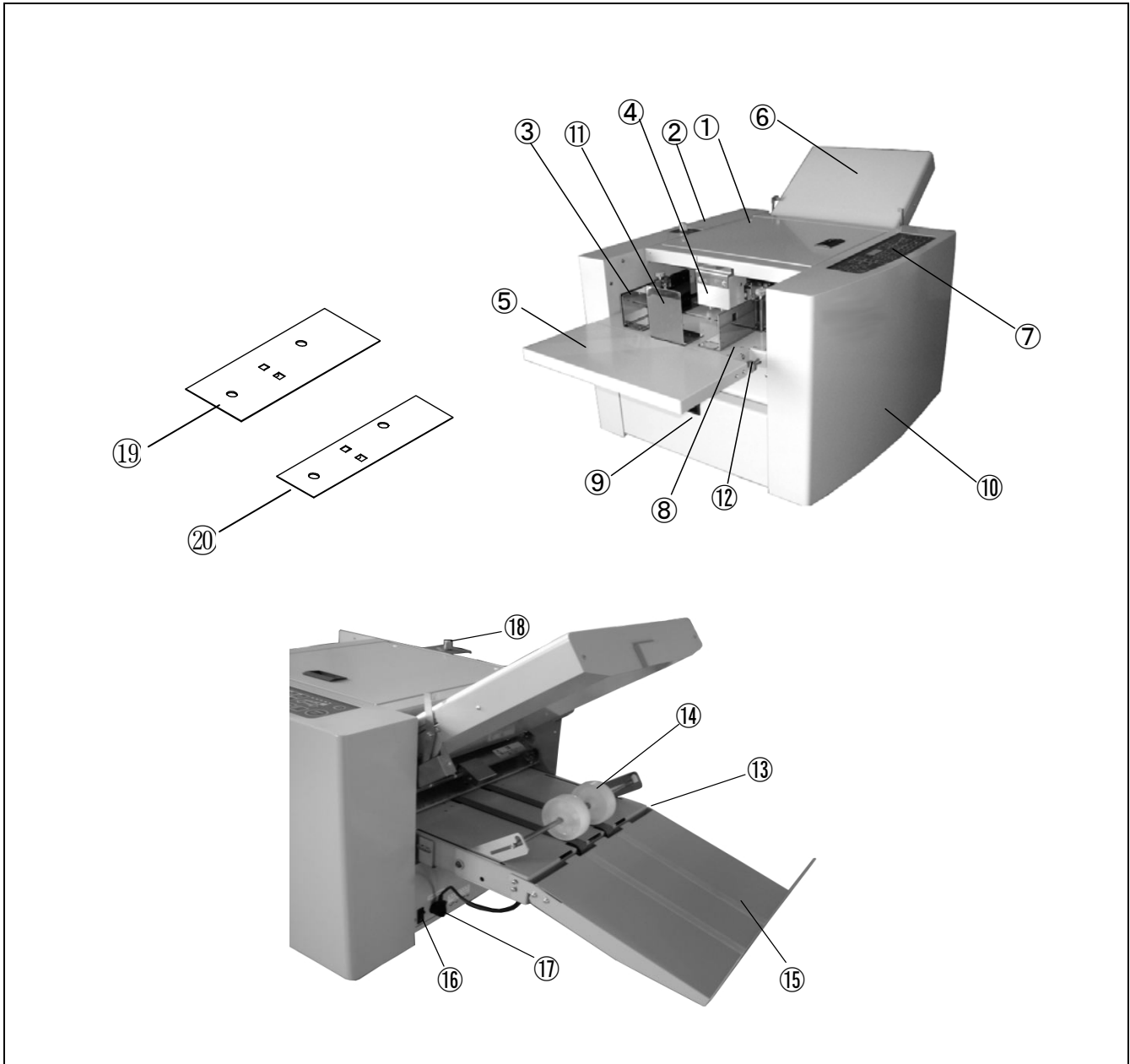

	Name	Number	Name
①	Top cover	⑫	Skew adjustment knob
②	Left side cover	⑬	Paper ejection table
③	Paper guide(L w/spring loaded & R)	⑭	Paper ejection roller
④	Paper height detection sensor	⑮	Auxiliary paper ejection table
⑤	Auxiliary feed table	⑯	Power switch
⑥	Table 1	⑰	Paper ejection table socket
⑦	Control panel	⑱	Air adjustment knob
⑧	Paper feed table	⑲	Paper Spacer for Ledger and larger
⑨	Door for the table 2	⑳	Paper Spacer for Letter and smaller
⑩	Right side cover	*	Table 2
⑪	L Stopper guide		

* Table 2 is set under the paper feed table in the machine, which you find when opening the door for the table 2, ⑨.

By placing ⑱ or ⑳ Paper Spacer on the paper feed table, make the paper stack flat.

(4) Designation and Functions of Operations Panel

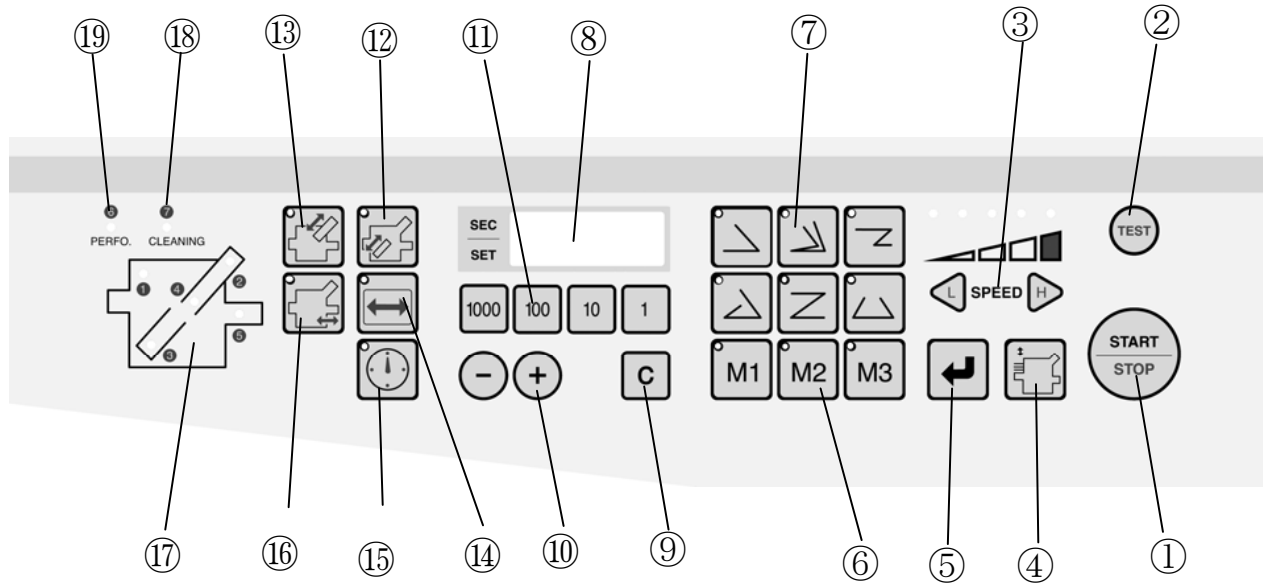

No.	Designation/Indication	Function
①	START/STOP key	Starts and stops machine.
②	TEST key	1) <u>Test folds</u> two sheets without counting. 2) Also <u>test blow</u> without folding, when pressed more than 2 seconds.
③	Speed adjustment key	Adjusts speed.
④	Paper feed table up/down key	Moves up and down the paper feed shelf.
⑤	Store key	Fold position after adjustment is stored.
⑥	Memory 1/2/3 key	Three special fold types are stored.
⑦	Fold type key	Six fold types can be input and stored.
⑧	Counter	Shows the number of sheets, the position of the stopper pin of Table 1 and 2, and paper size.
⑨	Clear/Reset key	Clears the counter / resets after an error.
⑩	+/- key	Used for adjusting the position of the stopper of Table 1 and 2, the position of paper ejection roller, and paper length
⑪	Numerical key	Used for inputting the number of sheets to be folded and the length of non-standard size paper
⑫	Table 2 stopper move mode key	Indicates when the position of stopper of Table 2 is adjusted.
⑬	Table 1 stopper move mode key	Indicates when the position of stopper of Table 1 is adjusted.
⑭	Paper length input mode key	Indicates when paper length is input
⑮	Interval key	Sets a certain time of interval to stop paper feed.
⑯	Paper ejection roller move key	Indicates when the position of the paper ejection roller is adjusted.
⑰	Check lamp	Indicates when paper stock runs short, or the location of paper feed trouble.
⑱	Cleaning lamp	Indicates when cleaning of the FEED section (belt, roller) is necessary. It lights every after 10,000 peaces of paper are fed. For reset, turn on the machine holding down – key. You can disable this function when you turn up the machine keep pushing [single (Fold type)] key. You can activate this function again when you turn up the machine with [gate(Fold type)] key pushed.
⑲	Perforation mode lamp	Indicates when the optional perforating unit is installed.

(5) Setup

(A) Setting of the Paper Ejection Table

Install the paper ejection table to the main machine body.

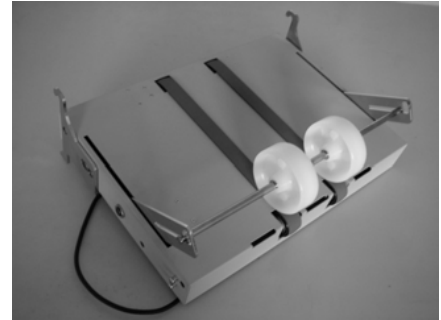

Install the table by putting its hook on the guide pins at two sides.

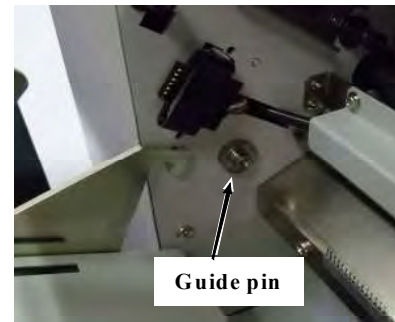

Make sure that the hooks are securely put on the guide pins.

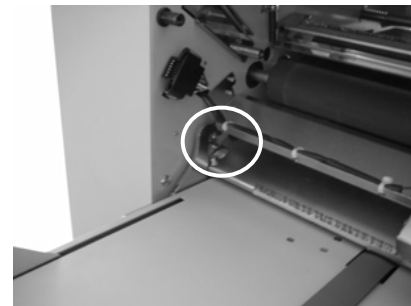

Install the auxiliary paper ejection table to the paper ejection table.

Auxiliary paper ejection table

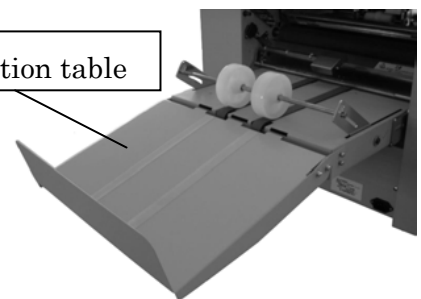

Join the connector of the paper ejection table to the machine.



(B) Setting of Table 1

Slide Table 1 bracket (RH&LH) slowly to diagonal direction along the guide of the main machine body.

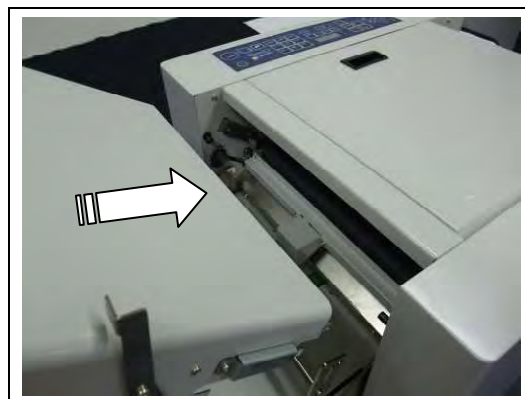

Table 1 guide on the operator side

The Table 1 connector is set on the operator's side. Give caution not to damage the connector when installing the Table 1.

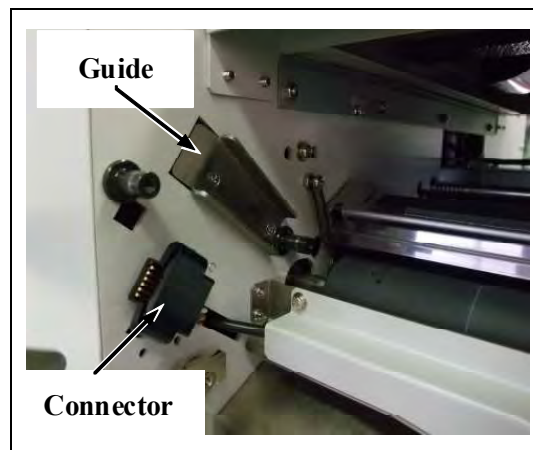
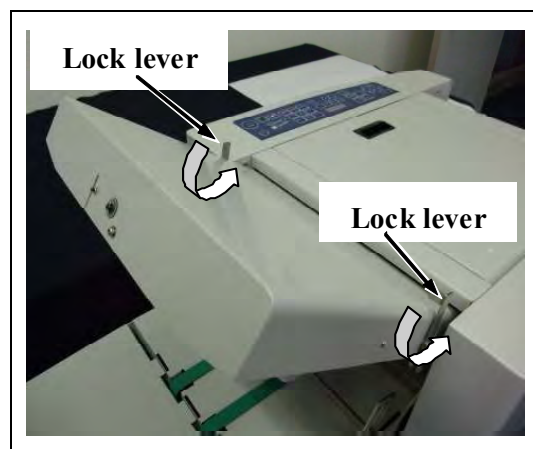

Table 1 guide on the opposite side of the operator.



Install Table 1 to the main machine body securely and fix it using the lock levers located on both sides. (Move top of the lock lever to the arrow direction as shown in the right figure.)



(C) Setting of Table 2

Make sure that no paper is loaded on the paper feed table, and press the paper feed table Up and Down Key so as to raise the table until it stops at the uppermost point.

For installing or removing table 2, do it after raising the paper feed table up to the highest point using the paper feed table Up and Down Key.

In case the paper feed table is located at any place other than the lowermost point, if the paper feed table Up and Down Key is pressed, it moves down to the lowermost point. Therefore, press the paper feed table Up and Down Key again to raise it to the uppermost point.

In case the paper feed table is located at the lowest point, if the paper feed table Up and Down Key is pressed, the table moves up.

If the paper feed table Up and Down Key is pressed while the paper feed table is in operation, the paper feed table stops motion.

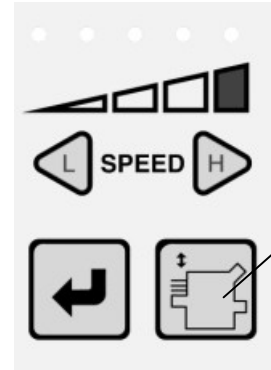

Open the door for the table 2.



Place the Guide Bracket of Table 2 on the Table Guide 2 on both sides.

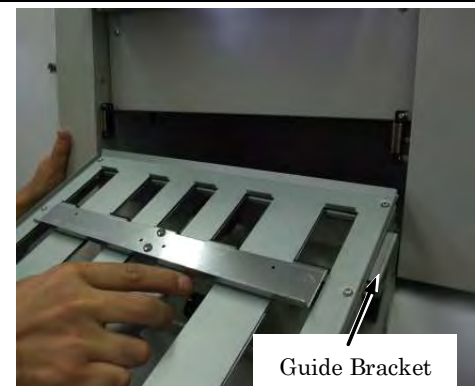
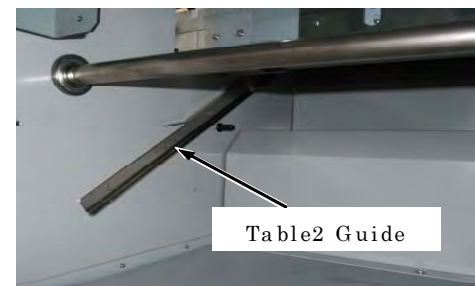

Push Table 2 in the direction of arrow and along Table Guide 2.
Push Table 2 until it is securely locked.

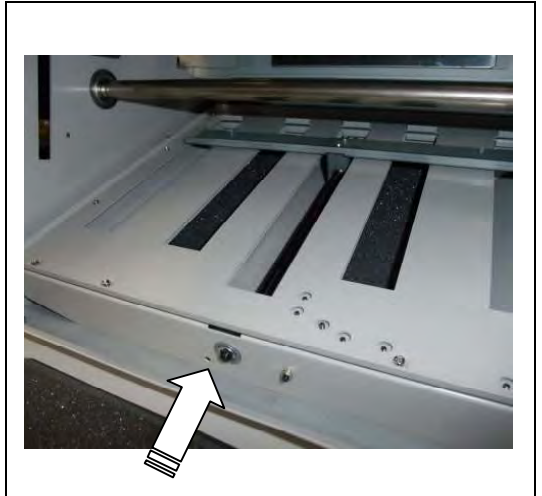

Make sure that Table 2 is securely locked.

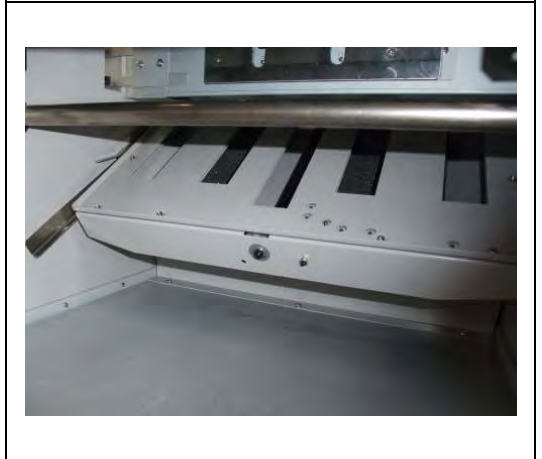

Insert the connector of Table 2.



Close the door for the table 2.



(D) Setting of the Auxiliary Paper Feed Table

Have the Paper feed side table parallel and set the tip of metal fitting of that between fixed pin No.1 and No.2

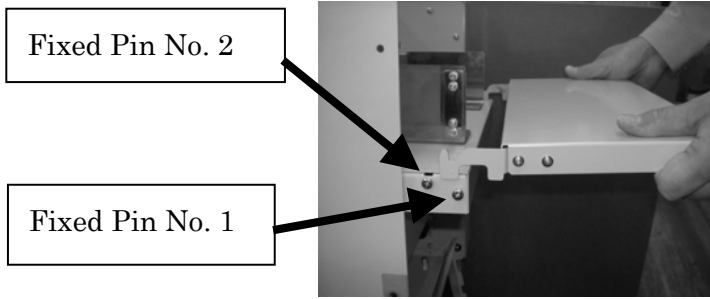

Put the Paper feed side table down as it is and catch the fixed pin No.1



Put the Paper feed side table up diagonally, the tip of them should be below fixed pin No.2 and pull down the paper feed side table.



Please check the tip of the paper feed side table catch the fixed pin No.1 and No.2.

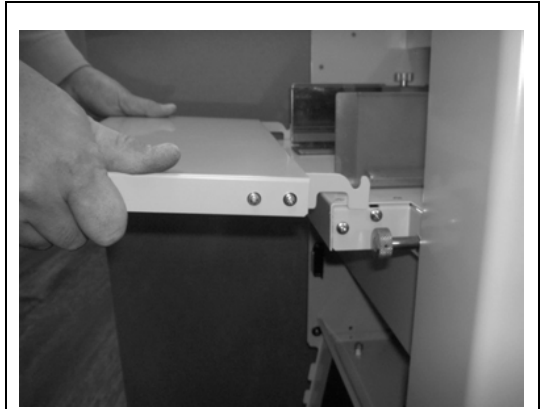

(E) Connecting Power Cabler

Insert the power cable into inlet for machine and the other end to power outlet.

Caution:

Do not use a power cable other than the one provided.

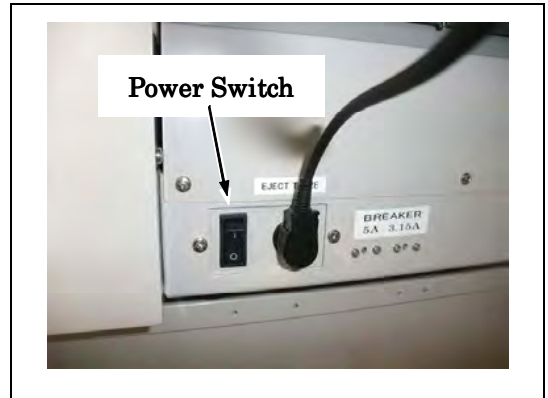
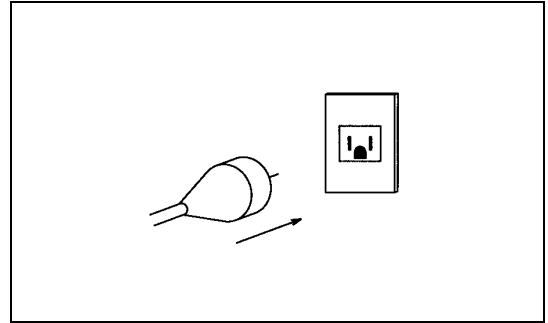

(6)Preparation of Paper

Fan out the paper sufficiently.

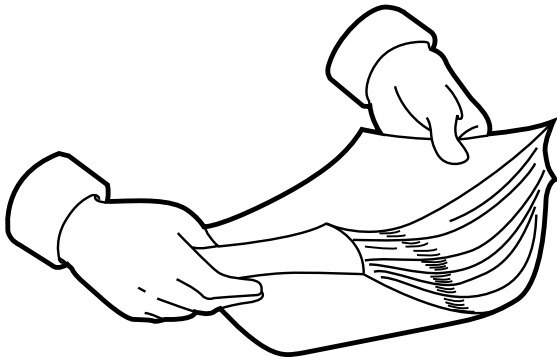

Jog the paper. If there is a sheet of paper whose edge is bent or warped, it must be straightened.

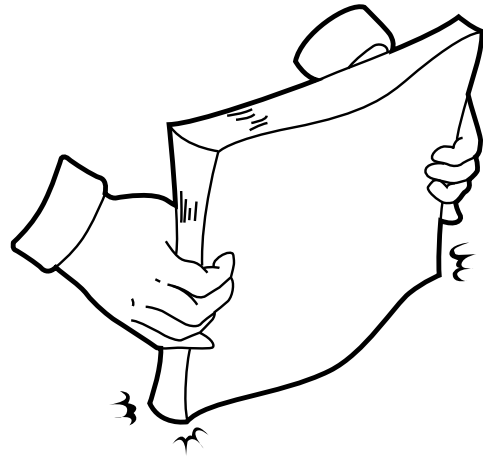

Use dry paper.

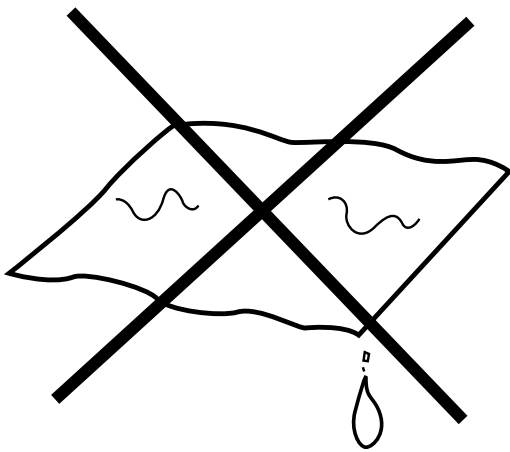

Keep the stacking capacity.

Max. 500 sheets (20 lbs Bond)

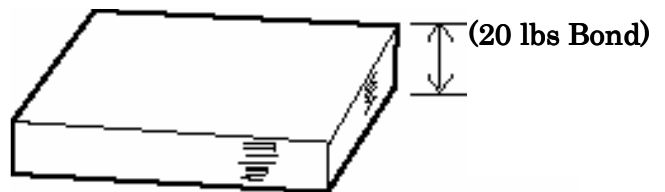

It should be noted that when paper as thick as 1.97 inch or more is stacked on the station, smooth collation will not be done. Also it may cause damages to the machine.

(7) Directions for use

To start using this machine, following is described for paper size A3 and 80g/m2 offset paper with Single Fold at medium speed 3. This introductory operation makes the user to operate the machine easier for applied applications.

As the user becomes familiar with the machine, it is recommended to use other paper sizes, paper weights, folding patterns and different speeds.

(A) Standard folding of standard-size paper

Prepare approximately 200 sheets of Ledger, 11 x 17 inch, 20 lbs Bond. Paper corners must be exactly 90 degree angles.

1. Turn power switch on.

2. Skew Adjustment Knob for Feed Table

Make Paper Feed Table square to machine Front Wall by rotating Skew Adjustment Knob.

Center the scale indicator.

NOTE: Skew Adjustment Knob is used for the paper which weighs more than 34.3 lbs Bond unless otherwise needed.

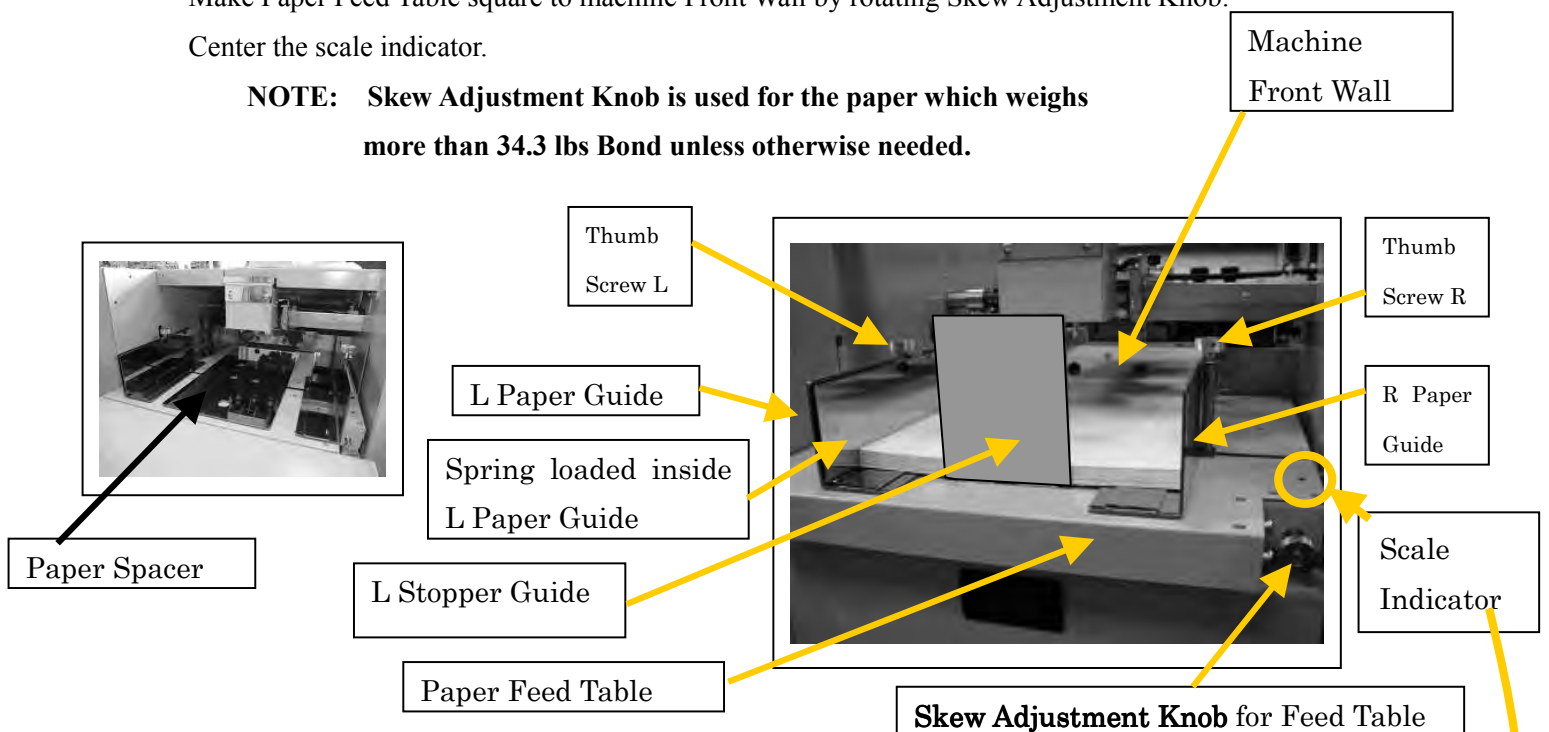

3. Feed Roller Direction Adjustment Dial

Loosen Thumb Screw. Rotate Feed Roller Direction Adjustment Dial and let Pin centered to the Scale.

Tighten Thumb Screw.

NOTE: Feed Roller Direction Adjustment Dial is used for the paper which weighs less than 34.3 lbs Bond unless otherwise needed. Use Skew Adj. Knob when Feed Roller Direction Adj. Dial is not effective.

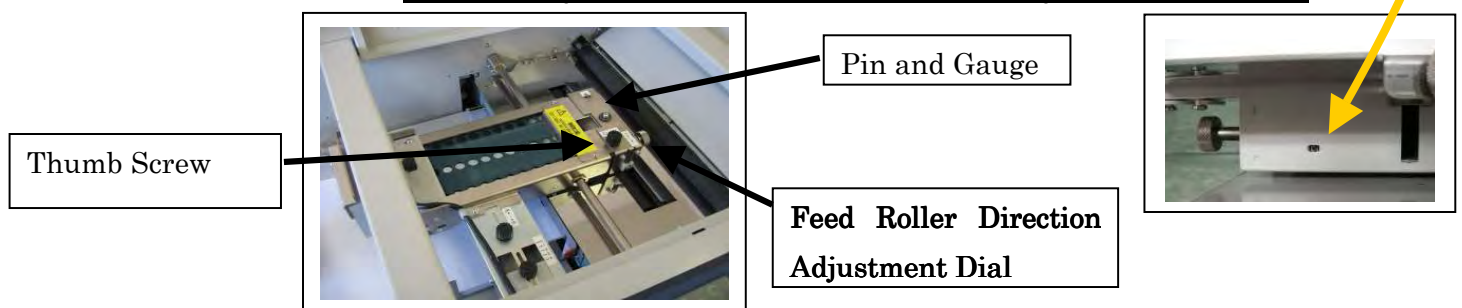

- Set sheets of paper on the paper Feed Table. By pressing Up and Down Key, lower the Feed Table before placing paper stack.

When setting sheets of paper on the paper feed table, press the paper feed table Up and Down Key. In case the paper feed table is located at any place other than the lowest point, it moves down to the lowest point.

Also, in case the paper feed table is located at the lowest point, if the paper feed table Up and Down Key is pressed, the table moves up.

If the paper feed table Up and Down Key is pressed while the paper feed table is operating, the table stops.

Note: In case of installing or removing table 2, do it after raising the paper feed table up to the highest point using the paper feed table Up and Down Key.

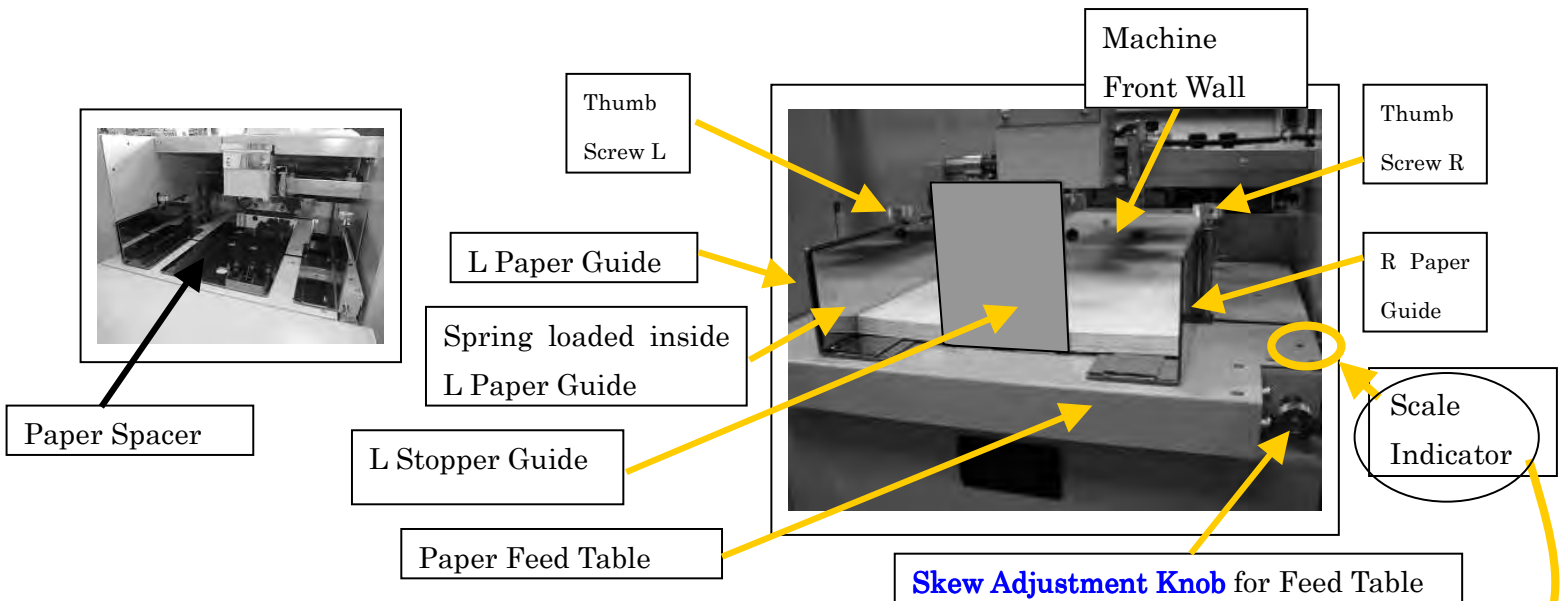
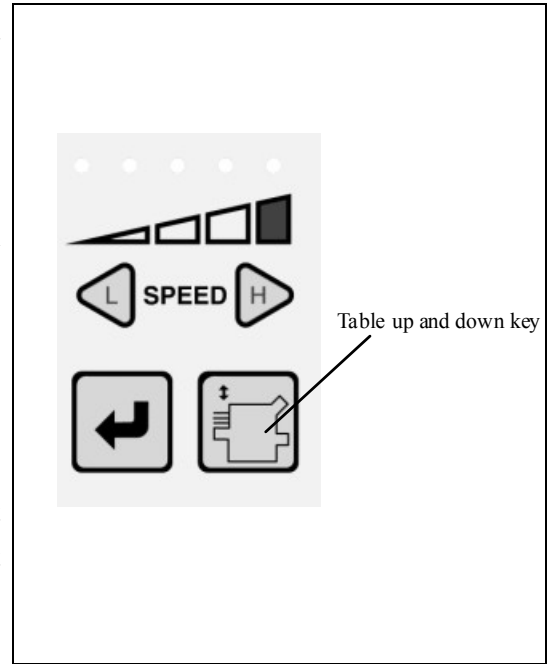

- Loosen the paper guide set screws and adjust the L and R paper guide to fit the width of the paper.

- Set the paper spacer matching to the size of paper on the paper feed table. (In this case Ledger Size)

- Neatly arrange paper and place it on the feed table.

- Adjust Paper Side Guides fit to the paper and tighten the Set Thumb Screw. Make sure that the Spring loaded Paper Guide which is installed inner of the L Paper Guide (opposite side from control panel) slightly push paper edge with its spring. Push paper stack against machine Front Wall to leave no gap.

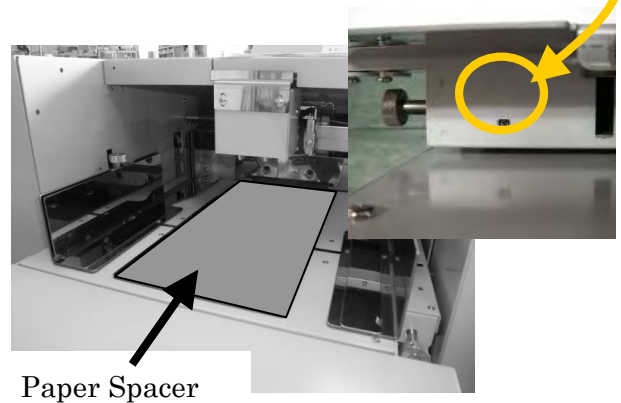

9. Place L Stopper Guide at the back end of the paper stack.

Note :

Make sure that there is no space among the paper, Machine Front Wall and the paper guides.

Otherwise it may originate paper skew. If gap is observed due to incorrect cutting of paper etc., adjust it by the Skew Feed Table Adjustment Knob.

10. Press Single Fold Key and the Key lights.

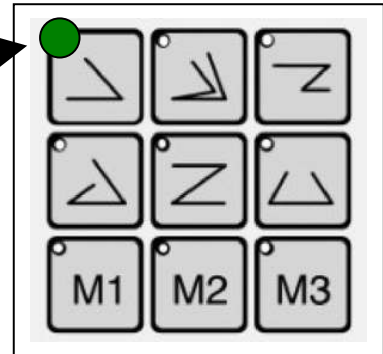

11. Select Speed at Medium (3).

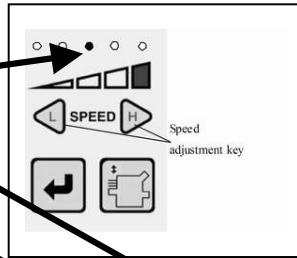

12. Select 3 rows for Suction Belt.

13. Set Suction Strength Window at 4.

14. Set Paper Feed Table Height Adjustment Knob at M position.

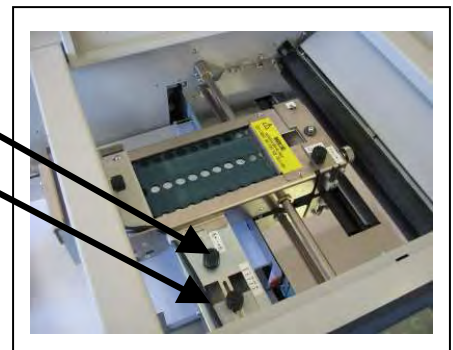

15. Press Test Mode Key for more than 2 seconds until buzzer sounds.

Then air starts to blow without feeding paper and Paper Feed Table rises.

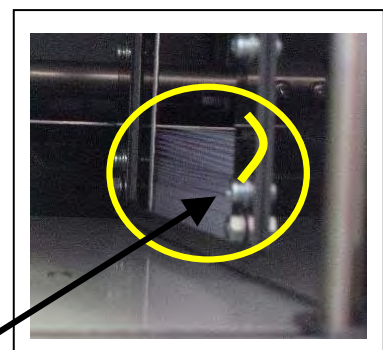
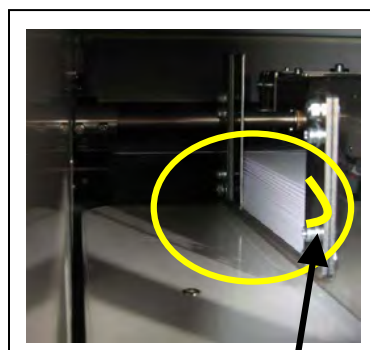
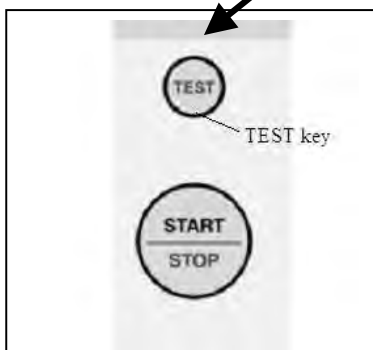

15. Adjust Air Blow Control Knob so as that the top 7 to 10 sheets flies in the air with stability/steadily and without sticking two sheet together. Dial is set more or less at fine line (week blow) as right picture for 20 lbs Bond paper.

Air Blow Control Knob



16. Press Test Key again and two sheets come out with single fold.

NOTE: (1) By pressing Test Key during blow test mode, machine test folds and automatically goes out of blow test mode.

(2) Or, by pressing START/STOP Key, blow test mode ends.

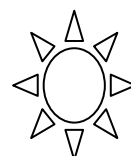

17. Check 2nd sheet to see if there is any skew.

Leading Feed Edge

(1) Skewed to the right.

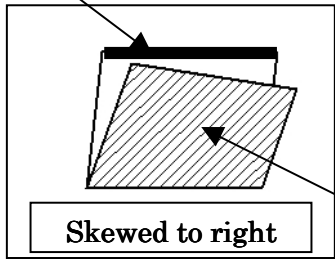

- (a) Loosen Thumb Screw and slightly turn Feed Roller Direction Adjustment Dial counter-clockwise. Tighten Thumb Screw again.
- (b) Press Test Key and check 2nd sheet if there is still any skew.
- (c) Repeat (a) and (b) above, and any skew should be corrected by Feed Roller Direction Adjustment Dial.

Upper side when paper was placed on Feed Table

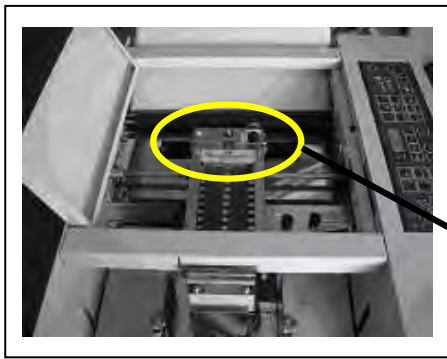

Feed Roller Direction Adjustment Dial

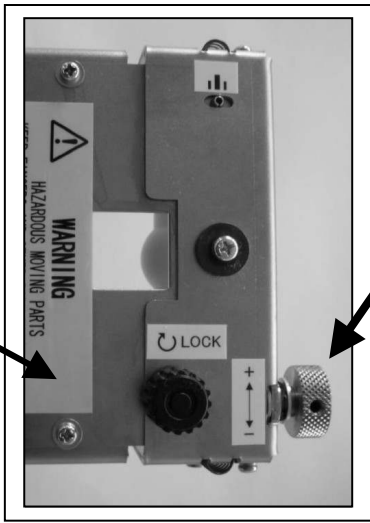

Leading Feed Edge

(2) Skewed to the left

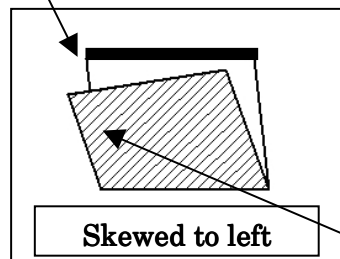

- (a) Loosen Thumb Screw and slightly turn Feed Roller Direction Adjustment Dial clockwise. Tighten Thumb Screw again.
- (b) Press Test Key and check 2nd sheet if there is still any skew.
- (c) Repeat (a) and (b) above and any skew should be corrected by Feed Roller Direction Adjustment Dial.

Upper side when paper was placed on Feed Table

17. After skew is corrected, make trial fold of 10 sheets and make sure that obviously apparent skew is not found for 2nd sheet till 10th sheet.

Note 1st sheet is not checked because it is folded before machine is in stabilized motion.

Through above procedures, basic operation of the machine has been learnt. Now, we try in applied applications.

8. Selection of fold type

One of the six folding types (Single, Double Parallel, Fold-out, Letter, Zigzag, and Gate) can be selected. Press the desired fold type key.

Example:

When selecting the Single folding type, the button illuminates as shown in the right figure.

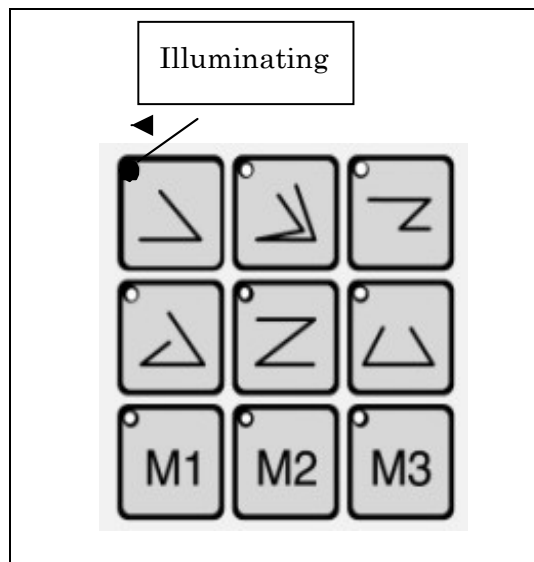

9. Setting of the number of sheets of paper to be folded

When inputting the number of sheets of paper (preset counter): Press the C Key to display “0” on the counter.

Input the value of necessary number using the numerical keys from “1” to “1000”.

Then, the machine operates until the input value becomes “0” (zero).

If the value displayed on the counter is “0”, the machine operates until there is no paper loaded on the paper feed shelf.

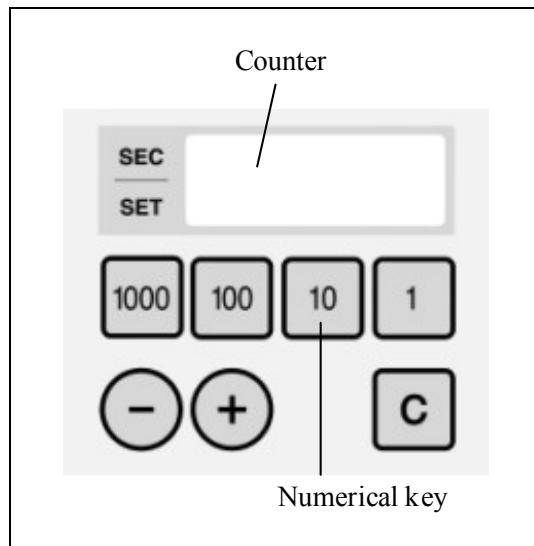

10. Setting of the speed

When setting the speed:

The speed can be changed by using “H” key or “L” key.

The third lamp from the left (lamp in the middle) shows the standard speed.

Note that the lamp further on the right side from the middle shows the higher speed is set while the lamp further on the left side shows the slower speed is set.

Set the speed according to the type of paper or fold.

Note: When folding thicker paper, machine may not fold at lower speed. In this case, increase folding speed.

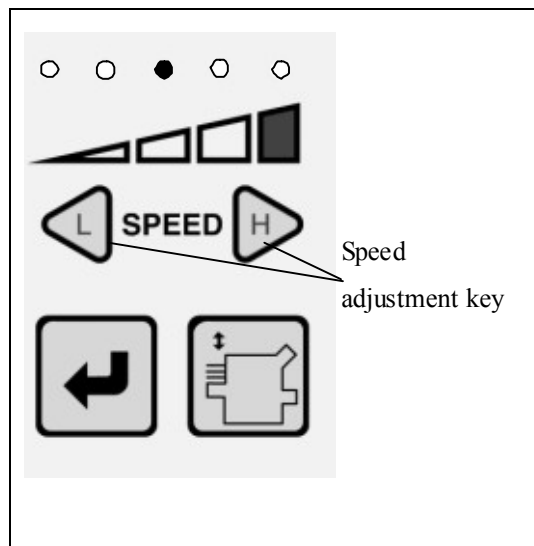

13. Press Test Mode Key for more than 2 seconds until buzzer sounds.
Then air starts to blow without feeding paper and Paper Feed Table rises.

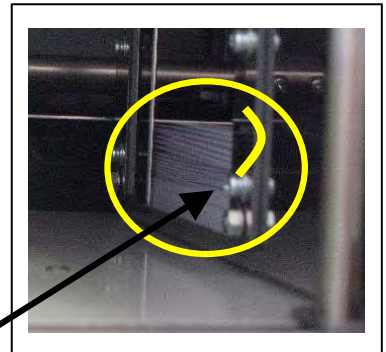
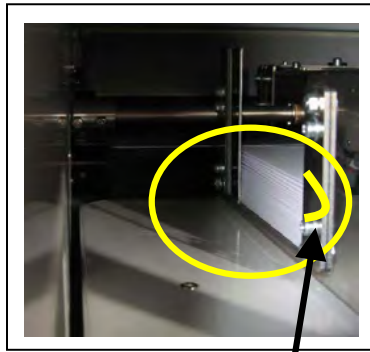
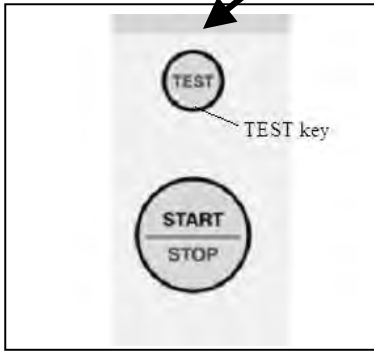

14. Adjust Air Blow Control Knob so as that the top 7 to 10 sheets flies in the air with stability/steadily and without sticking two sheet together. Dial is set more or less at fine line (week blow) as right picture for 20 lbs Bond paper. Heavier the paper is the more air blow is needed.

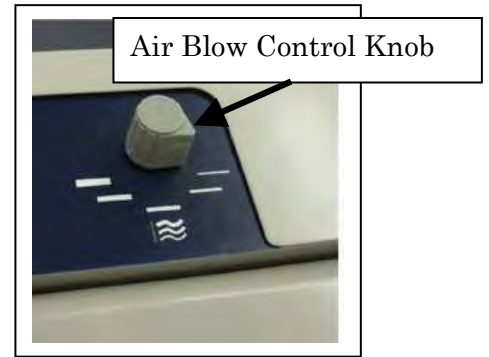

15. Press Test Key again and two sheets come out with single fold.

NOTE: (1) By pressing Test Key during blow test mode, machine test folds and automatically goes out of blow test mode.

(2) Or, by pressing START/STOP Key, blow test mode ends.

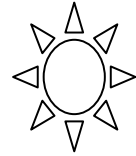

16. Check 2nd sheet to see if there is any skew.

Leading Feed Edge

(1) Skewed to the right.

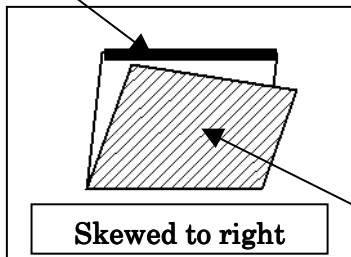

- (a) Loosen Thumb Screw and slightly turn Feed Roller Direction Adjustment Dial counter-clockwise. Tighten Thumb Screw again.
- (b) Press Test Key and check 2nd sheet if there is still any skew.
- (c) Repeat (a) and (b) above, and any skew should be corrected by Feed Roller Direction Adjustment Dial.



Feed Roller Direction Adjustment Dial

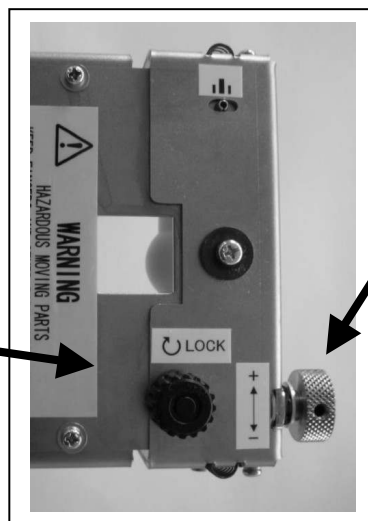
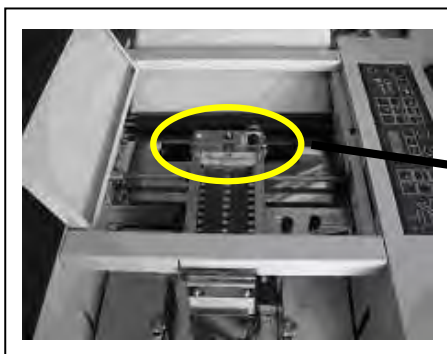

Leading Feed Edge

(2) Skewed to the left

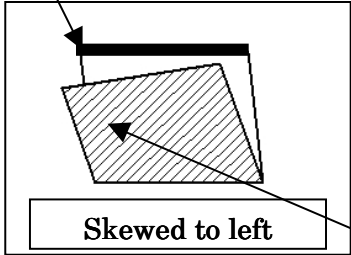

- (a) Loosen Thumb Screw and slightly turn Feed Roller Direction Adjustment Dial clockwise. Tighten Thumb Screw again.
- (b) Press Test Key and check 2nd sheet if there is still any skew.
- (c) Repeat (a) and (b) above and any skew should be corrected by Feed Roller Direction Adjustment Dial.

Upper side when paper was placed on Feed Table

17. After skew is corrected, make trial fold of 10 sheets and make sure that obviously apparent skew is not found for 2nd sheet till 10th sheet. Note 1st sheet is not checked because it is folded before machine is in stabilized motion.

Note:

When folding line does not match as desired, it is required to adjust the stopper position of Table 1 or Table 2. (Refer (A) Fine Adjustment page 28.)

When double feed occurs or paper is not fed, it is required to adjust air blow strength and paper height. (Refer to (C) Air adjustment of page 37 or (D) Paper height adjustment of page 38)

9. Start folding

Continuous folding:

When the START / STOP key is pressed, the machine will continuously fold.

When the START / STOP key is pressed while the machine is in operation, the machine will stop, but addition on the counter will continuous.

If you wish to fold only the number of sheets desired, use the subtraction counter function.

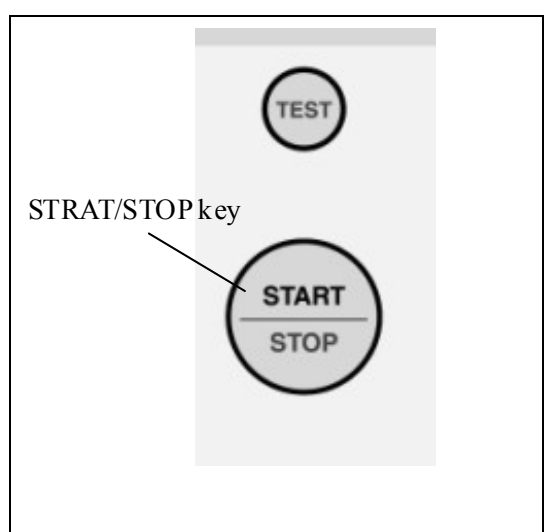

(B) Standard Folding of Non-standard-size Paper

1. Selecting a fold type.
2. Input of the total paper length

Measure the paper length.

The arrow indicates the direction of paper feed.

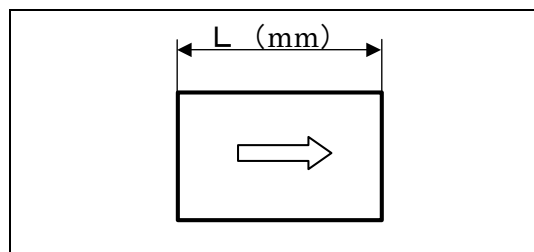

Press Paper Length Input Mode Key.

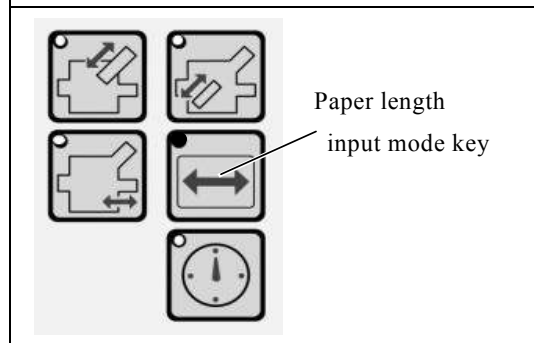

Input the paper length using the numerical keys.

The unit for input is mm.

For example: Input paper length of 11.42 inch

Press [1000] key 1 time. (Input unit of 10 inch)

Press [100] key 1 time. (Input unit of 1 inch)

Press [10] key 4 times. (Input unit of 0.1 inch)

Press [1] key 2 times. (Input unit of 0.01 inch)

Note: Units of numerical keys are one unit higher than the unit of length

The available input range is 13.0 to 19.25 inch.

After the length is set, press the Paper Length Input Mode Key again to fix it. When any value other than standard ones is input, the lamp flashes. To clear the input value, press the Length Input Mode key and press the “C” key.

Max input for Table 1 is 366mm and Table 2 is 245mm.

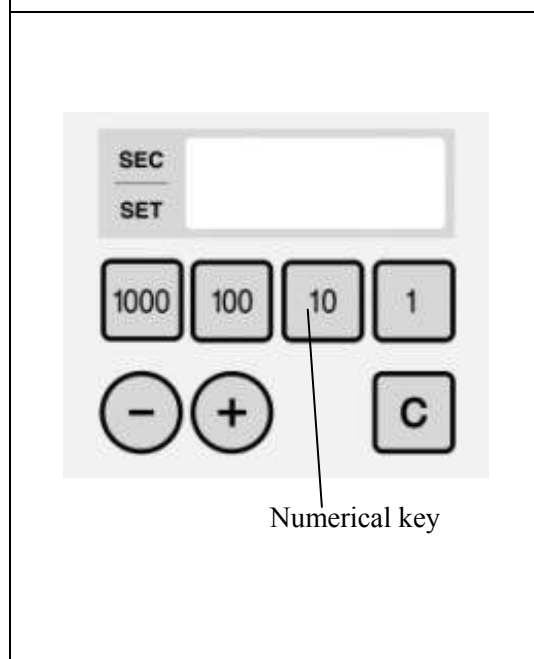

Note:

Stopper position of Table1 and Tables2. Also refer page 31.

Example)

Table1 $11.0 \text{ inch} \times 2/3 = 7.33 \text{ inch}$

Table2 $11.0 \text{ mm} \times 1/3 = 3.67 \text{ inch}$

	Table 1	Table 2
SINGLE	—	1/2
DOUBLE PARA LLEL	1/2.	1/4
FOLD-OUT	1/4	1/4
LETTER	2/3	1/3
ZIGZAG	1/3	1/3
GATE	3/4	1/2

(C) How to Use the Interval Function

After selecting a fold type,
Press the Interval key.
The lamp on the Interval Key illuminates.

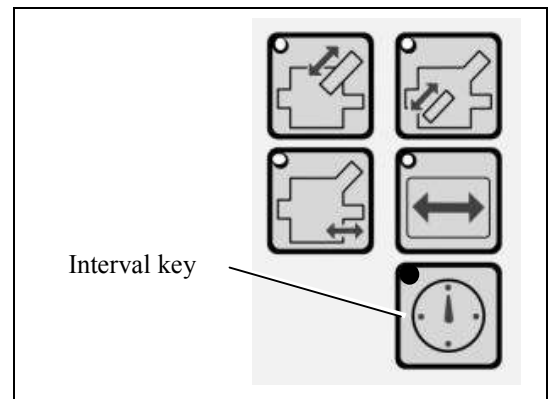

The bar on the display right beside "SEC" flashes.
Using the numerical keys "1" or "10", input a desired interval time for intermittent operation.
* 1 to 99 seconds can be set as the interval time.

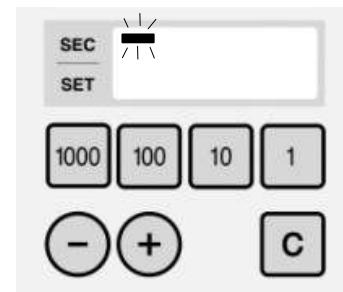

Press the Interval key again.
The bar on the display right beside "SET" flashes.
Using the numerical keys "1", "10" or "100", input a desired number of sheets of paper to be folded for each interval.
* 1 to 999 sheets can be set for interval operation.

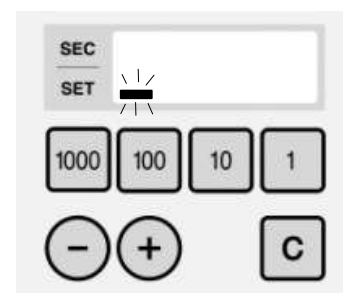

Press the Interval key again.
Then, the lamp on the Interval key flashes indicating the function is set.
Press the TEST key or START key to start paper folding. (When pressing the TEST key first, then the counter function is not effective, i.e, test sheets are not counted.)

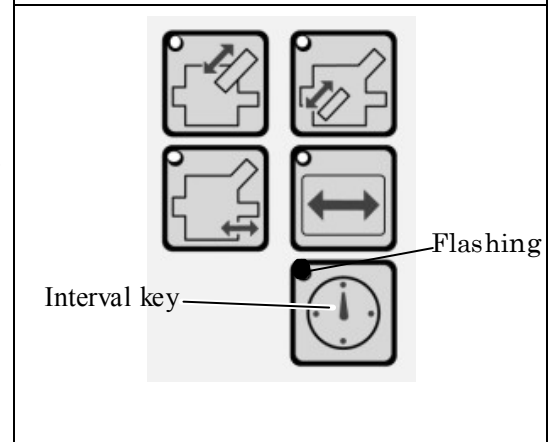

* How to clear Interval Mode

Press the Interval Key and press the Clear Key or input "0". Then, the interval function is cleared.

Example:

How to set 8 seconds as interval time and 50 sheets fold as number of sheets for interval operation.

By this setting, the machine will stop for 8 seconds after folding 50 sheets, and start folding again automatically.

How to set:

- Press the Interval key.
- The bar beside “SEC” flashes. Using the numerical key, input “8”.
- Press the Interval key.
- The bar right beside “SET” flashes. Using the numeral key, input “50”.
- Press the Interval key. The lamp on the Interval key flashes.
- Set the speed according to the paper quality and fold type.
- After setting, press the TEST key or START key to start folding.
- In case of making preset number of folds with the Interval function is set, input the desired preset number while the lamp on the Interval key is flashing. Then, the machine stops after the preset number of sheets of paper are processed.

Incidentally, when the dot below the units digit is lit, it shows that the preset value is input and valid.

When it is not lit, it is not valid and the machine continues to process until there is no paper loaded on the paper feed shelf.

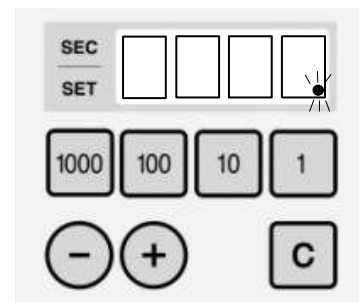

(8) Adjustment

(A) Fine Adjustment

Adjusting Table 1 or Table 2

Select the Stopper Move Mode key (Table 1 or 2). The lamp of the selected Stopper Move Mode key illuminates.

The present stopper position is shown on the [Counter].

In case of standard-size paper, the stopper moves automatically to the suitable position according to the paper size and fold type.

Apply this adjustment when fine adjustment is in need for the folding position.

Values input manually return to standard values if any one of other fold type keys is pressed.

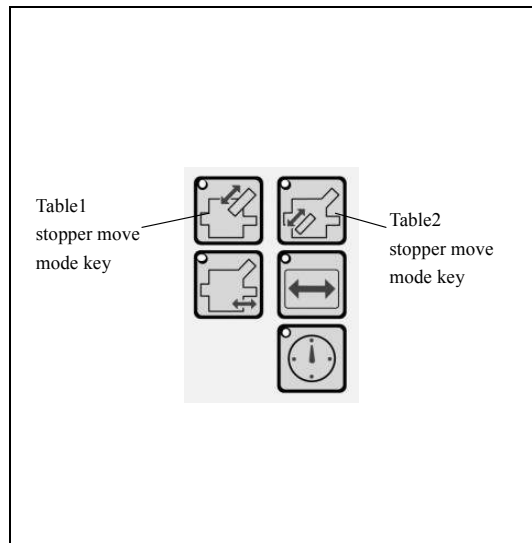

Press the +/- key and move the stopper to the desired position.

The value displayed to the [Counter] shows the position of the stopper. (Unit: inch)

Example: When display of the [Counter] is 11.38, the stopper position is 11.38 inch.

The position can be moved based on a unit of 0.003 inch. Note indicator shows lowest of 2nd digits from decimal point.

Press the Stopper Move Mode key (Table 1 or 2) again.

The lamp on the selected Stopper Move Mode key flashes. Regarding the adjustment, refer to the table of page 31.

The length of the arrow for each fold type is set based on the stopper position of Table 1 or 2.

Example, In case of Double Parallel,

Table 1: Fold a half of the overall length

Table 2: Fold one fourth of the overall length

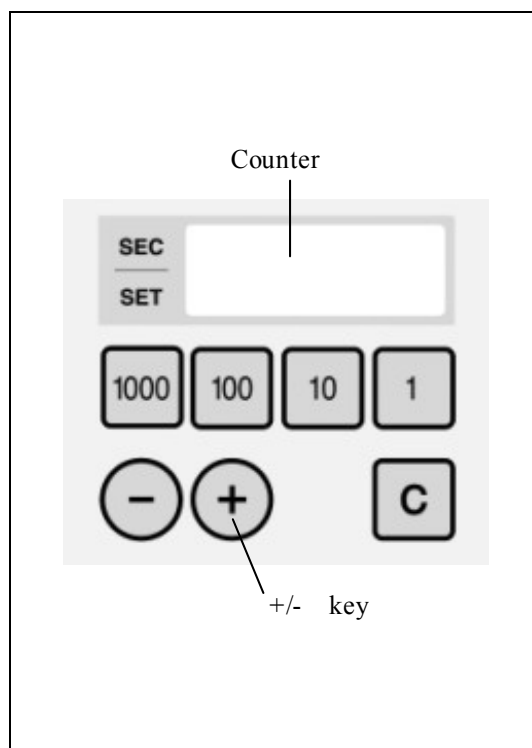

Note: To prevent damage to the Interceptor Push Bar at Stopper of Table 1, it does not come into contact with Interceptor when stopper is moved by manual mode to avoid enforced pushing.

With automatic mode only, it comes to contact with Interceptor to make by-pass the Table 1.

■ Indicates leading edge when paper is fed from feed tray.

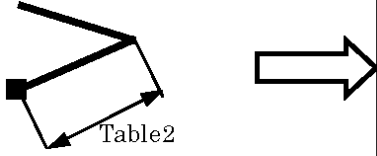
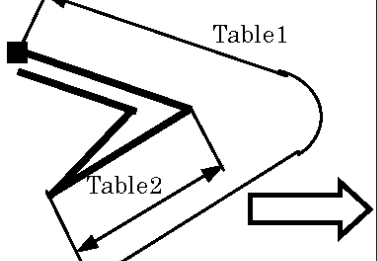
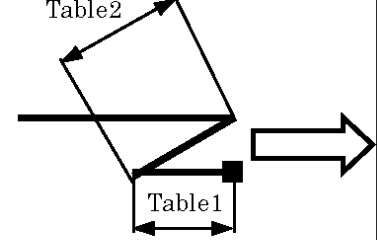
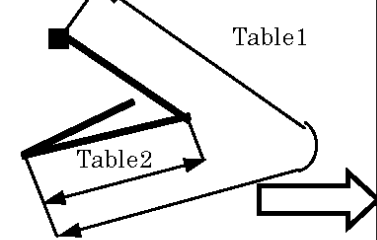
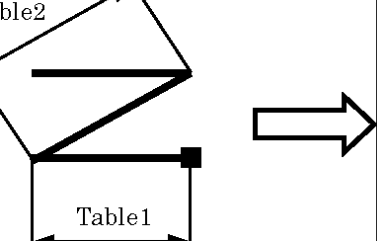
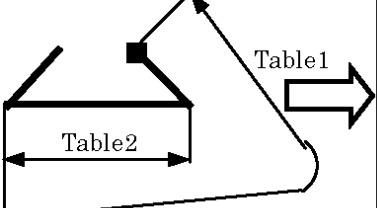
Fold Type		Table1	Table2
SINGLE		—	1/2
DOUBLE PARALLEL		1/2	1/4
FOLD-OUT		1/4	1/4
LETTER		2/3	1/3
ZIGZAG		1/3	1/3
GATE		3/4	1/2

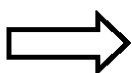
 Feed Out Direction of Folded Paper

Skew Adjustment by folding pattern

 Bold line indicates leading edge when paper is placed on feed tray.

 Shadow indicates upper surface when paper is on feed tray.

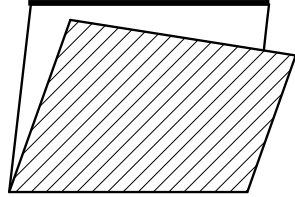
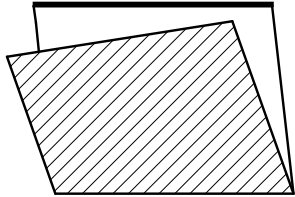
Fold Type	Single	
Skew		

For less than 34.31 lbs Bond

Feed Roller Direction Adj. Dial
(Less than 34.31 lbs Bond)



Turn Metallic Thumb Screw
Counterclockwise (-)



Turn Metallic Thumb Screw
Clockwise (+)



For more than 34.31 lbs Bond or Feed Roller Direct. Adj. Dial is not effective

Skew Adj. Knob
(More than 34.31 lbs Bond or Feed Roller Direct. Adj. Dial is not effective)



Turn Thumb Screw
Clockwise (-)



Turn Thumb Screw
Counterclockwise (+)

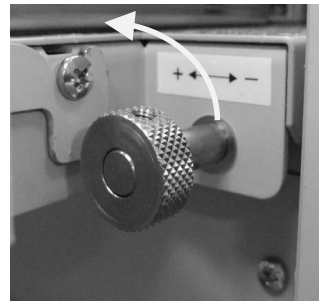

NOTE: Do not use, at the same time, Feed Roller Direction Dial and Skew Adjustment Knob unless really needed.

How stacked and folded

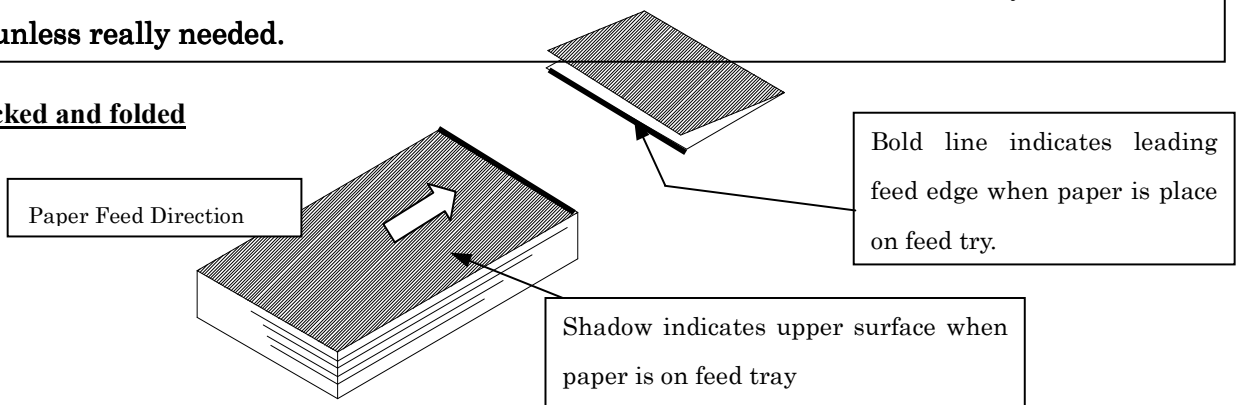



Paper Feed Direction

Bold line indicates leading feed edge when paper is placed on feed tray.

Shadow indicates upper surface when paper is on feed tray

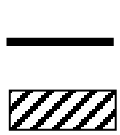
Skew Adjustment by folding pattern

Bold line indicates leading edge when paper is place on feed try.

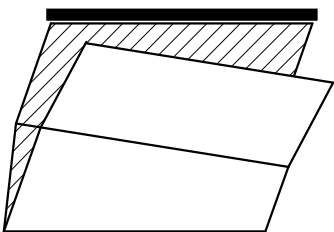
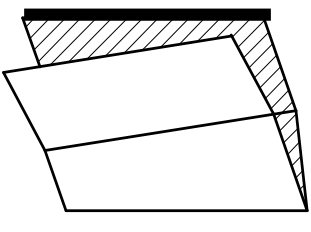
Shadow indicates upper surface when paper is on feed tray.

Fold Type	Double Parallel	
Skew		

For less than 34.31 lbs Bond

Feed Roller Direction Adj. Dial
(Less than 34.31 lbs Bond)



Turn Metallic Thumb Screw
Counterclockwise (-)



Turn Metallic Thumb Screw
Clockwise (+)



For more than 34.31 lbs Bond or Feed Roller Direct. Adjust. Dial is not effective

Skew Adj. Knob
(More than 34.31 lbs Bond or Feed Roller Direct. Adj. Dial is not effective)



Turn Thumb Screw
Clockwise (-)

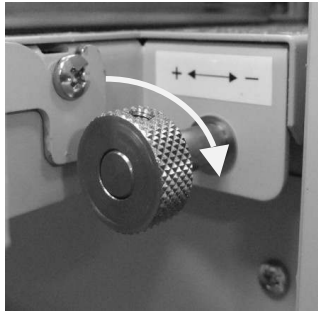

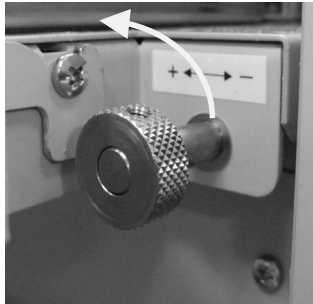

Turn Thumb Screw
Counterclockwise (+)

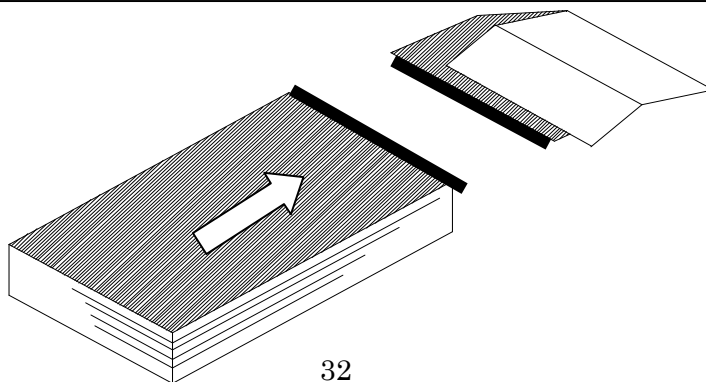

NOTE: Do not use, at the same time, Feed Roller Direction Dial and Skew Adjustment Knob unless really needed.



Skew Adjustment by folding pattern

 Bold line indicates leading edge when paper is place on feed try.
 Shadow indicates upper surface when paper is on feed tray.

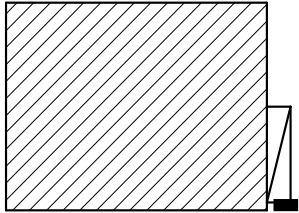
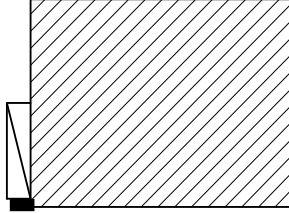
Fold Type	Fold-out	
Skew		

For less than 34.31 lbs Bond

Feed Roller Direction Adj. Dial
 (Less than 34.31 lbs Bond)



Turn Metallic Thumb Screw
 Counterclockwise (-)



Turn Metallic Thumb Screw
 Clockwise (+)



For more than 34.31 lbs Bond or Feed Roller Direct. Adjust. Dial is not effective

Skew Adj. Knob
 (More than 34.31 lbs Bond or Feed Roller Direct. Adj. Dial is not effective)



Turn Thumb Screw
 Clockwise (-)

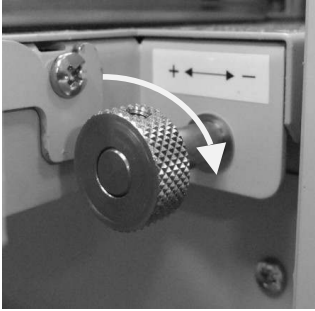

Turn Thumb Screw
 Counterclockwise (+)

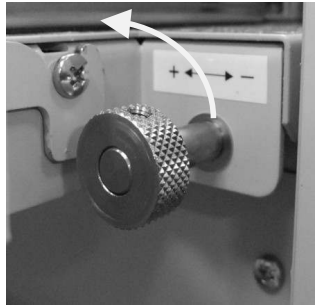

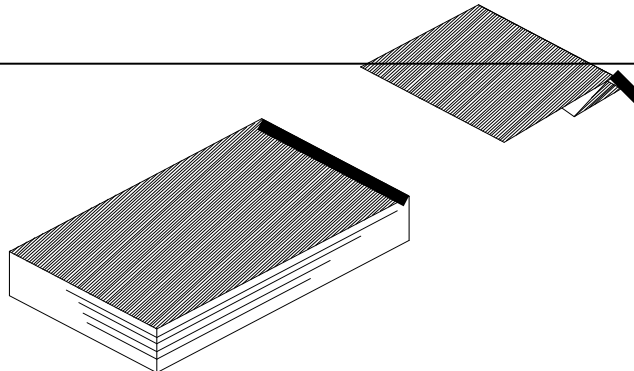

NOTE: Do not use, at the same time, Feed Roller Direction Dial and Skew Adjustment Knob unless really needed.

How stacked and folded

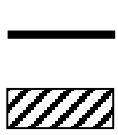

Skew Adjustment by folding pattern

Bold line indicates leading edge when paper is place on feed try.

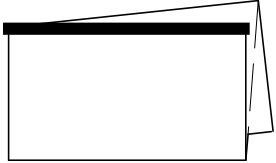
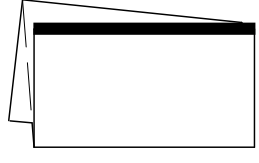
Shadow indicates upper surface when paper is on feed tray.

Fold Type	Letter	
Skew		

For less than 34.31 lbs Bond

Feed Roller Direction Adj. Dial
(Less than 34.31 lbs Bond)



Turn Metallic Thumb Screw Counterclockwise (-)



Turn Metallic Thumb Screw Clockwise (+)



For more than 34.31 lbs Bond or Feed Roller Direct. Adjust. Dial is not effective.

Skew Adj. Knob
(More than 34.31 lbs Bond or Feed Roller Direct. Adj. Dial is not effective)



Turn Thumb Screw Clockwise (-)



Turn Thumb Screw Counterclockwise (+)

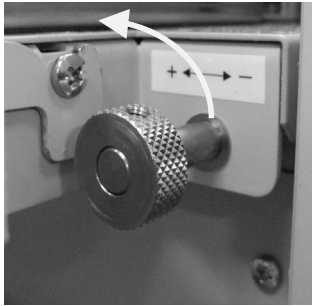



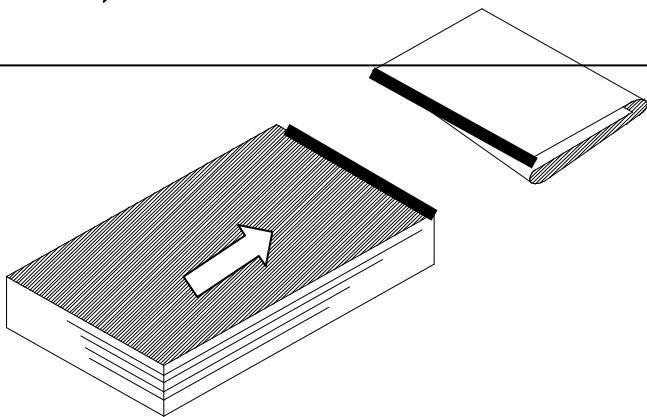

NOTE: Do not use, at the same time, Feed Roller Direction Dial and Skew Adjustment Knob unless really needed.

How stacked and folded

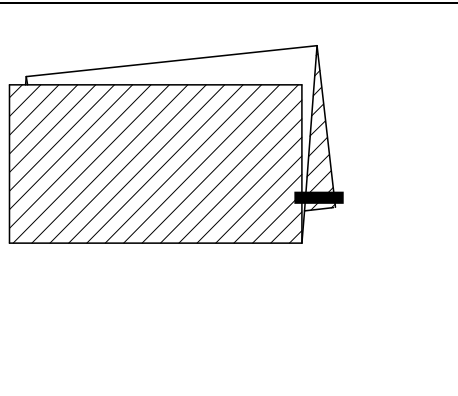
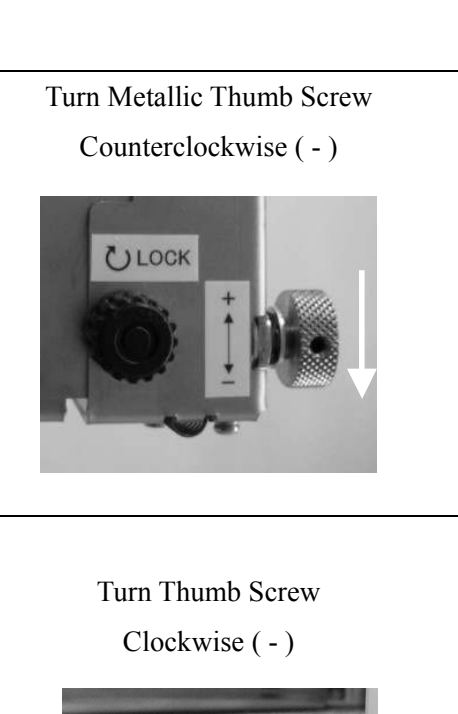
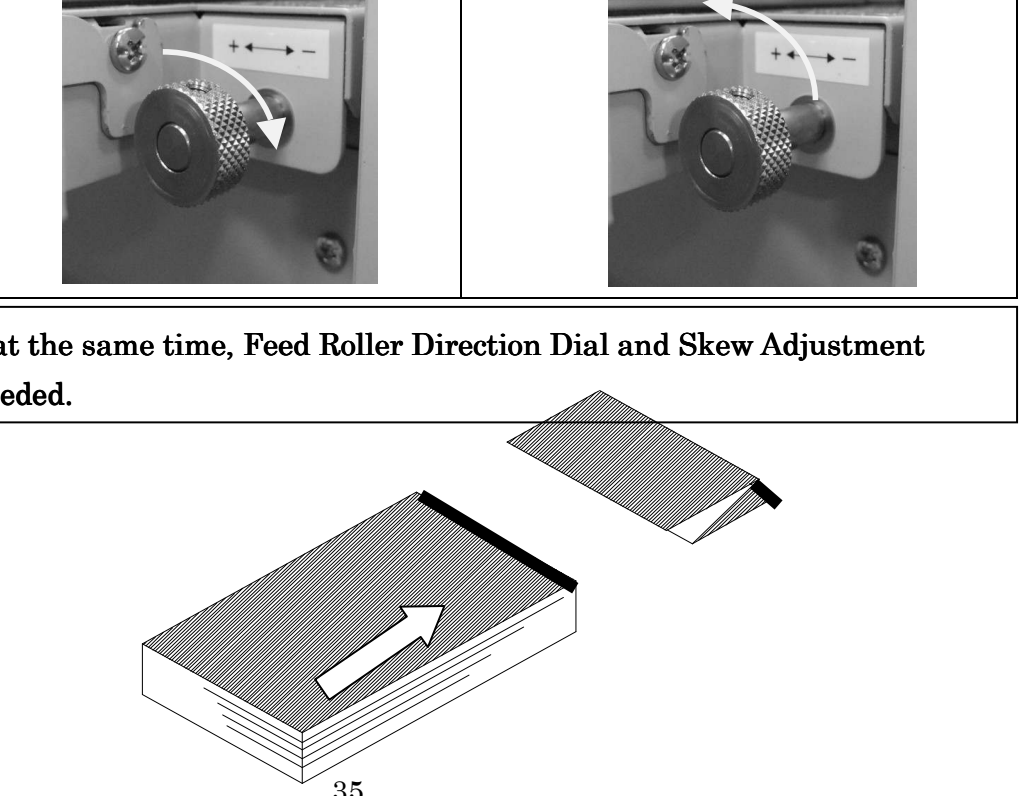
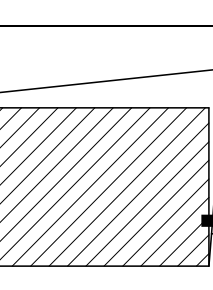

Skew Adjustment by folding pattern

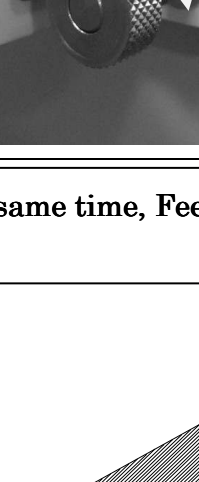
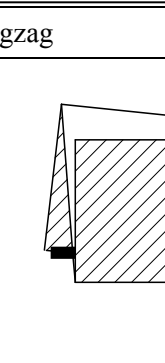
Bold line indicates leading edge when paper is place on feed try.
Shadow indicates upper surface when paper is on feed tray.

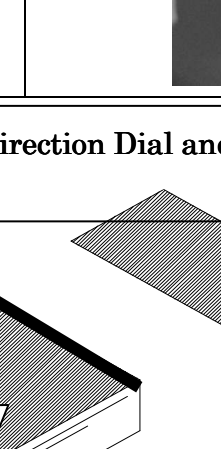

Fold Type	Zigzag	
<p>Skew</p> 		
<p>For less than 34.31 lbs Bond</p> <p>Feed Roller Direction Adj. Dial (Less than 34.31 lbs Bond)</p> 	<p>Turn Metallic Thumb Screw Counterclockwise (-)</p> 	<p>Turn Metallic Thumb Screw Clockwise (+)</p> 
<p>For more than 34.31 lbs Bond or Feed Roller Direct. Adj. Dial is not effective.</p> <p>Skew Adj. Knob (More than 34.31 lbs Bond or Feed Roller Direct. Adj. Dial is not effective)</p> 	<p>Turn Thumb Screw Clockwise (-)</p> 	<p>Turn Thumb Screw Counterclockwise (+)</p> 



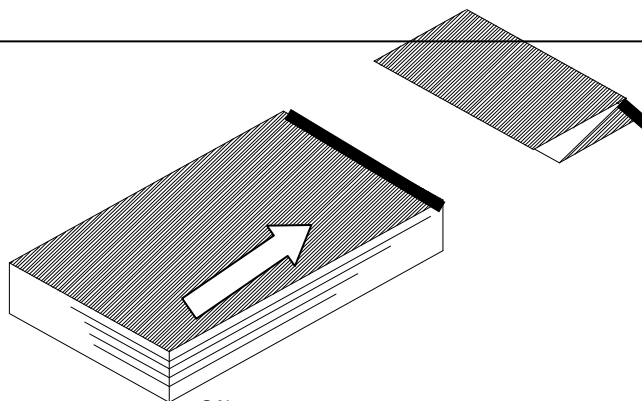



NOTE: Do not use, at the same time, Feed Roller Direction Dial and Skew Adjustment Knob unless really needed.

How stacked and folded

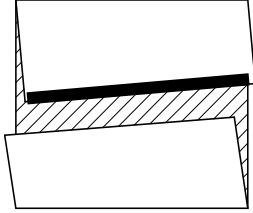
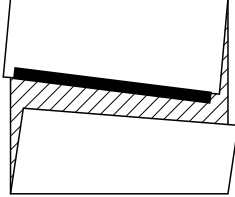

Skew Adjustment by folding pattern

 Bold line indicates leading edge when paper is placed on feed tray.
 Shadow indicates upper surface when paper is on feed tray.

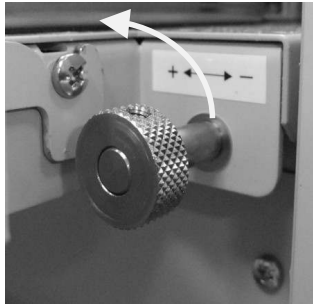
Fold Type	Gate	
Skew		
<p>For less than 34.31 lbs Bond</p> <p>Feed Roller Direction Adj. Dial (Less than 34.31 lbs Bond)</p> 	<p>Turn Metallic Thumb Screw Counterclockwise (-)</p> 	<p>Turn Metallic Thumb Screw Clockwise (+)</p> 
<p>For more than 34.31 lbs Bond or Feed Roller Direct. Adjust. Dial is not effective.</p> <p>Skew Adj. Knob (More than 34.31 lbs or Feed Roller Direct. Adj. Dial is not effective)</p> 	<p>Turn Thumb Screw Clockwise (-)</p> 	<p>Turn Thumb Screw Counterclockwise (+)</p> 

NOTE: Do not use, at the same time, Feed Roller Direction Dial and Skew Adjustment Knob unless really needed.

How stacked and folded

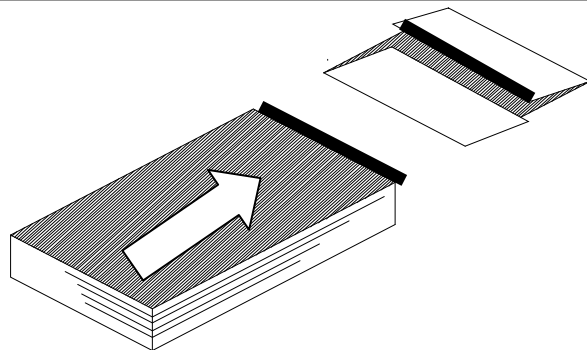

(C) Air Adjustment

[Air Blow Strength Adjustment]

The air blow strength can be adjusted by turning the air adjustment knob from low, per finer line, to high, per thicker line.

General information:

When double feed occurs, turn the air adjustment knob towards lower position slightly.

When paper is not fed, turn the air adjustment knob towards higher position slightly.

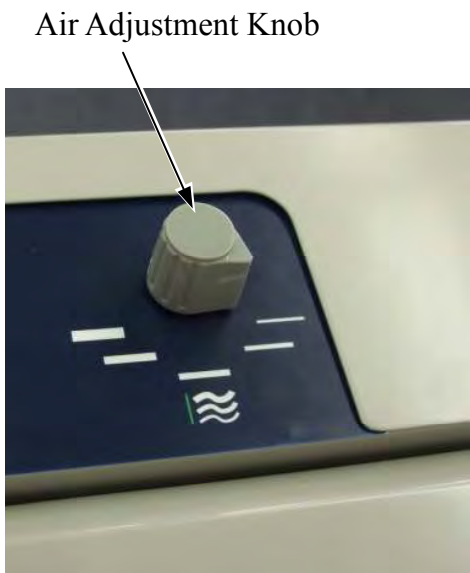

Note: Do not change position of Air Adjustment Knob extremely From the original position.

13. Press Test Mode Key for more than 2 seconds until buzzer sounds.
Then air starts to blow without feeding paper and Paper Feed Table Rises.

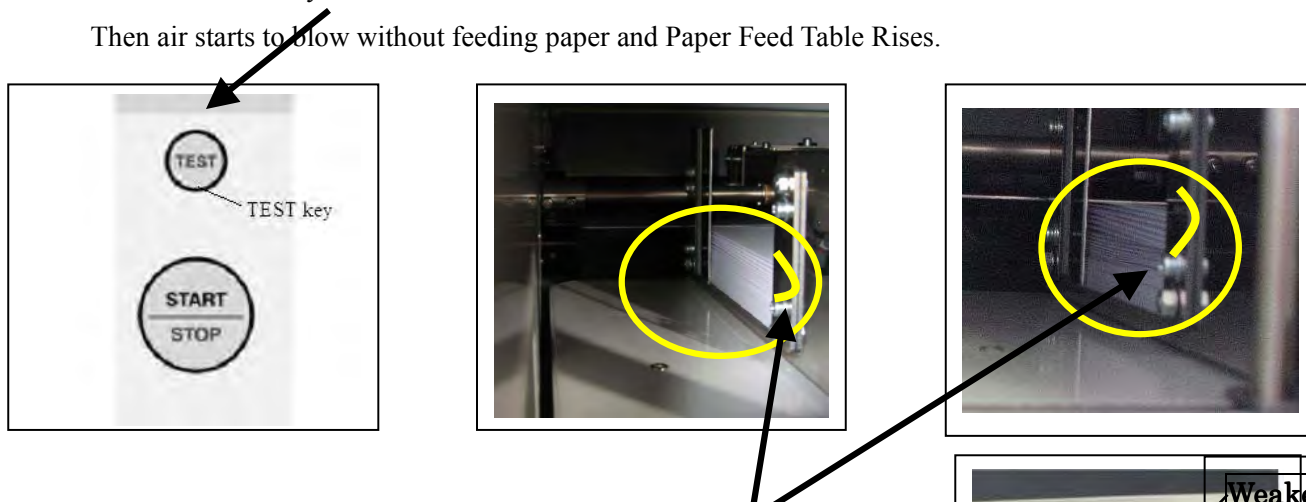

14. Adjust Air Blow Control Knob so as that the top 7 to 10 sheets flies in the air with stability/steadily and without sticking two sheet together. Dial is set more or less at fine line (week blow) as right picture.

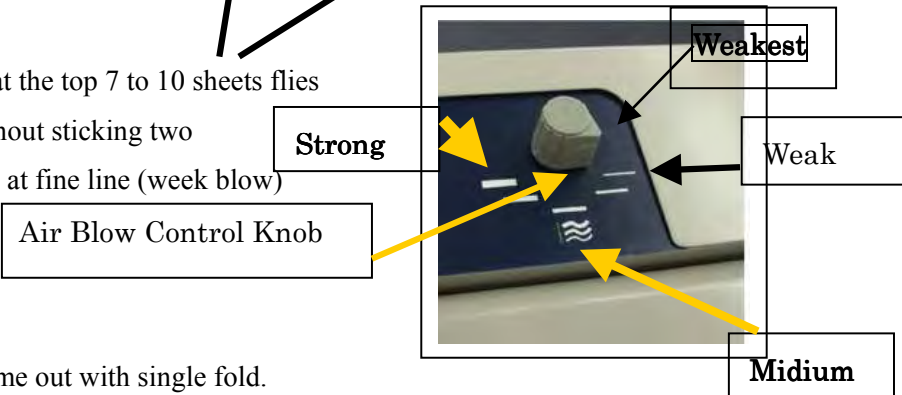

15. Press Test Key again and two sheets come out with single fold.

NOTE: (1) By pressing Test Key during blow test mode, machine test folds and automatically goes out of blow test mode.

(2) Or, by pressing START/STOP Key, blow test mode ends.

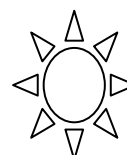

[Adjustment of Suction Air Strength]

When using thin papers like copy paper, double feed may tend to occur with stronger suction power.

Set Suction Strength Window at 4, i.e., opened fully.

Refer (E) at page 39.

The position of No. 0 is the closed condition of window, i.e., strongest suction by belt.

Suction Belt in effect can be switched between 3 rows and 2 rows, stronger and weaker suction respectfully.

Normally, 3 rows are used.

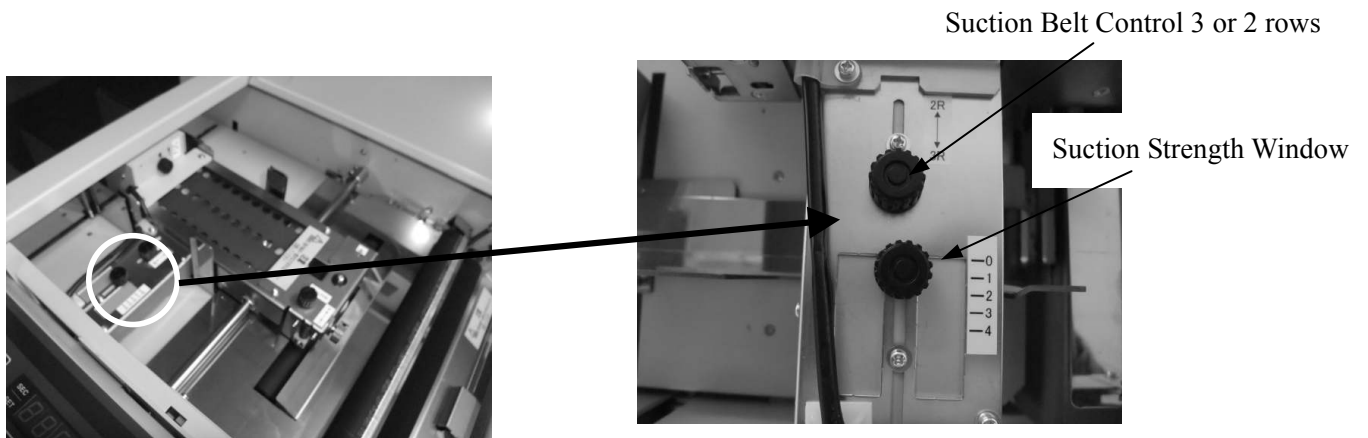

(D) Paper Height Adjustment

Adjust paper height by opening the top cover.

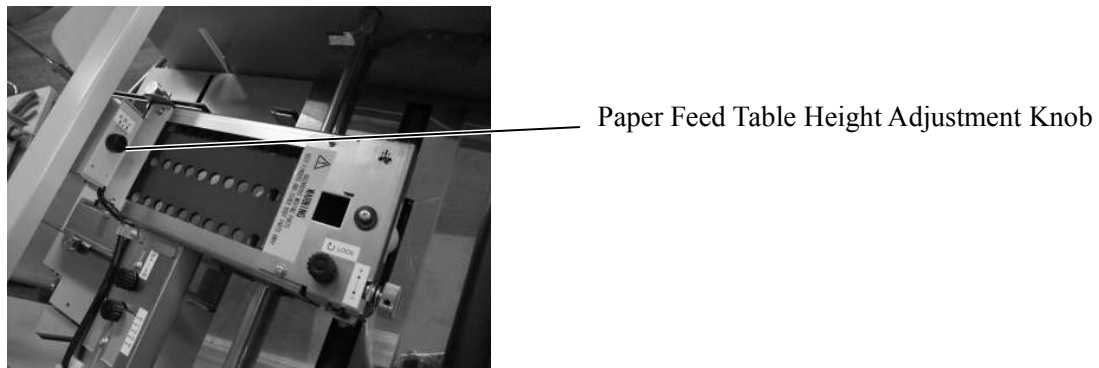

In case of adjusting the position of paper height according to the paper quality, loosen the paper feed table height adjustment knob and while holding the knob, set the point to “H”, “M” or “L”.

Recommended Position : Set to “H” side when paper cannot be sucked.

Set to “L” side when double feeding frequently occurs.

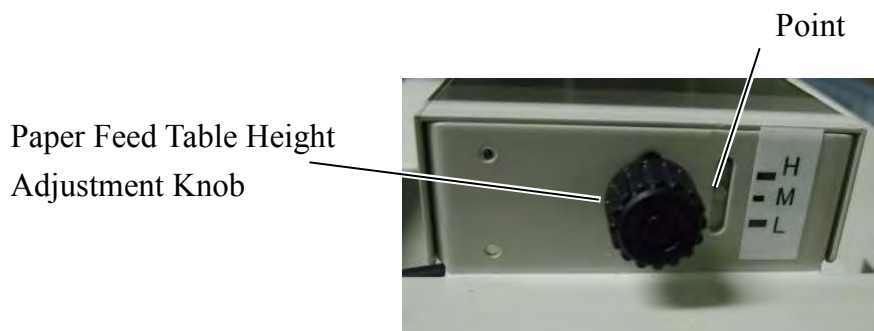

(E) Standard of Suction Air and Paper Feed Table Height

Adjustment of suction air and paper feed table height depend on paper quality, print condition or other environment. So **adjust them by referring to the following table as approximate guidance.**

		Blow Air (Air Adj. Knob, P37)	Paper Feed Table Height P38
A4	17.0 lbs Bond	Weakest	M
	70.9 lbs Coated Paper	Weak	M
	86.5 lbs Coated Paper	Weak	M-H
	106.1 lbs Coated Paper	Weak	H
A3	17.0 lbs Bond	Weakest	M
	70.9 lbs Coated Paper	Medium	M
	86.5 lbs Coated Paper	Midium	M-H
	106.1 lbs Coated paper	Midium	H

Refer Air Blow Adjustment (P37). Test Blow is always effective tool for adjustment.

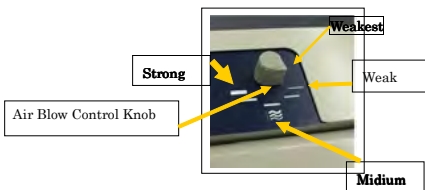

1. Offset Paper

Weight (lbs)	Suction Strength Window Opening	Suction Belt Row Control
Less than 17 lbs Bond	4	3R
17 thru 22 lbs Bond	2	3R
27.9 lbs Bond	0	3R

2. Coated Paper

Weight (lbs)	Suction Strength Window Opening
Less than 27.9 lbs Bond	4 3R (2R in case of double feed)
Over 27.9 lbs Bond	0 3R

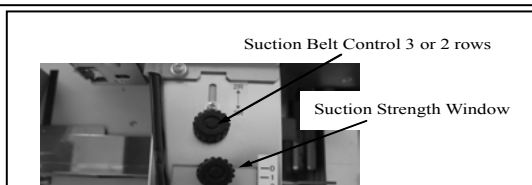

Do one of followings and see how it works. Do not make two adjustments at one time.

Frequent Double Feed	Suction Air is too strong	or	Top Paper Height, i.e., Paper Feed Table Height is too high
	Open Suction Window for one graduation		Lower 1/2 graduation
Frequent Empty Feed	Suction Air is too weak	or	Top Paper Height, i.e., Paper Feed Table Height is too low.
	Close Suction Window for one graduation		Rise 1/2 graduztion

(F) Separator Height Adjustment

When adjusting the separator height, turn the separator adjustment knob using a flathead screwdriver and adjust the height so that the tip of the separator rubber touches the paper feed belt.

If empty feed frequently occurs when thick paper is used, open about a 0.5mm space between the paper feed belt and separator rubber. Use several sheets of paper to be used for filler gauge.

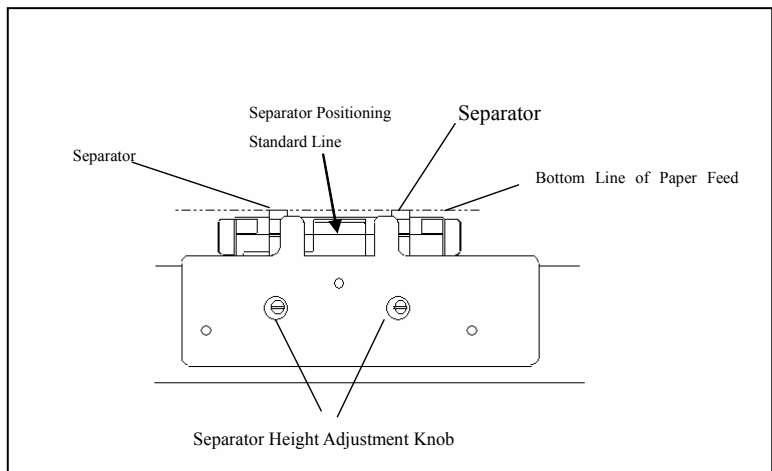

By turning the Separator Height Adjustment Knob clockwise, the separator raises to direction of paper feed belt. By turning the Separator Adjustment Knob counterclockwise, the separator comes down to opposite direction of paper feed belt.

G) Changing Location of Paper Ejection Roller

Roller automatically sets at the preset position as long as paper size is standard norm.

In case of out of standard norm paper, press Paper Ejection Roller Move Key. By pressing + or - Key, move the Roller and position where roller effectively works for specific folds. After position is selected, press Paper Ejection Roller Move Key again.

Depending folding speed and pattern, the Roller need to be relocated. Smaller numeral shows location of Roller closer to machine body.

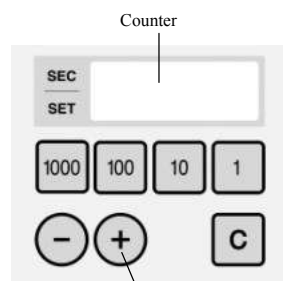
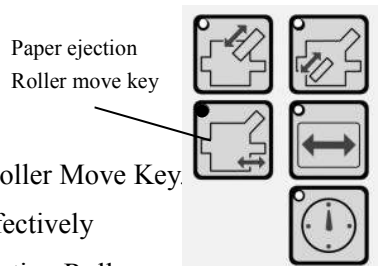

(9) Memory

(A) Fold Position Memory of Non-standard Papers

Memory of Non-standard folds can be input with the memory 1/2/3 keys and the fold type keys.

The positions of the stoppers of the Table 1 and 2, position of the ejection roller, and folding speed are all together saved in memory.

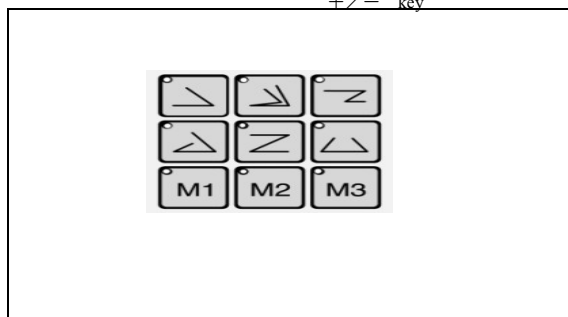

Select the Memory Key in which the fold will be input.
 Press the Store Key and release immediately when you hear a beep sounds.

The lamp of the key in which the fold has been memorized will flash. Memory remains storing specific setting
 Even main Power Switch is turned off, i.e., when Power Switch is turned on again, memorized pattern can be used again.

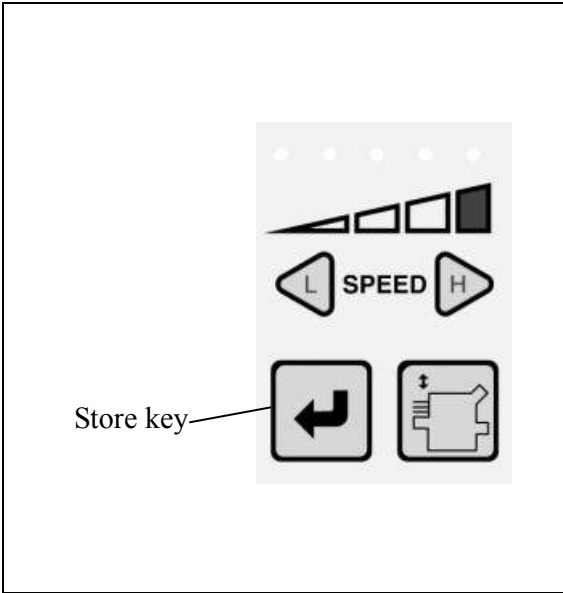

(B) Fold Position Memory of Standard Papers

When folding line(s) is not as desired for standard paper, the fold position after adjustment can be stored to the Fold Type key.

Memory of 18 kinds of setting is available as follows:

18 kinds of papers (Ledger, Legal and Letter) × 6 kinds of fold type keys

= 18 kinds of settings

Note: For each folding patter or one Memory Key, one

Each folding pattern can be stored.

Positions of stoppers of the Table 1 and 2, position of the ejection roller, and folding speed are all saved in memory.

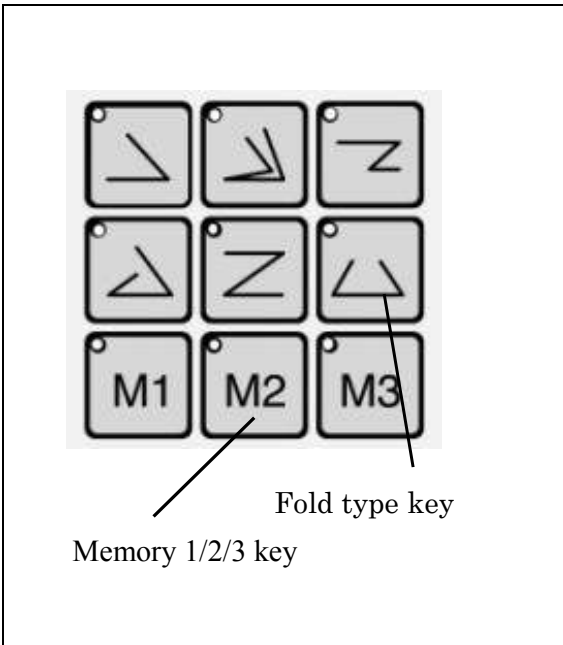

After adjustment of fold position folding line(s), press the Store Key. (Regarding the adjustment method, refer to Adjusting Table 1 or Table 2 of Page 26.)

Press Store Key and release immediately when you hear a beep sounds.

The lamp of the key in which the fold has been memorized will flash.

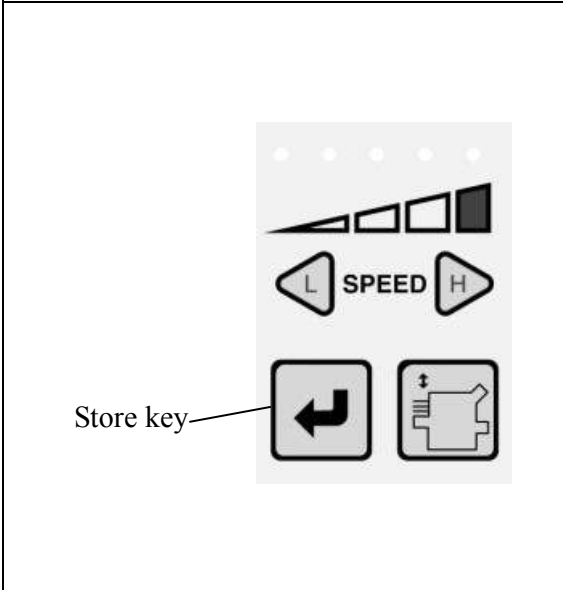

(C) Clearing Memory

Clear the storage input in the memory 1/2/3 keys and the fold type keys

Press first a desired Memory 1/2/3 Key or Fold Type Key being stored first and then keep pressing the C Key. Release immediately the C Key when you hear a beep sound.

The lamp of the key in which the storage has been cancelled will light.

Note:

The lamp of the key in which the fold pattern is stored flashes.

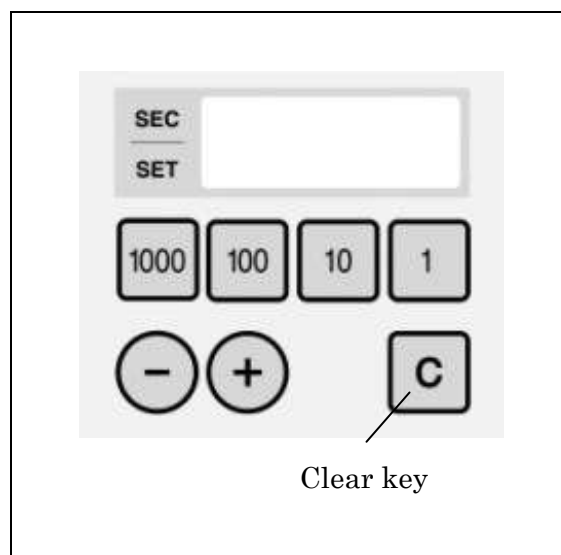

(D) Clearing all the memorized patterns

Turn off the power and while pressing the C Key, turn on the power.

Note:

All the stored pattern including custom fold you memorized is cleared. No chance to recall after cleared.

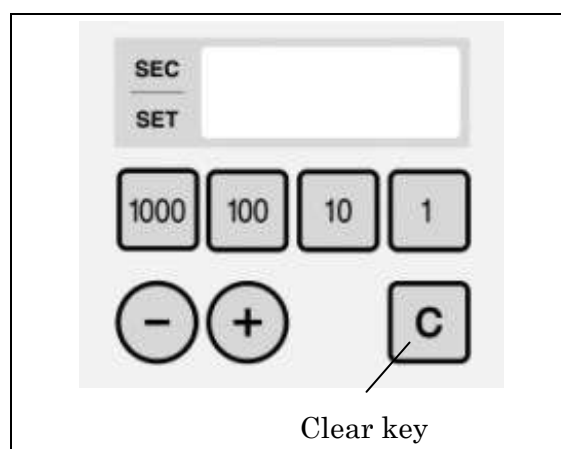

(10) Check Lamps, Error Codes and Troubles

If Check lamp (1) is flashing it may indicate:

- 1) No paper
- 2) The paper feed shelf does not work.
- 3) Failure of the paper height sensor
- 4) Empty feed
- 5) Excess loading of paper

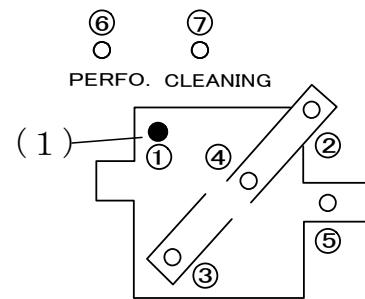

If Check lamp (2) is flashing it may indicate:

- 1) Improper setting of Table 1
- 2) Stopper lock of Table 1

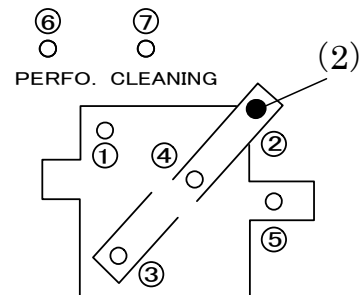

If Check lamp (3) is flashing it may indicate:

- 1) The electric plug of Table 2 is not inserted
- 2) Stopper lock of Table 2

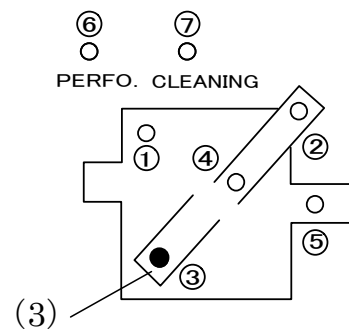

If Check lamp (4) is flashing it may indicate:

- 1) Paper Jam

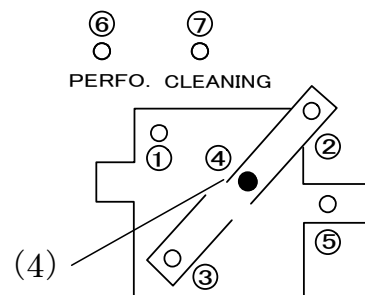

If Check lamp (5) is flashing it may indicate:

- 1) The electric plug of the paper ejection unit is not inserted
- 2) Ejected paper is full
- 3) Ejected paper jam
- 4) Paper ejection sensor is dirty dust or ink

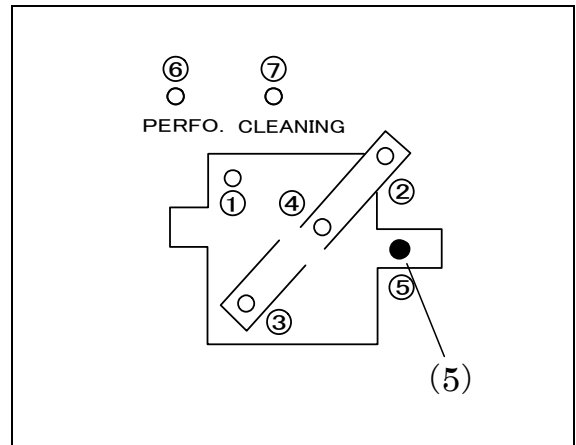

If Check lamp (6) is lit, it may indicate:

Perforator(Option) is installed

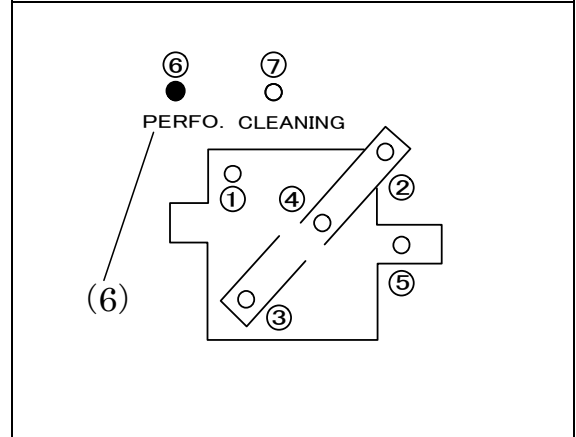

If Check lamp (7) is lit, it may indicate:

It lights after every 10,000 sheets of paper folded.

- For reset, turn on the machine while pressing – Key.
- You can disable this function when you turn on the machine keep pushing [single (Fold type)] key.
- You can activate this function again when you turn on the machine with [gate(Fold type)] key pushed.

Clean the belt as frequently as needed depend on the printing condition and paper quality before the cleaning lamp is lit.

Regarding the cleaning method, refer to Cleaning of Sensors of page 47 and Cleaning of Fold Roller/Paper Feed Belt of Page 48.

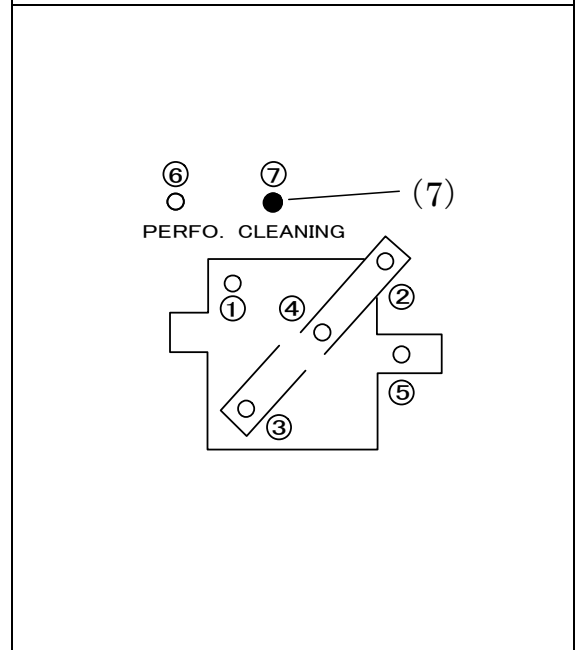

Note:

If paper is loaded immediately after printing, problems such as jamming, double feed, slipping, and wrinkling may occur. Make sure that the printing ink is completely dry, statics are gone and paper is well fanned out before loading.

If the machine is placed in the vicinity of a fluorescent lamp and it operates irregularly, the paper size detection sensor may not be functioning properly because of light from the fluorescent lamp.

In such a case, place the machine farther from the fluorescent lamp.

For each error symptom, the following error code will be displayed.

Error code	Symptom
E-01	No paper
E-02	Neither Table 1 nor the perforating/scoring unit is installed to the position of Table 1 unit.
E-03	Paper left in the paper ejection sensor unit, or the paper ejection sensor is dirty.
E-04	Internal paper jam
E-05	Ejected paper jam
E-06	Excess loading of paper
E-07	Sensors require cleaning or rollers require cleaning.
E-08	Paper ejection table connector is not connected.
E-09	Empty feed
E-10	Table 2 is not installed
E-11	Remove the paper ejection table to use perforator unit.
E-51	The door of the Table 2 is open, or the top cover is open
E-52	Paper left in the paper feed sensor unit, or the paper feed sensor is dirty.
E-53	Failure of the paper height sensor.
E-54	Failure of the feed table up and down motor
E-55	Failure of the main motor, or the encoder is dirty
E-56	The paper ejection roller is locked, or the motor is disconnected, or the home position micro SW for ejection roller is disconnected or dislocated.
E-57	The table 1 stopper is locked, or the motor is disconnected, or the sensor is disconnected.
E-58	The table 2 stopper is locked, or the motor is disconnected, or the sensor is disconnected.

Note: To clear Error Code, press C Key after cause of trouble is eliminated.

(11) Troubleshooting and Cleaning

CUTION: Make sure to disconnect power cable before starting the troubleshooting.

(A) Troubleshooting of Paper jam

Remove the Table-1 and remove the paper or pieces of paper.

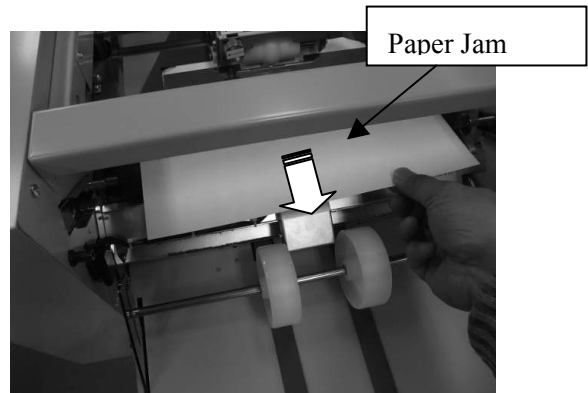
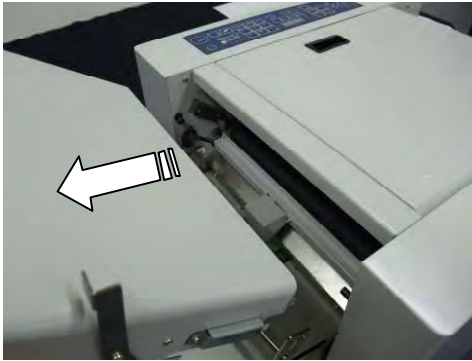

Open the table-2 door, remove the Table-2 and remove the paper or torn pieces of paper.

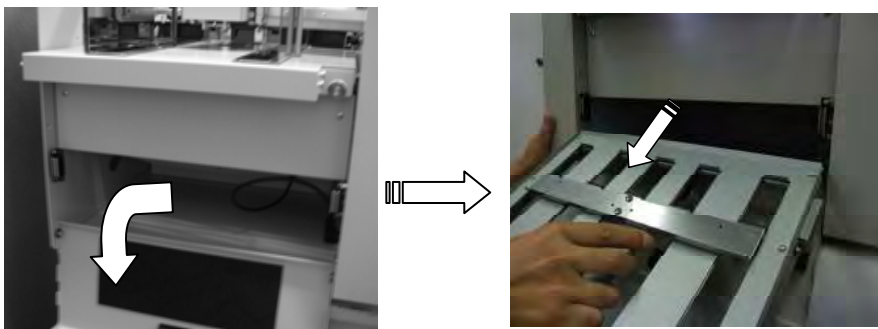

When paper jammed using less than **27.9 lbs Bond** paper, eject jammed paper by force as follows:
(In case paper cannot be ejected by this method, remove jammed paper manually per the above steps.)

- (1) By pressing the Plus Key for a while, the motor starts to rotate and paper in the folding rollers is ejected.
- (2) By pressing the Plus Key further, the fold stopper moves towards the closest position of folding rollers and jammed paper in the fold table is ejected.

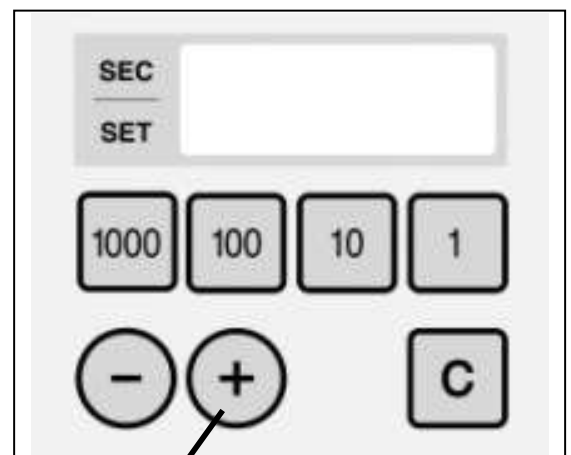

Plus key

(B) Cleaning of Sensors

Excercise cleaning each sensor periodically.

- (1) Open the top cover and remove paper powder or dust by cotton swab, etc. from the window
Circled position as shown in the following figure.



- (2) Clean the paper eject sensor (circled position as shown in the following figure) by cotton Q-tips, etc.

(The paper eject sensor is emitter/receiver photo cells. Clean both upper and lower photo cells. Especially lower photo cell tends to get dust accumulated.

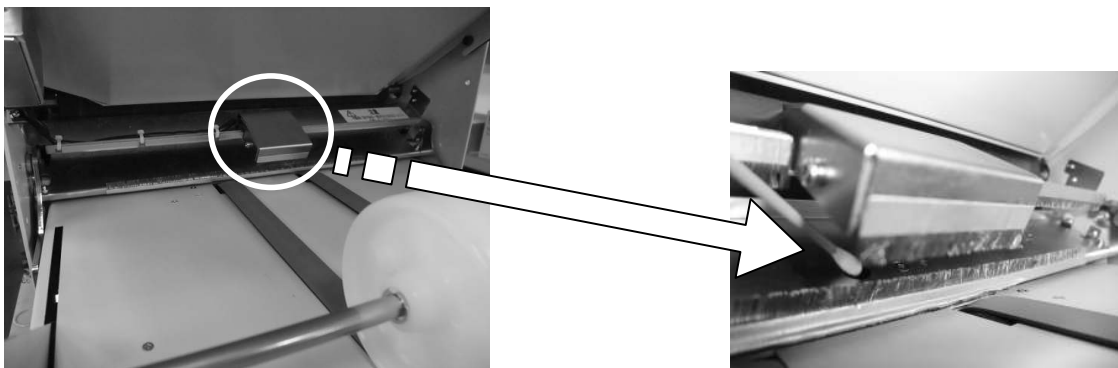

- (3) Clean the paper detection sensor by Q-tips. Locations of photocell on the Paper Feed Table are circled.

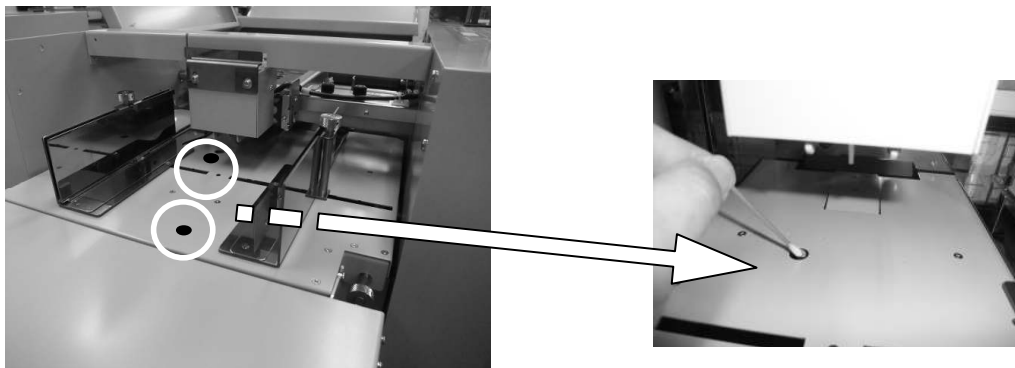

(C) Cleaning of Fold Roller and Paper Feed Belt

When paper feed slips, folding line does not match as desired, wrinkled paper or inner paper jam occur frequently, it may be caused from paper dust or ink accumulation.

Clean the fold roller as shown in the below figures.

Open the top cover, remove the Table 1 and clean each Folding Roller and Paper Feed Belt.

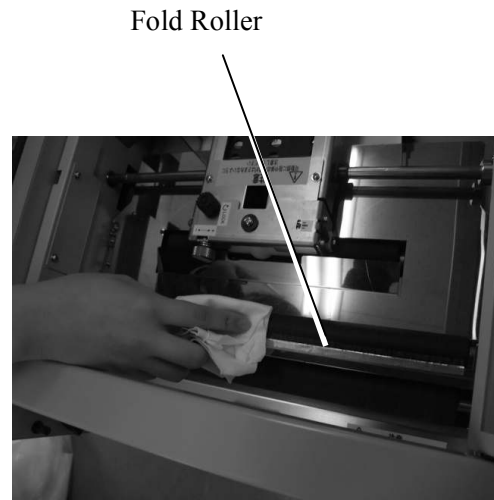
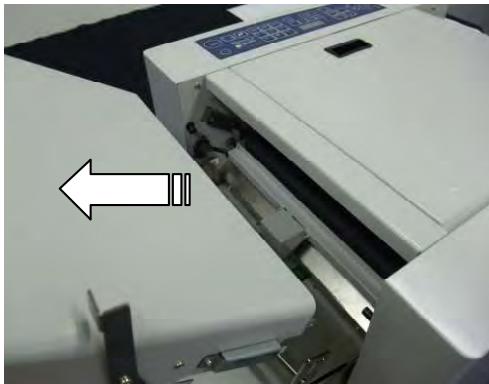

To clean Rollers located inside machine, remove paper stack on the Paper Feed Table and move the Paper Feed Table to the highest position.

Open Table-2 cover and remove the Table 2. Clean the folding roller installed in the depth of machine body.

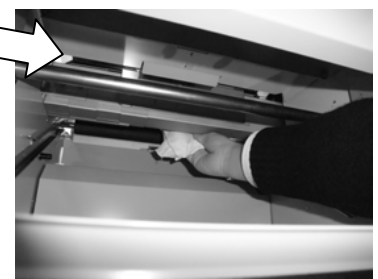
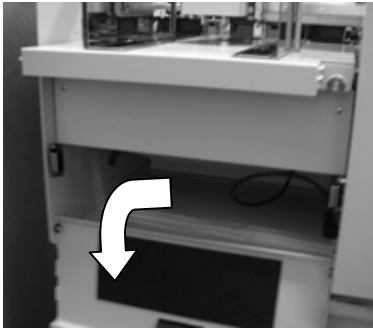

Open the top cover and clean the paper feed belt.

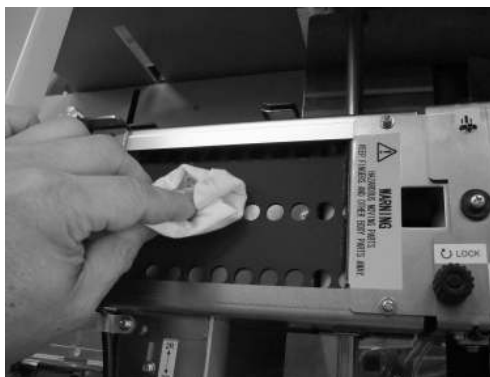

MEMO

MEMO

