

MBM Aerocut Air Feed Paper Slitter-Cutter-Creaser

Instruction Manual



Provided by

MyBinding.com

When Image Matters.

Call Us at 1-800-944-4573

UCHIDA

AeroCut

CUTTER & CREASER

OPERATION MANUAL

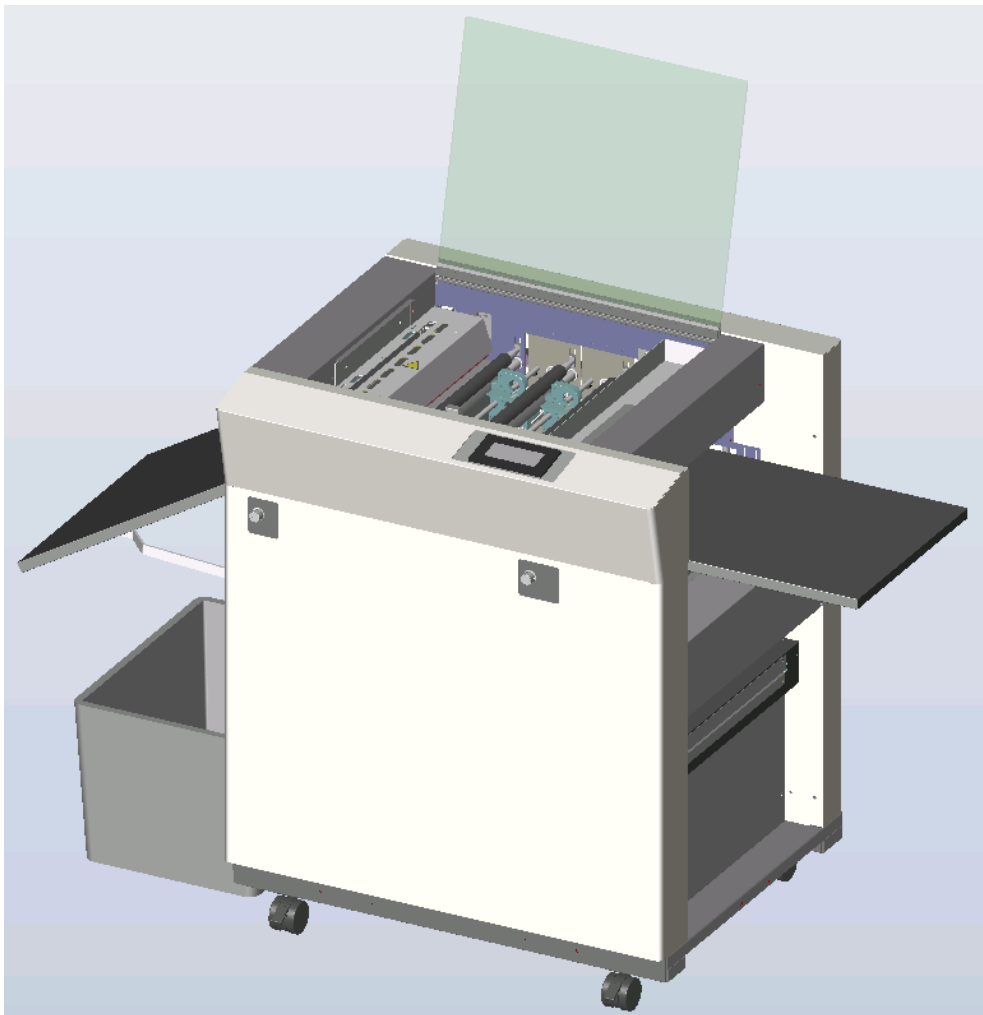

UCHIDA YOKO CO., LTD., TOKYO, JAPAN

Jul 14, 2011 USA

- Use machine only after reading the "Safety Instructions" given below carefully.
- These safety instructions are given to ensure that the machine will be used safely and properly and to prevent operators from sustaining harm and injuries.

Definition of Symbols and Notes

In this manual the following names and signs stand for possible dangers.



Danger

This symbol stands for immediate danger threatening the life and health of persons. Disregarding these instructions may cause severe damage to health and even serious injuries.



Caution

This symbol stands for an endangering situation that may occur. Disregarding these instructions may lead to slight injuries or damage to property.



Note

This symbol stands for notes, operational hints, and other useful information.

They are convenient for exploiting the machine's functional abilities.

SAFETY INSTRUCTIONS

Explanations of the illustrations used in the Safety Instructions are given as follows:

	<h3>Danger</h3>
<ol style="list-style-type: none">1. Don't open the cover of the equipment. There is a danger of receiving an injury or electric shock.2. Turn off the power supply beforehand when attaching or detaching the perforating blade. There is a danger of receiving an injury.3. Don't touch any rotating part. There is a danger of receiving an injury.	



Caution

1. Don't put a hand into the cover or a clearance between parts. There is a danger of receiving an injury.
2. Don't bring a hand, face, hair, sleeves of clothes and the like close to the rotating parts of the machine. There is a danger of receiving an injury.
3. Don't touch the blade point of the cutter. There is a danger of receiving an injury.
4. Don't touch the blade point of the perforating blade. There is a danger of receiving an injury.
5. Turn off the power supply beforehand when setting the feed table.
There is a danger of receiving an injury.
6. Turn off the power supply beforehand when setting the stacker. There is a danger of receiving an injury.
7. Turn off the power supply beforehand when setting the waste bin. There is a danger of receiving an injury.
8. Turn off the power supply beforehand when removing paper scraps. There is a danger of receiving an injury.
9. Avoid the combined use of the creaser and the perforator, as it may cause a paper jam or a mechanical failure.
10. For the perforator, papers of weight 65 lbs (Cover stock) [176 g/m²] or less is to be used. Using heavier paper may cause a paper jam or mechanical failure.
11. Do not exceed the MAX level when stacking the paper. Exceeding it may cause a mechanical failure.
12. Turn off the power supply beforehand when starting maintenance or inspection. There is a danger of receiving an injury.
13. When you install a machine, please install to a place with no dust, and the place which is not influenced with a liquid. It becomes the cause of failure if the installation method is mistaken.
14. When you put a machine into operation, please change into the state where all covers were closed. If it works where a cover is opened, there is fear of an injury.

Introduction

Read this "Operation Manual" carefully before use. In particular, be sure to read "Safety Instructions" (page 2 to page 3) to ensure that the machine will be used properly.

Keep the manual at an appointed place with care so that it may be accessible whenever necessary.



The specifications of this product are subject to change for improvement. Therefore, don't mistake the "Operation Manual" of one product of the same model for that of another because descriptions in the "Operation Manual" of products of the same model may differ.

Contents

1. Before use.....	6
(1) Description and quantities of accessories	6
(2) Exterior features	7
(3) Installation	9
2. Operating instructions	1 1
(1) Checks before use	1 1
(2) Setting of stacker.....	1 1
(3) Waste box setting.....	1 2
(4) How to attach the business card stacker.	1 2
(5) Paper setting	1 3
(6) Paper slant adjustment.....	1 4
(7) Crease depth adjustment	1 4
(8) How to attach the perforator	1 5
(9) How to adjust the perforation location	1 6
(10)How to adjust the depth of perforation.....	1 7
3. Operational method.....	1 8
(1) Basic operation.....	1 8
(2) Slitter initial location movement.....	1 8
(3) Format selection.....	1 9
(4) Free entry	2 1
(5) User program retrieval.....	2 1
(6) User program registration.....	2 2
(7) Setting of slitter and feed table	2 3
(8) Operation number cancellation.....	2 3
(9) Manual operation.....	2 4
(10) Speed change	2 5
(11) Cut mark on/off selection	2 6
(12) Automatic operation.....	2 6
4. Instructions for use	2 7
(1) If the machine stops during operation	2 7
(2) If Paper scrap remains on the machine.....	2 8
(3) Details concerning errors.....	2 9
(4) If the cut measurement does not match the input value	3 4
5. Product specifications	3 5
6. Equipment, Electric circuit and parts	3 7
7. Ordering consumables, etc.	4 0

1. Before use

(1) Description and quantities of accessories

Electric power cord	1pc.	
Hexagonal wrench	0.08" X 1pc.	
Tweezers	1pc.	
Waste ejector	1pc.	
Instruction manual	1pc.	
Waste box	1pc.	
Paper guide (Large)	1pc.	
Paper guide (Small)	5pc.	

(2) Exterior features

1. Name of parts

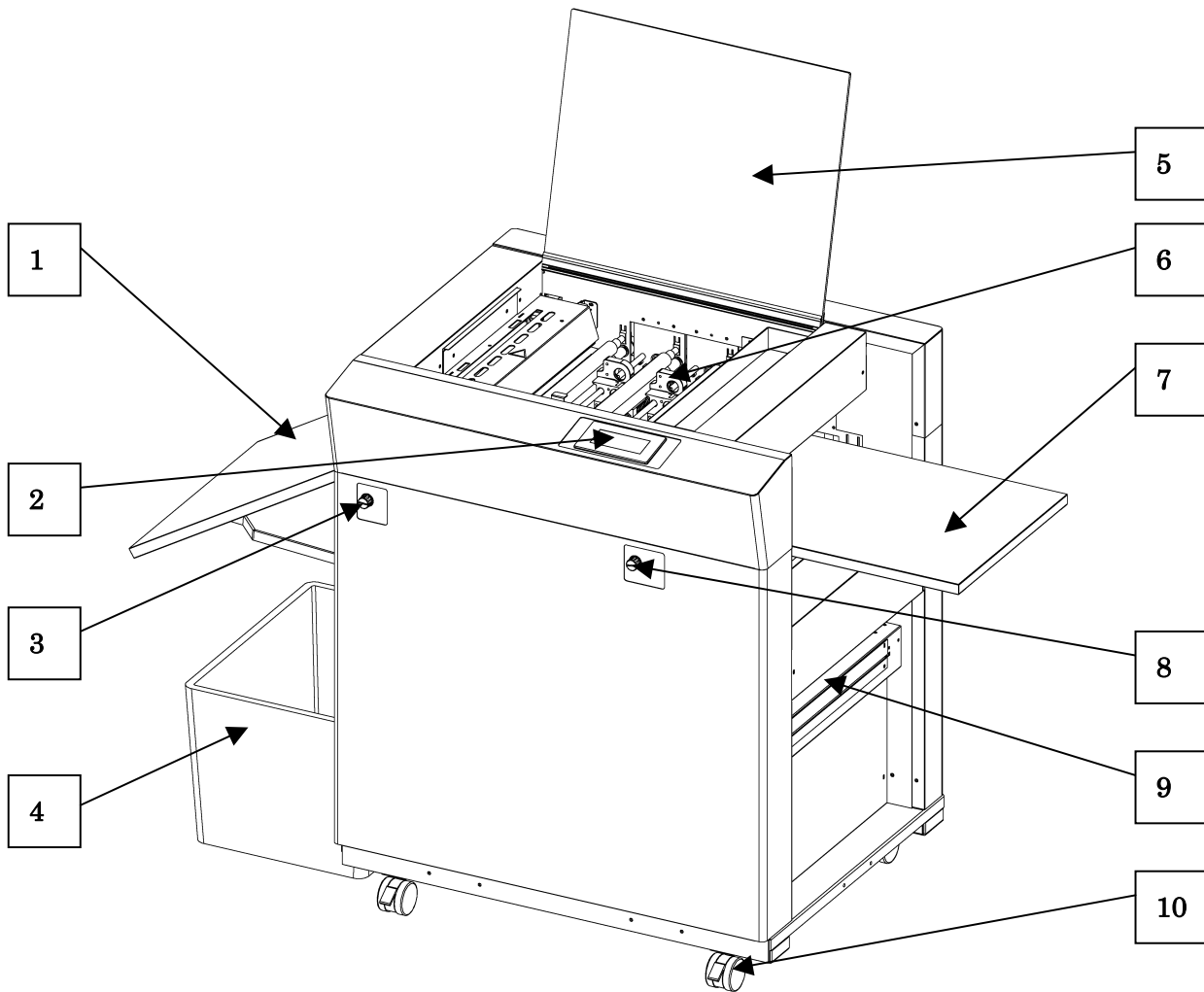

1. Stacker	6. Slitter
2. Touch Panel	7. Feed Table
3. Crease Depth Adjustment Dial	8. Slant Adjustment Dial
4. Waste Box	9. Perforator
5. Safety Cover	10. Caster

2. Electric-power-related points

The electric power switch and the inlet are located inside the machine, below the feed table.

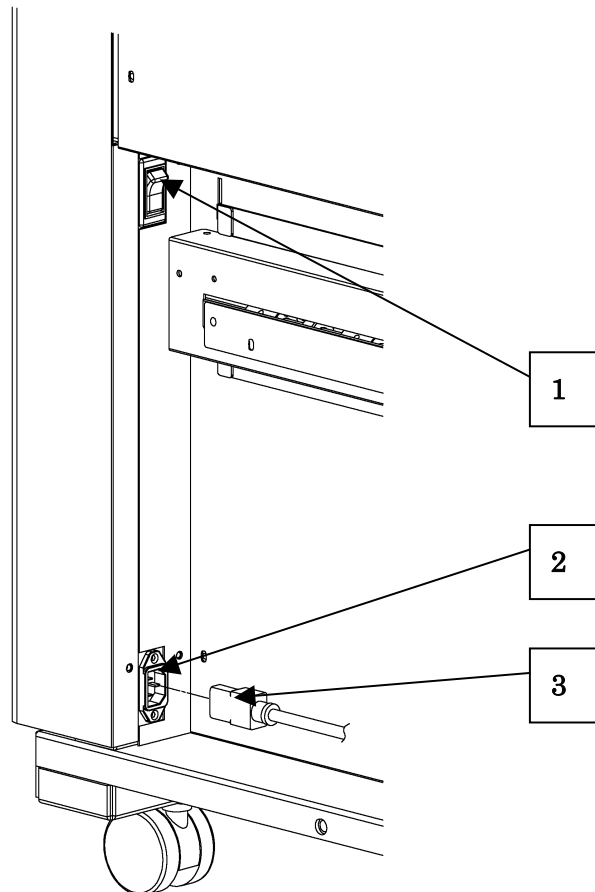



1	Power switch	① When it is set at "I", the power is turned on. ② When it is set at "O", the power is turned off.
2	Inlet	Plug in the electric power cord here.
3	Electric Power Cord	Plug this to the inlet.

(3) Installation

1. The machine installation method

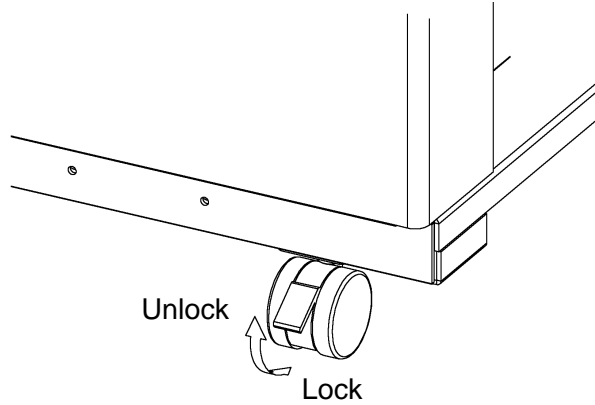
Please be sure to LOCK a caster brake after making it move to the target position, when installing a machine.



 Caution	
	When you install a machine, please install to a place with no dust, and the place which is not influenced with a liquid. It becomes the cause of failure if the installation method is mistaken.

2. Setting of feed table

Insert the feed table to the paper feeder, and set the feed table's slotted holes onto the protruding bolts on the machine. Install the 2 screws as shown below.

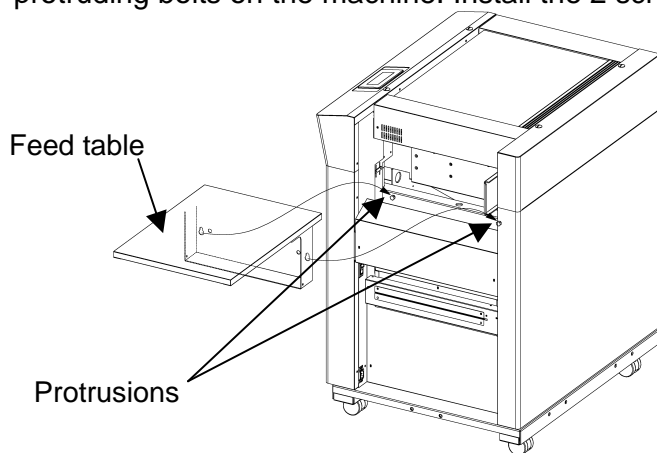

Screws
(M6x10)

3. How to remove accessories

- ① Remove the chute screws.
- ② Lift the chute and take out the waste box.
- ③ The accessory case is inside the waste box.

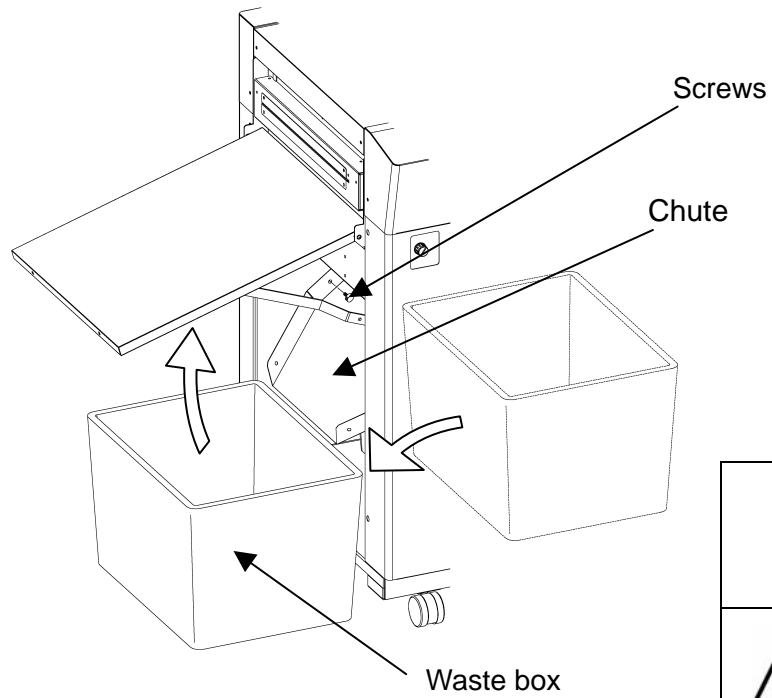

Caution



Power it off. Otherwise,
Injury could occur.

2. Operating instructions

(1) Checks before use



Check the following before operation. 

- ① Is the electric power turned off?
- ② Is the feed table set?
- ③ Is the stacker set ?
- ④ Is the electric power cord plugged in?
- ⑤ Is the waste box set?

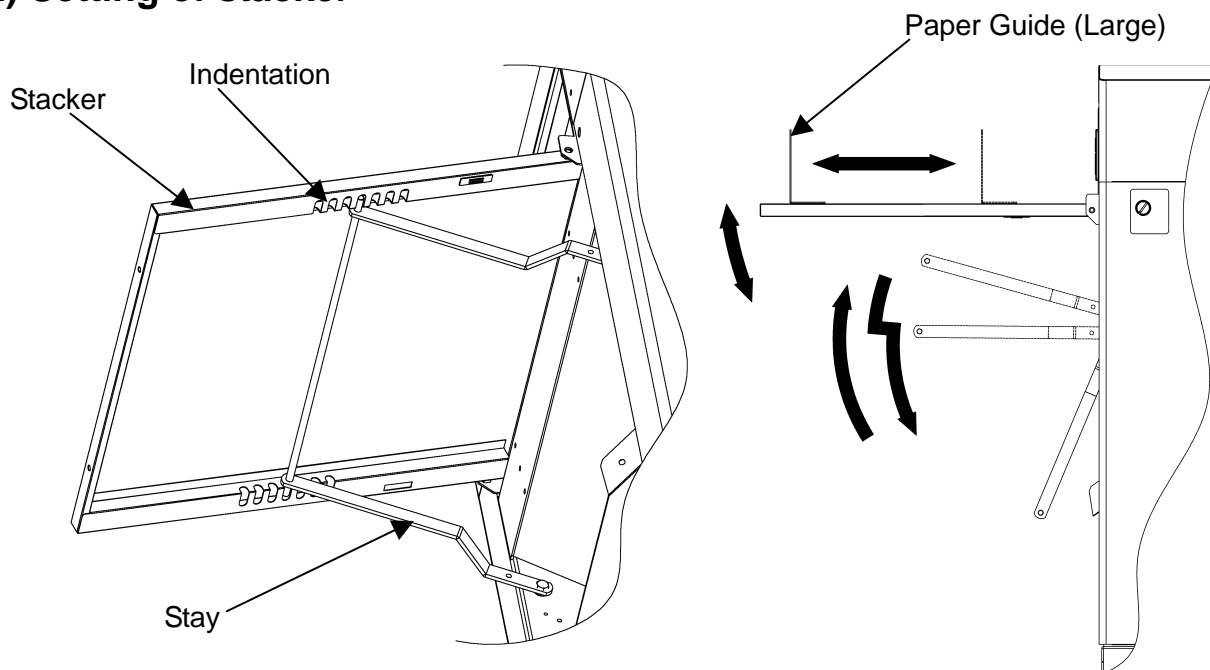
(2) Setting of stacker



- ① Open the stacker and set the stays in the indentation of the back of the stacker at an appropriate angle to allow smooth paper ejection.
- ② Adjust the large paper guide according to the paper size.

 Caution	
	Power it off. Otherwise, Injury could occur.

(3) Waste box setting

- ① Set the waste box under the stacker.

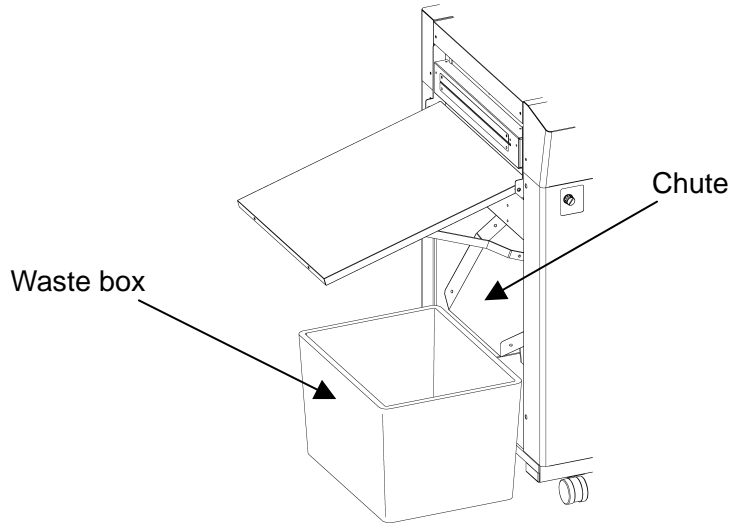

 Caution	
	Power it off. Otherwise, Injury could occur.

(4) How to attach the business card stacker.

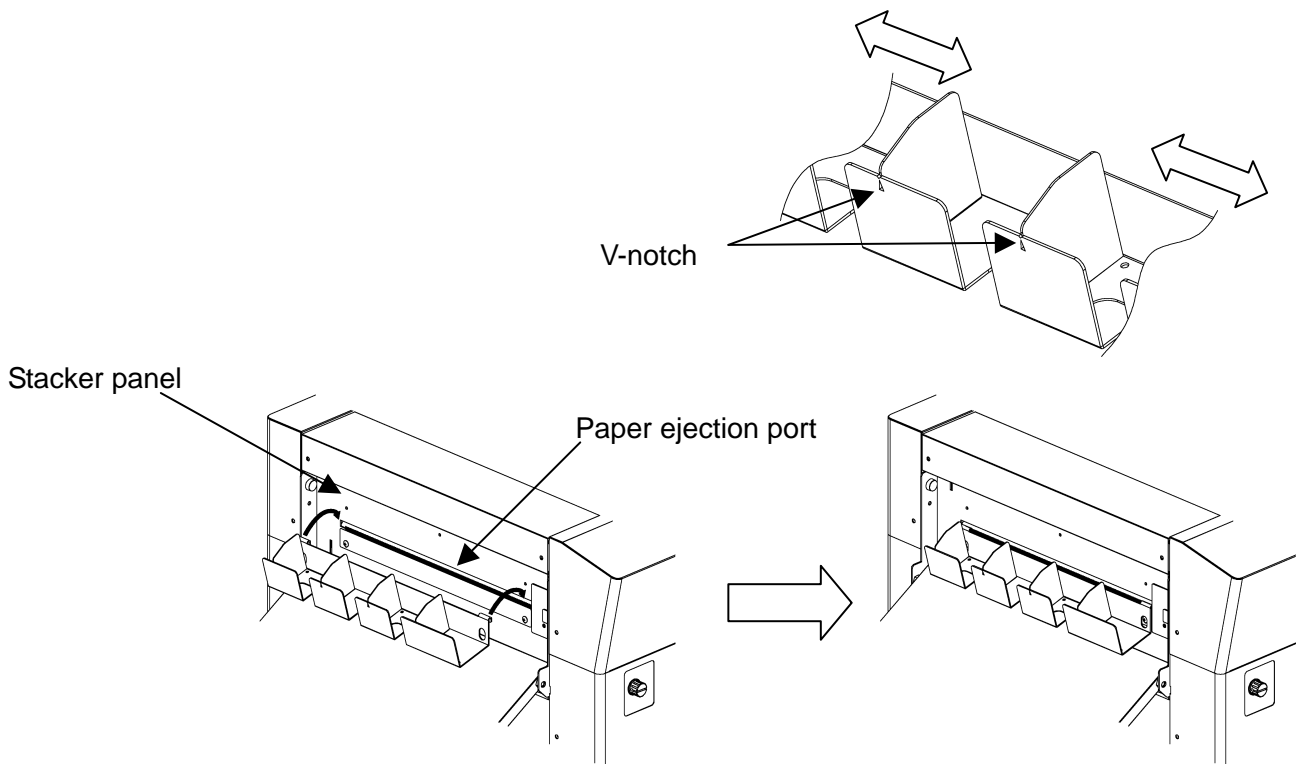

- ① Hang the business card stacker on Paper ejection port of Stacker panel.
- ② Find the V- notch to see where to put the business card stacker.

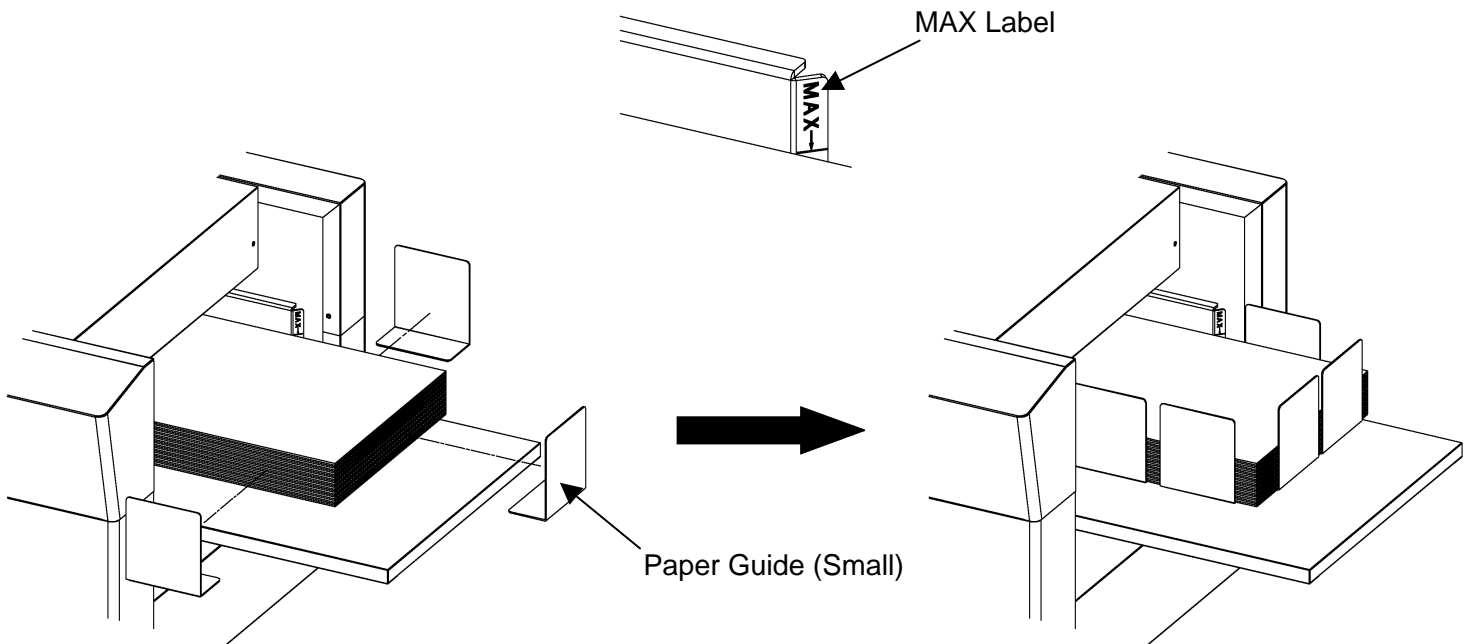

(5) Paper setting

- ① Press **SET** to lower the feed table.
- ② Separate the sheets of paper well and place them on the feed table.
- ③ Fix the paper with the small paper guides.
- ④ Make sure that the paper stack does not exceed the MAX label.



 Caution	
	Ensure that the paper stack does not exceed the MAX label, as it may cause a mechanical failure.
	Separate the sheets of paper well, as it may cause a paper jam.

(6) Paper slant adjustment

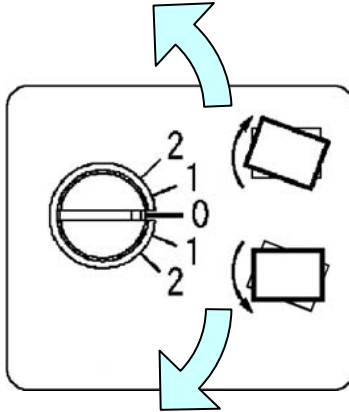

- ① When the printing is tilted, turn the dial as shown in the drawing below to make it straight.
- ② Turning the dial counter-clockwise will tilt the paper to the right, whereas turning it clockwise will tilt the paper to the left.

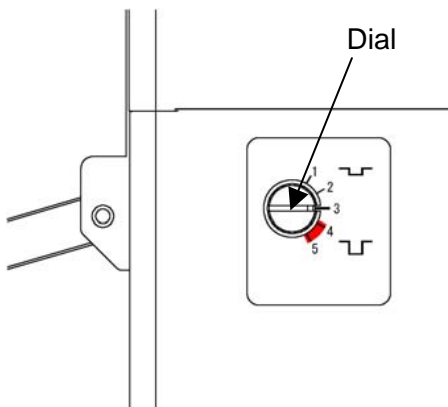

(7) Crease depth adjustment

- ① The sign shown in the drawing below will be displayed when using the creaser.
- ② Turn the dial shown in the drawing below to adjust the crease depth.
- ③ The depth will become the most shallow by choosing Level 1 and the deepest by choosing Level 5.
- ④ When selecting Levels 4 and 5, be careful of the paper thickness. Placing the crease too deep may cause a paper jam or a mechanical failure when the paper is thick.



 Caution	
	Avoid the combined use of the creaser and the perforator, as it may cause a paper jam or a machine failure.
	When selecting Levels 4 and 5, be careful of the paper thickness. Placing the paper too deep may cause a paper jam or a machine failure when the paper is thick.

(8) How to attach the perforator



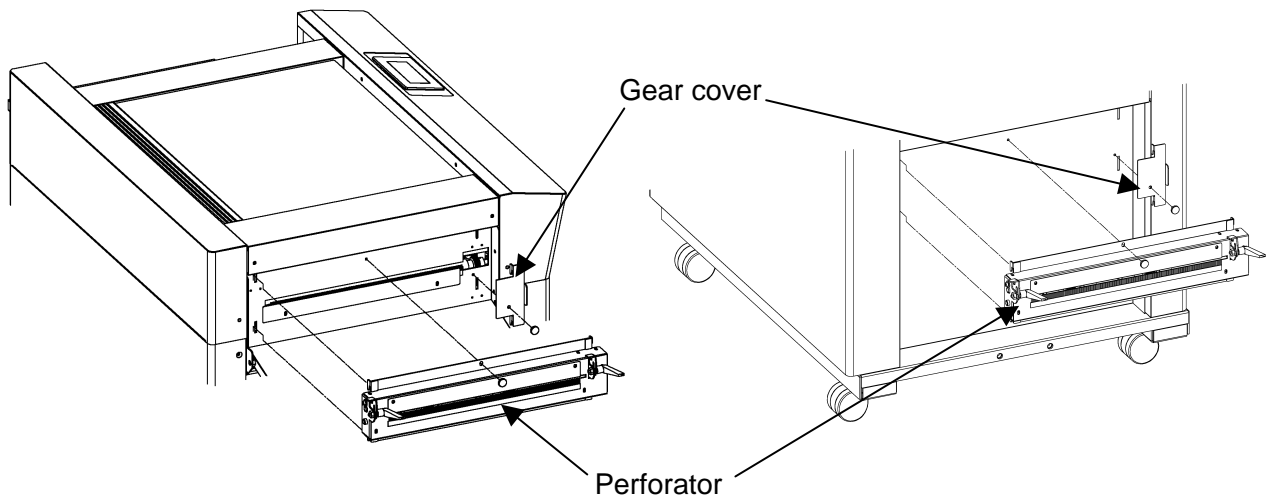

- ① Power it off.
- ② The perforator is stowed below the feed table.
- ③ Detach the gear cover located at the paper exit and attach the perforator.
- ④ The gear cover can be attached where the perforator was initially placed.
- ⑤ The target paper weight for the perforator is 65 lbs (Cover stock) [176 g/m²] or less.
- ⑥ The combined use of the perforator and the creaser on the same paper may cause a paper jam or a mechanical failure.



Caution : Be sure to install Gear cover or Perforator unit !

For safety reason, machine doesn't work with cover open, or if these parts are not in place.





 <h2 style="margin: 0;">Caution</h2>	
	Power it off. Otherwise, Injury could occur.
	The maximum paper weight for use is 65 lbs (Cover stock) [176 g/m ²] for the perforator. Using a heavier paper may cause a paper jam or a mechanical failure.
	Combined use of the perforator and creaser may cause a paper jam or a mechanical failure
	Attach the gear cover when the perforator is not in use, as it may cause injury.

(9) How to adjust the perforation location

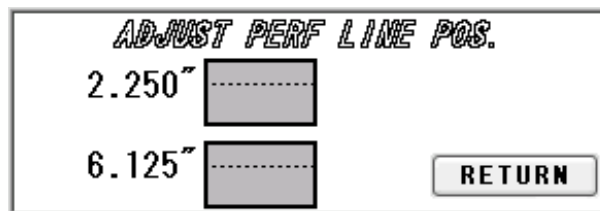
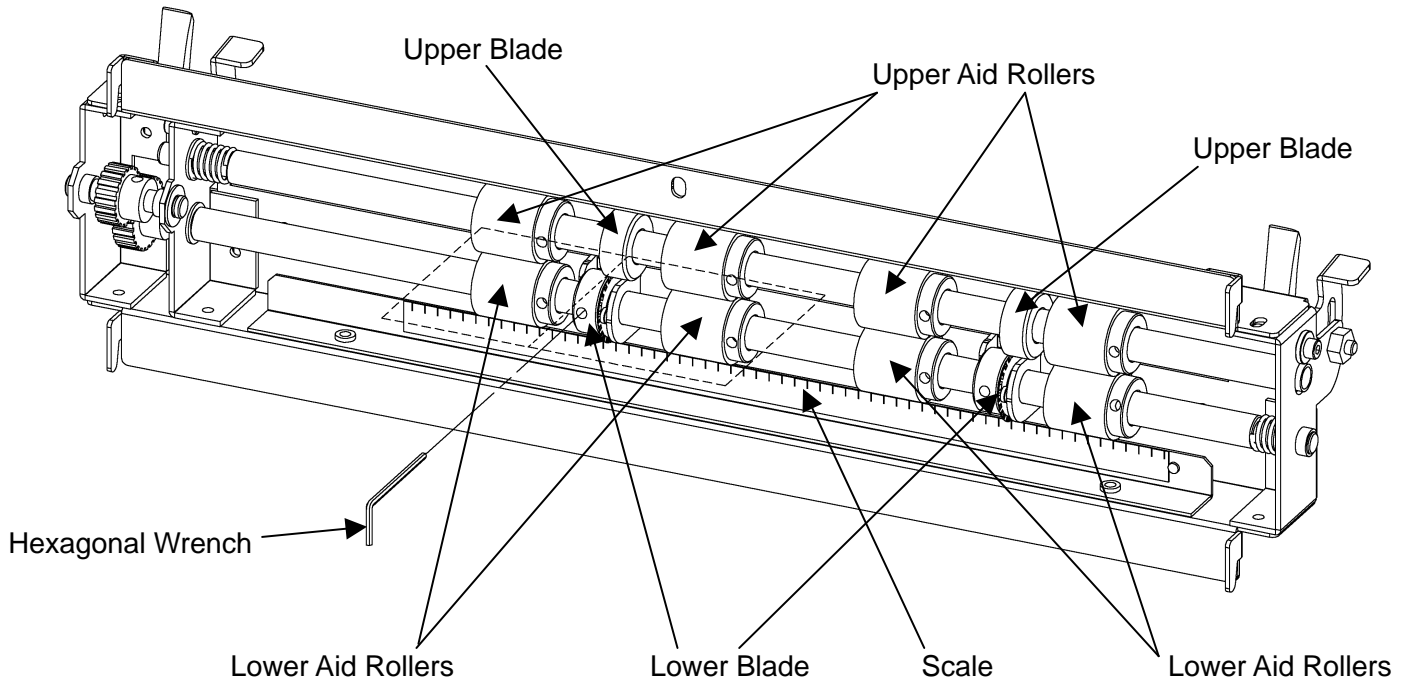
- ① When using the perforator, the screen will display where to fix the perforator, as shown below.
- ② Set the lower blade to the right end of your desired scale and fix it.
- ③ Set the upper blade lightly against the lower blade and fix it.
- ④ Adjust the rest of the aid rollers according to the paper size so that the paper feeding will go smoothly.



 <h2 style="margin: 0;">Caution</h2>	
	<p>Avoid the combined use of the creaser and the perforator, as it may cause a paper jam or a mechanical failure.</p>
	<p>Avoid contacting the cutting edge of the perforating blade. Otherwise, injury could occur.</p>

(10)How to adjust the depth of perforation

- ① Change in the paper thickness, recommend you adjust the depth of Perforation.
- ② Loosen both lock levers, move adjustment levers;
Up=Shallow
Down=Deep
- ③ Lock position by tightening lock lever.

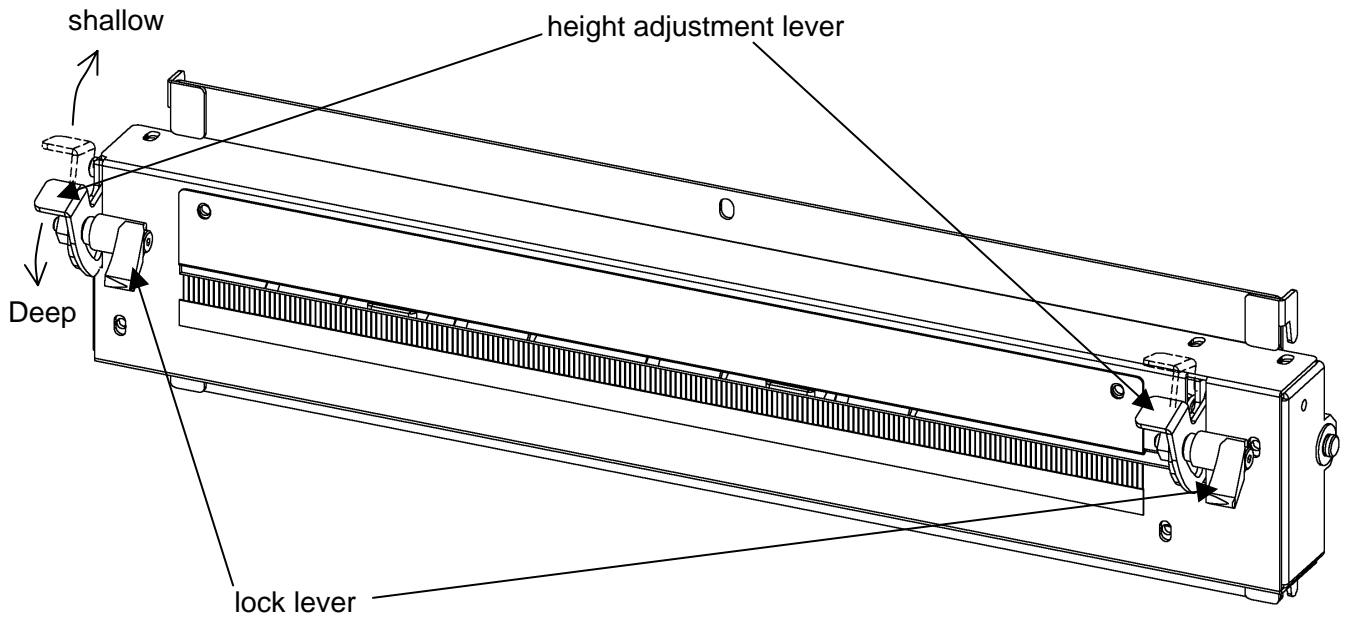

	Caution
	Avoid contacting the cutting edge of the perforating blade. Otherwise, injury could occur.

3. Operational method

(1) Basic operation

- ① Turning the power on.
- ② Slitter initial location movement (When turning the power on initially and after adjusting the head location)
- ③ Format selection/free entry, user program retrieval, etc.
- ④ Slitter and table setting
- ⑤ Creaser adjustment (when using the creaser)
- ⑥ Perforator adjustment (when using the perforator)
- ⑦ Paper setting
- ⑧ Sample cutting
- ⑨ Input value correction and size correction
- ⑩ Start of operation

(2) Slitter initial location movement (When initially turning the power on and after adjusting the head location)

- ① Turn the power on.
- ② Press INITIAL POSITION from the operation screen.
- ③ The slitter will move to the initial position.
- ④ The INITIAL POSITION sign will change to SET upon completion.

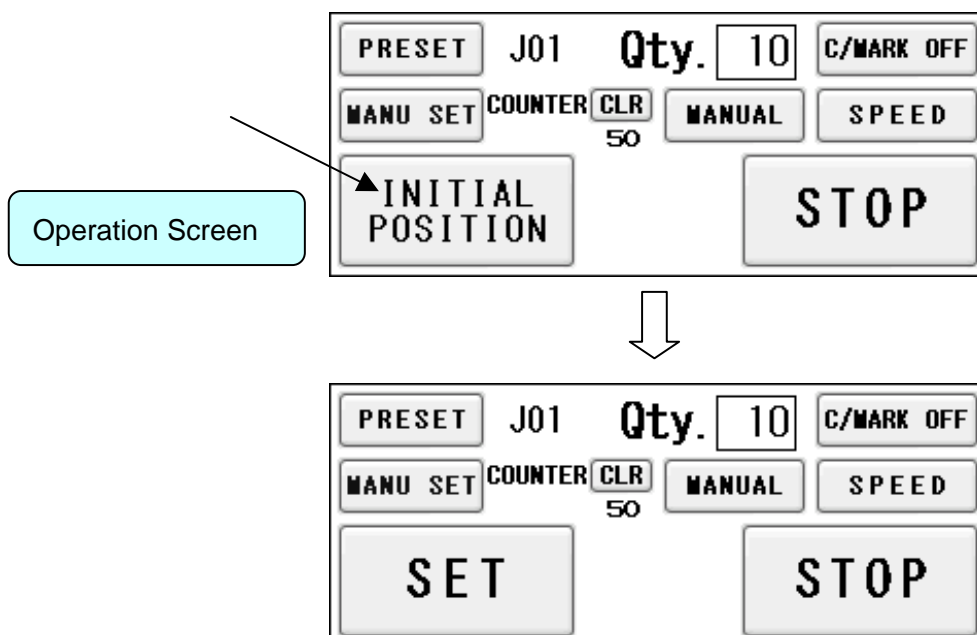

(3) Format selection

① Press PRESET.

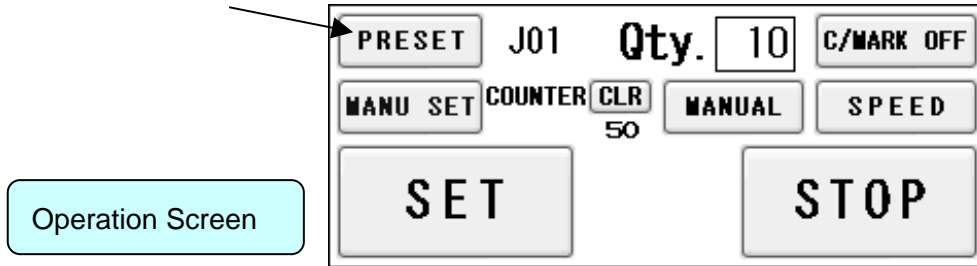

② Select the paper type to be used.

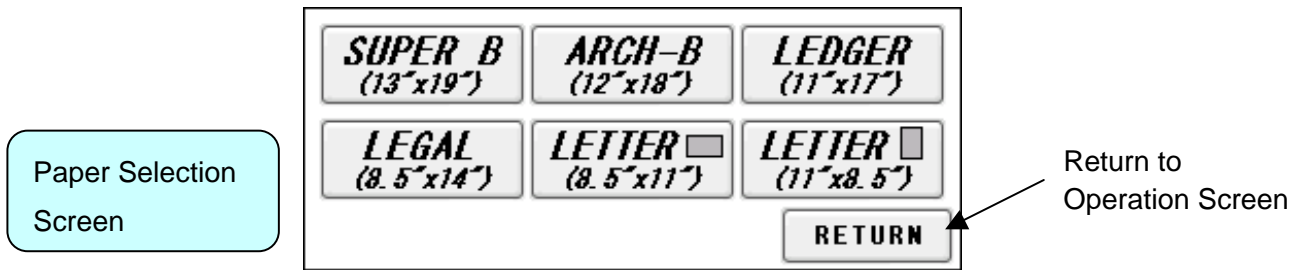

③ Select the cutting pattern.

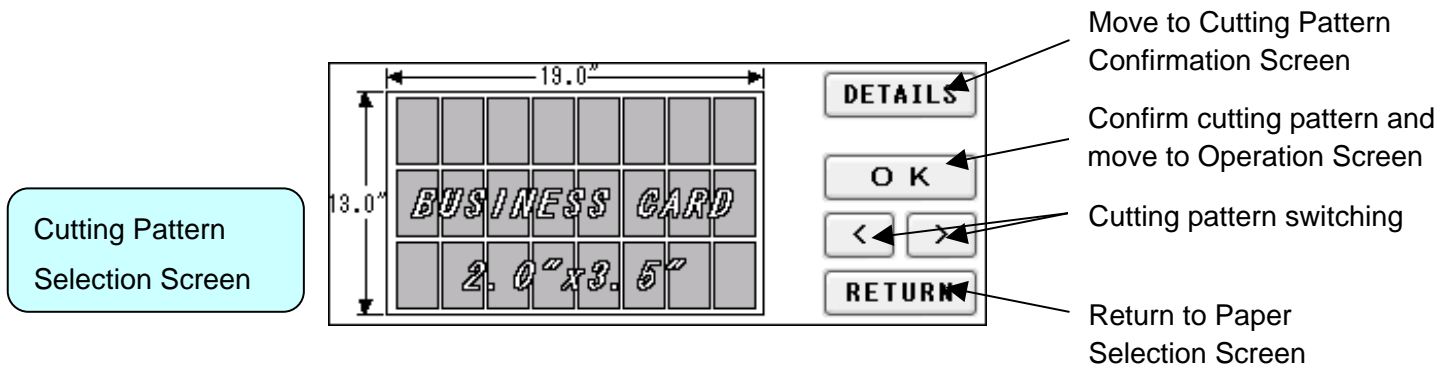

④ Cutting pattern content confirmation and partial correction

Press A through N to make corrections. O,P and M are automatic calculations. It is possible to enter in inches up to the 3rd decimal place.

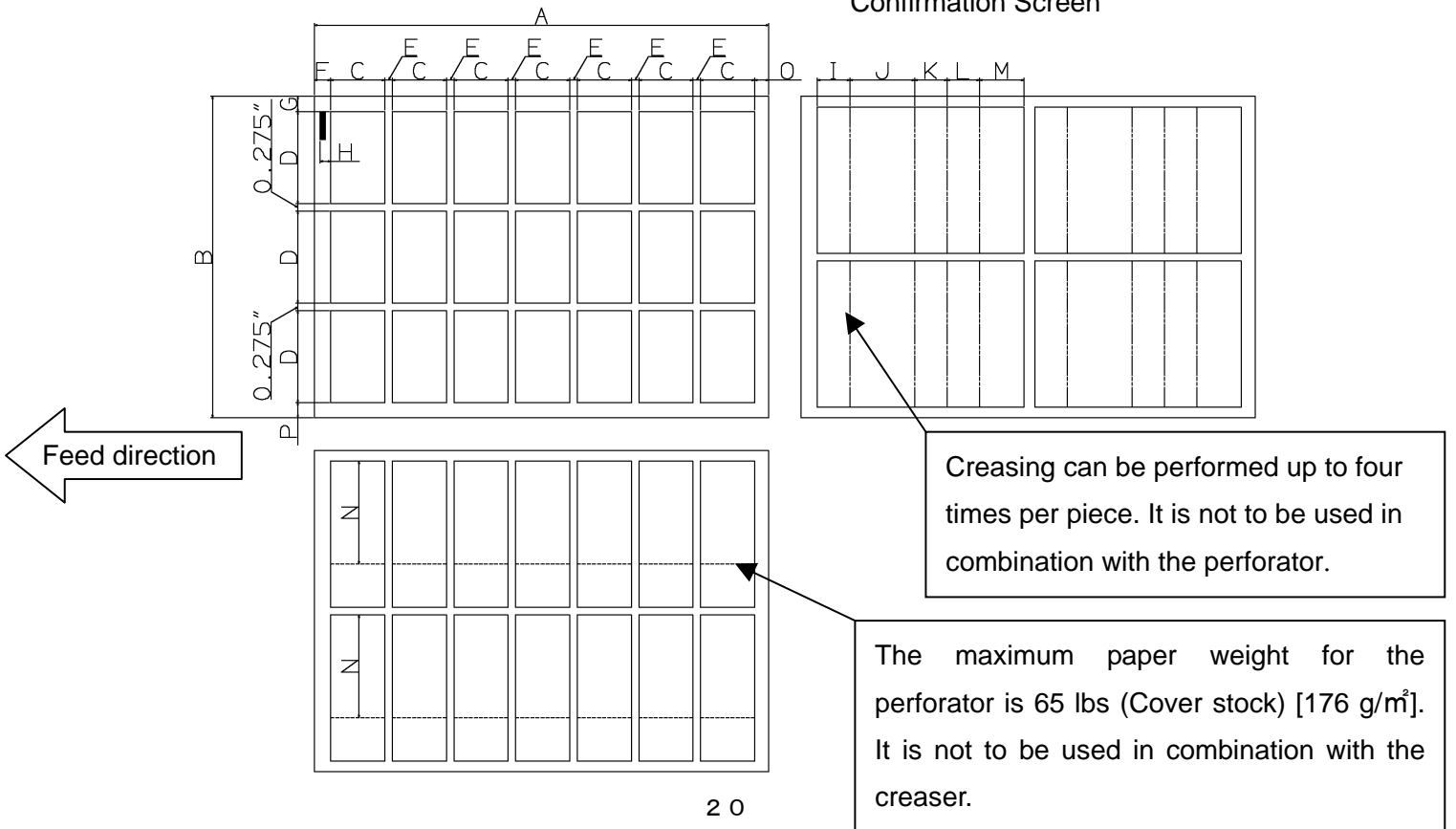
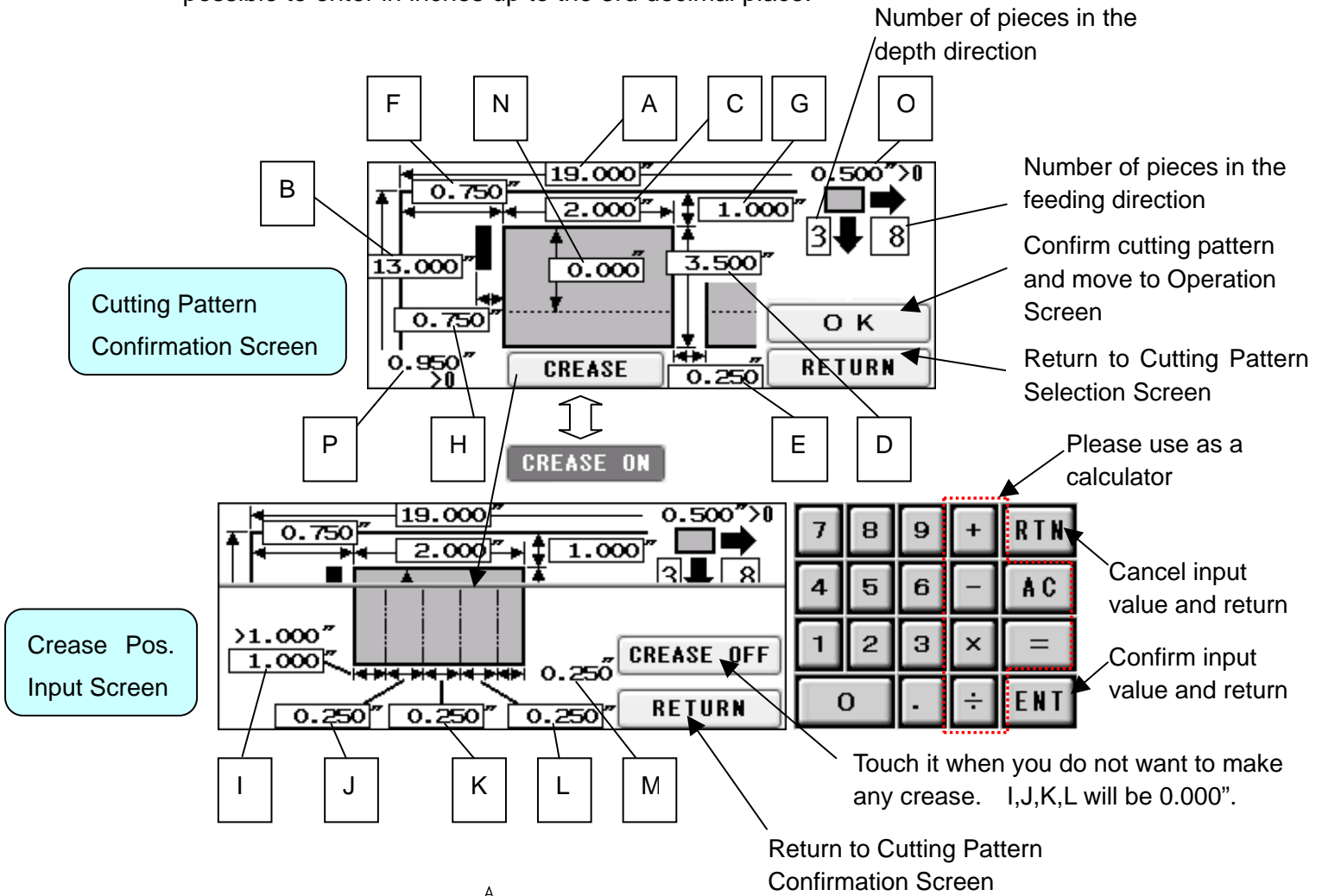

(4) Free entry

① Press MANU SET.

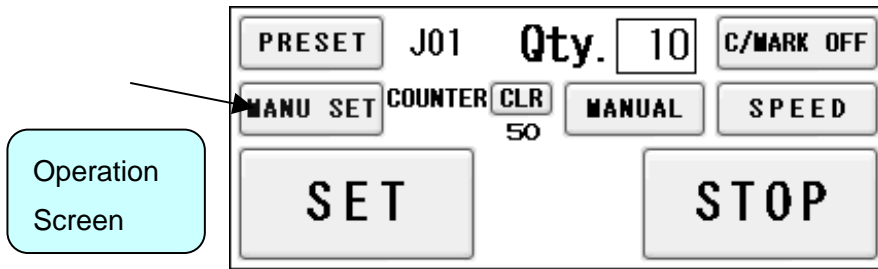

② The operation is almost the same as (3)-④.

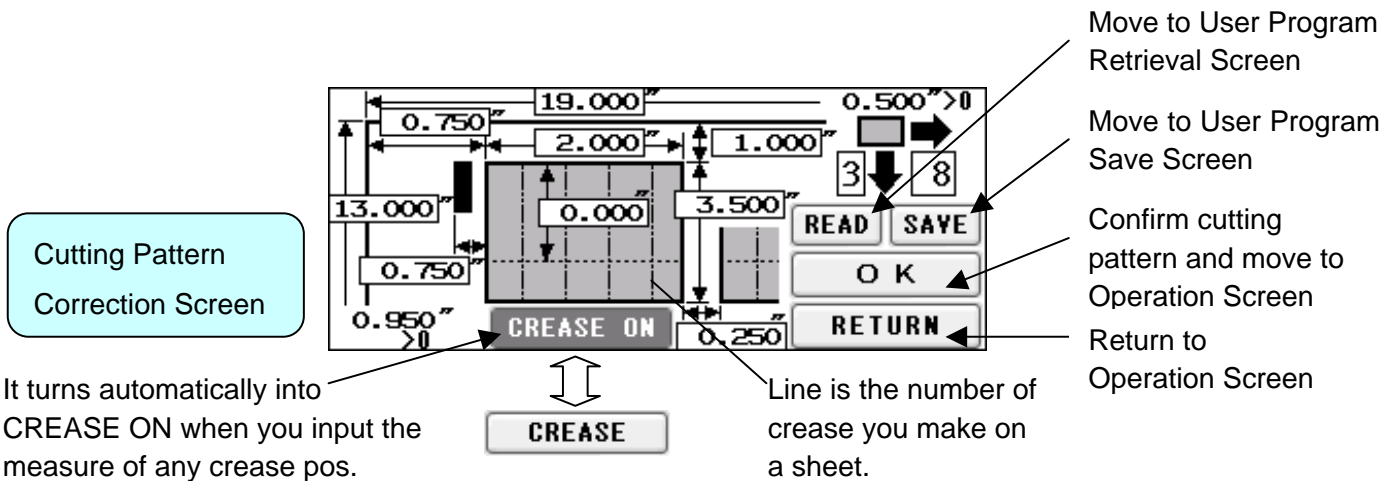

(5) User program retrieval

① 50 user program can be registered.

② Press the button of the name you wish to retrieve.

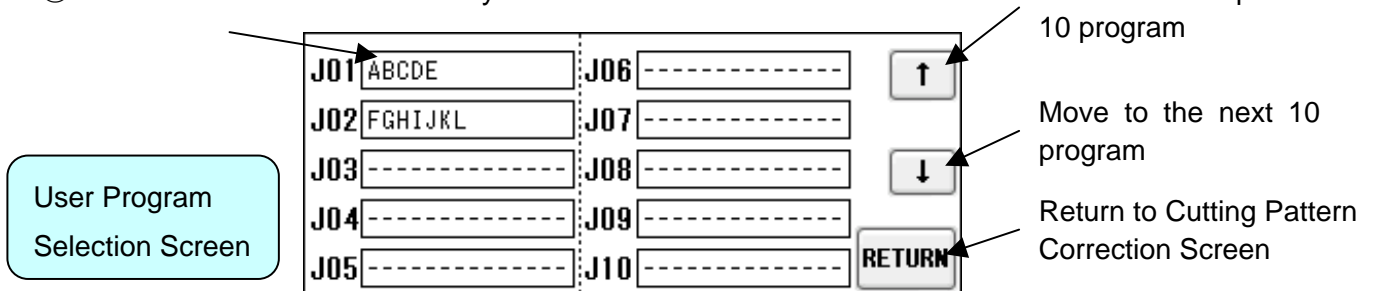

③ Confirm the details of the program for retrieval.

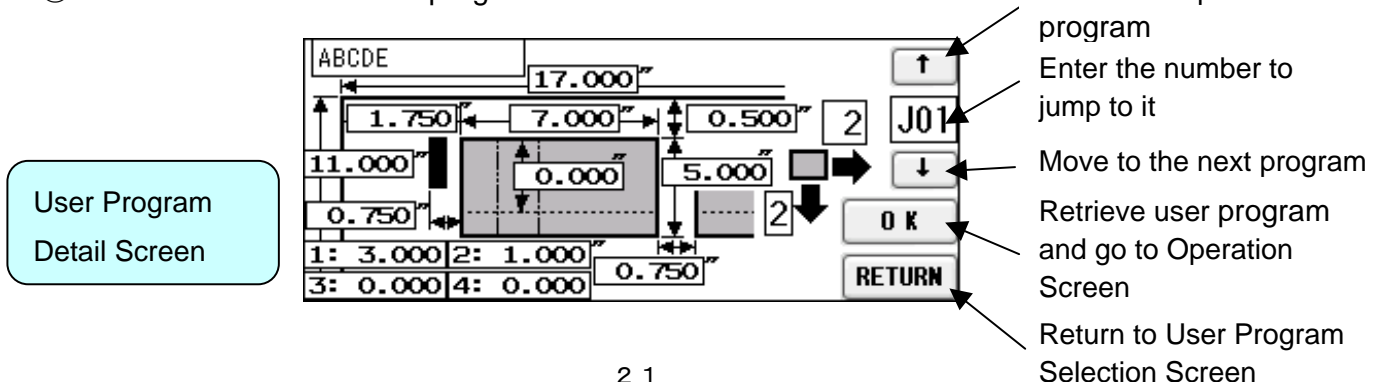

(6) User program registration

- ① 50 user program can be registered.
- ② Press the button in which you wish to make a registration.

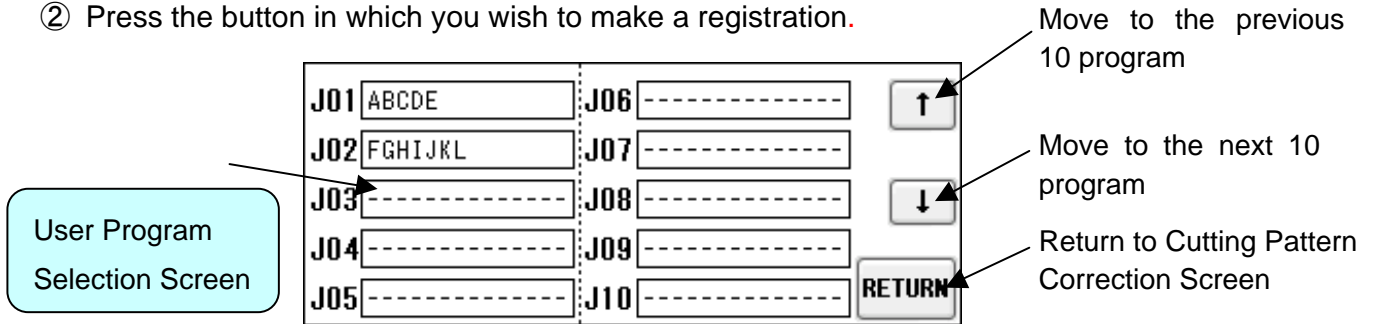

- ③ Confirm the program stored in the selected place.

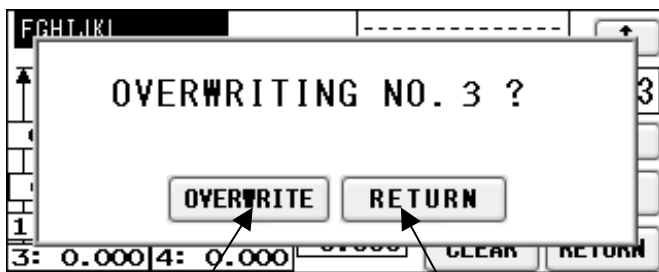
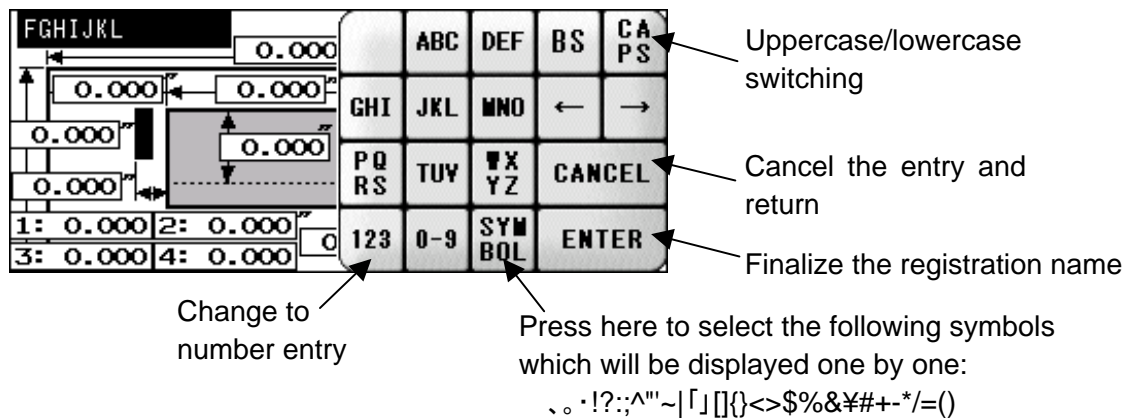
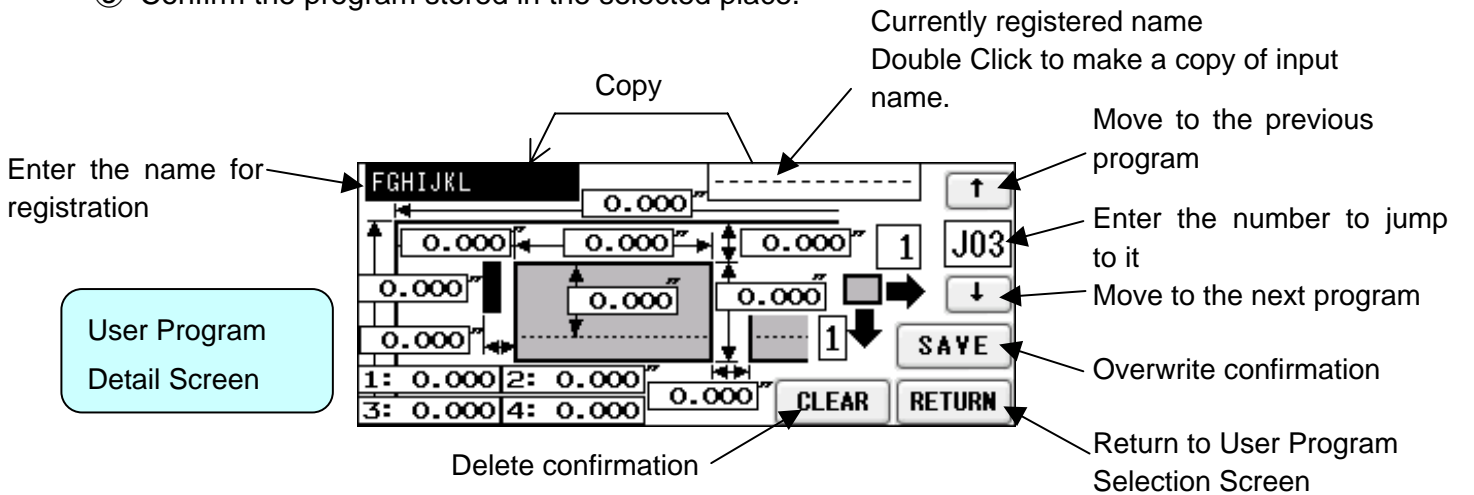

For overwriting and move to Cutting Pattern Correction Screen

Return to User Program Detail Screen

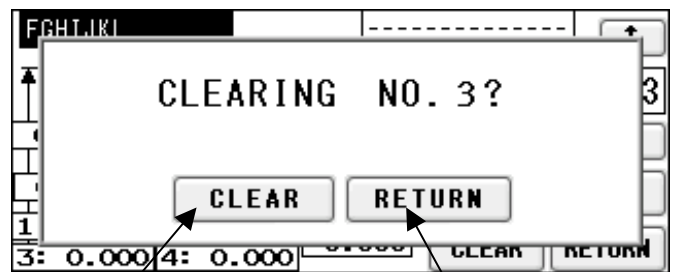

Delete and move to User Program Detail Screen

Return to User Program Detail Screen

(7) Setting of slitter and feed table

- ① By pressing SET, the feed table will be lowered to the bottom dead point and the slitter will move to the operating position.
- ② The display will change from SET to START upon completion.

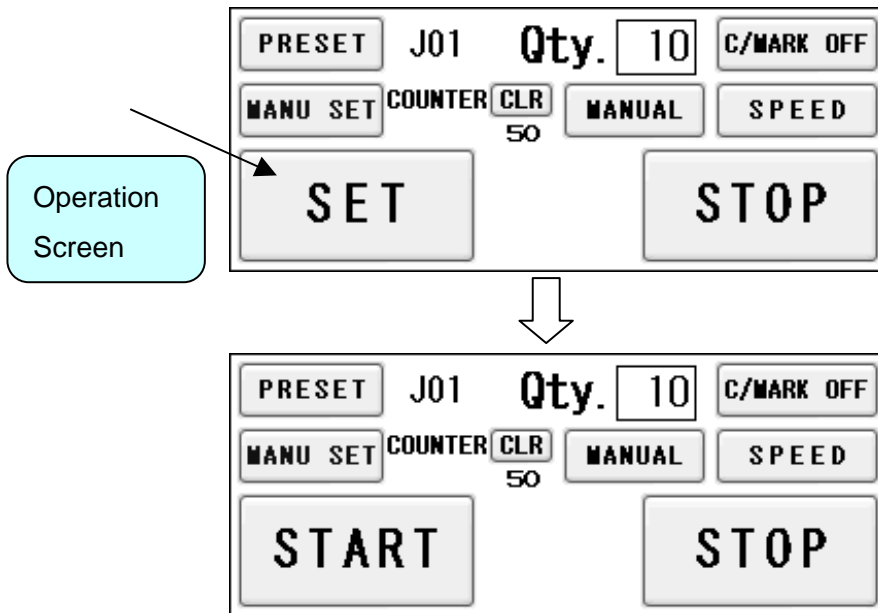

(8) Operation number cancellation

- ① The total number of processed sheets are counted. Press CLR and hold to clear the number. You can change the Total number.

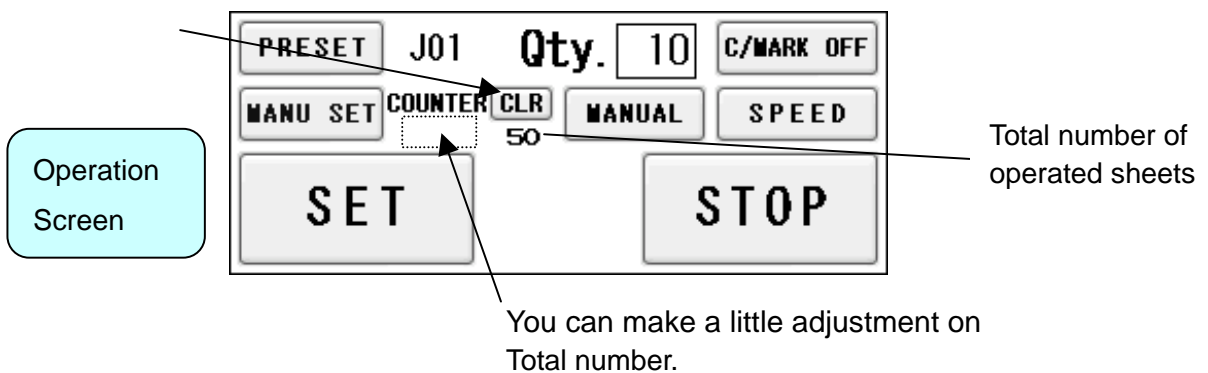

(9) Manual operation

① Press MANUAL.

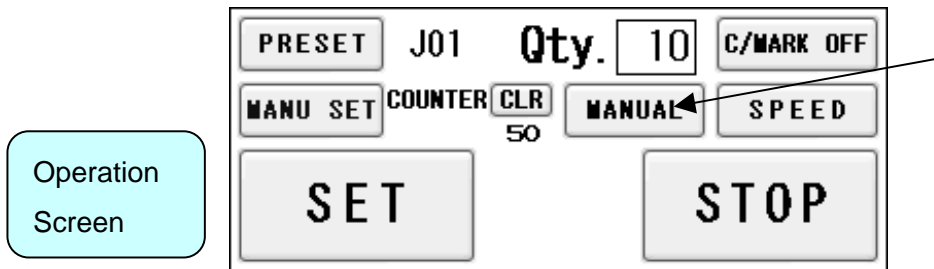

② Use it when operating manually.

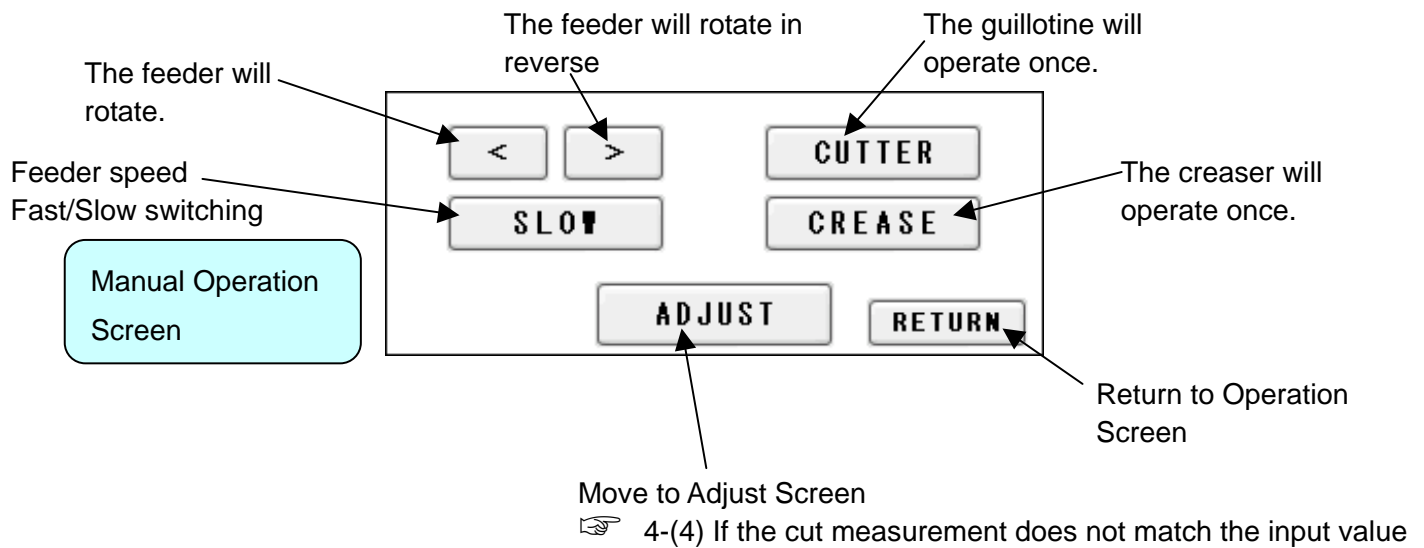

(10) Speed change

- ① Press SPEED from the Operation Screen.

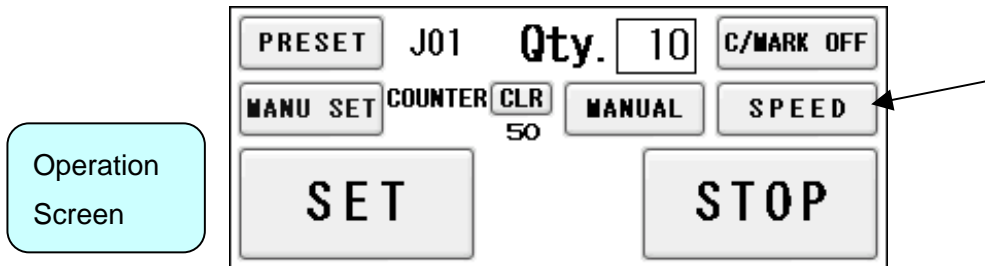

- ② There are eight feeding speed levels. The currently selected speed level is inverted to black. Thick paper should not be fed at higher speeds. Please slow the speed down if sheet stops with noise associated.
- ③ To avoid double feed or skew feed, adjust PAPER FEED WORK TIME and volume of AIR BLOW.

	SHORT	0.5s~5.0s	LONG
PAPER FEED WORK TIME	Double feed: more likely to occur	↔	Double feed: less likely to occur
	Skew feed: less likely to occur		Skew Feed: more likely to occur

	BLOW OFF	SHORT BLOW	LONG BLOW
AIR BLOW	Double feed: more likely to occur	↔	Double feed: less likely to occur
	Skew feed: less likely to occur		Skew feed: more likely to occur

As a recommended default setting, PAPER FEED WORK TIME should be 3.0 seconds and AIR BLOW should be LONG BLOW.

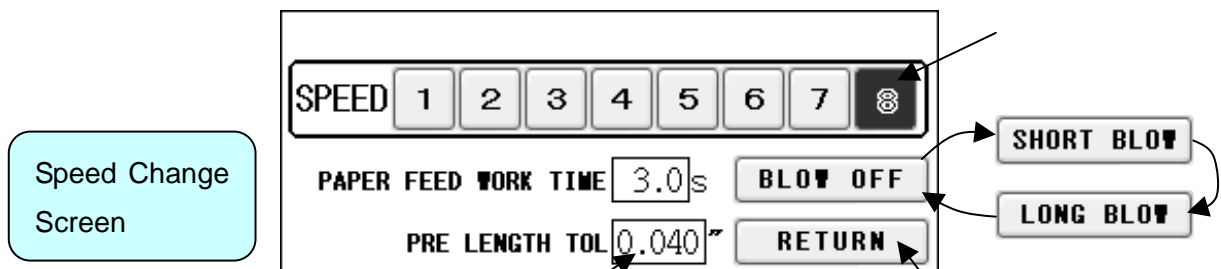

The value is for easy double feed detection. The operation will become an error and stop if a longer sheet of paper than the input value of the first sheet is fed.

Enter 0 when you do not use the function.

Return to Operation Screen

(11) Cut mark on/off selection

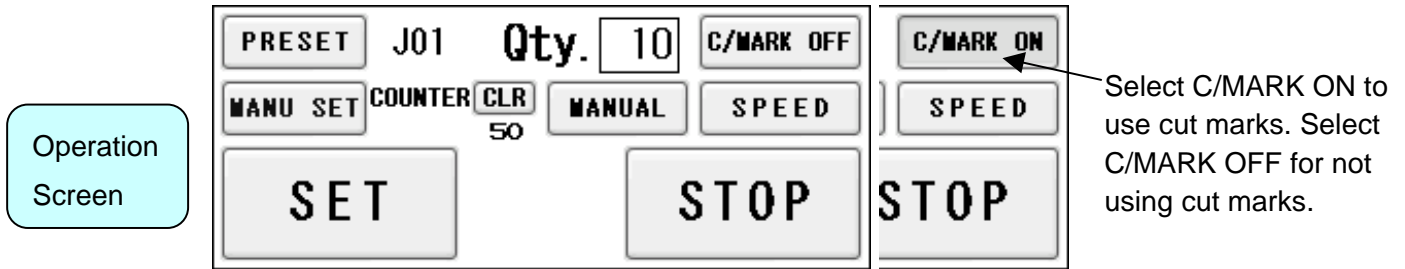

(12) Automatic operation

- ① Set the number of sheets for operation. The machine will automatically stop on reaching the set number. Enter "0" for continuous operations.

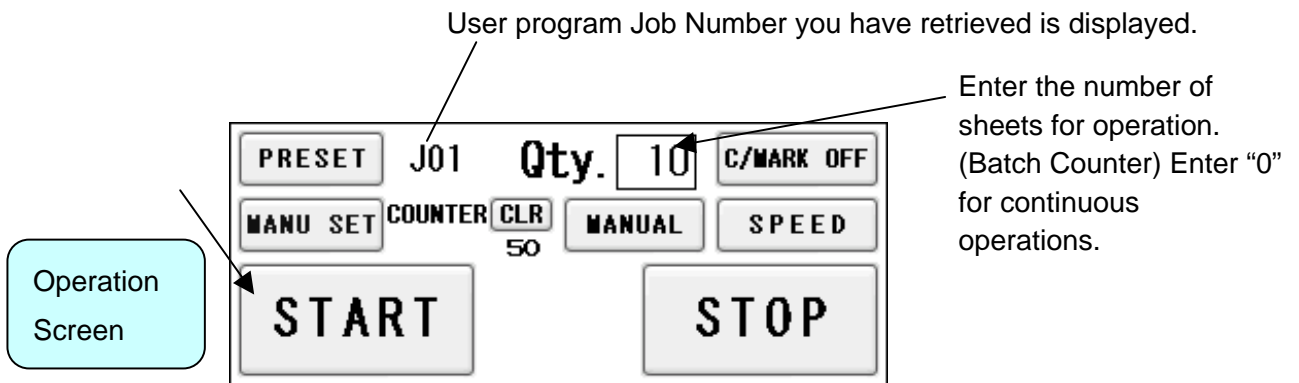

- ② Press START to start an automatic operation. The display will change to RUNNING.
- ③ Press STOP and the machine will make an EMERGENCY stop even if the operation is underway.
- ④ Press END if you wish to stop the machine when the current sheet is completed. The END sign will blink and the machine will automatically stop upon completion of the work.

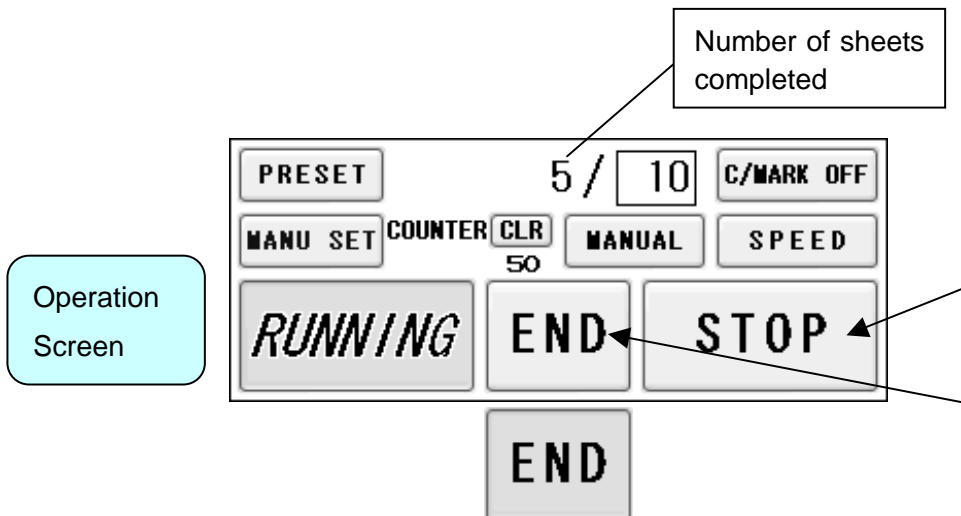

4. Instructions for use



(1) If the machine stops during operation

- ① If the machine stops during operation due to an error such as a paper jam and overloading, paper may still be left in the machine.

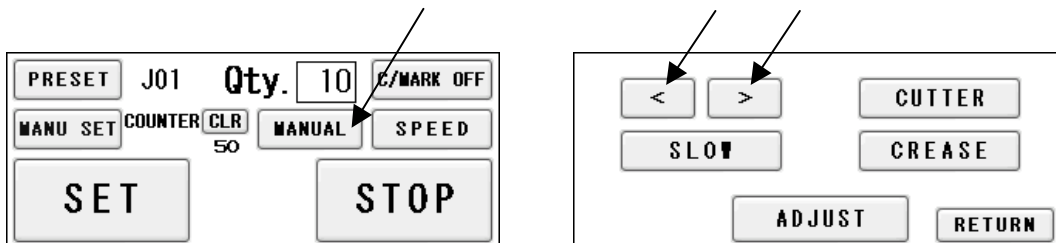

- ② In such a case, the paper must be removed by manual operation, as continuing to operate it may cause a mechanical failure
- ③ Press MANUAL from the Operation Screen, and then press or from the screen, or press or from the error screens as shown above to move the feeder for paper ejection.



 <h2 style="margin: 0;">Caution</h2>	
	<p>Avoid contacting any rotating object. Otherwise, injury could occur.</p>
	<p>Don't bring a hand, face, hair, sleeves of clothes and the like close to the rotating parts of the machine. There is a danger of receiving an injury.</p>

(2) If Paper scrap remains on the machine

- ① If paper scrap remains behind Stacker panel.

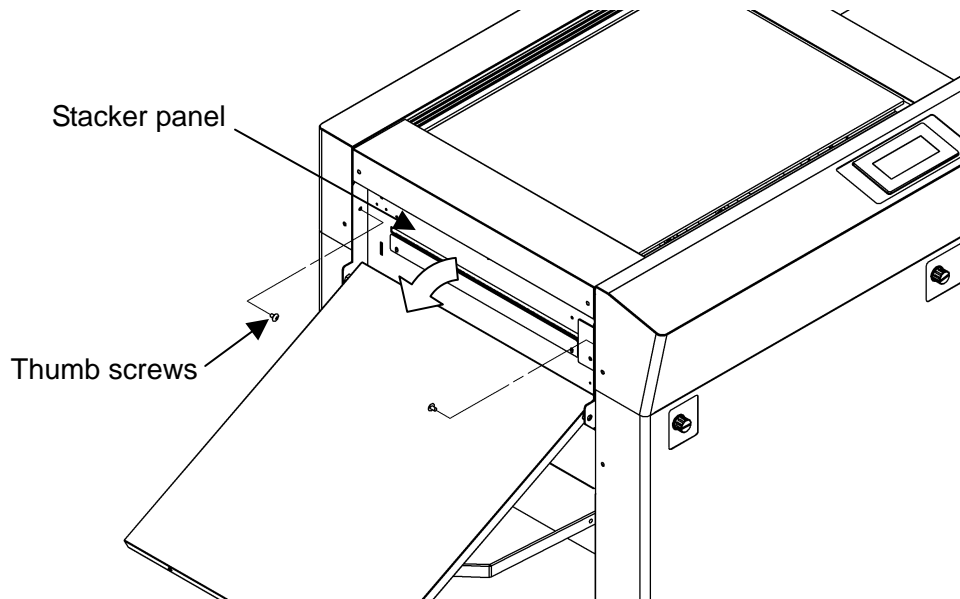

If paper scraps remain in the Crease part of machinery, turn off the machine and open the stacker panel by removing thumb screw on both sides of the Stacker Panel. Pick up paper scraps with Tweezers and take them away.

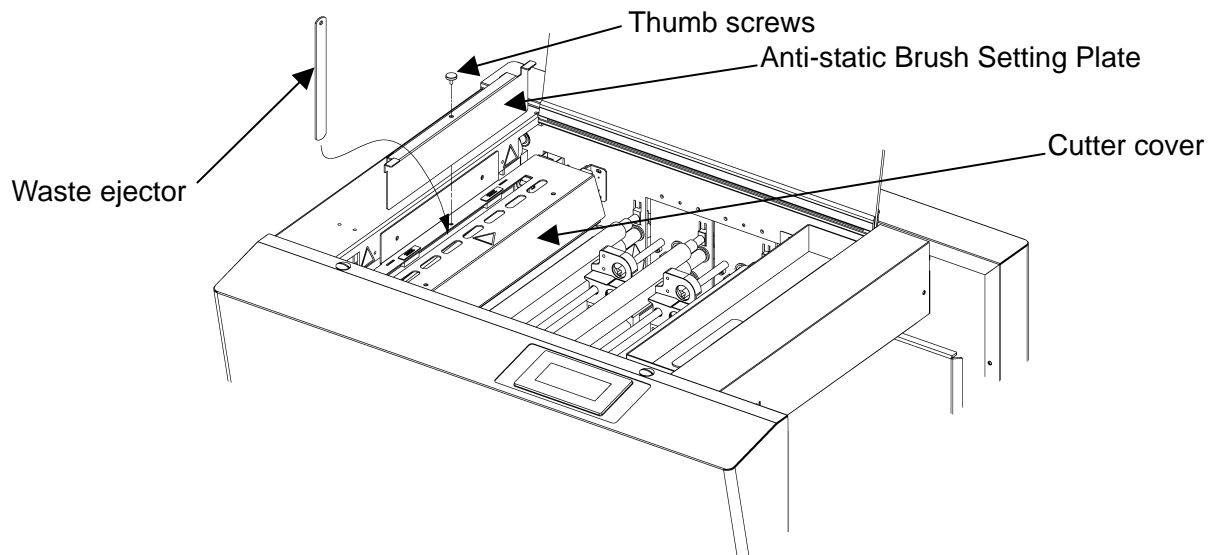

- ② If the paper scrap remains under cutter cover.

If Paper scrap remains under the Cutter cover of the machine, turn off the machine and take off thumb screw to remove the anti-static brush setting plate. After removing plate there will be a space. Push the paper scrap down with Waste ejector, which comes with machine.



 Caution	
	Power it off. Otherwise, Injury could occur.

(3) Details concerning errors

① Paper size error

Correct the paper size to fit in the value range below.

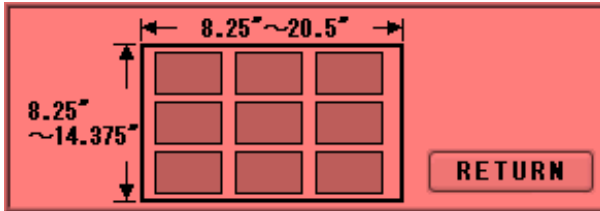

② Final cutting measurement error

Correct the final cutting measurement to exceed the value specified below.

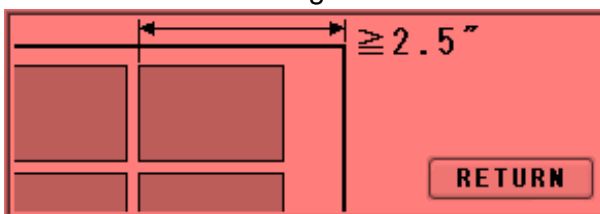

③ Cutting measurement error

Correct the cutting measurement to fit in the value range below. The maximum value is subject to change depending on the entered paper size.

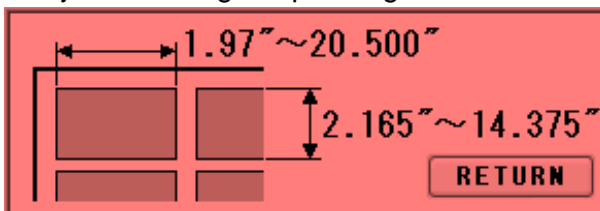

④ Cut piece number error

Correct the number of cut pieces to be in the value range below. The maximum number of pieces is subject to change depending on the operation.

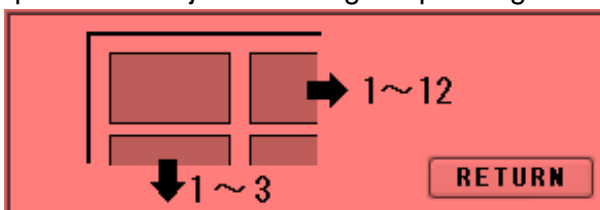

⑤ Bottom margin error

Correct the bottom margin to fit in the value range below.

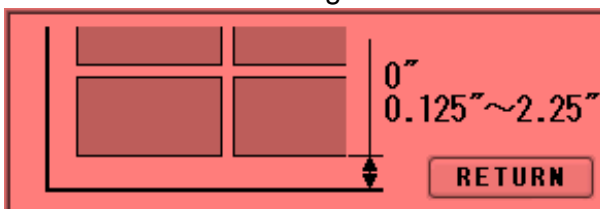

⑥ Top margin error

Correct the top margin to fit in the value range below.

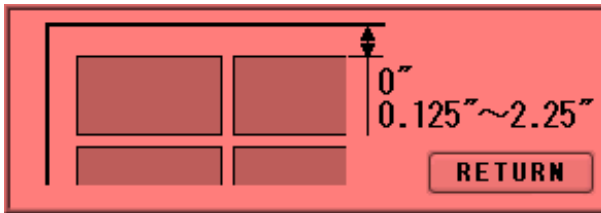

⑦ Back margin error

Correct the back margin to fit in the value specified below.

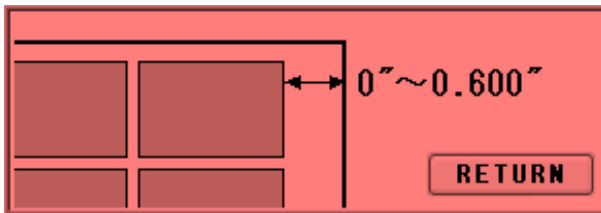

⑧ Perforation location error

Correct the paper size to fit in the value range below.

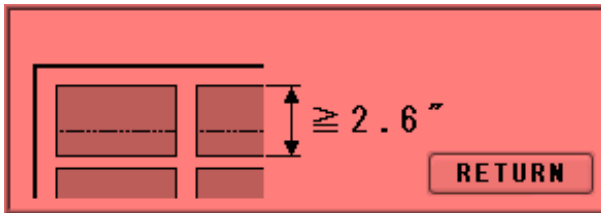

⑨ Crease front margin error

Correct the crease front margin to exceed the value specified below.

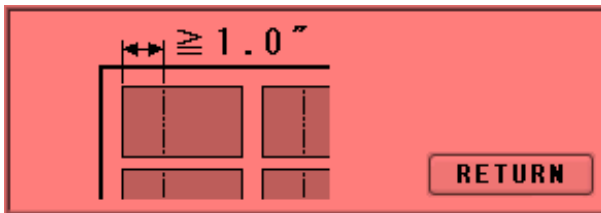

⑩ Crease back margin error

Correct the crease back margin to exceed the value specified below.

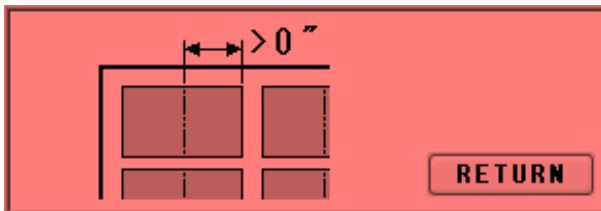

⑪ Perforation location warning

Correct the perforation location to fit in the value range below. The maximum value is subject to change depending on the entered paper size.

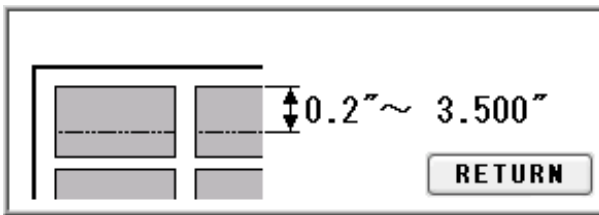

⑫ Leading edge margin and cut mark margin warning

Correct the measurement so that the leading margin becomes larger than the cut mark margin.

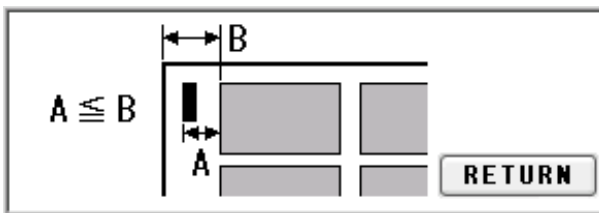

⑬ Cover open error

Safety cover or Stacker panel might be open, Gear cover or Perforator might not be attached correctly.

Make sure to close the Safety cover and Stacker Panel is closed and Gear cover or Perforator is mounted correctly.



⑭ Paper jam error

Paper remains inside the machine. Remove the paper.



⑮ Timeout error 1

Paper was not fed within a set time period. Check the paper feeder.



⑩ Timeout error 2

Paper did not pass through within a set time period. Remove the paper remaining inside the machine.



⑪ Overload error 1

Cutting or creasing did not complete within a set time period. Remove the paper remaining inside the machine.



⑫ Overload error 2

An overloading error occurred at the feed table. Check the feed table.



⑬ Overload error 3

An overloading error occurred at the slitter. Check the blinking slitter.



⑭ Cut mark detection error

Cut mark was unable to be detected. Check the cut mark. Eject the paper inside the machine.



- ②① Paper length variation or double feed detection error
Paper lengths vary. Check the paper.

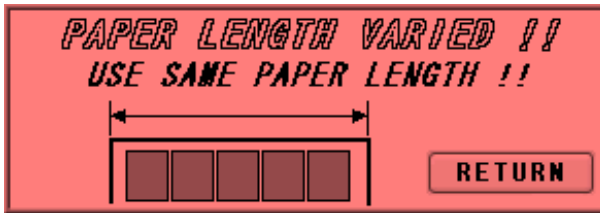

- ②② Slitter units positioning error
Slitter position is out of valid range. Check paper size and input data.



- ②③ Serial communication error
Communication with the touch panel is not possible. Turn off the power, and turn it on again after 5 seconds or longer.

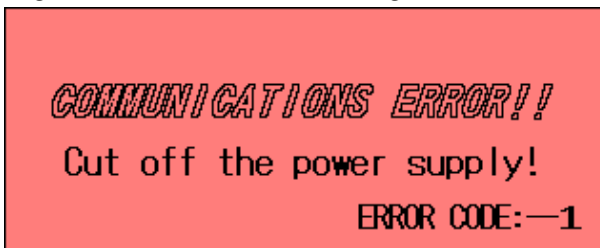

(4) If the cut measurement does not match the input value

- ① If Measurement A is different: When the input value is 0.200" and the actual cut measurement is 0.175", input +0.025"; input -0.040" when the actual cut measurement is 0.240". ※
- ② If Measurements B, C, or D are different: When the input value is 3.500" and the actual cut measurement is 3.560", input -0.060"; input +0.080" when the actual cut measurement is 3.420". ※
- ③ If Measurement E is different: When the input value is 0.600" and the actual cut measurement is 0.620", input -0.020"; input +0.050" when the actual cut measurement is 0.550". (You can input ± 0.400 " at the most)
- ④ If Measurement F (crease location) is different: When the input value is 2.000" and the actual crease measurement is 2.250", input -0.250"; input +0.100" when the actual crease measurement is 1.900". (You can input ± 0.400 " at the most)
- ⑤ If Measurement G is different: When the input value is 0.400" and the actual cut measurement is 0.450", input -0.050"; input +0.100" when the actual cut measurement is 0.300". (You can input ± 0.400 " at the most)
- ⑥ Use H and I for magnificent adjustment. If the printed image is bigger or smaller than the one you designate, you can adjust cutting length to fit the printed measurement with this magnificent adjustment. : When the input value is 4.000" and the actual cut measurement is 4.080", input 0.980 ($4.000 \div 4.080$); input 1.010 ($4.000 \div 3.960$) when the actual cut measurement is 3.960". When this measurement is corrected, Measurements E, F and G will need to be corrected as well. Refer to ③–⑤ above and make corrections. (H must be from 0.500 times to 2.000 times and I must be from 0.800 times to 1.200times)

※ : If you press OK after you input values into A, B, C and D, those values will be added to each total measurements which are circled on the image below. Then, A, B, C and D will be reset to 0.000. You can change the measurement by 0.002". Each adjustment should be within ± 0.080 " at one time. If the gap is more than ± 0.080 ", repeat the process until the desired measurement is reached.

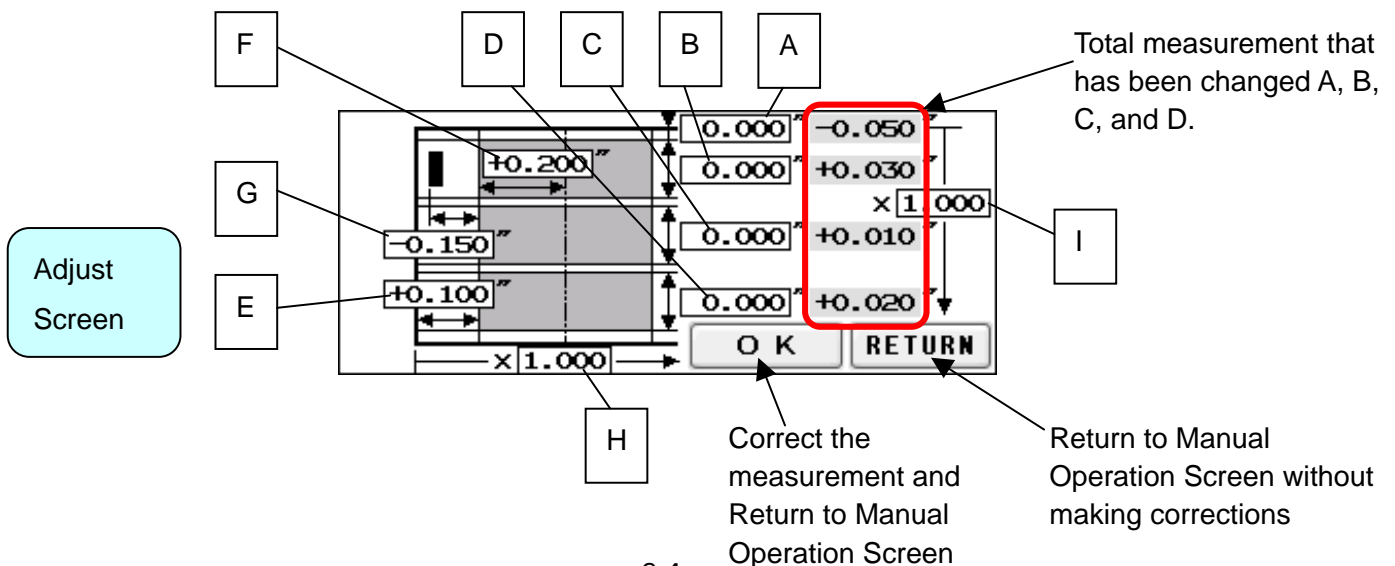

5. Product specifications

Specifications	
Slitter	4 sets (6 slitter blades)
Creaser	1 set (5-level manual crease depth adjustment)
Perforator	2 sets
Number of guillotine or creasing	MAX48times / sheet
Paper size (depth direction)	8.25" (A4 short) ~ 14.375" (B3 short)
Paper size (feed direction)	8.25"(A4 short) ~ 20.500" (B3 long)
Finish size	MIN1.97"W × 2.165"D
Paper weight	32 lbs (Bond) – 130 lbs (Cover stock) [120-350g/m ²]
Maximum paper curl size	±0.125"
Paper type	Offset, Coat, UVcoat, Glossy, Laminate
Paper feeding method	Air Suction
Input tray capacity	MAX2.35"
Speed	MAX 10 sheets per minute (in case of one cut from A4 to A5)
Machine dimensions	34.5" W × 28.1" D × 40.8" H (Occupancy area: 67.7" W × 28.1" D × 59.1" H)
Net weight	397lbs. (180Kg)
Power supply	Single phase 100-240VAC, 50/60Hz, 2.0A-0.8A
Power consumption	200W
Use temperature	23 to 104°F (-5 to 40°C)
Preservation temperature	-13 to 149°F (-25 to 60°C)
Use temperature humidity	45~85%RH
Preservation humidity	25~100%RH
One's tolerance level	100~240V +6%, -10%
Over voltage category	Category III according to IEC60664-1
Pollution degree	Degree 3 according to IEC60664-1

① Paper size

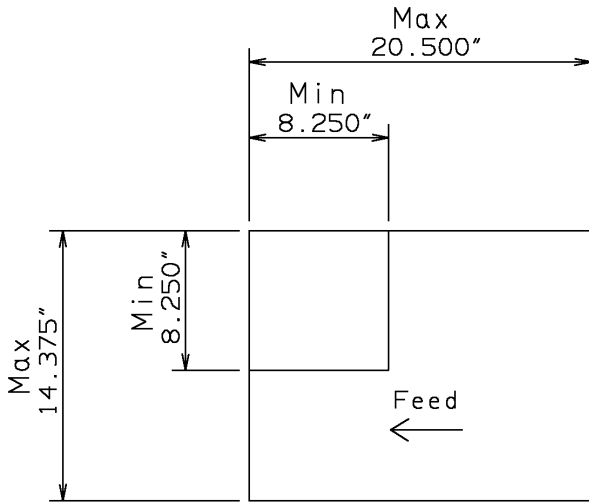

② Finish size

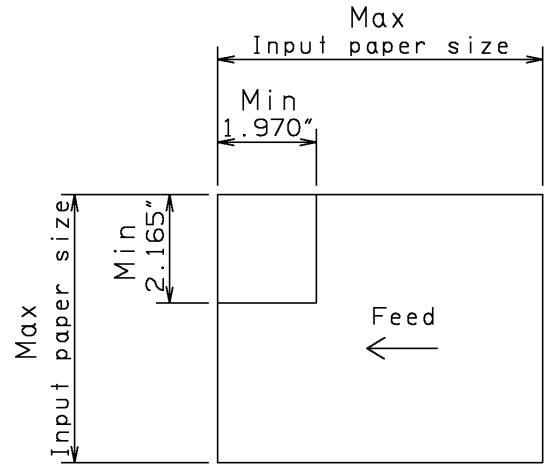

③ Limitations

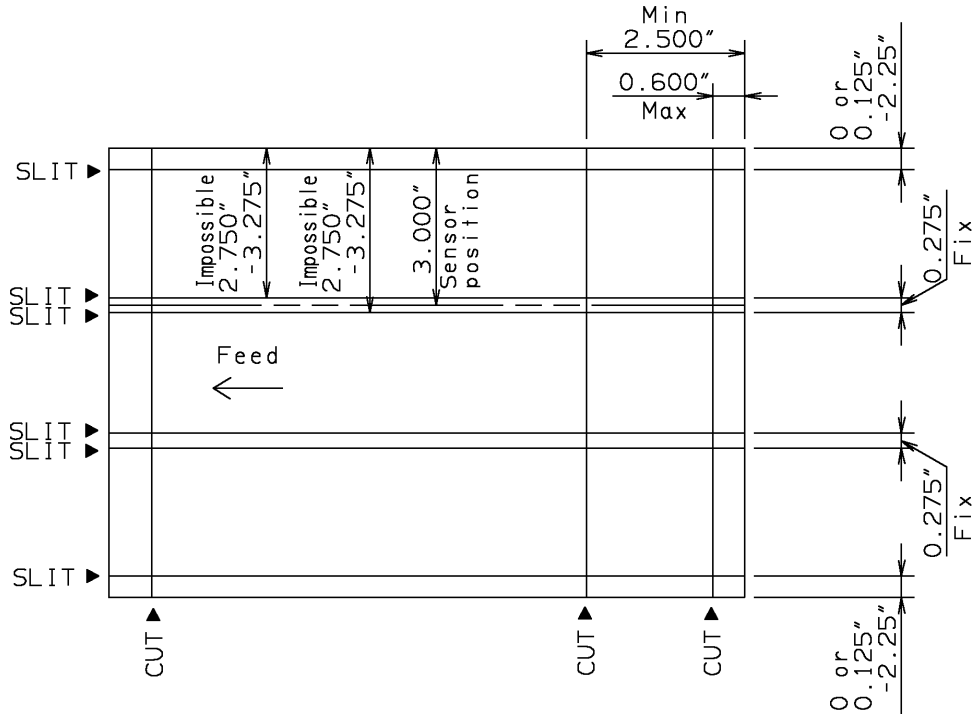

④ Cut mark size and position

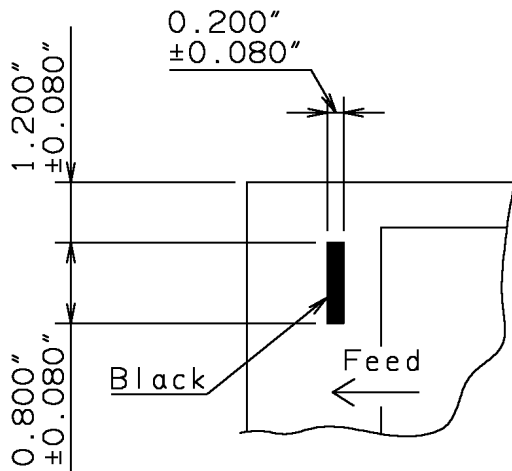

⑤ Crease limitations (Max. four times)

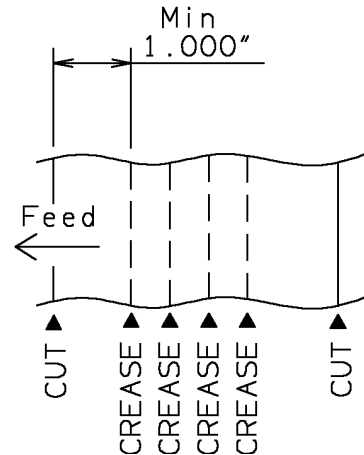

6. Equipment, Electric circuit and parts

No.	Name of item	Qty.	Materials
1	Stacker	1	Steel
2	Feed table	1	Steel
3	Waste chute	1	Steel
4	Perforator unit	1	Steel
5	Power switch	1	
6	Inlet	1	
7	Touch panel	1	
8	Waste box	1	Resin
9	Caster	4	Resin
10	Safety cover	1	Resin

(67.7")

(40.8")

(34.5")

(28.1")

(59.1")

1/2°

33.7"

40.2"

3

9

8

1

2

7

10

6

5

4

6

revision	Approval	Check	Design	Draw	Date	2011	7	5
△								
△								
△								

UCHIDA YOKO CO.,LTD. AeroCut

Scale / . . . /

Electric Circuit (V2.00)

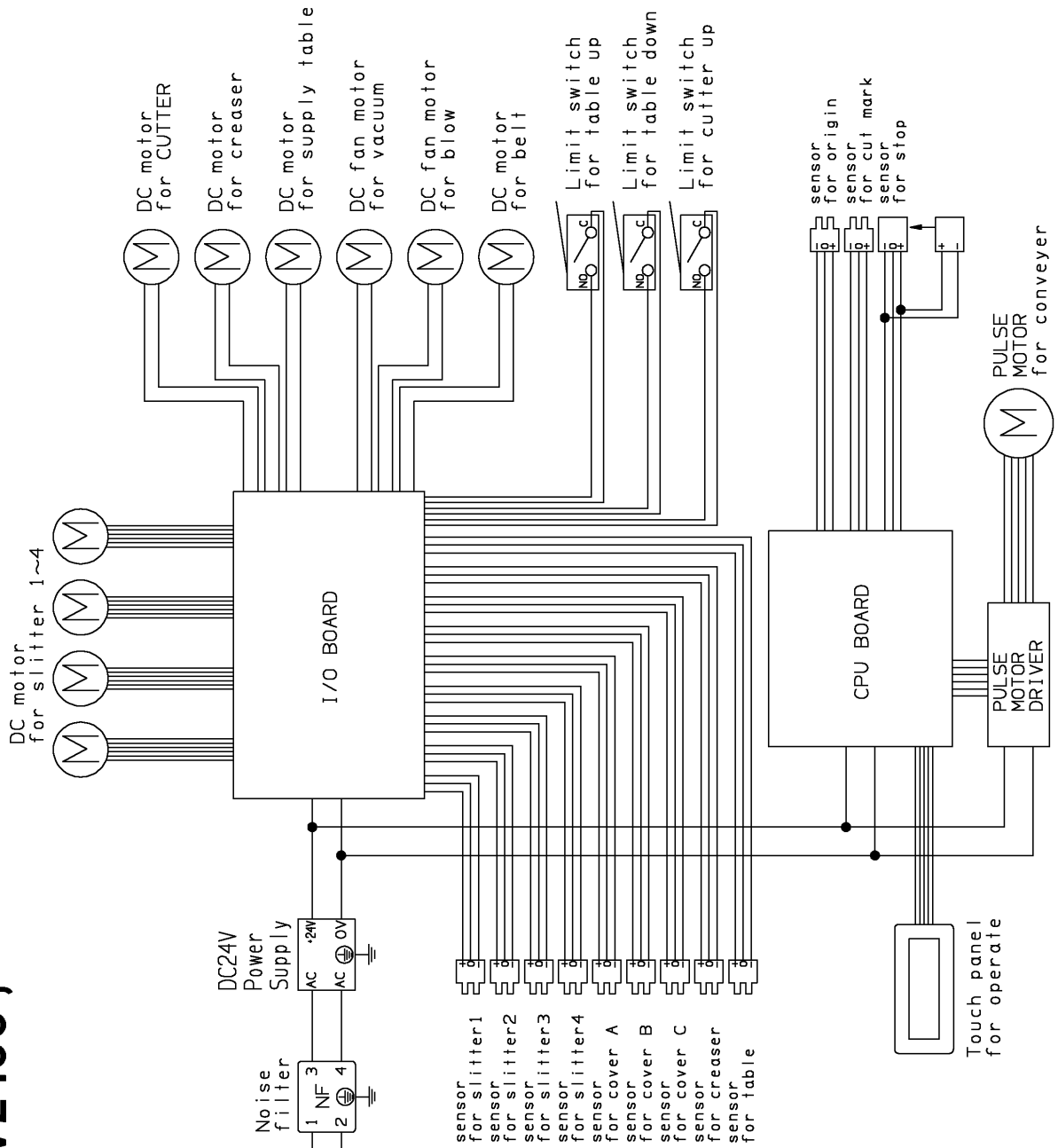

Electric Parts

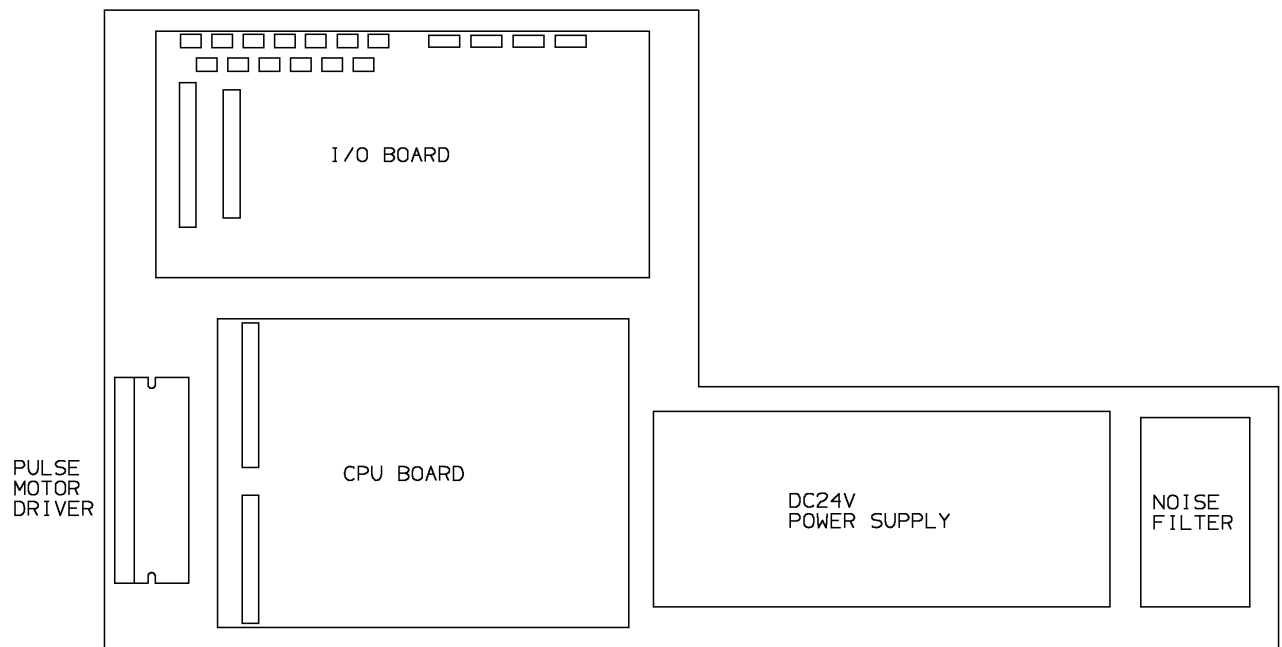

7. Ordering consumables, etc.

When ordering consumables or parts, be sure to specify the machine model.

Keep this "Operation Manual" at an appointed place with care so that it may be available whenever required.

If this "Operation Manual" is stained or lost, make contact with the distributor or our salesman or customer service section to ask for a new operation manual after making sure of its contents.