

Balt Beta Cart Adjustable Sit and Stand Workstation - 27614

Instruction Manual



Provided by

MyBinding.com
When Image Matters.





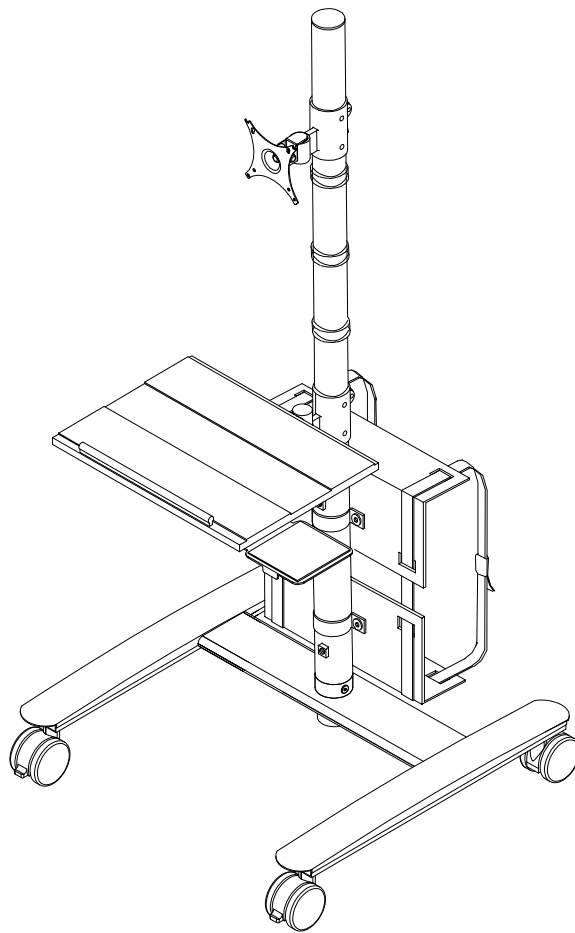





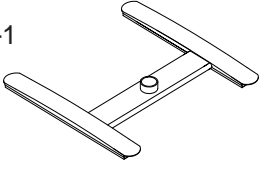
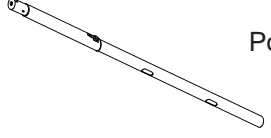

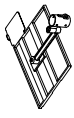



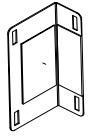

Call Us at 1-800-944-4573

27614 Beta Cart

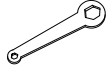

Assembly Instructions

27614 Beta Cart

Part	Drawing	Description	Qty	Part	Drawing	Description	Qty
P-1		Base	1 EA	Hardware List			
P-2		Pole	1 EA	A		3" Locking Caster	2 EA
P-3		Main Platform	1 EA	B		3" Non-locking Caster	2 EA
P-4		Monitor Mount	1 EA	C		Electrical Clip	3 EA
P-5		CPU Mount	2 EA	D		Long Bolt	1 EA
P-6		CPU Mount Clamp	2 EA	E		Allen Wrench	1 EA
				F		Caster Wrench	1 EA
				G		Screw M6*15mm	4 EA
				H		Wrench	2 EA
				I		CPU Strap	2 EA
				J		Screw M6*12mm	4 EA
				K		Book Stop Phillips Screw	3 EA
				L		Book Stop	1 EA
				M		Electrial Strip Screws (Optional)	2 EA

Assembly Diagram

READ THROUGH INSTRUCTIONS FROM BEGINNING TO END BEFORE STARTING TO ASSEMBLE UNIT.

- 1.) Identify and Separate all the Parts and Hardware.
- 2.) Screw in two Locking Casters (A) into the bottom front of the Base (P1) and two Non-Locking Casters (B) as shown in Illustration # 1. Tighten casters with Caster Wrench (F).
- 3.) Insert the Pole (P2) into the Base (P1) and secure to the Base using one long Bolt (D) and four small Screws (G) as shown in illustration #2.

Illustration # 1

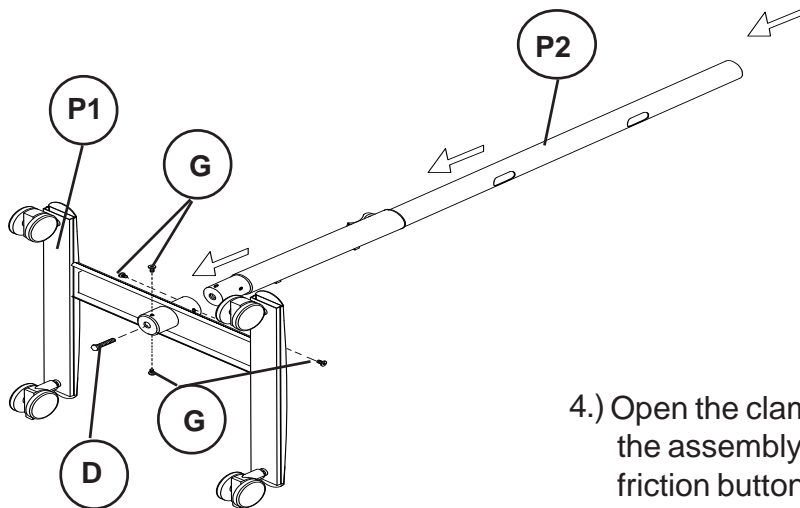
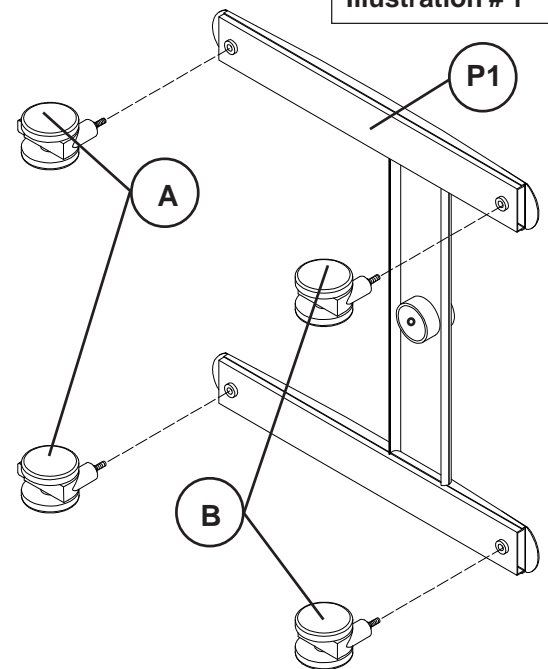

Illustration # 2

- 4.) Open the clamp up on the Main Platform (P3) and slide the assembly down the Pole (P2). Make sure the friction button inside the clamp is retracted. When the Main Platform is in position, lock the clamp lever down to secure it in place as shown in illustration #3. Attach the Book Stop (L) to the Main Platform (P3) using three Book Stop Screws (K) as shown in illustration #3a.

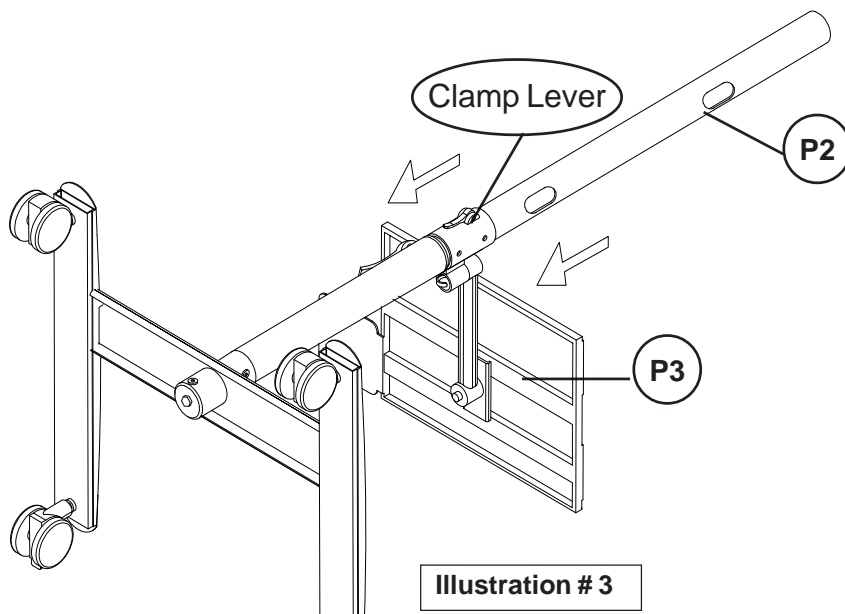

Illustration # 3

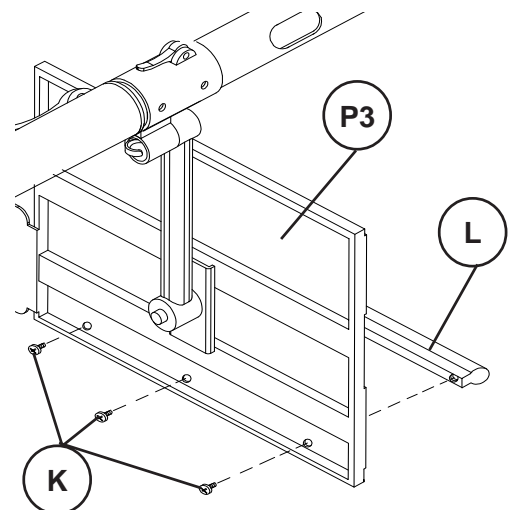
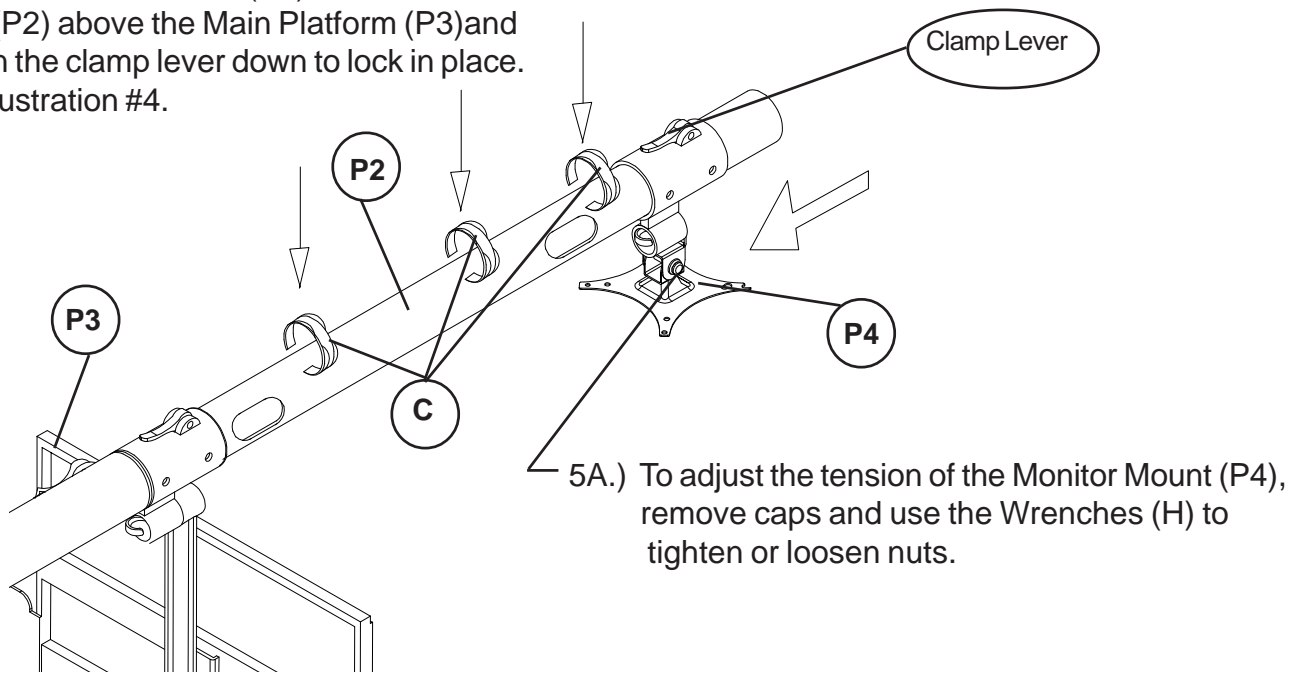

Illustration # 3a

- 5.) Slide the Monitor Mount (P4) down the Pole (P2) above the Main Platform (P3) and tighten the clamp lever down to lock in place. See illustration #4.



- 6.) Snap-On three Cable Ties (C) onto the Pole (P2) . See illustration #4.

- 7.) Attach the two CPU Mounts (P5) to the Pole (P2) using four Screws (J) through two CPU Mount Clamps (P6) as shown in illustration #5. Tighten Screws (J) with Allen Wrench (E).

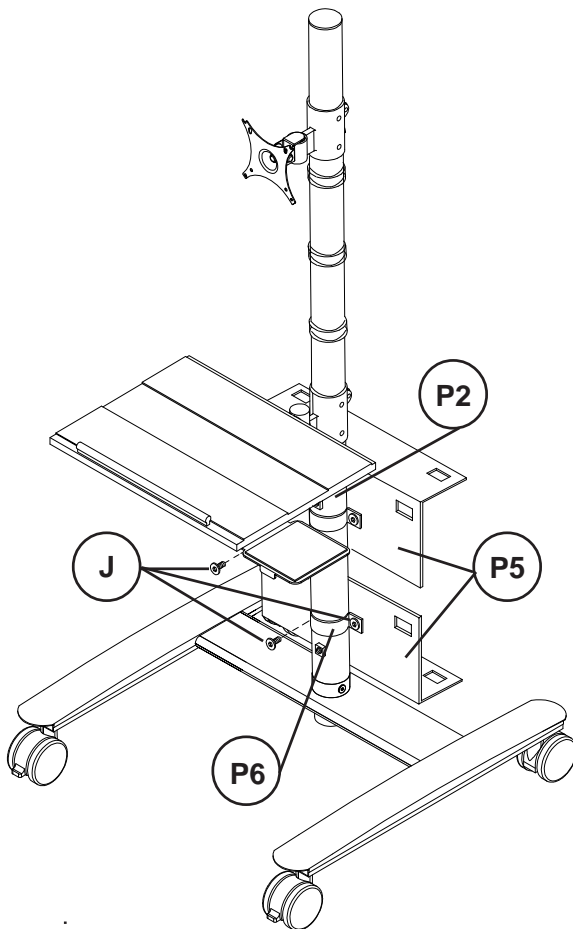

Illustration # 5

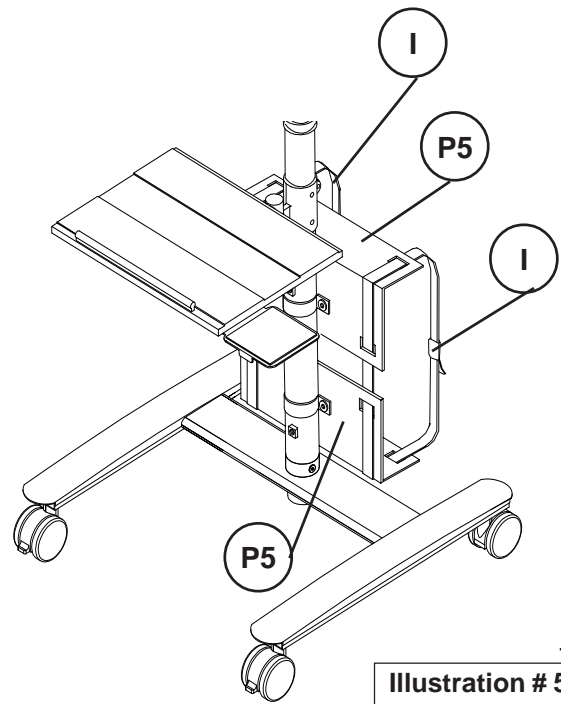

Illustration # 5a

- 7a.) Use two CPU Straps (I) through the slots in the CPU Mounts (P5) to secure your CPU in place. See illustration #5a.

27614_07-08-14

27614 Beta Cart

