

# ***Balt Mobile 20-Tub Storage Cart - 27754***

Instruction Manual



*Provided by*

**MyBinding.com**

*When Image Matters.*

Call Us at 1-800-944-4573

**27754**



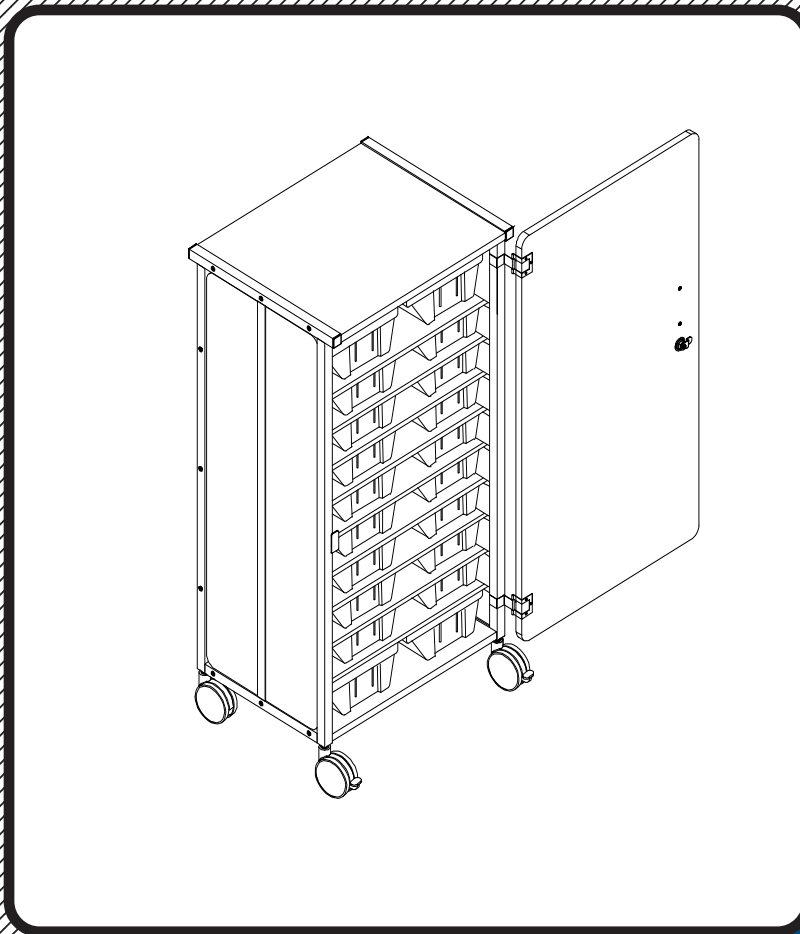







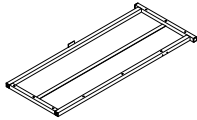
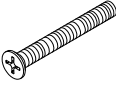
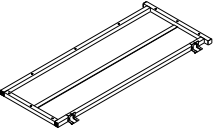
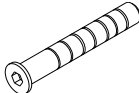
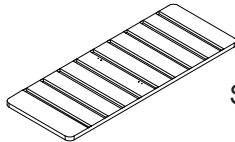

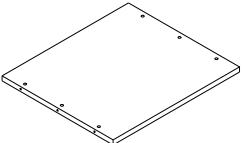

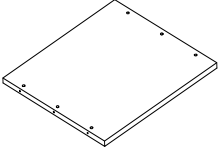
# **Mobile 20 Tub Storage Cart**

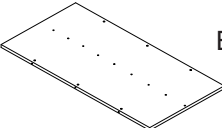

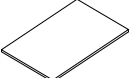

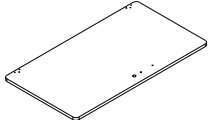

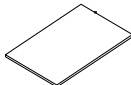
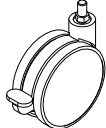
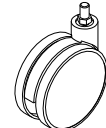
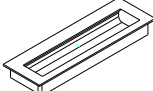



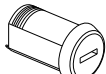

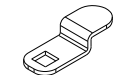
**Assembly Instructions**

#27754

# Mobile 20 Tub Storage Cart

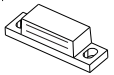
Part	Drawing	Description	Qty	Part	Drawing	Description	Qty
<b>Hardware List</b>							
P-1		Left Leg Welded	1 EA	A1		CS Phil Screw M6X50mm	18 EA
P-2		Right Leg Welded	1 EA	A2		Wood Screw M7x50mm	1 EA
P-3		Slotted End Panel	2 EA	A3		CS Wd Screw M3x12mm	6 EA
P-4		Top Panel	1 EA	A4		Phil Pan Screw M4x12mm (Door Handle)	2 EA
P-5		Bottom Panel	1 EA	A5		Pan Hd Screw M4x18mm	8 EA
P-6		Back Panel	1 EA	A6		CS Wood Screw M3x8mm	1 EA
P-7		Shelf	8 EA	B-1		Wood Dowel	9 EA
P-8		Door	1 EA	C		Lock Washer-Casters	4 EA
P-9		Middle Shelf	1 EA	D		4" Locking Caster	2 EA
				E		4" Caster	2 EA
				F		Door Handle	1 EA
				J		Middle Shelf Bracket	2 EA

Part	Drawing Description	Qty
<b>Hardware List</b>		
K1	 Lock Cylinder	1 EA
K2	 Lock Washer	1 EA
K3	 Lock Hex	1 EA
K4	 Lock Retainer	1 EA
K5	 ¼" Phil Head Lock Screw	1 EA
L	 Key	2 EA
N	 Caster Wrench	1 EA
P	 Allen Wrench	1 EA
Q	 Tube Closure	4 EA
R	 Magnet	1 EA
S	 Metal Plate	1 EA

# Assembly Diagram

## To Assemble:

1. Identify and Separate all the Parts and Hardware.

Illustration # 1

2. Attach Right Leg Welded (P2) to the Top and bottom Panels (P4 & P5) using 6 screws (A1) as shown in illustration #1.

3. Attach Back Panel (P6) to the Right Leg Welded (P2) using 3 screws (A1) as shown in illustration #1.

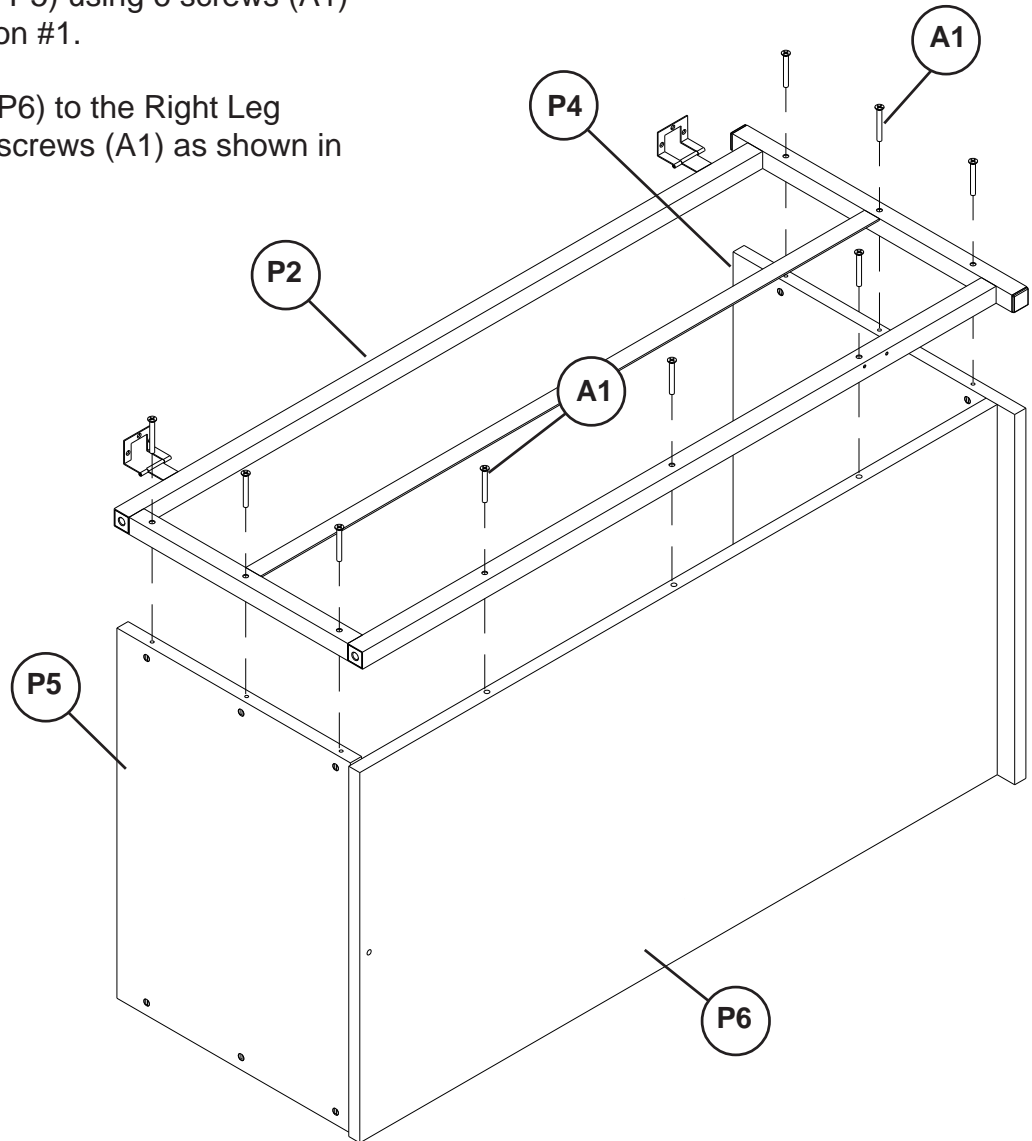

4. Attach the Back Panel (P6) to the Bottom Panel (P5) using one Screw (A2).

Illustration # 2

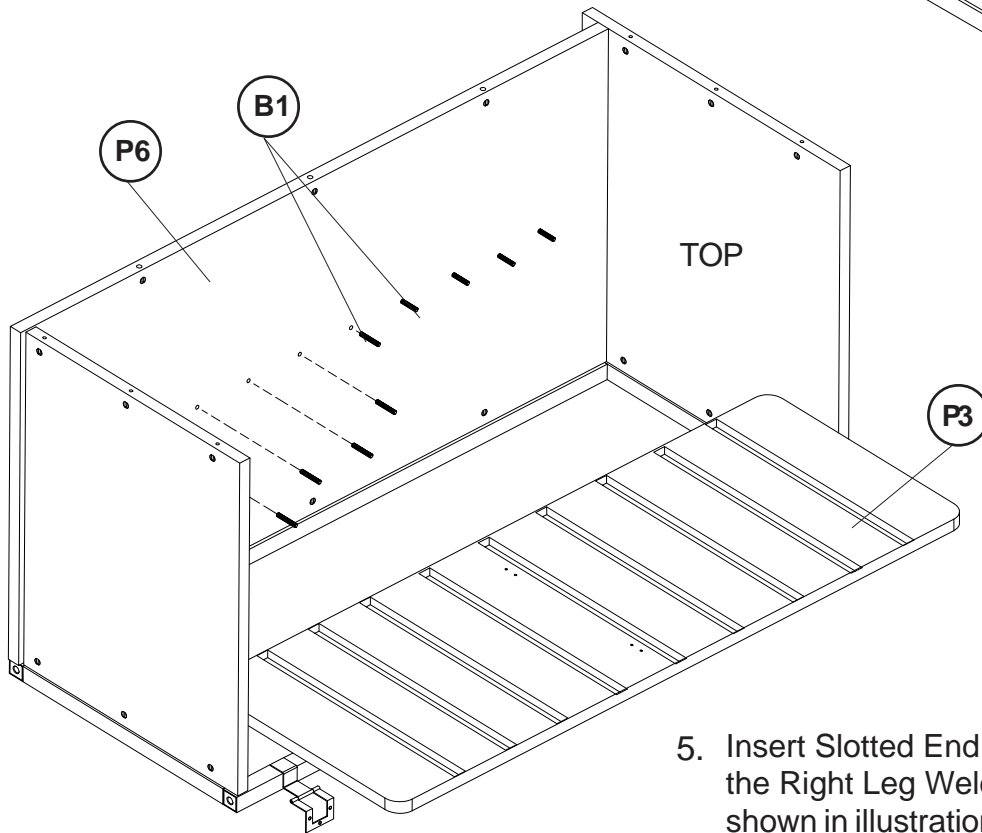
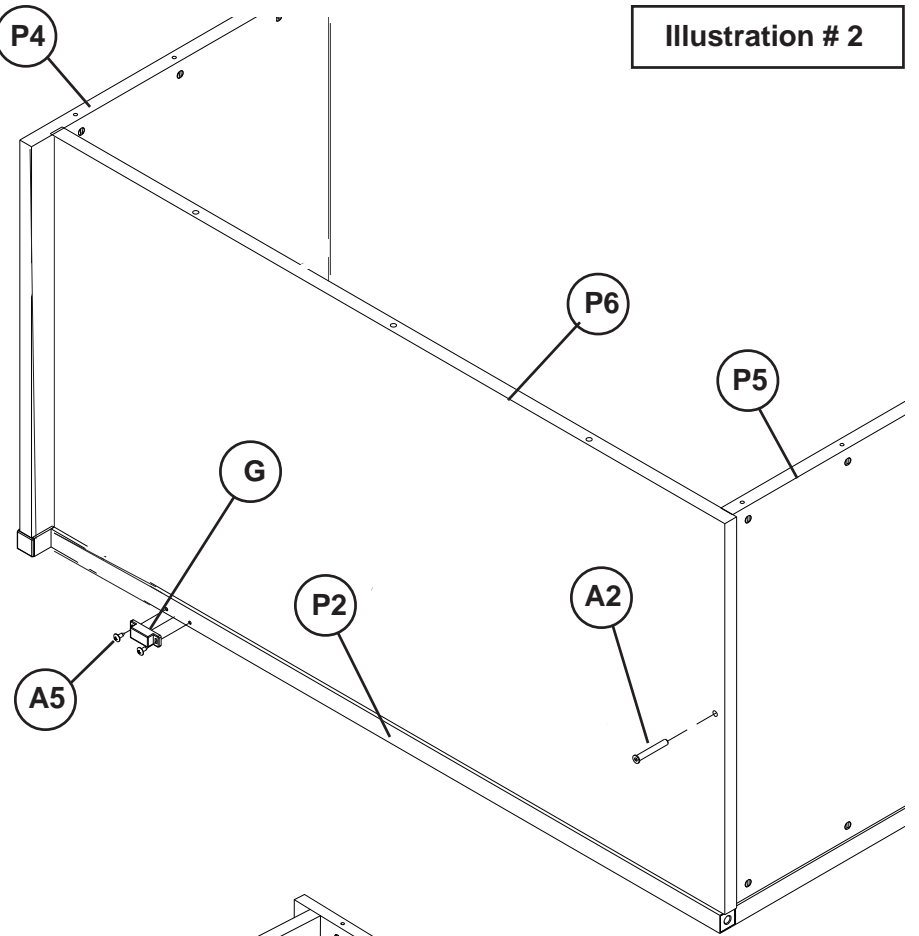
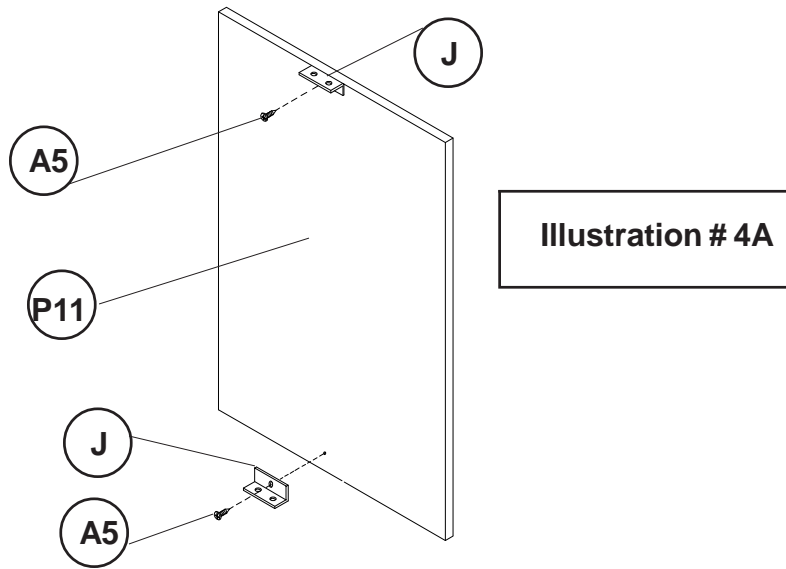

Illustration # 3

5. Insert Slotted End Panel (P3) in the Right Leg Welded as shown in illustration #3. Make sure the four predrilled holes are under the fifth slot from the top.
6. Insert 9 Wood Dowels (B1) in holes in the Back Panel (P6).

- Attach two Middle Shelf Brackets (J) to the bottom sides of the Middle Shelf (P11) using 2 CS Wood Screws (A5) as shown in illustration #4A.



- Place Middle Shelf assembly, from Step 8, in the fourth slot down from the top of Slotted End Panel (P3). Use 2 CS Screws (A5) to attach through the Middle Shelf Bracket (J) and into the Slotted End Panel's (P3) predrilled holes as shown in illustration #4B.

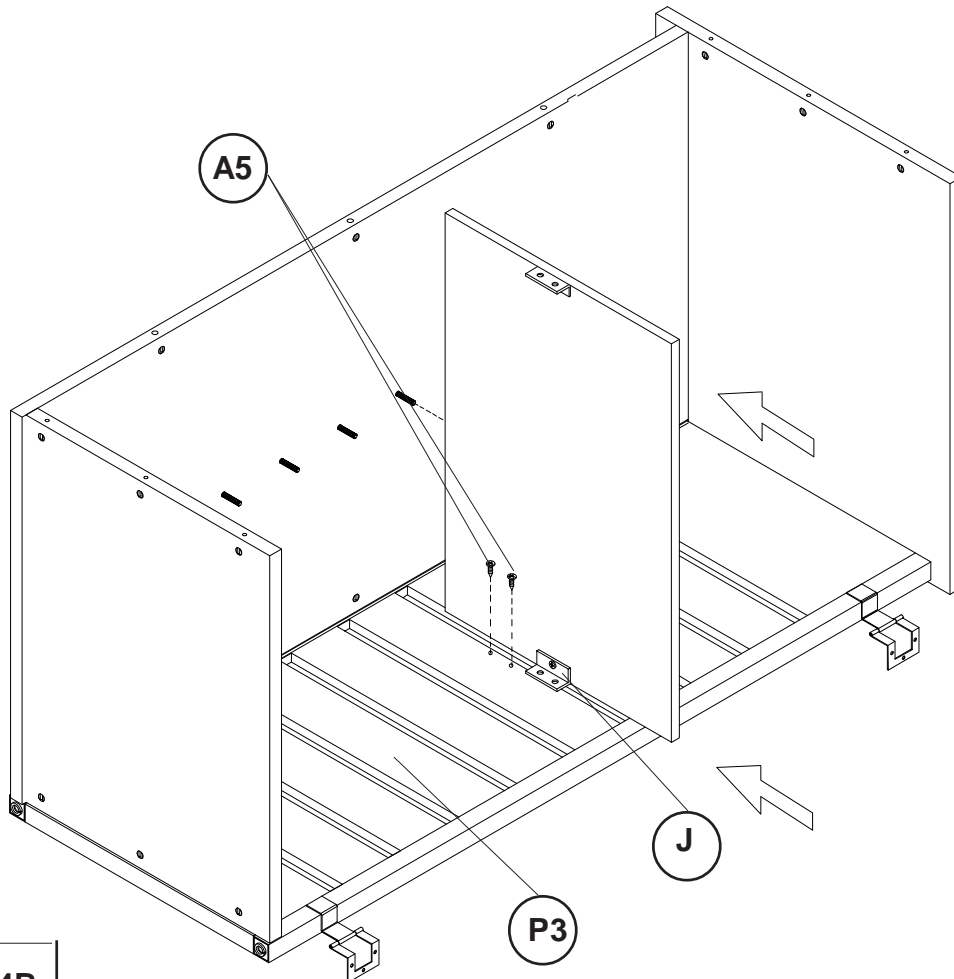

Illustration # 4C

9. Slide 8 Shelves (P7) over Dowels (B1) and into slots in Slotted End Panel (P3) as shown in illustration # 4C.

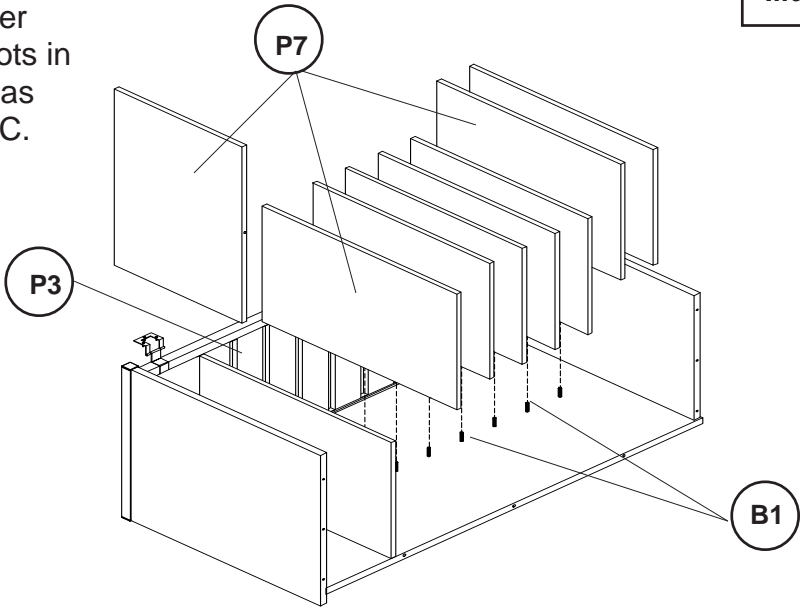
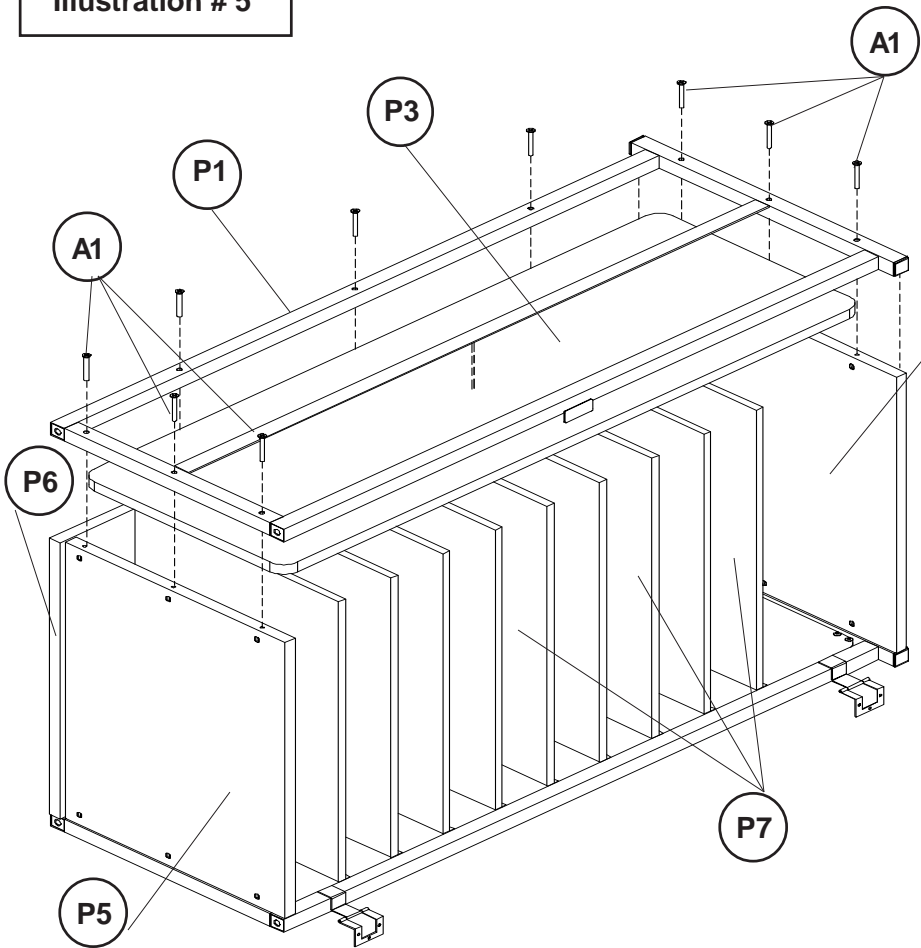

Illustration # 5



10. Place Slotted End Panel (P3) over the end of 9 Shelves (P7) as shown in illustration #5.

11. Attach Left Leg Welded (P1) to the Top and bottom Panels (P4 & P5) using 6 screws (A1) .

12. Attach the Left Leg Welded (P1) to the Back Panel (P6) using 3 screws (A1) as shown in illustration #5.



13. Attach 2 Locking Casters (D), and 2 Lock Washers (C) to the front of Welded Legs (P1 & P2).

Illustration # 6

14. Attach 2 Casters (E) and 2 Lock Washers (C) to the back of Welded Legs (P1 & P2). Tighten all Casters using Caster Wrench (N). Attach Bracket (J) that is under Middle Shelf (P11) to left (P3) End Panel using 2 CS Screws (A5) as shown in detail.

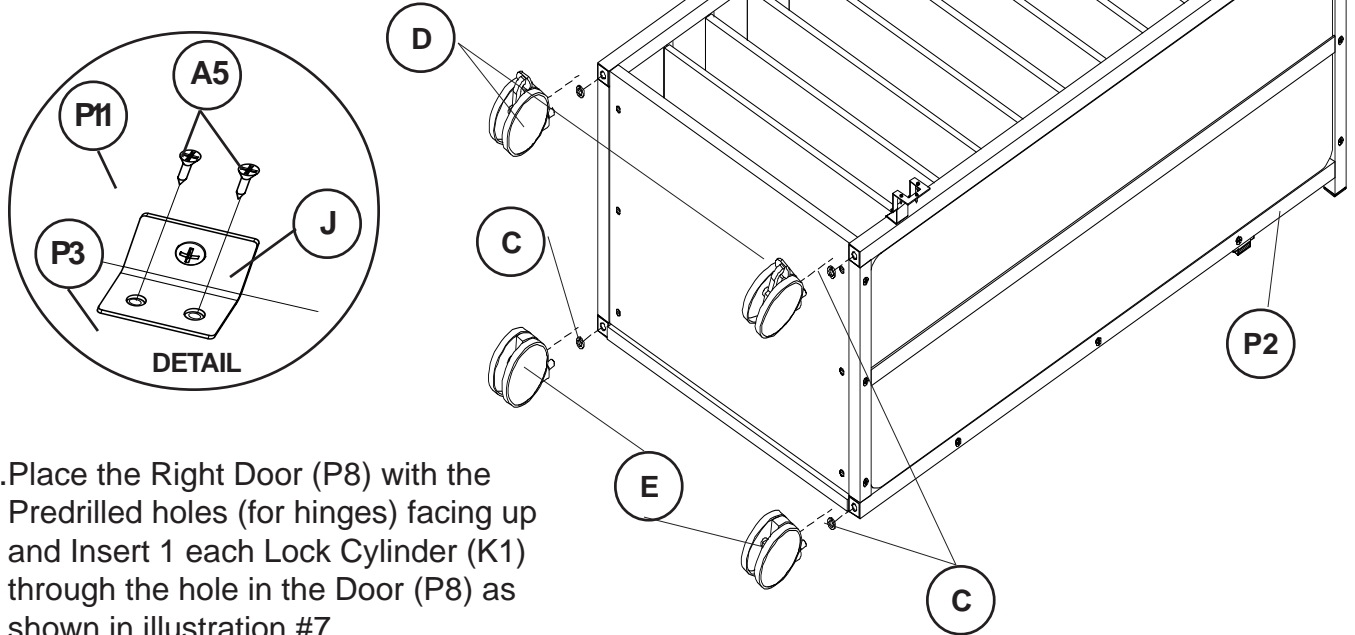

15. Place the Right Door (P8) with the Predrilled holes (for hinges) facing up and Insert 1 each Lock Cylinder (K1) through the hole in the Door (P8) as shown in illustration #7.

16. Secure Lock Cylinder (K1) using the Lock Washer (K2) and the Lock Hex (K3). (*FINGER TIGHTEN ONLY.*)

17. Slide Lock Retainer (K4) over the square end of Lock Cylinder (K1). Secure using the 1/4" Phil Head Lock Screw (K5).

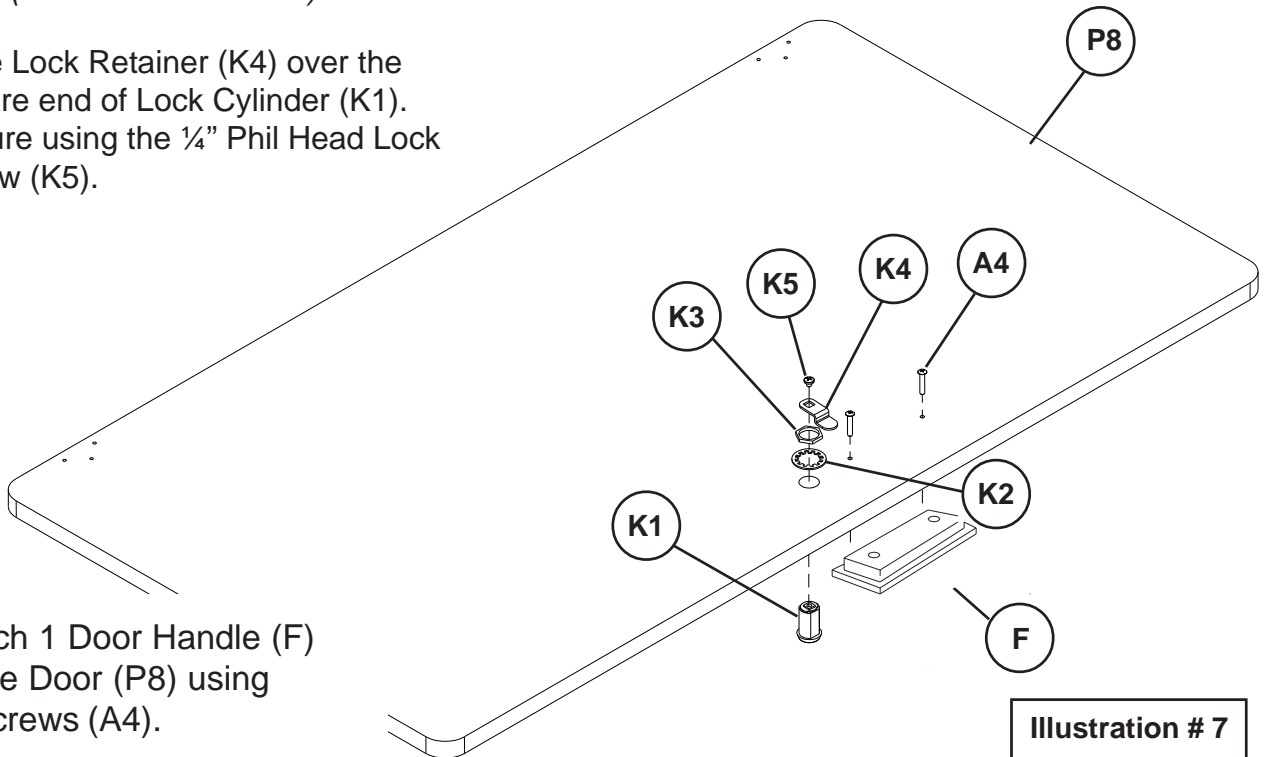
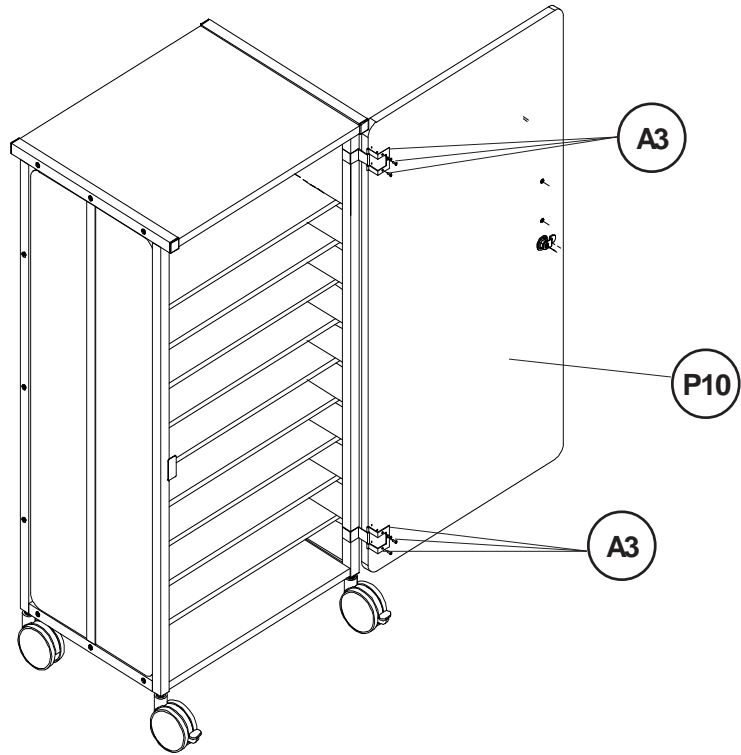

Illustration # 7

18. Attach 1 Door Handle (F) to the Door (P8) using 2 Screws (A4).

19. Attach the Right Door (P10) to the Right Leg Welded (P2) using three CS Wood Screws (A3) through each Door Hinge as shown in illustration # 8b.

Illustration # 8b



20. Before tightening the Lock Hex (K3), Insert the Key (L) and turn lock. Be sure that Lock Retainer (K4) turns 90 degrees and rotates behind Door Stop on the Left Leg Welded (P1).  
*TIGHTEN LOCK HEX (K3).*

Illustration # 8c

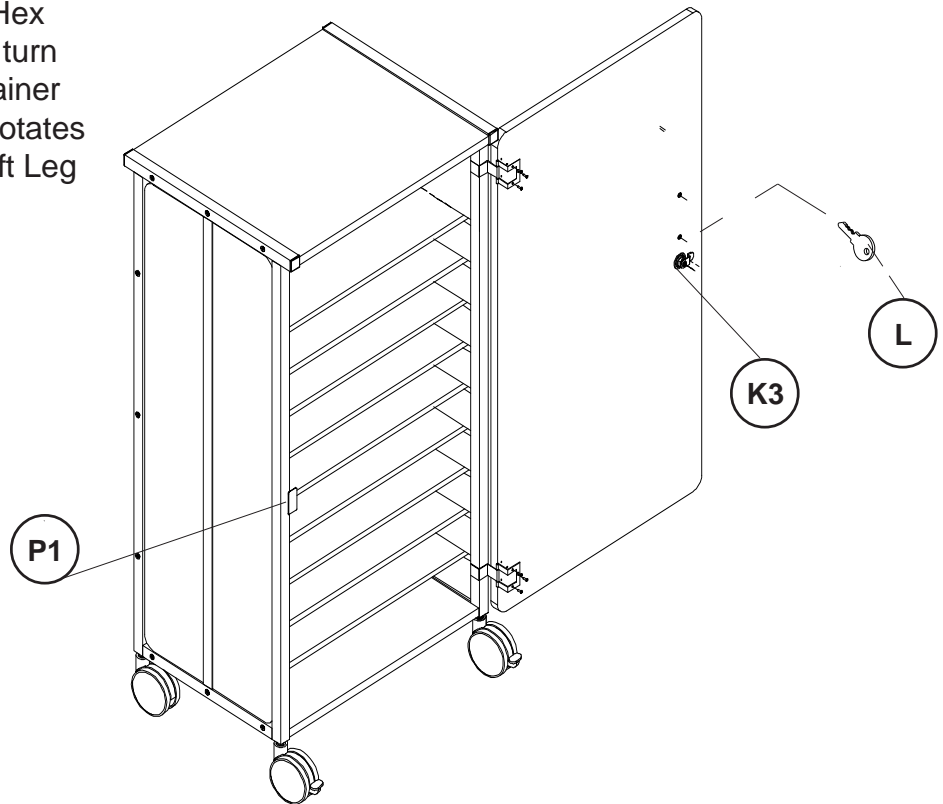

21. Attach the Metal Plate (S) to the front of the Door (P8) using one CS Wood Screw (A6) in the predrilled hole in the Door. Attach the Magnet (R) to the Right Leg Welded (P2) using two Screws (A5) into the predrilled holes near the top of the Leg. See illustration # 9.

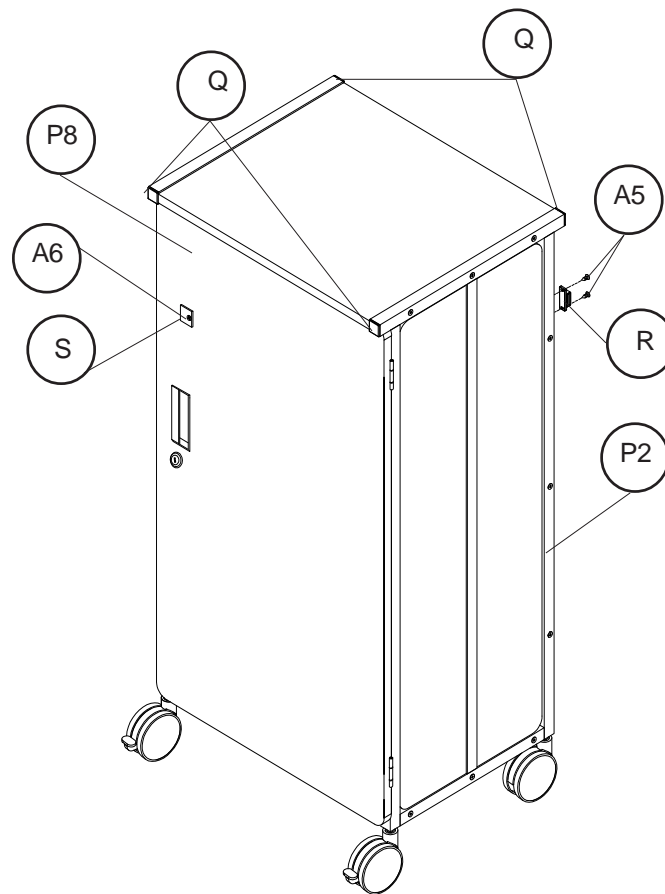

22. Push in four Tube Closures (Q) into the top tubes of the Right and Left Legs. See illustration #9

# 27754

## Mobile 20 Tub Storage Cart

