

Balt 4' x 3' Visionary Move Mobile Magnetic Glass Whiteboard

Instruction Manual



Provided by

MyBinding.com
When Image Matters.





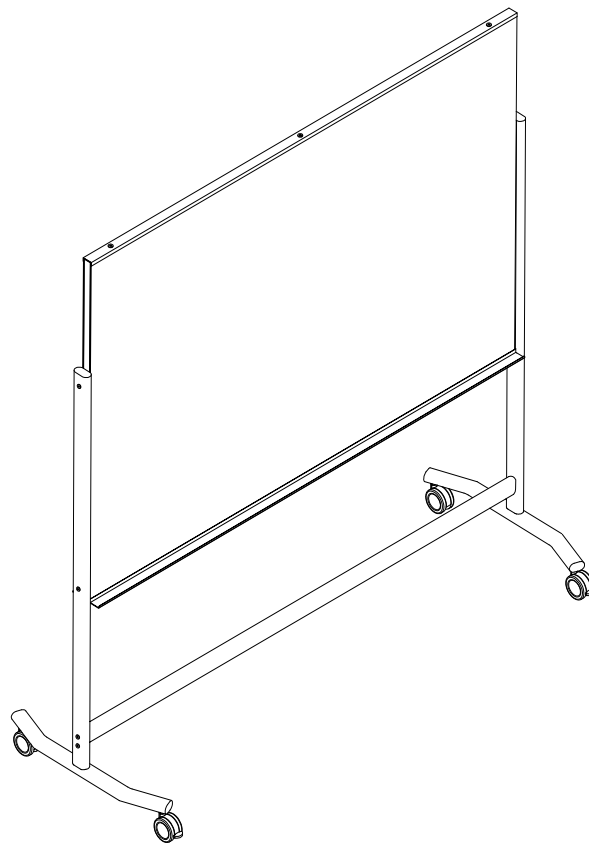

Call Us at 1-800-944-4573

Visionary Move

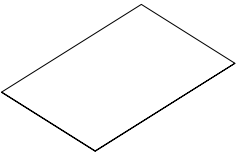
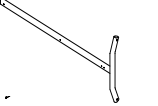
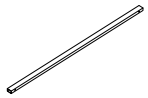
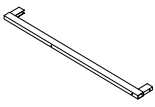
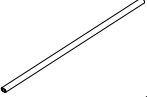
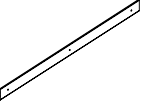

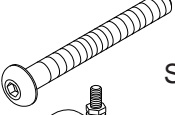
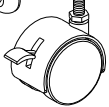
Assembly Instructions

Visionary Move

Part	Drawing	Description	Qty
<div style="display: flex; justify-content: space-around;"> <div style="border: 1px solid black; padding: 5px; display: inline-block;">Parts List</div> <div style="border: 1px solid black; padding: 5px; display: inline-block;">Hardware List</div> </div>			
P1		Glass Board	2 EA
P2		Leg	2 EA
P3		Horizontal Tube	2 EA
P4		Vertical Tube	2 EA
P5		Bottom Post	1 EA
P6		Tray	1 EA
P7		Top Cap	1 EA
A		Screw 1/4 X 15mm	6 EA
B		Screw 1/4X 50mm	8 EA
C1		Locking Caster	2 EA
C2		Non-Locking Caster	2 EA
D		Castor Wrench	1 EA
E		Allen Wrench	1 EA
F		Lock Washer	4 EA

NOTE: You will not use the Assembly Instructions or Hardware that are included in the Glass Board packages.

Visionary Move Assembly Diagram

READ THROUGH INSTRUCTIONS FROM BEGINNING TO END BEFORE STARTING TO ASSEMBLE UNIT.

To Assemble:

- 1.) Identify and Separate all the Parts and Hardware.
- 2.) Place a Lock Washer (E) on each Caster's stem and screw in one Locking Caster(C1) and one Non-Locking Caster (C2) into the bottom of each Leg (P2). Tighten Casters with Caster Wrench (D) as shown in illustration #1.

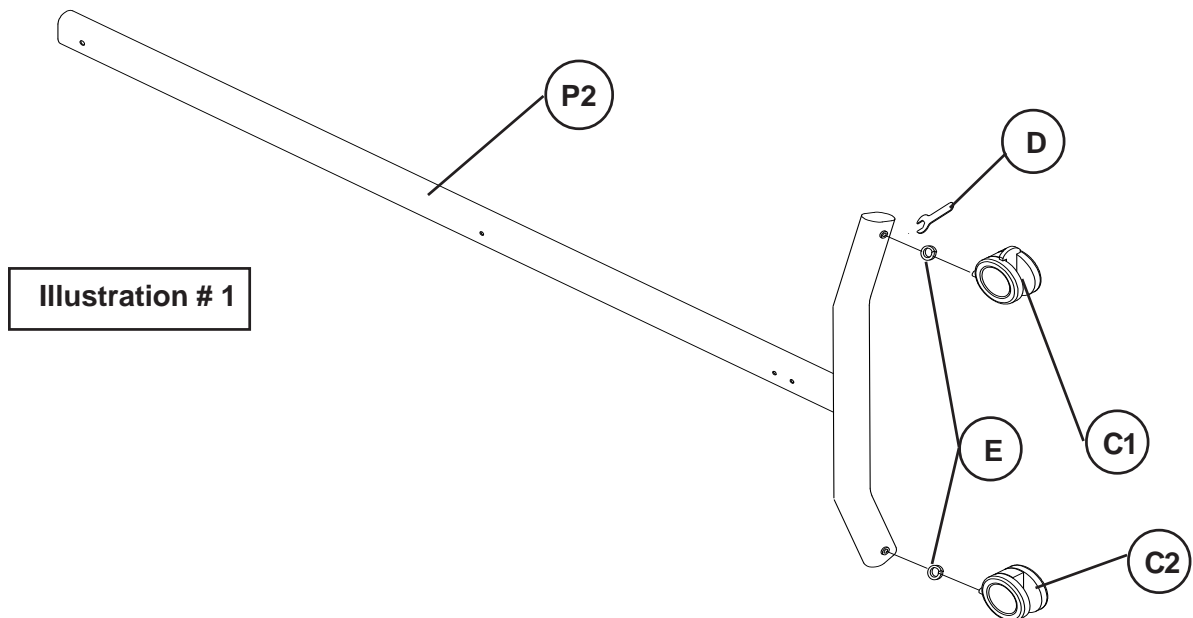

- 3.) Attach the Bottom Post (P5) in between the Legs (P2) using two Screws (B) for each as shown. Make sure the feet on the Legs(P2) are point in to each other. Tighten Screws using Allen Wrench (E). See illustration #2.

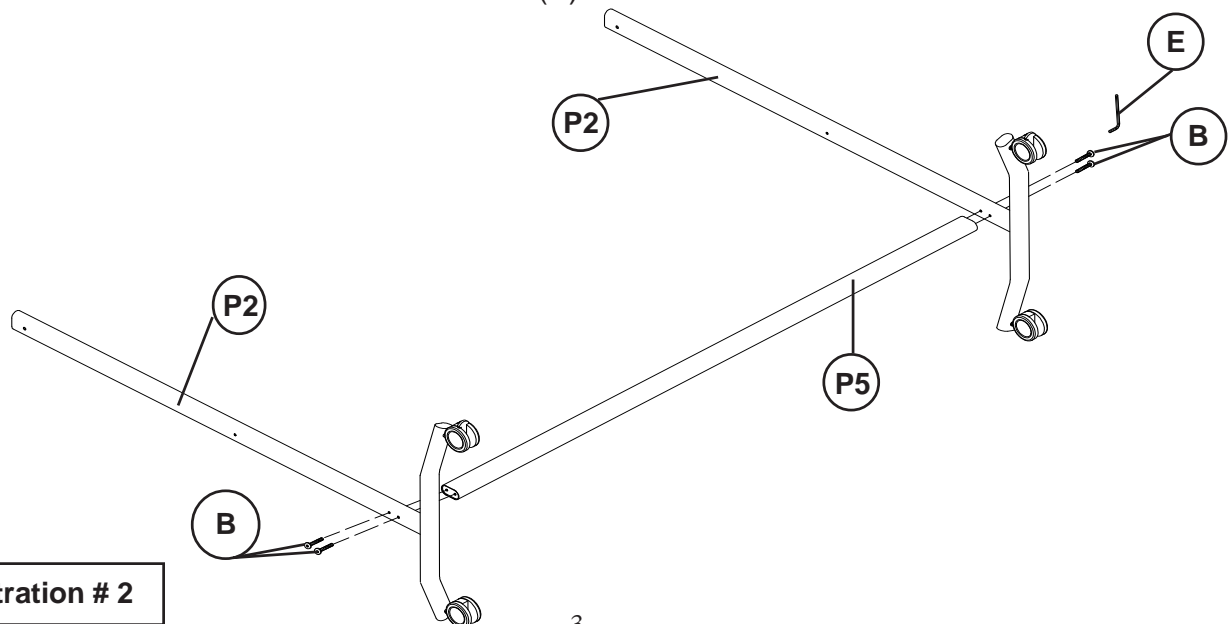

- 4.) Insert the Vertical Tubes (P4) into the Horizontal Tubes (P3) as shown in illustration #3. Make sure the holes in the Vertical Tubes are oriented as shown.

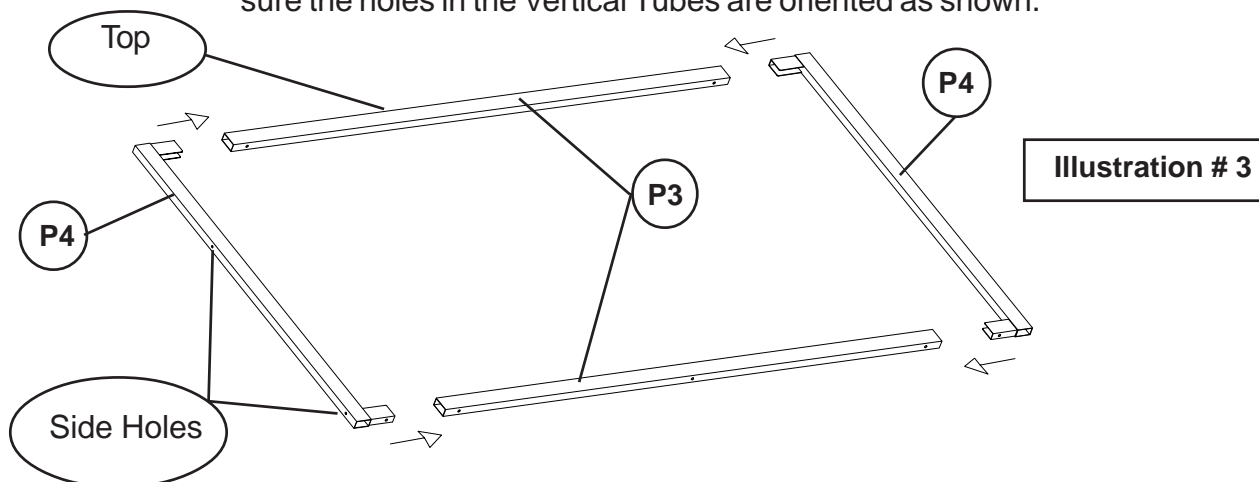

- 5.) Slide the assembly from Step 4 in between the Leg assembly from Step #3. Align the holes and connect using two Screws (B) through each side as shown in illustration #4.

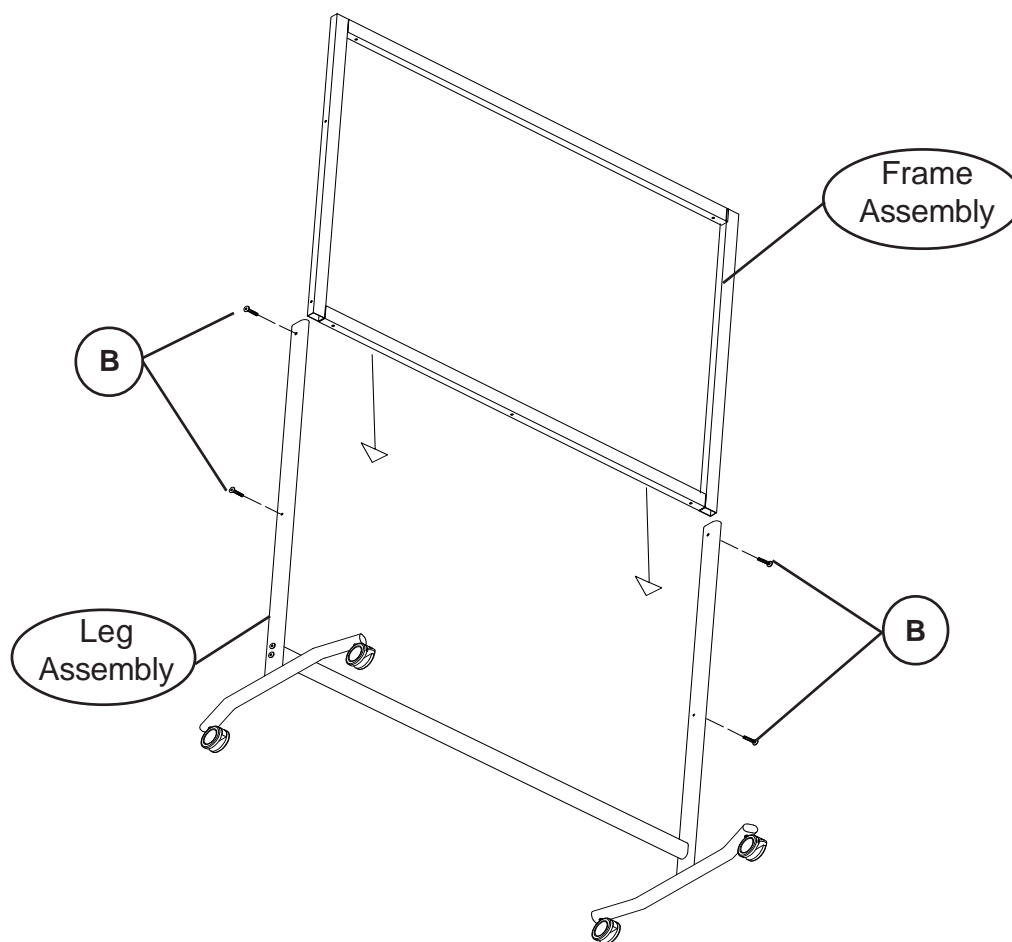

- 6.) Attach the Tray (P6) to the bottom of the frame assembly using three Screws (A). Tighten Screws with Allen Wrench (E) as shown in illustration #5.

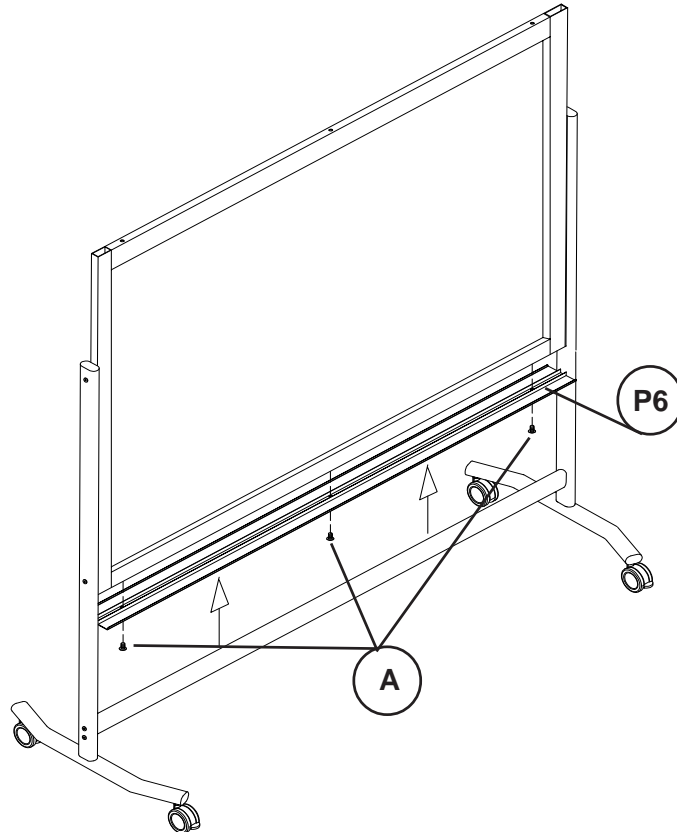

illustration #5

- 7.) Place a Glass Board (P1) into the Tray's (P6) inner flanges in front of the frame on both sides. Hold the two Glass Boards against the frame and lower the Top Cap (P7) over the top as shown in illustration #6. Secure the Top Cap (P7) to the top frame member using three Screws (A). Tighten all Screws using Allen Wrench (E).

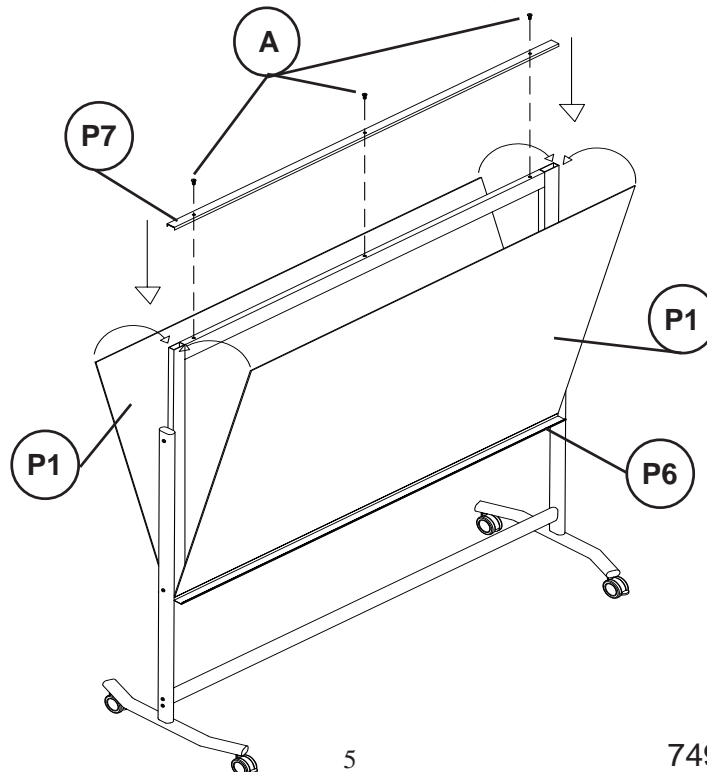

Illustration # 6