

Coverbind Perfect Binding Systems Operator's Manual

Issue 1 November 1, 2021

CPB1



CPB2SG



This manual is for all versions of the Coverbind Perfect Binders: Models CPB1, CPB2, and CPB2SG.

The CPB2 and CPB2SG sit on their own stand/cabinet which houses both the air compressor and the dust extractor. To turn on the Dust Extractor, locate the toggle switch on the front of the machine.

You can bypass the safety hood's sensor by using the supplied key(s) located near the Dust Extractor switch.

TABLE OF CONTENTS

GETTING STARTED	3
POWERING UP	8
CONTROL PANEL	8
SET UP	10
SETTING THE CLAMP LIMITER	11
ALIGN THE COVER STOCK	13
BOOK THICKNESS WHEEL & NIPPER ADJUSTMENT KNOB	13
SIDE GLUE ADJUSTMENT	14
ADJUSTING BINDING STRENGTH	15
STARTING PRODUCTION	16
MAKING PADS	16
DRAINING GLUE	17
MAINTENANCE	18
DAILY MAINTENANCE	18
WEEKLY MAINTENANCE	18
TROUBLESHOOTING	19
UNEVEN OR INCONSISTENT SIDE GLUE	19
ADJUSTING SIDE GLUE BETWEEN HEAD AND FOOT OF BOOK	20
ADJUSTING SIDE GLUE ON OPERATOR AND NON-OPERATOR SIDES OF THE BOOK	20
PAGES NOT BINDING WELL	21
ROUGHING BLADE AND NOTCHING PINS ADJUSTMENT (CPB2SG model has a mill blade)	22
UNEVEN CORNERS OF THE BOOK SPINE	23
LEVELING THE NIPPER TABLE	23
MACHINE DOES NOT CYCLE	24
MACHINE BEEPS TWICE IN RAPID SUCCESSION AND DOES NOT CYCLE	24
CLAMP IS STUCK / ERROR MESSAGE	25
SCHEMATICS	26

GETTING STARTED

Congratulations on your purchase of **THE COVERBIND CPB1, CPB2, or CPB2SG**. This machine will allow you to perfect bind any book up to 2-1/4" or 55mm thick.

CPB1 Model

Before removing the machine from the shipping crate, have a table ready that will support a minimum of 330 lbs. (150 kg).

Uncrate the machine and inspect it for any damage that may have occurred during transport.

Place the unit on the table; use of a lift truck is recommended.

Be careful to avoid injury.

An optional stand is also available.

CPB2 and CPB2SG

Use a forklift to lift the machine off the skid.

Keep the machine steady; it is very top heavy.

Make sure all four wheels have the stops in the up position before placing it on flat level ground.

Once the machine has been moved to its final position, lower the stops to prevent the machine from rolling.

Some parts may already be installed.

1. Remove the compressor from the box and stand on a solid surface.

Do not place the compressor in an enclosed area such as a cabinet unless it is well ventilated. The air filter should already be installed on the compressor but if not, locate it within the compressor box and install it onto the fitting (FIG #1). Do not over tighten.

The compressor shown may differ from the one which comes with the machine. The compressor on the right does not need oil.

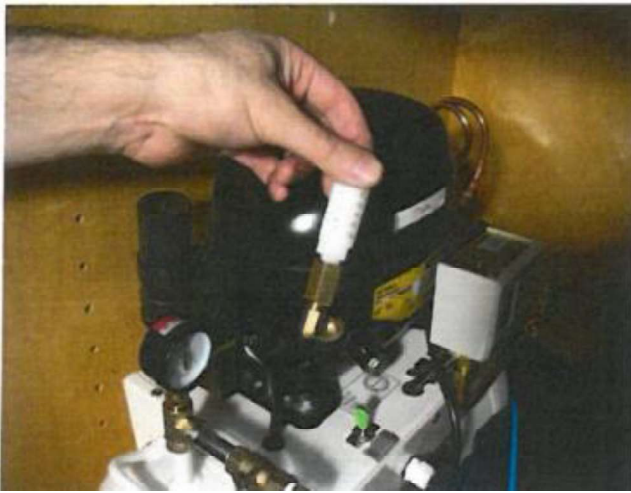

Figure 1

1. Plug the machine's power cord and the air compressor's power cord into the back of the binder. (FIG #2)

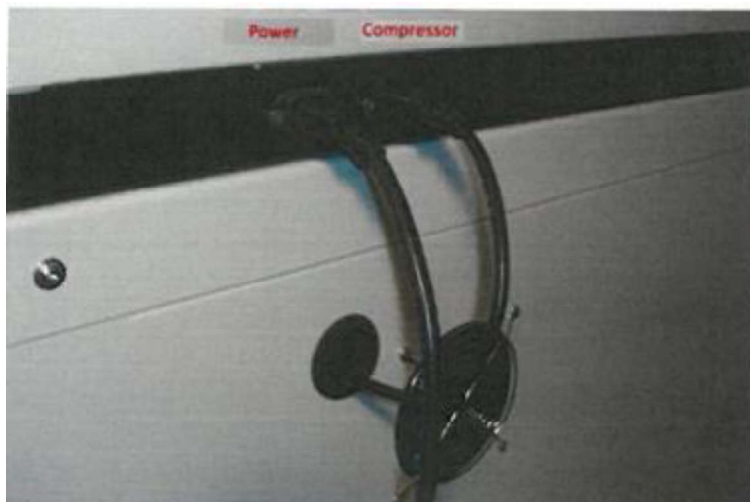

Figure 2

2. Install the exhaust fan. The exhaust fan is already on the CPB2SG models.
 - a. Start by attaching the connectors.
 - b. Press the connectors back into the exhaust box cavity along with any slack of the cord and install the exhaust fan on the machine.
 - c. Flip the exhaust box power switch on (FIG #3).



Figure 3

3. Plug the machine's blue air tube and supplied air gun into the "Y" air splitter. Then plug the air splitter's tube into the compressor (FIG#4).

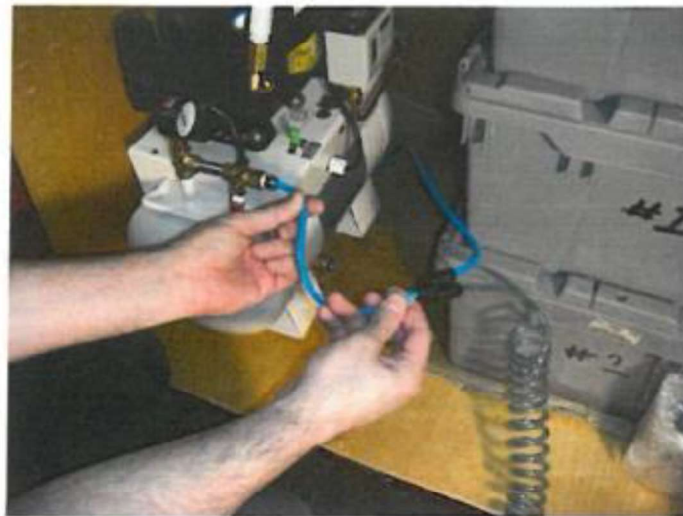

Figure 4

4. Open the valve on the compressor's pressure gauge (FIG #5) and turn the power switch to the on position. Make sure the bleed valve at the bottom of the compressor is closed (not shown) (FIG #5 - Arrow).

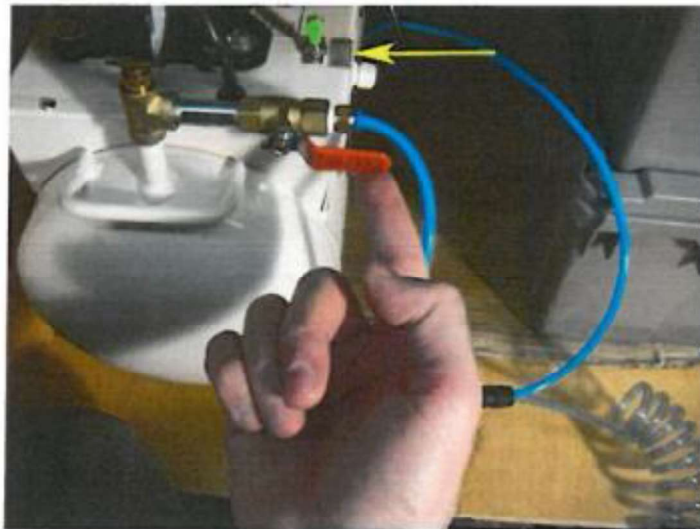

Figure 5



Figure 6

Figure 7

5. Attach the tall book guide to the top of the clamp. (FIG #6)
6. Install the book support. (FIG #7)
7. Install the rear table cover support behind the nipper table. (FIG #8)

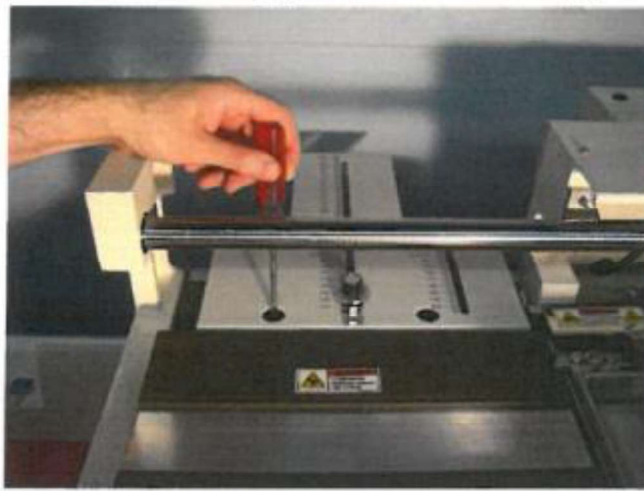

Figure 8

8. Screw in the nipper adjustment knob on the front of the nipper table.
(FIG #9)

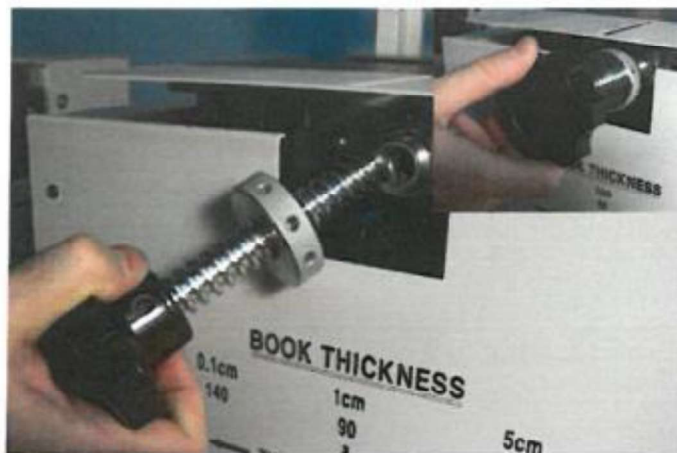

Figure 9

POWERING UP

1. Have your electrician check that your incoming power is 220 volts, single phase, 20-amp outlet. Have your electrician attach a plug onto the end of the machines Power cord that matches your socket.
2. The power switch is located on the right side of the binder. Turn on the machine and checked that the screen lights up along with a red LED indicating the gluepot heater is on and working.
3. Make sure the Emergency stop button is in the up position. If not, give it a gentle twist clockwise to release it.

CONTROL PANEL

The keypad controls the functions of the binder for operation, set up or troubleshooting.

The following is a list of the control buttons and switches (FIG #10).

1. **START:** This will cycle the binder fully through the binding process. This will not function unless there is a book in the clamp and cover stock on the nipper table.
2. **CLAMP:** Opens and closes the clamp. Use this feature for setting the clamp to the thickness of your book by utilizing the clamp limiter bar (more on that later).
3. **Green LED:** The machine will not cycle until the glue has fully melted and this LED is lit.
4. **UP:** Raises the glue temperature or increases the nipper's finish time.
5. **DOWN:** Lowers the glue temperature or decreases the nipper's finish time.
6. **Red LED:** Indicates that the glue heater is on.
7. **X:** Clears the functions of the glue rollers. Drops and opens the nipper table (if in the up and closed position), resets the batch count, and toggles the padding feature on or off.
8. **O:** Stand by. Lowers the glue temperature to 130 and prevents any function of the unit. **Also cycles the roughing motor/ sawblade if the binder is in the SET UP Mode.

9. **NIPPER CLOSE:** Close the nipper table. Press **X** to open.
10. **NIPPER UP:** Raises the nipper table. Press **X** to open.
11. **LEFT:** Moves the clamp to the left.
12. **RIGHT:** Moves the clamp to the right.
13. **CYCLE GLUE ROLLERS:** Use when adding glue. Glue should be approximately $\frac{3}{4}$ below the top of the gluepot.
14. **SET:** Pressing the UP or DOWN arrows on the 1st Screen changes the glue pot temperature. The counter on this screen cannot be reset.
 - a. Press SET once for the padding Mode Screen.
 - b. Press **X** to toggle padding on or off.
 - c. Press SET again For the Finish Time (Nipper Table dwell time).
 - d. Use the UP or Down arrows to set the Nipper Table dwell time. If Padding is on, each increment would add 10 Seconds. 15 would equal 150 seconds. If padding is off, 15 would equal 4 seconds.
 - e. Press SET a third time to get to the batch counter. This counter can be reset using the **X** button.
 - f. Press SET once more to return to the main screen.
15. **POWER SWITCH:** Located on the right side of the machine.
16. **TOGGLE SWITCH:** Turns the roughing motor on or off. The toggle switch is located below the Main power switch. Leave up for perfect binding or down for making pads.



Figure 10

SET UP

7. Turn on the machine to warm up the glue pot. The machine will not cycle until the glue has thoroughly melted. This should take approximately 45 minutes depending on glue and ambient air temperature.

During this time, the green LED will remain off and you cannot change the setting from the control panel. The temperature will rise above the set value then gradually lower to the set temperature.

2. When the machine is ready, the glue rollers will cycle, the machine will give 3 audible beeps and the green LED will light, indicating it is now ready for use.
3. At this time, you may adjust the temperature, if needed. We recommend 160 degrees centigrade (160°C = 320°F).

The machine will not cycle if the green LED is off (FIG #10, Item 3), without a book in the clamp (FIG #11) or cover stock on the nipper table (FIG #12).

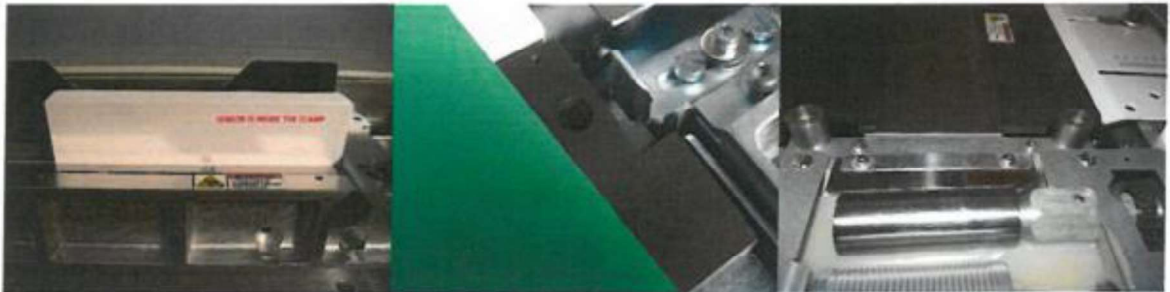

Figure 10

Figure 10

4. Put a cover in position on the nipper on the nipper table placing it square to the right stops (FIG #12) **(Round on the CPB2SG model)** with the rear edge tucked under the top stop guide. Loosen the top stop guide and adjust accordingly, depending on the size of the book. The rear of the book's spine will line up with the scored line in the nipper table. (FIG #13)

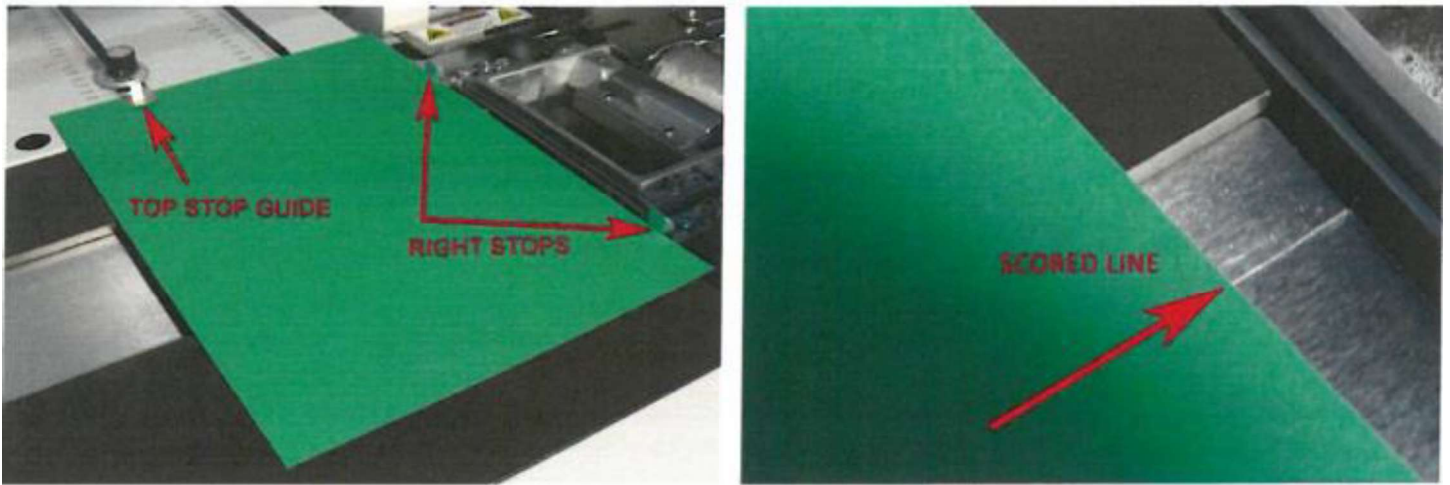

Figure 13

SETTING THE CLAMP LIMITER

1. Place the book block in the open clamp and jog it to the right, then press the CLAMP button.
2. After the clamp closes, move the Limiter Bar's pin into the second closet hole to the front, outside of the clamp. This will limit how wide the clamp opens so placing books of the same thickness will be easier and quicker.
3. Press CLAMP again to open the clamp. Check that the clamp's opening is approximately 1/4" wider than the book's thickness. This will ensure the clamp will not drag the book back after it has been bound. (FIG #14)



Figure 14

4. It is not necessary to continue to use the CLAMP button once the clamp opening is set. Simply place the book inside the clamp and jog it down and to the right so the pages are even.
5. Check that the cover is against both right stops and tucked under the back stop. Make sure the toggle switch below the main power switch is up. Also check that your Compressor is on and up to pressure and the pressure gauge's valve is in open position.
6. Keep your hand above the book to prevent any of the pages from "floating" up. The Clamp may squeeze air out from between the pages as it closes.
7. Press START to cycle the machine.
8. Lift the book off the nipper table as the clamp retreats. Inspects the book for Proper alignment of the cover, even corners of the spine and adequate glue for both sides of the book.
9. Do not open the pages yet. Allow time for glue to cool and harden.

ALIGNING THE COVER STOCK

CAUTION: THE RIGHT STOPS ARE VERY HOT!

To adjust the cover left or right, loosen and move the right stops left or right using Caution. Only loosen the hex screw in the center of each stop with the supplied 4mm T-handle Hex Key. Do not over tighten!

To adjust the Cover forward or back, loosen and adjust the Top Stop Guide (knob). (FIG #13 &14) The CPB2SG model may have round eccentrics and when loosened can be rotated which will move it left or right.

BOOK THICKNESS WHEEL & NIPPER ADJUSTMENT KNOB

The Book Thickness wheel (FIG #15) adjustment the upward pressure of the nipper table to Help produce a flatter spine.

For thinner books, rotate toward left. For thicker books, rotate toward right.

- Normally books under 1/4" would require a setting of 100 or higher.
- Half inch books should be set at 70.
- One inch or thicker should be set at 50 or slightly lower.

These are average settings. You may require more or less pressure depending on your stock and covers. You may also make use of the Nipper Adjustment knob to help produce square/sharper corners using the chart on the top plate of the nipper table (FIG #9).

Note, setting the nipper adjustment knob too tight may cause some sheets of the book to fold over. Simply open the nipper table further if this occurs. (FIG #9 and #15)



Figure 15

SIDE GLUE ADJUSTMENT

CAUTION: THE GLUE POT & EVERYTHING ON IT IS VERY HOT!

Make sure the glue level is within 3/4" from the top of the glue pot. Add glue chips as needed. Then try another book before making the following adjustments.

For more side glue on the non-operation side, loosen and move the Side Glue Wire closer to the rear side of the book.

For less side glue, move it further away from the rear side of the book. (FIG #16)

If you have the CPB2SG model, use the two sheet metal metering plates to adjust the amount of glue.

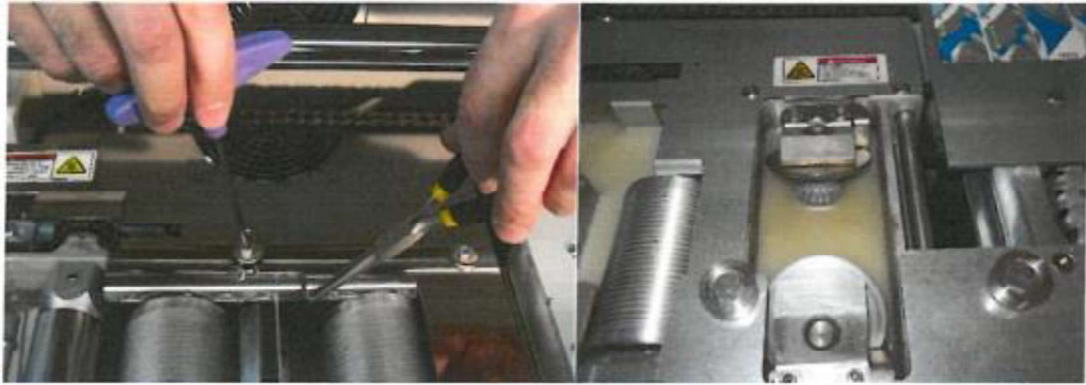

Figure 16

For more side glue on the operator side, you may need to adjust the glue pot's metering roller down. Adjust the metering roller by loosening the set screw with the supplied 3mm t-handle hex key then placing the tip of the hex key into any of the holes in the nut located near the glue pot's drive chain. Rotate it towards the left (lower) to apply more glue or towards the right (higher) for less. The book thickness wheel also affects the amount side glue that gets squeezed up. (Fig #17)

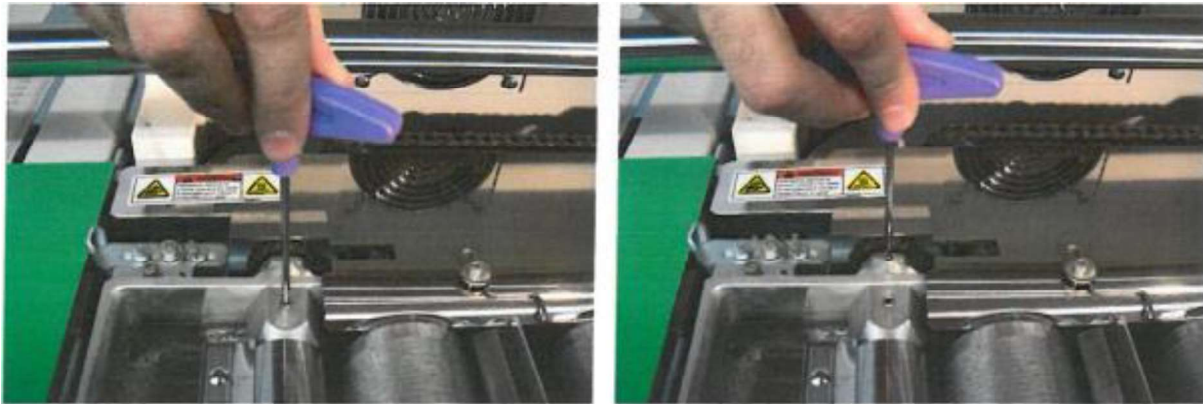

Figure 17

You may want to adjust the Nipper table's dwell time by pressing the set button twice until you reach FINISH TIME then press the up or down arrows on the right side of the Screen to increase or decrease how long the nipper squeezes the cover on the book.

NOTE: If the padding mode is on, 15 would equal 150 seconds. If the padding mode is off, then 15 would equal 4 seconds. We recommend setting the Finish Time to 15 for perfect binding books and 4 for pads. (More information for making pads is on page 13.)

Allow the book to cool completely before inspecting. Check that side gluing is to your satisfaction inside the front and rear covers. Refers to the troubleshooting

section starting on page 14 if these adjustments do not produce side glue to your satisfaction.

ADJUSTING THE STRENGTH OF THE BIND

Before adjusting the roughing wheel and/or notching pins, turn off the roughing motor by flipping the toggle switch off. Locate it below the main power switch.

Paper grain direction should follow along the length of the spine. This will add strength to your bind.

After the book has sat for 1 hour, you may check the binding strength. If the pages pull straight out easily, you may need to raise the notching pins or add more glue to the spine by lowering the Metering Roller or adjusting the Book Thickness Wheel.

The Roughing wheel should not need to be adjusted. They are set to rough—not cut—the pages.

The Notching pins can be set higher for certain heavier/ glossier stock that tends to repel the Glue. When raising the Notching pins, do not allow them to cut ore that 1/16” into the book. Also make sure they do not hit the guards. Please refer to the troubleshooting section starting of this manual for more details.

STARTING PRODUCTION

1. Once the settings are to your satisfaction, place the next book block into the clamp and jog it down and toward the right.
2. Place the cover stock squarely on the nipper table with the rear edge tucked under the Top stop Guide.
3. Then press START.

If you have a **CPB2** or **CPB2SG**, turn on the vacuum motor on by lifting the green toggle switch on the front of the machine.

MAKING PADS

1. If you are making pads, be sure to flip the toggle switch below the main power switch down to turn off the roughing motor.
2. Press the SET button for the PADDING MODE screen then press X toggles it on or off. Padding on will disable the Nipper Table and the cover stock sensor.
3. Press SET again then UP or DOWN arrows to set length of the finish time.

NOTE: If the padding mode is on, 15 would equal 150 seconds. If the padding is off, then 15 would equal 4 seconds. Press SET twice to return to the temperature screen.

TIP: If you prefer using the nipper table for pads, leave the padding feature off and block the sensor on the nipper table. Use of any non-stick spray is recommended to prevent glue from sticking to the table.

***Note:** Standard Coverbind Glue is recommended for padding operations. Do not make pads while using Premium Coverbind Glue. Sometimes the entire roughing notching assemble needs to be lowered to avoid marks on the pad or book block jam.

DRAINING GLUE

After a period of time, the glue may get dirty or burnt or you may need to change the type of glue you are using. To drain the glue:

1. Remove the front panel, being careful not to damage the control panel wires, to locate the drain.

2. **USE CAUTION: Drain chute, Allen screw, and glue are extremely hot!** Place a box under the drain chute and remove the Allen screw.
3. When the glue has been drained you may melt wax in the glue pot to remove any excess glue and clean out any paper dust at the bottom. (FIG #18)

Note: There are two drain plugs on the CPB2SG model.

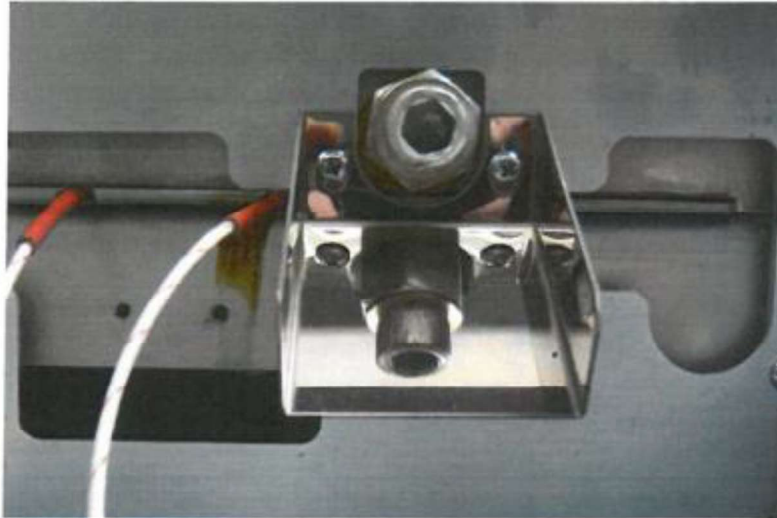

Figure 18

MAINTENANCE

DAILY MAINTENANCE

- The glue level in the pot will go down as books are bound. Glue chips should be used to replenish the pot, as needed.
 - If you see a dry spot or large air pocket on the center glue roller, add more glue. The level of the glue should rise to about 3/4" below the top of the glue pot.
 - The CPB2SG model has a level indicator in the main glue pot. The side glue pot glue level should be set at around the top of the bevel gears.
- **Do not leave the machine powered on when not in use.** This will cause the glue to burn and darken.
 - If reheating is too time consuming, press the **O** button to put the machine into **Stand-By** mode. This will lower the glue temperature. Press **O** again to resume.
- Use the supplied air gun to blow paper dust away from the glue pot.
- **The front and rear shafts must be cleaned regularly** to allow smooth operation of the clamp. Solvents or penetrating oils may be used to remove any glue residue. The shafts must be clean and slick so the clamp doesn't get bogged down or stuck during operation.

WEEKLY MAINTENANCE

- Check that the Notching Pins are sharp to avoid straining of the roughing motor and to ensure clean notching for adequate glue penetration. When replacing dull Notching pins, follow the instructions in the Troubleshooting Section of this manual under ROUGHING BLADE & NOTCHING PIN ADJUSTMENT.
- **Air compressor:** The compressor should be bled weekly to remove moisture build up inside the tank. The bleed valve is located at the bottom of the compressor tank.
- Check the oil level in the sight glass of the compressor motor. If oil is not visible or low, add air compressor oil into the motor's tube by removing the rubber cap (opposite side from the filter). Make sure the compressor is off when not in use. **Some compressors do not require oil.**
- Also check that the filter isn't clogged. To avoid overheating, do not operate the compressor in an enclosed area and check for air leaks periodically.

TROUBLESHOOTING

Some adjustments require the unit to be in the SETUP mode. This is done by turning off the unit then, while holding down the CLAMP button, turning the power back on.

****Note:** The machine will cycle continuously if the START button is pressed. Press and hold the X button while the clamp is traveling to the right to stop the cycling or press the Emergency stop button.

Also, while in setup Mode, the O (Stand By) Button will turn on the roughing motor. Pressing the X button will stop the motor. **Flip the toggle switch below the Main power switch to turn off the Roughing Motor.**

CAUTION: Pressing the RIGHT arrow button will close the roughing blade guard. To reset the machine back to normal operation, simply turn machine off on again.

UNEVEN OR INCONSISTENT SIDE GLUE

Make sure the glue pot has enough glue. While the rollers aren't cycling, the glue level should be about 3/4" below the top of the glue pot.

Check that the Air compressor is on and up to pressure. There should be between 90-110 psi.

You may also need to level your nipper table. See Leveling the Nipper Table on page 16.

The CPB2SG model has its own side glue tank. There are side glue metering plates next to each wheel. These plates can be moved in and out to allow for more or less glue to be applied to the book.

ADJUSTING SIDE GLUE BETWEEN HEAD AND FOOT OF BOOK

1. Put the unit in SETUP Mode. The clamp will close and the roughing blade's guard bracket will open.
2. Open the clamp and place a cover sheet in it, making sure the bottom doesn't curl as the clamp closes.
 - a. Close the clamp and jog it, using the left and right arrow buttons, back and forth over the Glue pot's Metering roller.

- b. Check the distance from the bottom of the cover stock to the roller, the cover stock must be the same distance above the roller from the leading edge to the trailing edge.
3. Locate the screw on the topside of the register table where you place the books. Level one end of the register table by turning the screws clockwise to lower or counterclockwise to raise it using a 5mm hex key.
4. Reset the machine back to normal operation simply by turning the machine off then on again after completing adjustments, then test by binding a book. If the table is leveled but the side gluing still isn't even, you may need to level the nipper table. See Leveling the Nipper Table below.

ADJUSTING SIDE GLUE ON OPERATOR AND NON-OPERATOR SIDES OF THE BOOK

CAUTION: BURN HAZARD.

Because the rear nipper table comes in before the front table does, more glue is channeled towards the front of the book. Adjust the Metering roller until you have enough side glue between the cover and the 1st page of the book (operator side).

Then locate the side glue wire on top of the far-right glue roller. Press the **Emergency Stop** button.

Loosen the screw. Using a pair of needle nose pliers, move the side Glue Wire slightly closer to the book to apply more or further away for less side glue between the cover and last page (non-operator side) of the book.

Release the Emergency stop button by giving it a gentle twist clockwise.

The CPB2SG model has a side glue pot. Both side glue wheels have a scraper which will adjust the amount of glue left on the book block.

PAGES NOT BINDING WELL

The glue needs time to cool and harden. Let them sit 1 hour before checking the binding strength.

If the pages still come out too easily then it may need deeper roughing and/ or notching, more glue, more nipper pressure, a longer nipper dwell time or special glue for your product.

TIP: The grain direction of the paper and cover stock should follow the length of the book's spine. This will improve the binding strength by as much as 25%. Fold the stock in half, length wise then width wise, and see which fold looks cleaner/smoothed. The smoother fold is the grain direction. You may also try one of these other solutions:

1. Increase the nipper finish time. Press the SET button twice to get to the Finish Time screen. Use the UP arrow button to increase the Finish Time.
2. Increase the nipper pressure by slightly turning the **book thickness wheel** to the left. Be sure not to use too much pressure. This will squeeze out the glue from the spine or cause "nail heading".
3. Increase the amount of glue being applied by lowering the far left glue metering roller. The glue level in the pot will go down as books are bound. Glue chips should be used to replenish the pot as needed. If you see a dry spot or large air pocket on the center glue roller, add more glue. The level of the glue should rise to about 3/4" below the top of the glue pot.
4. Pull a page out of the book and check the depth of the notches. If they are barely visible then you need to raise the notching pins. Adjust the roughing and notching. (See Roughing Blade and Notching Pin Adjustment below) Heavier stock or coated materials need deeper notching and a longer nipper finish time. *Note: Notching pins must be sharp!

ROUGHING BLADE AND NOTCHING PINS ADJUSTMENT **(CPB2SG model has a mill blade)**

1. Remove the operator side guard from the top of the roughing blade.
2. Put the unit in SETUP mode as described at the beginning of this Troubleshooting section. **Turn off the Roughing motor** by flipping the toggle switch below the main power switch.
3. Remove the front panel/guard. Be careful not to pull the wires of the display/control panel board.
4. Open the clamp and place a cover sheet in it, making sure the bottom doesn't curl as the clamp closes. Close the clamp then jog it over the roughing blade using the left and right arrow buttons. **Press the Emergency Stop Button.**

5. Loosen the setscrews locking the roughing blade assembly to the motor's shaft (under the blade assembly) with the supplied T-handle hex key. (FIG #19)



Figure 19

6. Adjust the roughing blade's height so that the tips of each tooth just lightly touch the pages. Lock the setscrews once the correct height is set. **The CPB2SG model has a dial so the book block can be adjusted up or down to remove more or less material. The notching pins still need to be adjusted independently. Fig 20, right side picture.**

7. Adjust the notching pins so that it goes no more than 1/16" into the pages. Loosen set screws on the outside of the roughing blade assembly with a 2.5mm hex key. You may need to raise it a bit more for heavier or coated stock. *Note: The notching pins may fall out once the setscrews are loosened. (FIG #19)



Figure 20

8. Install the blade's guard and check that the roughing blade and notching pins do not interfere with the guards by turning the blade by hand.

9. When you are done adjusting, turn the machine off then on again to return it to normal operation. Install all guards and release the Emergency Stop button.

UNEVEN CORNERS ON THE BOOK SPINE

Make sure the compressor is turned on, up to pressure and the Air Compressor's valve where the machine's air hose is connected is in the fully open position. Make sure the bleed valve at the bottom is fully closed. The pressure gauge's needle should point approximately .75 MPa or 110 PSI (between 11 and 1 o'clock). Make sure the air hose isn't pinched or kinked.

If you have the correct air pressure and the corners still aren't even, then you may need to level the nipper table. If one or both ends of the book have very sharp corners, try lowering the book thickness wheel a bit.

LEVELING THE NIPPER TABLE

1. Press the 1st and 2nd buttons on the control panel (top left buttons) to raise and close the nipper table. Remove the small front white cover stock support tray.
2. Remove Rear Table Cover Support only if you need to adjust the rear right side of the nipper table. You can adjust the rear setscrew on the left side without removing this tray.
3. Loosen 2 locking screws at the corner you want to adjust with the supplied 4mm T-handle hex key.
4. Turn the adjustment setscrew with a 2.5 mm hex key clockwise to raise or counterclockwise to lower that corner. *Note: You should adjust the front and rear (operator and non-operator side) set screws the same amount on either the left or right side of the nipper table. When lowering a corner, press down slightly on that corner while tightening the two 4mm locking screws. (FIG #19)

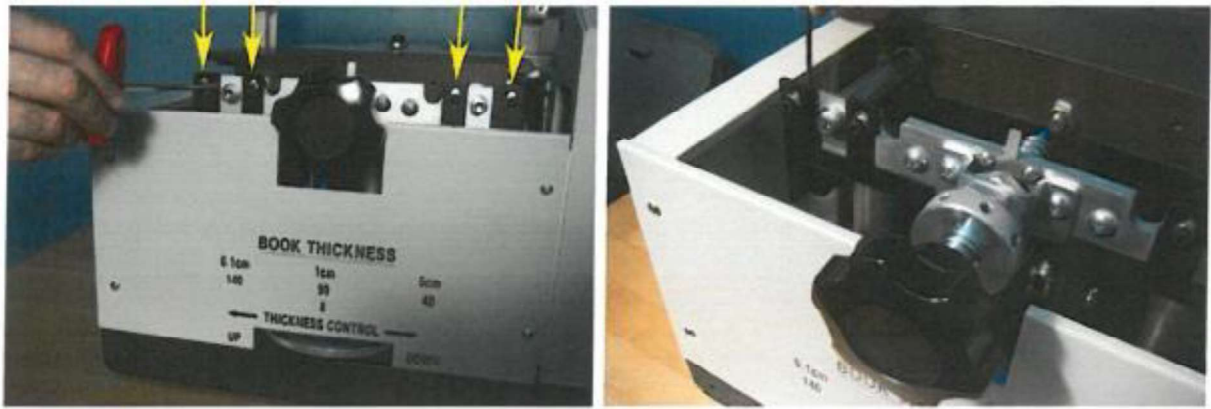

Figure 21

MACHINE DOES NOT CYCLE

Make sure the machine is up to temperature and the green lamp on the control panel is lit. It takes approximately 45 minutes to reach operating temperature before it will allow you to operate.

Check that the Set temp and actual temp are over 130 degrees Celsius.

MACHINE BEEPS TWICE IN RAPID SUCCESSION AND DOES NOT CYCLE

Make sure the book is in the clamp and a cover sheet is on the nipper table and both are jogged all the way to the right and blocking the sensors. Some dark stocks may not activate the sensor(s).

CLAMP IS STUCK / ERROR MESSAGE

Most problems can be solved over the phone but you may need to schedule a service call. **Write down the error message and machine serial number and call your dealer.**

The front and rear shafts must be clean and slick, or the clamp will get stuck. It is recommended that you clean the shafts daily. You may use solvents or penetrating oil to clean any paper dust or glue residue from the shafts.

SCHEMATICS

CPB1 Electrical Schematic

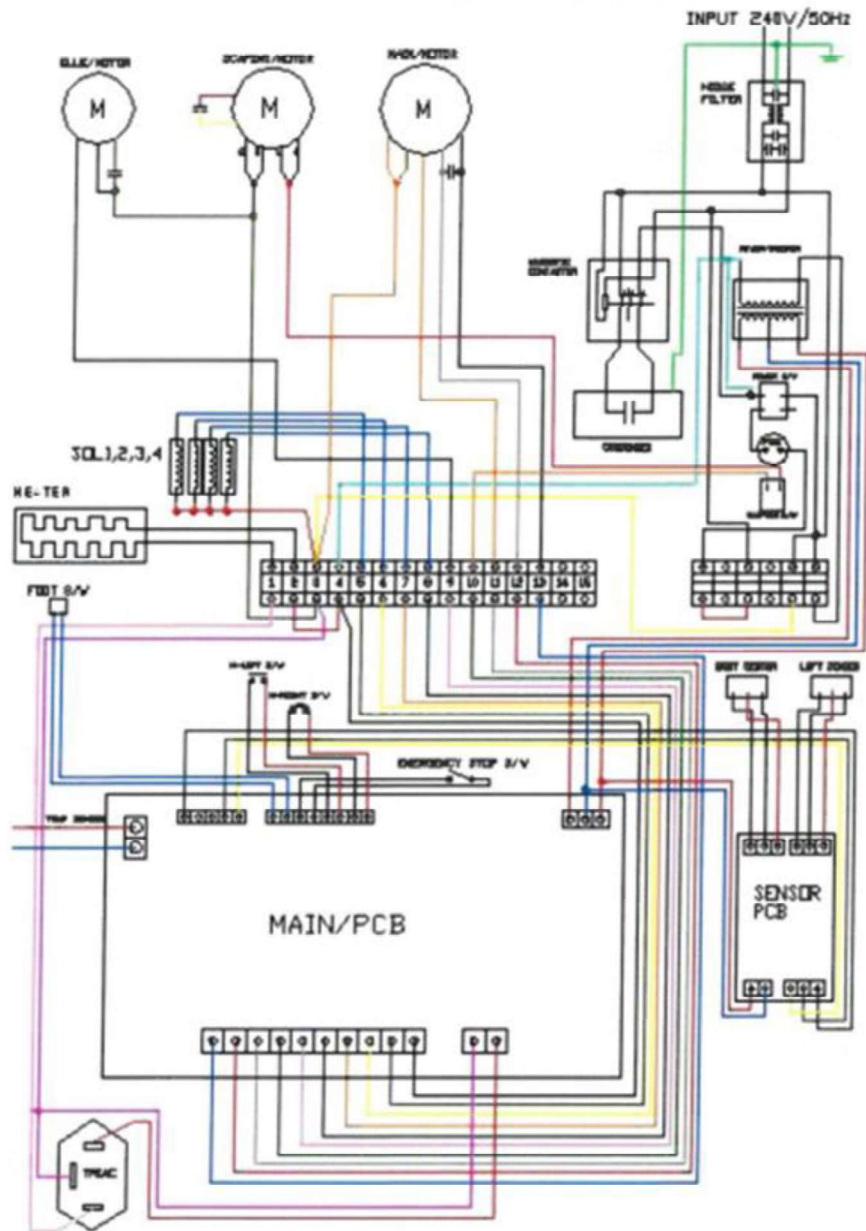

CPB2 Electrical Schematic

