

Foster



On-A-Roll Lifter®

Instruction Manual for Low Profile Models

Read Before Use!

Important instructional, safety and precautionary information!

It is the user's responsibility to exercise good judgment, common sense, safety measures and reasonable limits regarding the use of the On-A-Roll Lifter® so as not to incur risk to the user or damage to the materials being carried. In order to obtain maximum benefit from your machine, please read these instructions carefully before using the On-A-Roll Lifter®.

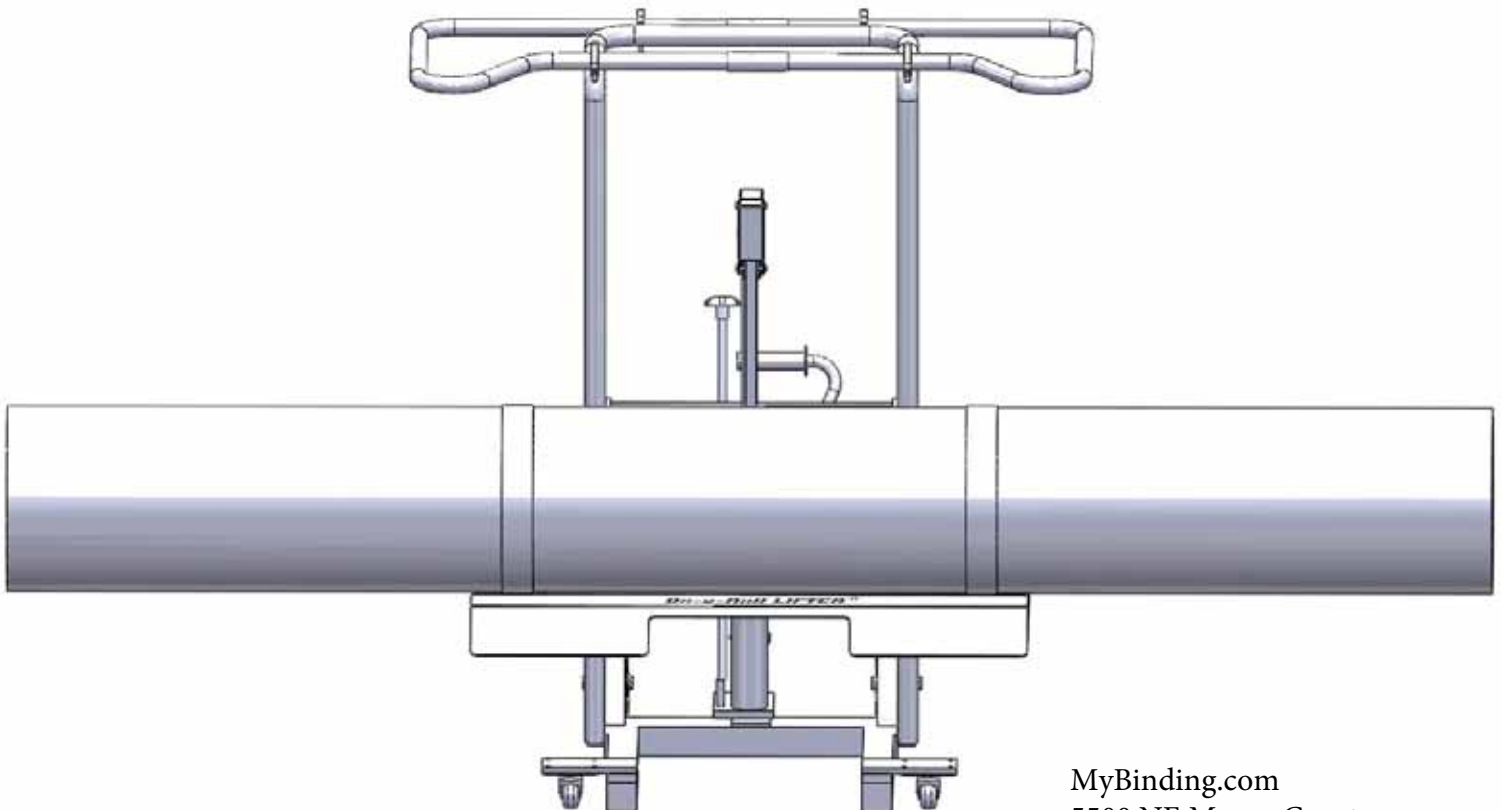

MyBinding.com
5500 NE Moore Court
Hillsboro, OR 97124
Toll Free: 1-800-944-4573
Local: 503-640-5920

Contents

1. Warnings & Safety Rules

- 1.1 Warnings
- 1.2 Caution
- 1.3 Safety Rules

2. Daily Inspection

- 2.1 What to check before operation

3. Installation Guide

- 3.1 Packing list
- 3.2 Placing the Lifter Carriage on the Caster Frame
- 3.3 Installing the Carriage Support Frame
- 3.4 Connecting the chain
- 3.5 Installing the Push Bar
- 3.6 Installing the Lifter Tray

4. Operation

- 4.1 How to use the brakes
- 4.2 Loading the roll onto the tray
- 4.3 Lifting the tray
- 4.4 Lowering the tray
- 4.5 Maneuvering with heavy rolls

5. Maintenance

- 5.1 Lubrication Points

6. Technical Data

- 6.1 Technical Specifications

7. Warranties

Warnings & Safety Rules

1.1 Warnings

1. Do not put your hands or feet under the load tray.
2. All unconcerned personnel should be more than 60 cm away from the unit while the rolls are in transit, or being lifted.
3. Do not move the unit while a load is being raised.
4. Do not move the unit without securing the rolls with the straps.
5. Do not move the unit with tray raised more than a couple inches to avoid tip overs and vision obstruction.
6. Do not operate the lifter if the straps are frayed or damaged.
7. Do not put your foot in front of the swivel wheel; injury could occur when the load is lowered.
8. Do not operate the machine beyond its rated capacities, or outside of the machines' normal operation.
9. Do not operate the media lifter on uneven surfaces.
10. Do not lift persons. People could fall and suffer severe injury.

1.2 Caution

1. Operators should read and understand the instructions before using the On-A-Roll Lifter® to avoid injury.
2. The On-A-Roll Lifter® is used to lift or lower rolls of media (e.g. paper rolls) within specified capacity and should not be used for other functions.
3. Do not operate unless you have been trained or authorized to do so.
4. Do not lower the load at fast speed, as it creates unsafe conditions.
5. Care should be given to the balance and orientation of loads. Unbalanced or shifting loads can cause danger to the operator or bystanders. If the load becomes unstable, stop work immediately.
6. The weight of the roll should be distributed evenly on the load tray. The center of gravity of the goods should be in the center of the load tray width.
7. Do not modify or repair the unit without written consent from the manufacturer.
8. Remove the loaded goods from the lifter and use safety breaks to prevent the lifer from moving when servicing it.
9. This lifter is not designed to be water resistant. If not in use, please store in dry conditions and lower the load tray to the lowest position for stability.

Warnings & Safety Rules

1.3 Safety Rules

Failure to obey the instructions and safety rules in this document may result in serious injury.

1. **Do not operate unless you:**

a) Understand and practice the principles of safe machine operation specified in this manual:

- Avoid hazardous situations
- Always perform a pre-operation inspection
- Always perform the function tests (see step 2.1) prior to use
- Inspect the workplace

b) Read, understand and obey:

- Manufacturer's instructions and safety rules
- Employer's safety rules and worksite regulations
- Applicable governmental regulations

2. **To avoid hazardous situations:**

- Do not overload the lifter
- Make sure media roll is balanced on the Load Tray and steady
- The media roll is secured with two straps
- Do not raise the load unless the machine is on a firm, level surface
- Do not move the lifter with the raised load, except for minor positioning
- Do not tilt the lifter back with raised load
- Do not operate the lifter in strong and gusty winds
- Prior to use, inspect the work area for drop-offs, holes, bumps, debris, unstable surfaces or other possible hazardous conditions
- Do not subject the lifter to horizontal force by raising or lowering a fixed or overhanging load
- The lifter can only be used in a lighted environment at least 50LUX

3. **Collision Hazards:**

- Do not lift the load if not properly centered on the Load Tray
- Check the work area for overhead obstruction or other possible hazards
- Do not stand under or allow personnel under the lifter when the load is raised
- Do not lower the load unless the area below is clear of personnel and obstructions

Warnings & Safety Rules

1.3 Safety Rules

4. **Bodily Injury Hazards:**
 - Keep hands and fingers away from chain, wheels and other potential pinch points
 - Recommend operators wear safety shoes and gloves
 - Do not put your feet under the load tray

5. **Improper Use Hazard:**
 - Never leave a machine unattended with the load. Unauthorized personnel may attempt to operate the machine without proper instruction, creating an unsafe situation.

6. **Damaged Machine Hazards:**
 - Do not use a damaged or malfunctioning machine
 - Be sure all the decals are in place and visible
 - Maintain proper lubrication of the chain

7. **Other Items:**
 - When turning and pushing the machine on rough flooring, more effort will be required
 - Keep rolls centered to avoid them tipping to the side
 - When working on sloped surfaces, secure straps around media to avoid movement of rolls toward the rear of the lifter

Failure to obey the instructions and safety rules in this document may result in serious injury.

Daily Inspection

2.1 What to check before operation

It is the operator's responsibility to make sure that the On-A-Roll Lifter® is inspected daily to ensure safe operation:

Check the On-A-Roll Lifter® before operation:

1. Inspect the vertical guide rails, load tray, carriage and hydraulic components for damage, including bending, cracking and loose or missing hardware. Do not use the On-A-Roll Lifter® if any faults are discovered during your visual inspection.
2. Inspect the hydraulic system and nearby surfaces for evidence of leaks. Discontinue use if leaking is evident.
3. Inspect the (4) caster wheels for damage and smooth operation. Wheels should rotate and swivel smoothly, and should not be cracked, chipped or broken. Do not use if wheels are damaged or broken.
4. Check the function of the brake. Ensure the parking brakes on the rear casters are working properly.
5. Ensure all hardware is present and fitted correctly. Inspect/tighten any loose fasteners or hardware.

Caution: Do not use the unit if any malfunction or fault is found.

Installation Guide

3.1 Packing List

Unpacking your machine:

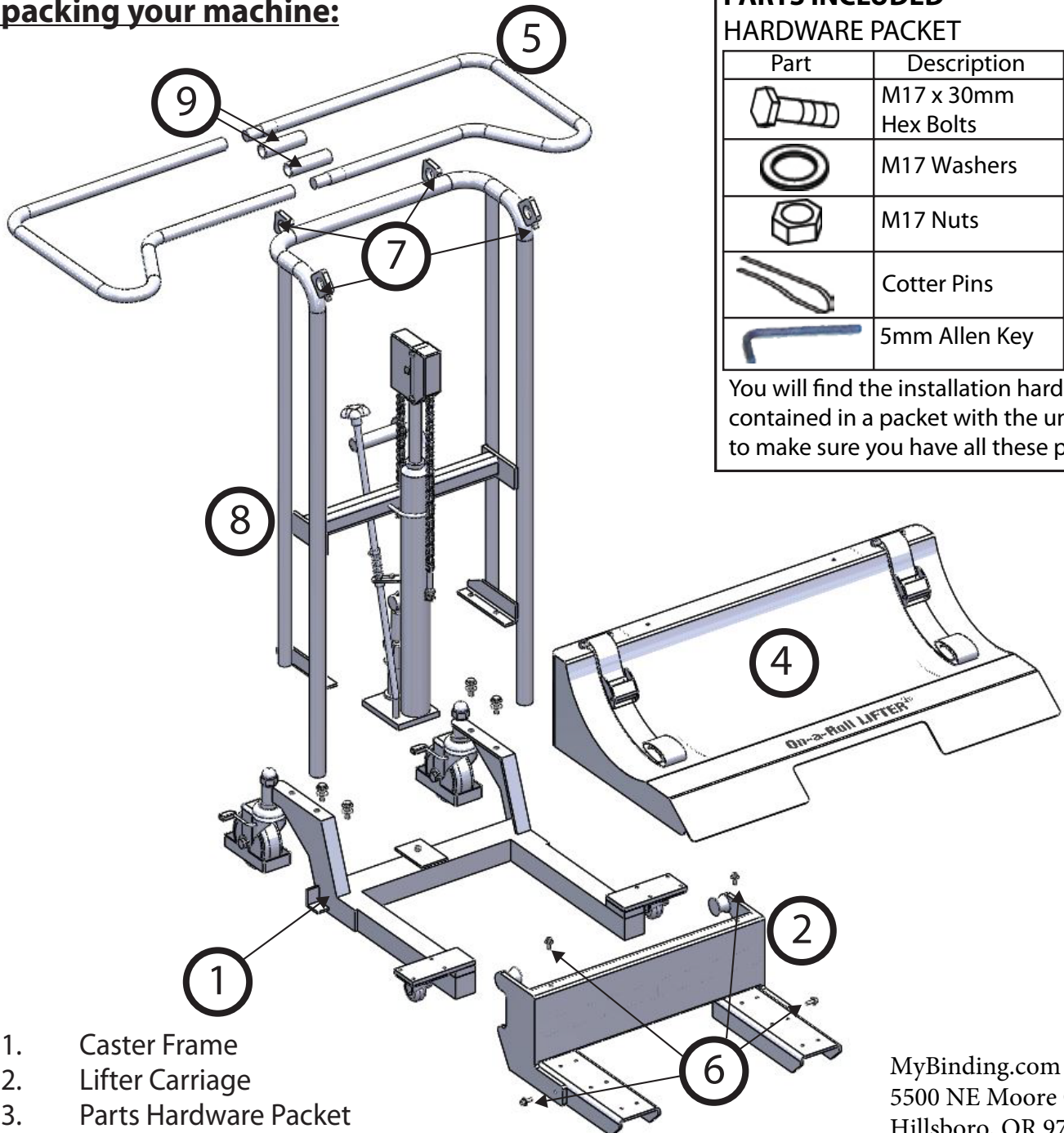

PARTS INCLUDED		3
HARDWARE PACKET		
Part	Description	Quantity
	M17 x 30mm Hex Bolts	4
	M17 Washers	8
	M17 Nuts	4
	Cotter Pins	2
	5mm Allen Key	1

You will find the installation hardware contained in a packet with the unit. Check to make sure you have all these parts.

1. Caster Frame
2. Lifter Carriage
3. Parts Hardware Packet
4. Media Tray
5. Ergonomic Pull Bar
6. 4 M6 x 12mm Bolts & 4 Washers installed on Lifter Carriage
7. 4 M6 x 19mm Bolts installed on Carriage Support Frame
8. Carriage Support frame
9. Rubber Sleeves

You will need: 17mm wrenches

MyBinding.com
 5500 NE Moore Court
 Hillsboro, OR 97124
 Toll Free: 1-800-944-4573
 Local: 503-640-5920

Installation Guide

3.2 Placing the Lifter Carriage on the Caster Frame

1. With the Caster Frame Assembly on the ground, place the Lifter Carriage on top of it so that the forks rest flat on the base.

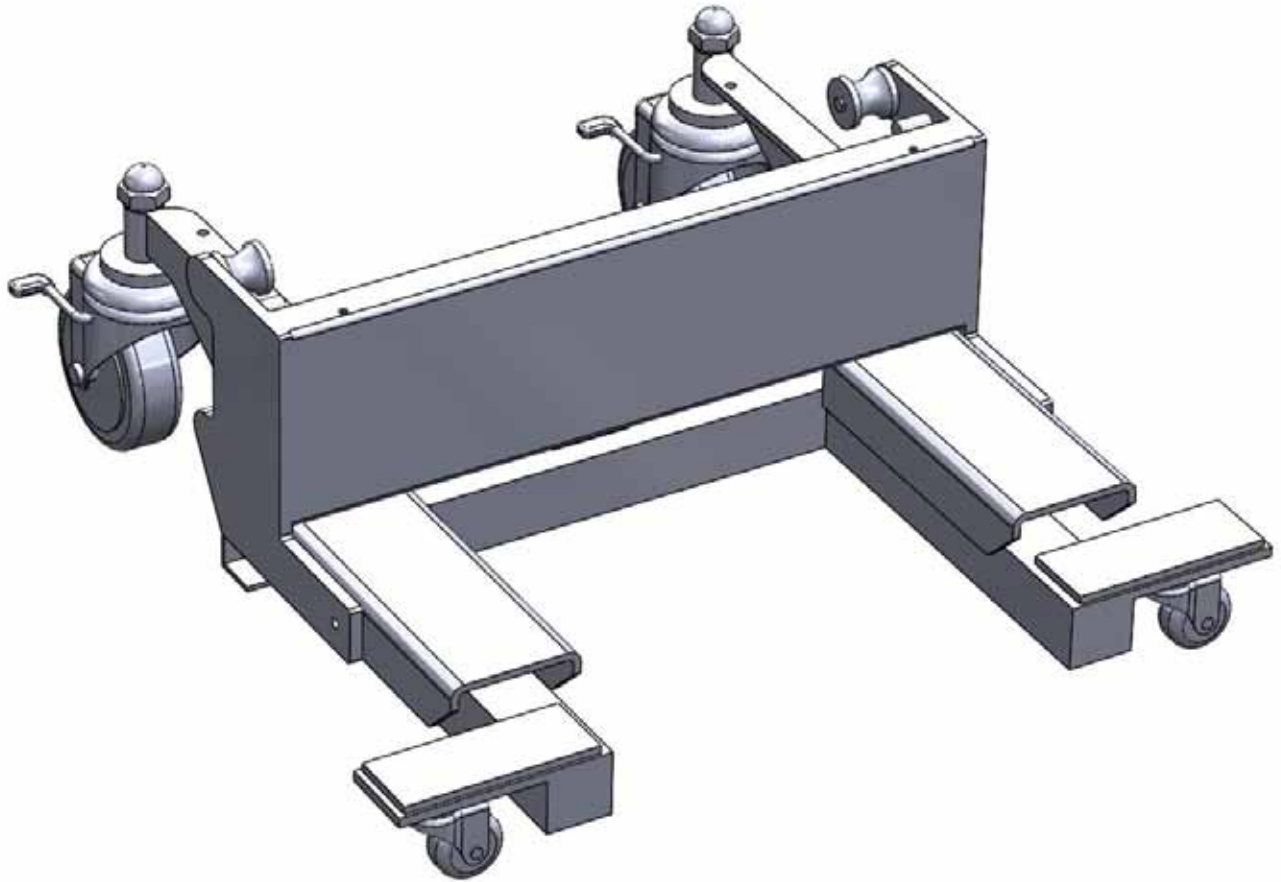

MyBinding.com
5500 NE Moore Court
Hillsboro, OR 97124
Toll Free: 1-800-944-4573
Local: 503-640-5920

Installation Guide

3.3 Installing the Carriage Support Frame

1. Pick up the carriage support frame and guide the support frame's front tubes between the guide bearings and the lifter carriage frame so that they rest on the caster frame's support bracket.
2. On the carriage support frame, line the tube support bracket holes with the holes on top of the caster frame.

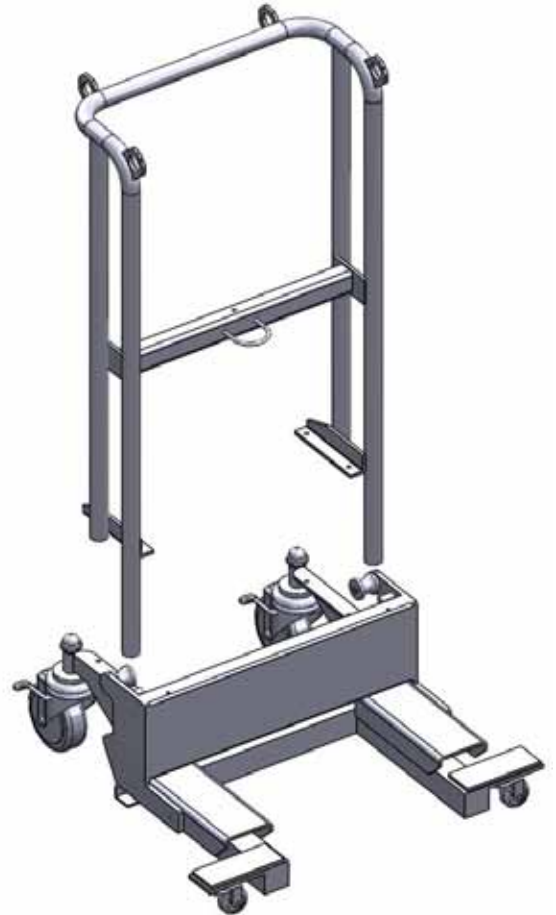

3. On the bottom of the hydraulic cylinder, line up the hole so that it rests on top of the boss on the caster frame.

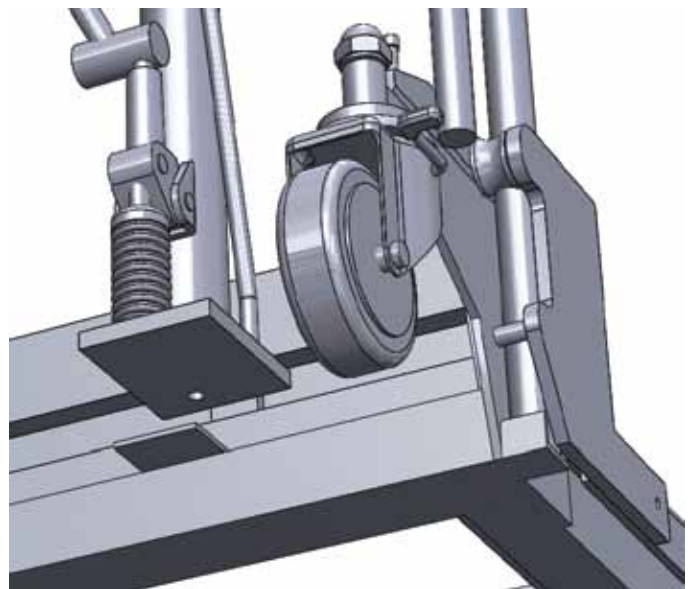
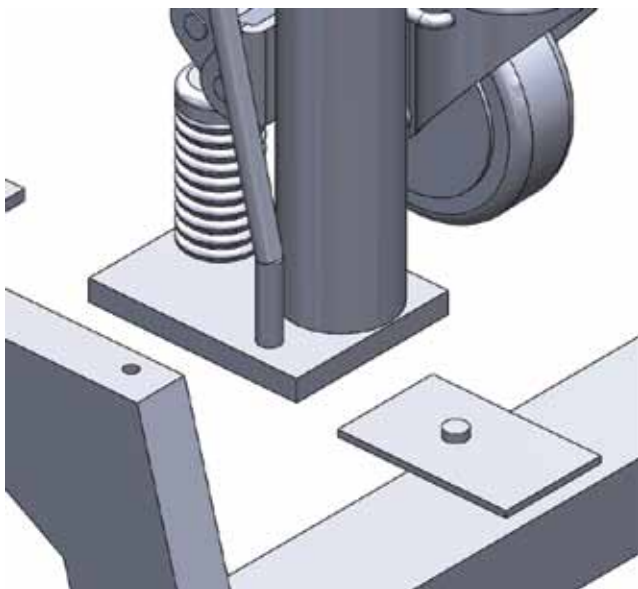

Installation Guide

3.3 Installing the Carriage Support Frame

4. Using two 17mm wrenches or adjustable wrenches, connect the support and caster frame. Place a washer on the carriage bolt and slide it through one of the aligned holes to connect the carriage support frame to the caster frame. Then place a washer and nut on the bolt and tighten. Repeat with the remaining 3 bolt sets.

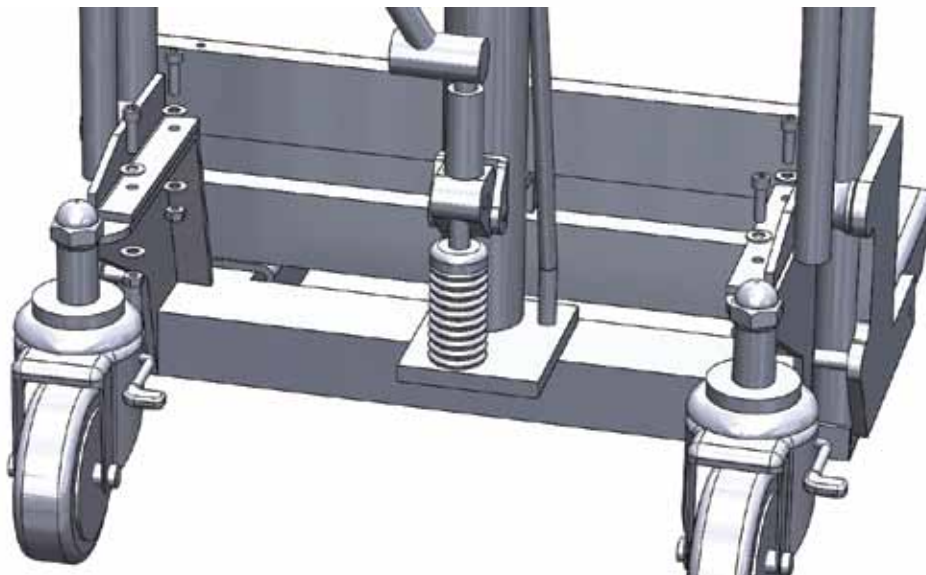
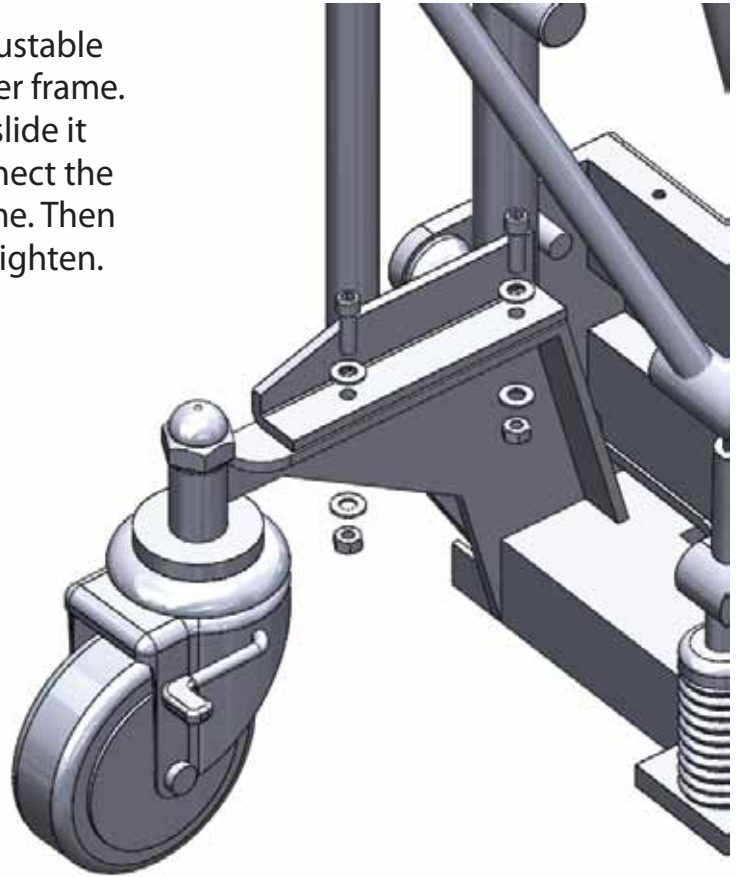

Installation Guide

3.4 Connecting the chain

1. Remove the 2 nuts on each side of the chain with a 17mm wrench.

2. Starting with the back side, slide the threaded end of the chain through the two holes in the back of the lifter frame and insert the 2 nuts onto the threaded end. Tighten with the wrench.

3. Insert the cotter pin into the end of the threaded bolt and bend prongs outward to secure.

4. Next, attaching the front side. Check to make sure the hydraulic pump is all the way down by turning the release valve and pushing down on the hydraulic pump chain guard.

5. Slide the threaded end of the chain through the hole on the back of the lifter carriage and insert the 2 nuts onto the threaded end. Tighten with the wrench.

6. Insert the cotter pin into the end of the threaded bolt and bend prongs outward to secure.

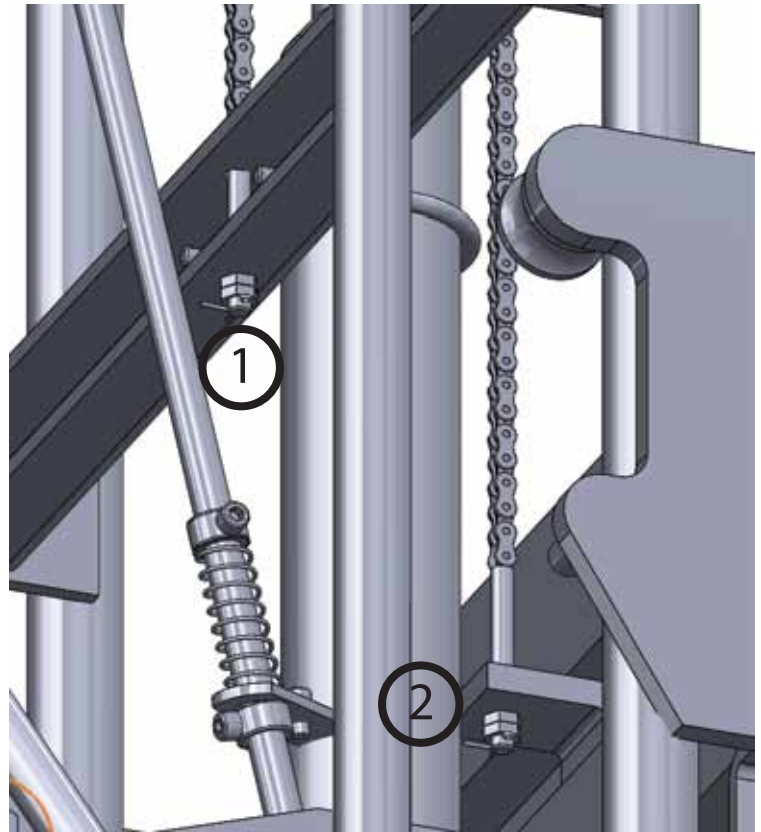

Installation Guide

3.5 Installing the Ergonomic Pull Bar

1. Using the 5mm Allen Key, loosen the 4 bolts enough to allow the push bar entry through the openings.
2. Insert both sides of the push bar with the straight ends towards the back and the curved ends facing the front of the lifter.
3. Slide a rubber sleeve onto both sides on one end.
4. Connect the two sides in the center with one side overlapping the second side so that they fit together and centered.
5. Tighten the 4 bolts.
6. Slide each rubber sleeve over the gap.

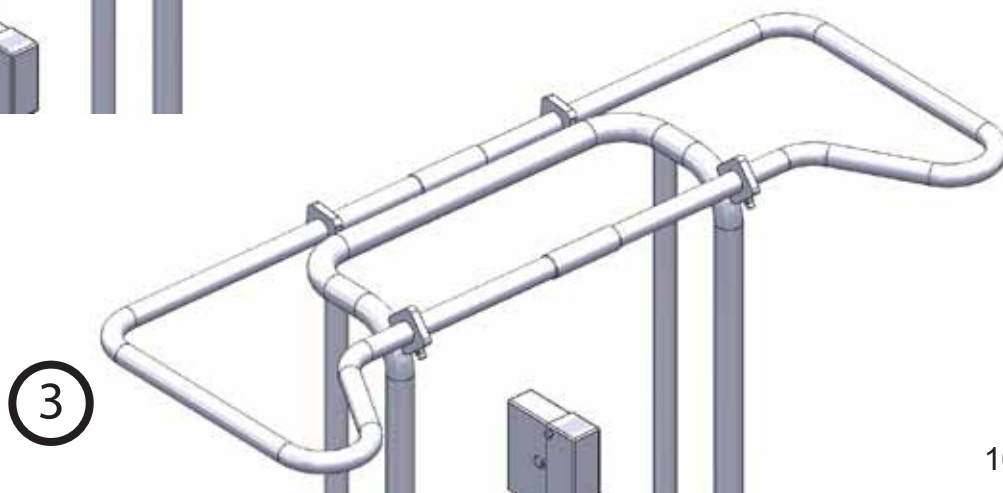
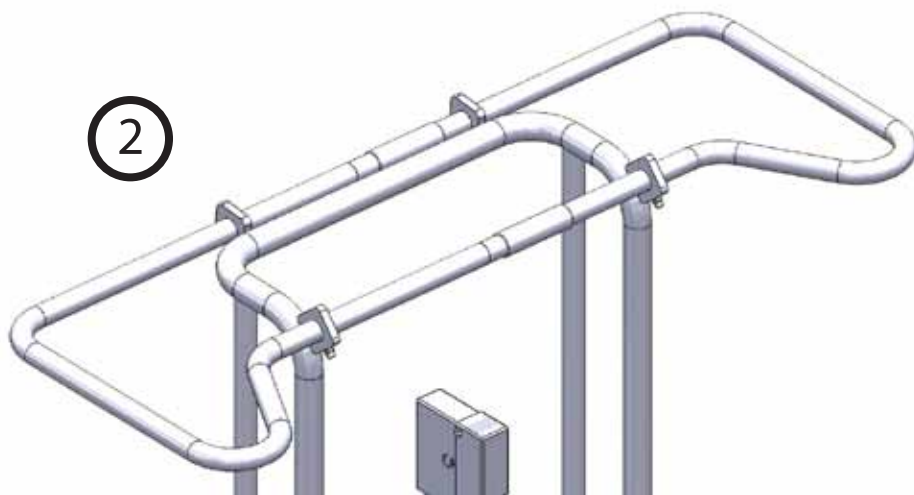
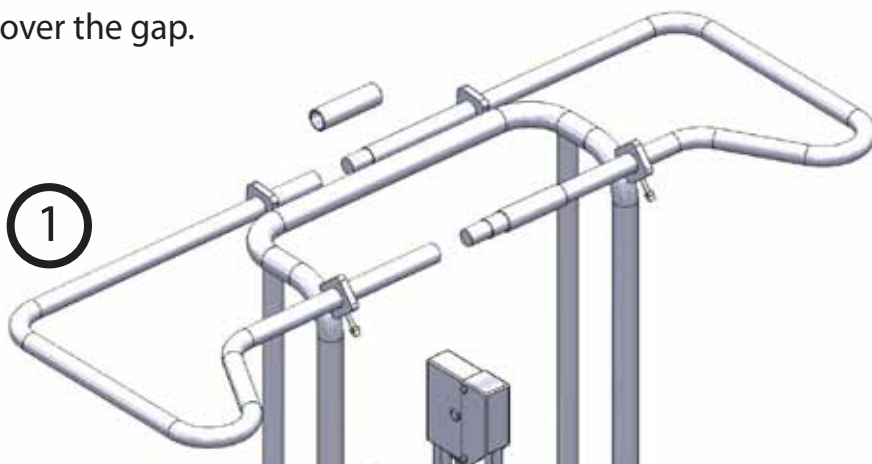

Installation Guide

3.6 Installing the Lifter Tray

1. Remove the 4 screws and washers from the tray base on the main body. There will be 2 screws on top and 1 screw on each side of the Lifter.
2. Place the tray on the lifter carriage.
3. Tighten all 4 screws, attaching the Lifter Tray to the On-A-Roll Lifter®.

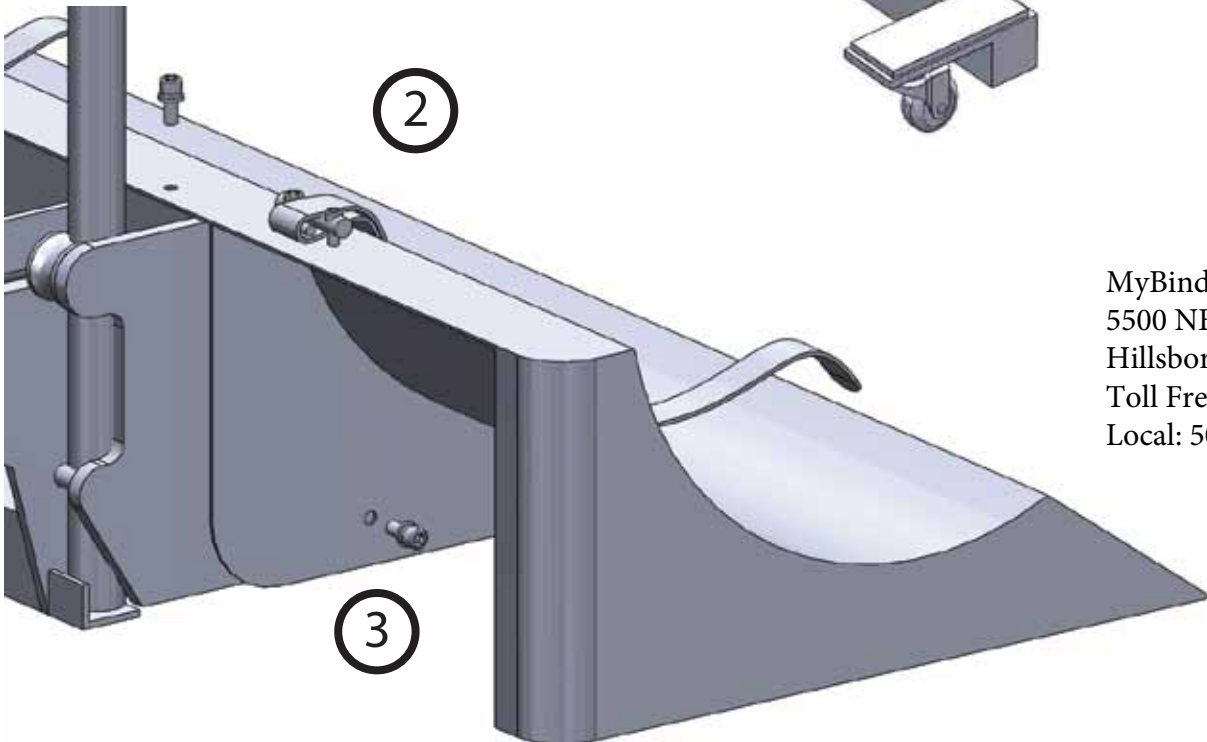
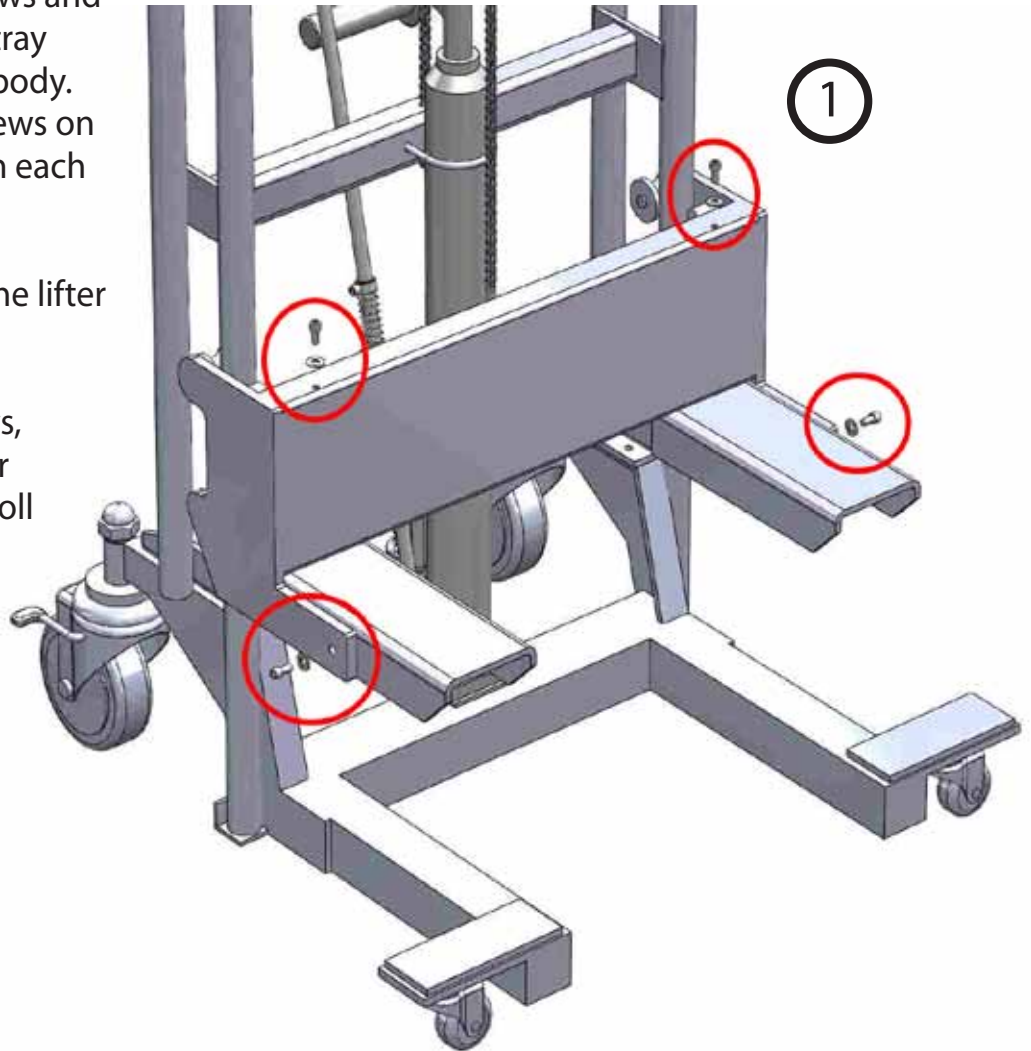

MyBinding.com
5500 NE Moore Court
Hillsboro, OR 97124
Toll Free: 1-800-944-4573
Local: 503-640-5920

Operation

4.1 How to use the brakes

The Lifter is equipped with 2 brakes.

1. To engage the brake, press both the brake pedals with your foot.
2. To release the brake, lift up the brake pedals with your foot.

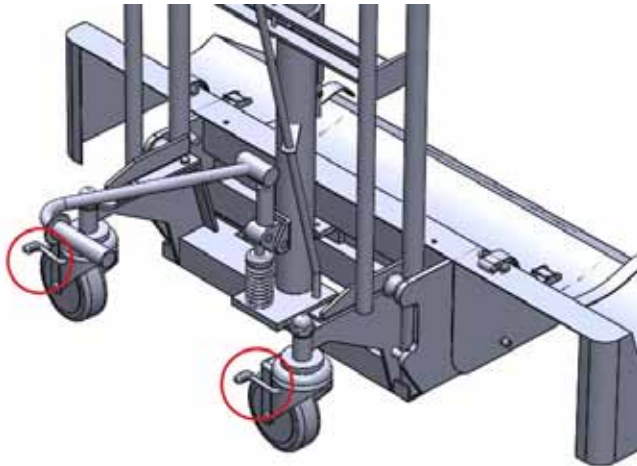

Locks shown on the
Caster Wheels in the
unlock position.

4.2 Loading the roll onto the tray

1. Ensure the load tray is at its lowest position.
2. Make sure the brakes are applied.
3. Lay out the securing straps across the load tray, and extended onto the floor.
4. Position the media over the straps, and up to the edge of the load tray.
5. Move towards the back of the On-A-Roll Lifter®.
6. Take the ends of the straps and pull them towards you until the roll media falls in place on the load tray. Make sure the media is properly centered in the media tray.
7. Secure the straps.

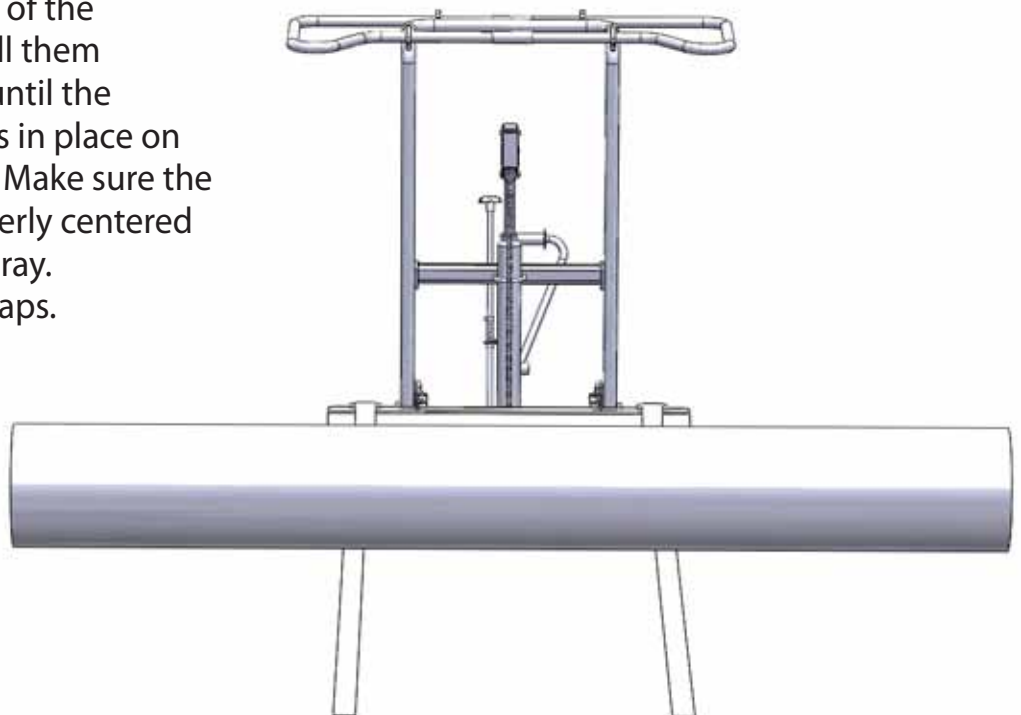

Operation

4.3 Lifting the tray

Warning: Do not overload the load tray. The load must be evenly distributed on the Load Tray surface so that it does not tilt forward or sideways. The parking brakes should be engaged whenever the On-A-Roll Lifter® is being loaded or unloaded.

1. To raise the load tray, pump the lift pedal with your foot.
2. Press the lifting pedal several times until the load tray reaches the desired position. The load tray can be raised up to 0.85m (33in) for precise unloading.

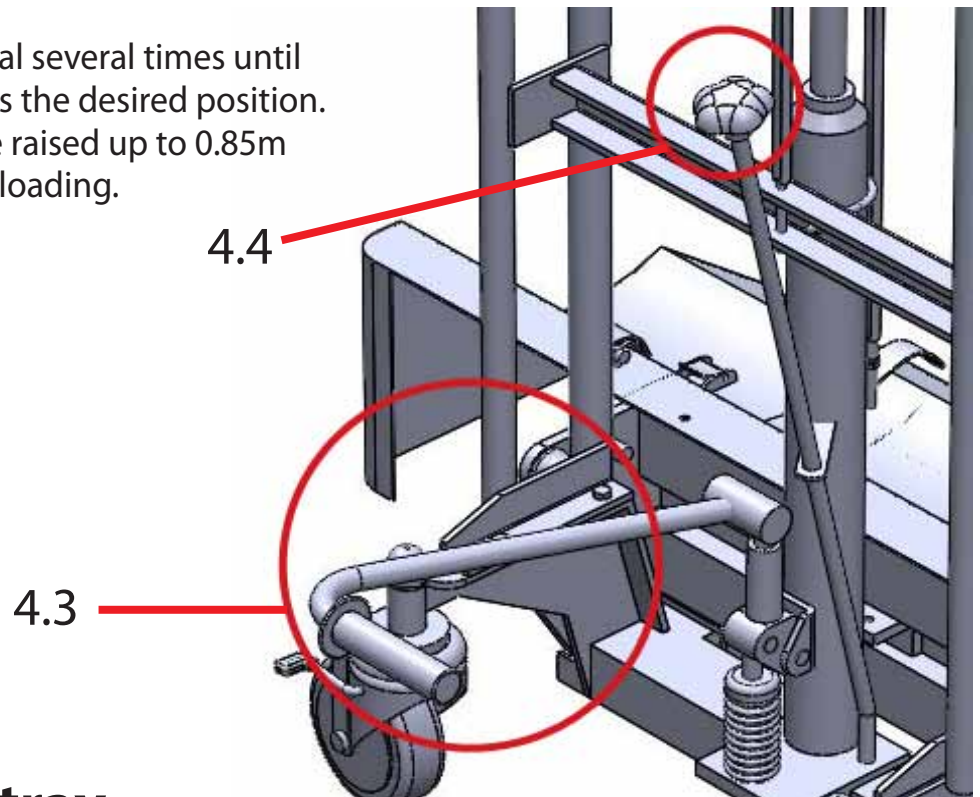

4.4 Lowering the tray

Warning: do not put any part of the body under the Load Tray. The parking brakes should be engaged whenever the On-A-Roll Lifter® is being loaded or unloaded.

1. To lower the load tray, turn the release valve knob counterclockwise slowly.
2. Do not open the release valve too quickly, as this creates a dangerous work environment.

4.5 Maneuvering with heavy rolls

1. To adjust the direction of the wheels and ensure smooth rolling action on heavy loads, exert force on the curved handle and simultaneously lift the unit with the Push Bar.

Maintenance

5.1 Lubrication Points

1. Lubricate with grease each point described below each month:
 - a) Axle and bearing wheels
 - b) Chain guide roller on cylinder
 - c) Connecting chain assembly
 - d) Injection fittings located on the Lift Pump handle assembly

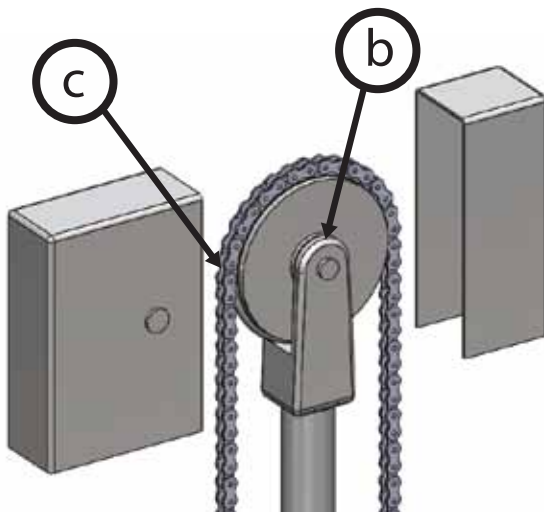
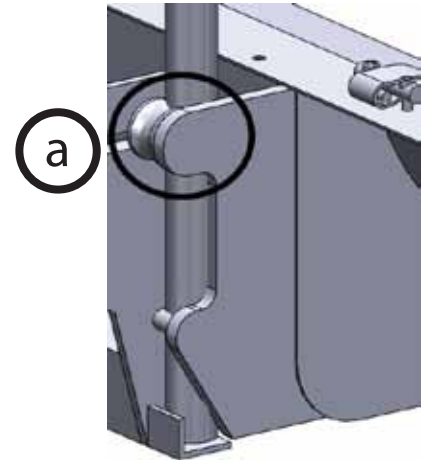

Remove screw to access the chain guide.

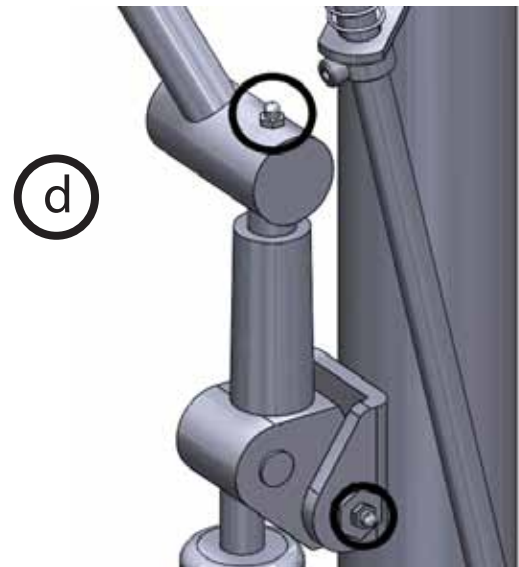

2. Change hydraulic oil every 12 months.

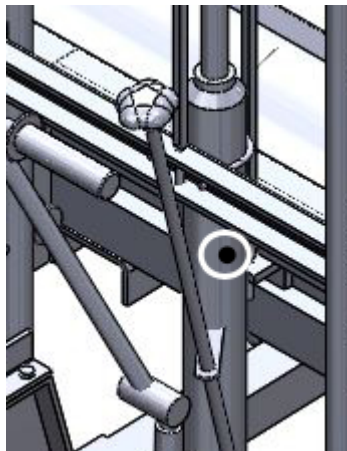

MyBinding.com
5500 NE Moore Court
Hillsboro, OR 97124
Toll Free: 1-800-944-4573
Local: 503-640-5920

Technical Data

6.1 Technical specifications

Specifications	LIFTER ITEM # 61574
Roll Weight Capacity	660 lbs (300 Kg)
Max. Roll Width	16' .4" (5 m)
Max. Roll Diameter	15.75" (40cm)
Oil	Use L-HM46 Hydraulic oil (equivalent to ISO VG46)

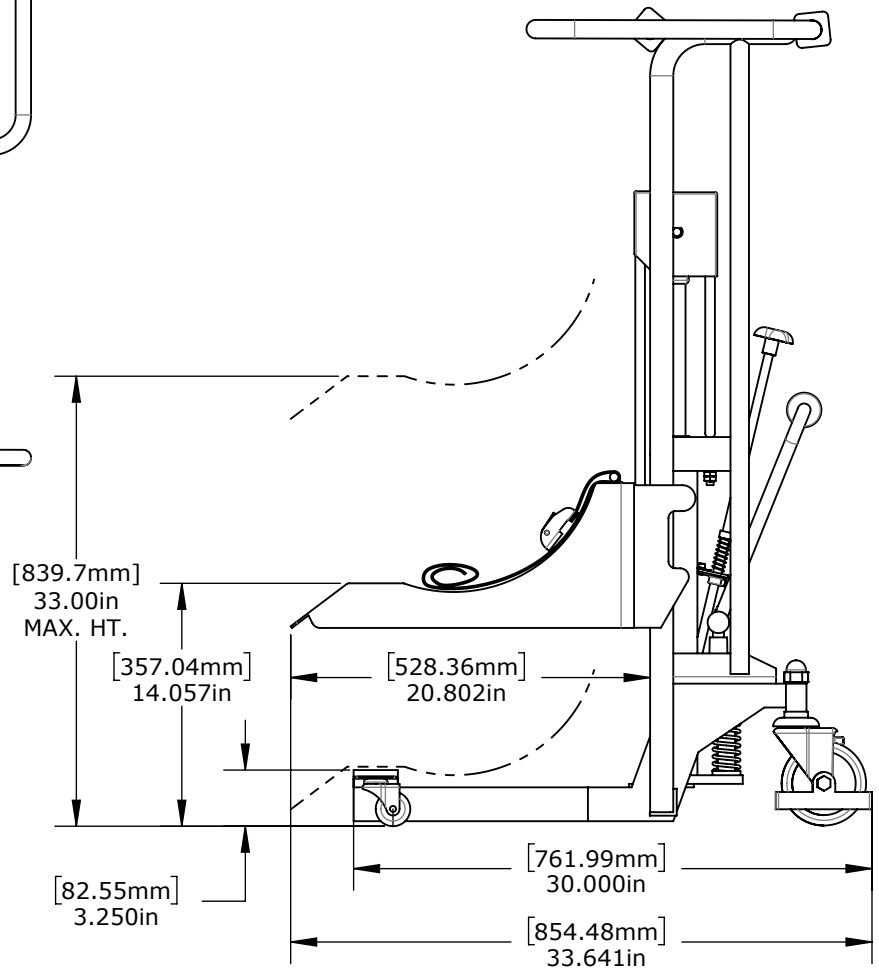
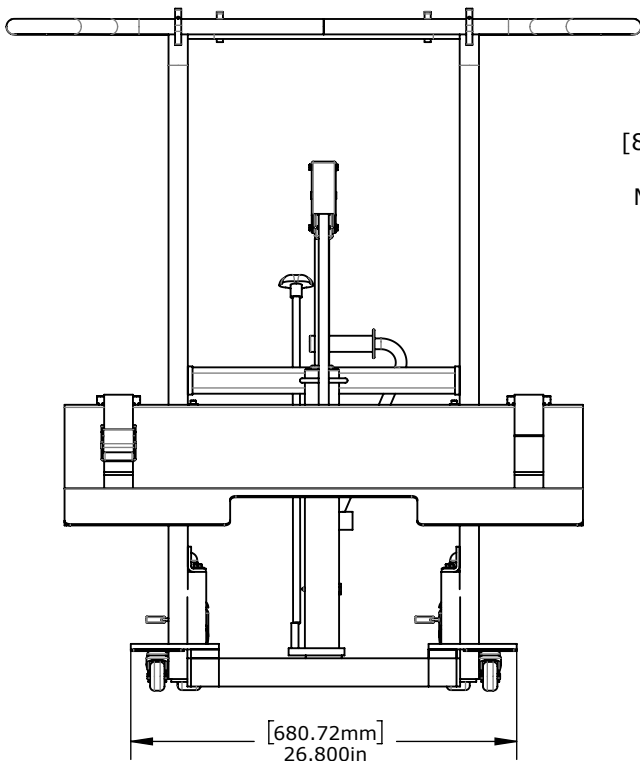
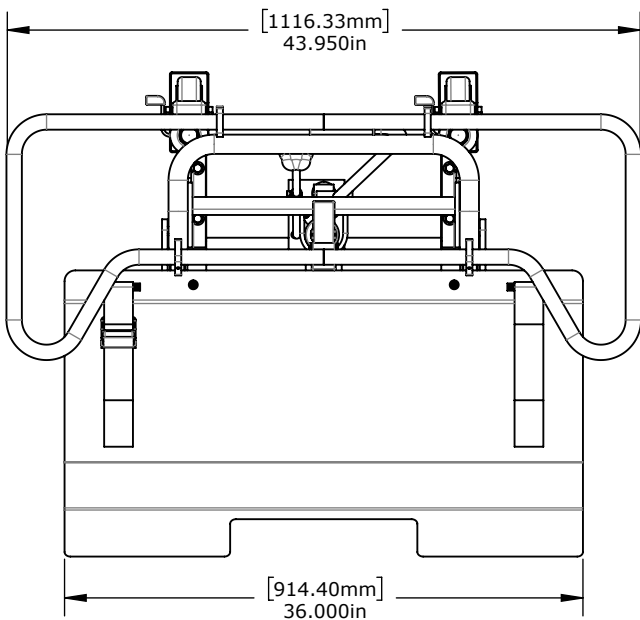

Warranties

7 Warranties

1. 2- year warranty on all wheels, hydraulics and media tray
2. 5-year warranty on the crossbar

All Foster products are inspected before shipment and believed to be free from defects in workmanship. Foster cannot be responsible for tools that show excessive wear or damage resulting from misuse, accidents or abuse.

These warranties do not cover any product that has been altered, modified or damaged, neglected, accidentally dropped or improperly used. If any of the previous occurs, the warranty shall be considered null and void.