

***Ghent 4' x 4' Mahogany
Conference Cabinet - Magnetic
Porcelain Whiteboard w/ Cork
Interior Doors***

Instruction Manual



Provided by

MyBinding.com
When Image Matters.

Call Us at 1-800-944-4573

TAPED TO THE BACK OF YOUR CONFERENCE CABINET IS A WALL BRACKET FOR HANGING THE UNIT. THERE IS A MATCHING BRACKET ALREADY ATTACHED TO THE BACK OF THE UNIT. YOU WILL NEED A PENCIL, LEVEL, DRILL, AND SCREW DRIVER ON HAND BEFORE PROCEEDING.

YOUR CONFERENCE CABINET IS DESIGNED FOR MOUNTING ON MOST WALL SURFACES. BECAUSE OF THE WIDE VARIATION OF MOUNTING SURFACE CONSTRUCTION, SPECIFIC MOUNTING HARDWARE IS NOT INCLUDED.

FOR THE MOST SECURE MOUNTING, FASTEN THE WALL BRACKET DIRECTLY TO WALL STUDS USING #8 SCREWS (NOT INCLUDED). WHEN WALL STUDS CAN NOT BE USED, WE RECOMMEND USING #8 EXPANDABLE TYPE WALL ANCHORS (NOT INCLUDED)

1. REMOVE THE WALL BRACKET AND HARDWARE PACKAGE FROM THE CABINET. THE HARDWARE PACKAGE SHOULD CONTAIN (2) DOOR PULLS, (4) 1-1/2" SCREWS (FOR THE DOOR PULLS), (4) ADJUSTING PADS, (1) BOX OF DRY ERASE MARKERS AND (1) ERASER.
2. DETERMINE THE CABINET MOUNTING HEIGHT. AS A REFERENCE: THE BOTTOM OF THE CABINET WILL HANG APPROXIMATELY 45 1/2" BELOW THE BOTTOM OF THE WALL BRACKET.

TO MOUNT THE CONFERENCE CABINET USING #8 SCREWS INTO STUDS.-

3a. LOCATE AT LEAST TWO STUDS IN THE WALL AND MARK THE LOCATION OF THE STUDS AT THE APPROXIMATE HEIGHT THE BRACKET IS TO BE HUNG. SCRIBE A LEVEL LINE BETWEEN THE TWO MARKED LOCATIONS. PLACE THE NARROW SIDE OF THE BRACKET AGAINST THE WALL AT THE CHOSEN HEIGHT. WITH THE BEVELED EDGE UP (SEE FIG. 1), ADJUST THE BRACKET UNTIL THE HOLES IN THE BRACKET ALIGN WITH THE SCRIBED LINE AND STUD LOCATIONS ON THE WALL. USING THE WALL BRACKET AS A TEMPLATE, MARK THE HOLE LOCATIONS ON THE WALL. REMOVE THE WALL BRACKET AND DRILL 3/32" DIAMETER HOLES AT THE MOUNTING HOLE LOCATIONS. MOUNT THE WALL BRACKET USING THE #8 SCREWS (NOT INCLUDED). CHECK TO BE SURE THAT SCREWS AND BRACKET ARE SECURELY FASTENED TO WALL. HOOK THE UNIT BRACKET OVER THE WALL BRACKET.

TO MOUNT THE CONFERENCE CABINET USING EXPANDABLE WALL ANCHORS...

3b. ON THE WALL, SCRIBE A LEVEL LINE AT THE APPROXIMATE HEIGHT THE BRACKET IS TO BE HUNG. PLACE THE NARROW SIDE OF THE BRACKET AGAINST THE WALL AT THE CHOSEN HEIGHT. WITH THE BEVELED EDGE UP (SEE FIG. 1), ADJUST THE BRACKET UNTIL THE HOLES IN THE BRACKET ALIGN WITH THE SCRIBED LINE ON THE WALL. USING THE WALL BRACKET AS A TEMPLATE, MARK THE HOLE LOCATIONS ON THE WALL. REMOVE THE WALL BRACKET AND DRILL THE ANCHOR MOUNTING HOLES PER THE ANCHOR MANUFACTURES INSTRUCTIONS. INSTALL THE #8 ANCHORS (NOT INCLUDED) INTO THE HOLES PER THE ANCHOR MANUFACTURES INSTRUCTIONS. MOUNT THE WALL BRACKET USING THE ANCHOR SCREWS. CHECK TO BE SURE THAT SCREWS AND BRACKET ARE SECURELY FASTENED TO WALL. HOOK THE UNIT BRACKET OVER THE WALL BRACKET.

4. ATTACH THE DOOR PULLS BY INSERTING THE FOUR SCREWS (PROVIDED) INTO THE HOLES ON THE INSIDE OF THE DOORS. POSITION THE PULLS OVER THE SCREW TIPS COMING THROUGH THE FRONT OF THE DOORS. USING A SCREWDRIVER, SCREW BOTH SCREWS IN EACH DOOR PULL AND TIGHTEN SECURELY.

5. IF THE WALL IS NOT FLAT, THE DOORS MAY NOT LAY FLAT AGAINST THE FRAME. TO ALIGN THE DOORS PLACE ONE OR MORE OF THE ADJUSTMENT PADS (WITH ITS BACKING STILL ATTACHED) BEHIND ONE OF THE BOTTOM CORNERS OF THE CABINET UNTIL THE DOORS LIE FLAT. REMOVE THE UNIT FROM WALL, PEEL THE BACKING OFF THE PADS AND STICK IN PLACE TO THE BACK OF UNIT.

MOUNTING HARDWARE (NOT INCLUDED)

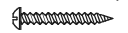
HOLLOW WALL ANCHORS #8 X 2 1/2" SCREWS #8 X 2 1/2"
(AS NEEDED)

MAY BE ACQUIRED FROM LOCAL SOURCES

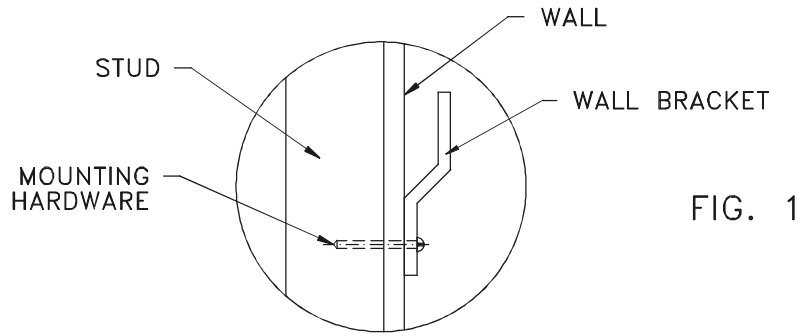

FIG. 1

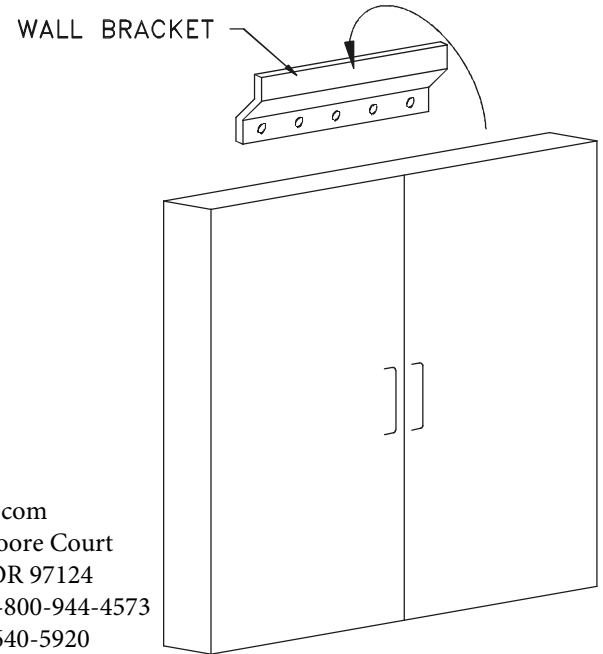

FIG. 2

MyBinding.com
 5500 NE Moore Court
 Hillsboro, OR 97124
 Toll Free: 1-800-944-4573
 Local: 503-640-5920

**CONFERENCE CABINET
 INSTRUCTION SHEET**

ISC448510G