

# ***HSM FA400.2 Strip Cut Conveyor Belt Shredder***

Instruction Manual



*Provided by*

**MyBinding.com**

*When Image Matters.*

Call Us at 1-800-944-4573

**FA 400.2**

**OPERATING MANUAL  
SHREDDER**



**HSM**<sup>®</sup>  
*Powerline FA 400.2*

**Contents**

1 Proper use, warranty.....3

2 Safety instructions.....3

3 Overview .....4

4 Dimensions .....5

5 Transportation, installation .....6

6 Operating and display elements .....7

7 Start-up .....7

8 Malfunctions.....9

9 Maintenance and care .....10

10 Disposal / Recycling.....11

11 Scope of supply, accessories.....11

12 Technical data .....12

**HSM (UK) Ltd.**

14 Attwood Road / Zone 1  
 Burntwood Business Park  
 Burntwood  
 Staffordshire  
 WS7 3GJ

Tel. +44(0) 1543.272.480  
 Fax +44(0) 1543.272.080  
 info@hsmuk.co.uk  
 www.hsmuk.co.uk



**HSM GmbH + Co. KG**

AustraÙe 1-9  
 88699 Frickingen / Germany

Tel. +49 7554 2100-0  
 Fax. +49 7554 2100 160  
 info@hsm.eu  
 www.hsm.eu

**HSM of America LLC**

419 Boot Road  
 Downingtown, PA 19335

Tel. (484) 237-2308  
 (800) 613-2110  
 Fax (484) 237--2309  
 customerservice@hsmofamerica.com  
 info@hsmofamerica.com  
 www.hsmofamerica.com

## 1 Proper use, warranty

The shredder is exclusively designed for destroying paper and cardboard, as well as store cards, credit cards, CD-ROMs and floppy disks. Its sturdy drive mechanism is not damaged by paper clips and staples.

Our general business conditions are applicable. We provide a one year warranty for the document shredder. The warranty period is 6 months when used in multiple shifts. This warranty excludes wear, damage due to improper handling, natural depreciation, and actions taken by third parties.



### **Danger of injury**

Do not reach into the paper feed opening.



### **Splinters can cause injury**

Before destroying credit cards and store cards, CD-ROMs or floppy disks, you must fit a splinter guard (strip curtain, order no. 1.513.050.445).



### **Danger of injury during intake**

Do not go near the paper feed opening with long hair, loose clothing, ties, scarves, necklaces, bracelets etc.

Do not destroy any material which might become tangled, such as tapes, binder ties or foil.



The shredder may not be operated by anyone under 16 years of age. Do not leave the document shredder switched on when it is unattended.

## 2 Safety instructions



### **Danger:**

It is prohibited to operate one only machine of a combination-version machine.

The safety clearances are only guaranteed with the combined document shredder and HSM press.



Before using the machine for the first time, read the operating manual, and keep it for later use and to pass on to any subsequent users. Observe all safety instructions on to the machine.

- Ensure that no unauthorised persons can access the document shredder. When the machine is not in use, it must be shut down and secured against unauthorised use. To do so, you can secure the mains switch with a padlock when it is in the off position.
- Do not remove or modify safety devices which guarantee the safe operation of the machine. No platforms or other raised surfaces may be placed near the shredder if they encroach on the specified safety clearances.
- Make sure that the power plug is easily accessible.
- Carry out inspection and maintenance regularly.
- Switch off the shredder, disconnect the power plug and call customer service in the following circumstances:
  - Power cables or plugs are damaged
  - Liquid has entered the shredder
  - The shredder has been exposed to rain
  - The machine does not work properly despite the operating manual having been observed
  - The shredder has been damaged

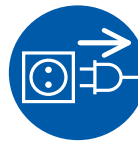

Switch off the shredder and pull out the power plug before moving or cleaning the shredder, or any other task outside its normal scope of use.



Maintenance and service tasks may only be performed by HSM customer service and service engineers of our dealers.

## Operating controls for your safety

### Emergency stop button

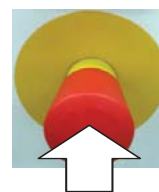

In the event of danger, press the emergency stop button immediately. This switches off the shredder, and stops the cutting block and feed belt.

### Main switch (only Solo-version)



In the event of danger, turn the main switch to "0". You can secure the main switch in this position with a padlock to prevent restarting.

3 Overview

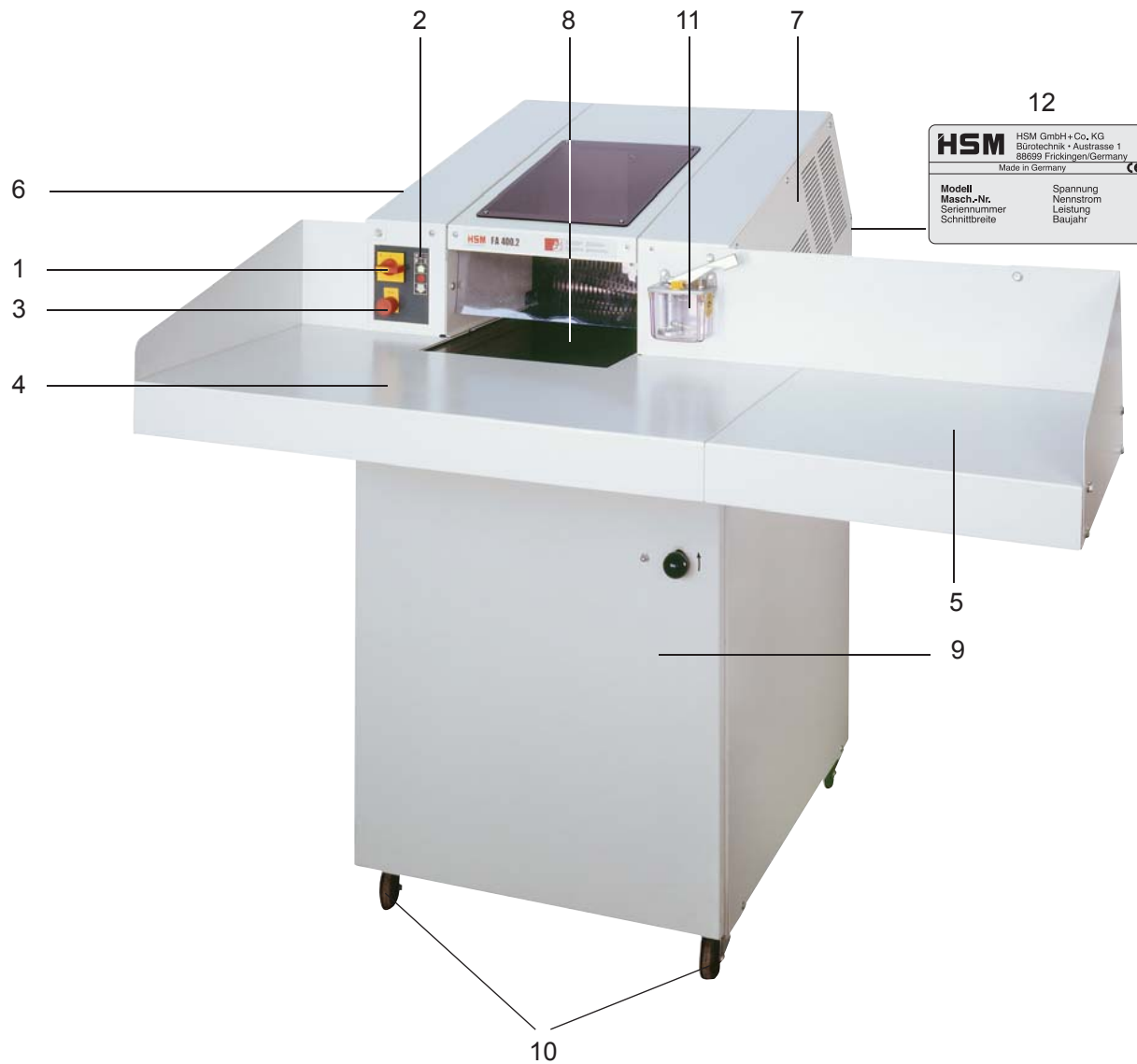

<b>HSM</b>		HSM GmbH+Co., KG Bürotechnik • Austraße 1 88699 Frickingen/Germany		CE
Made in Germany				
Modell		Spannung		
Masch.-Nr.		Nennstrom		
Seriennummer		Leistung		
Schnittbreite		Baujahr		

- 1 Main switch (only solo-version)
- 2 Keypad
- 3 Emergency stop button
- 4 Loading tray
- 5 Option: extra-wide work table
- 6 Left cover panel
- 7 Right cover panel
- 8 Intake conveyor,  
paper feed opening
- 9 Front door
- 10 Braking swivel castors
- 11 Oiler on particle cut machines
- 12 Nameplate

**4 Dimensions**

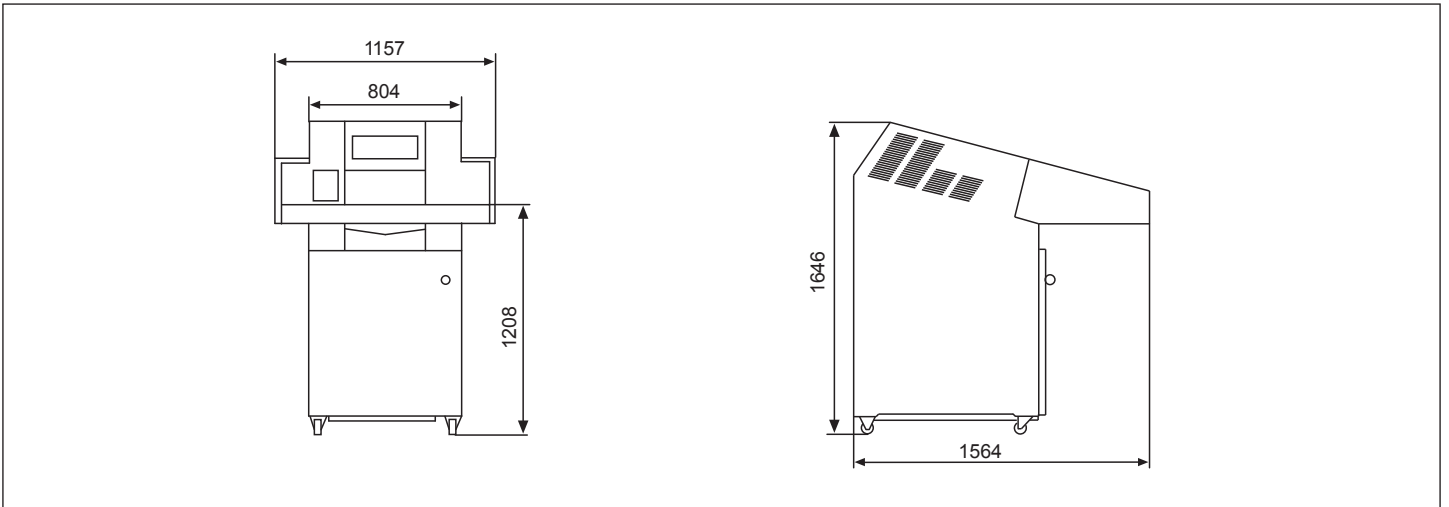

**HSM FA 400.2 Solo version**

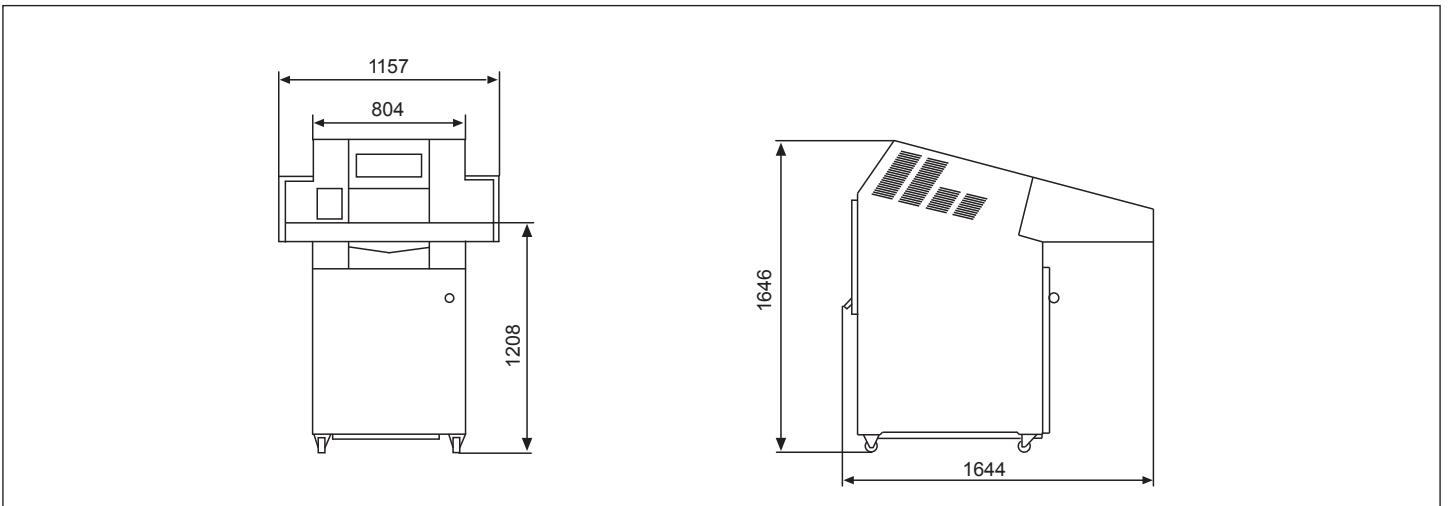

**HSM FA 400.2 Combi version**

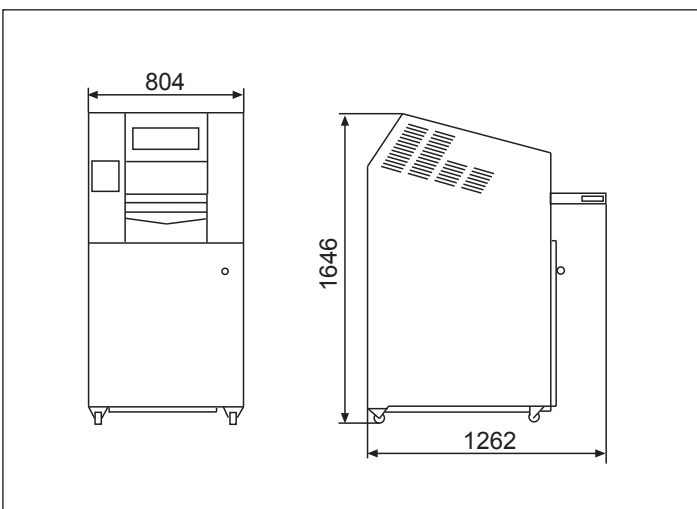

**Transportation dimensions (without tray)**

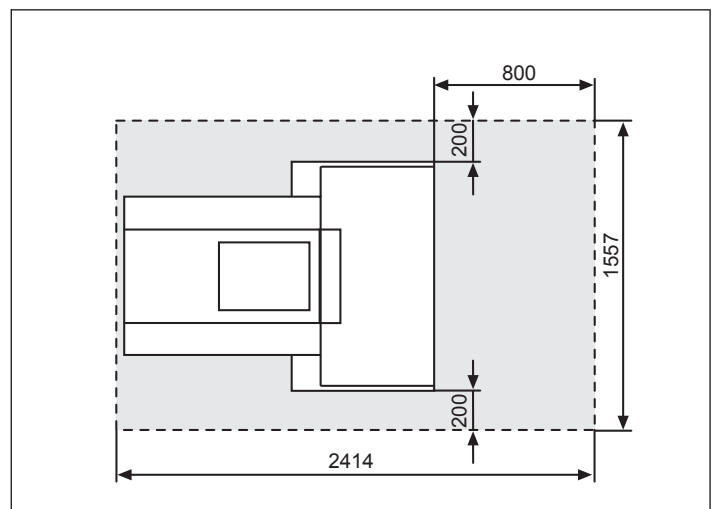

**Space requirements for operation and maintenance**

## 5 Transportation, installation

- The transport device (e.g. hand pallet truck) must be correspondingly rated for the weight of the machine (425 kg).
- During transport, observe the high centre of gravity of the paper shredder!
- Place the shredder in its packaging on a smooth, level surface.
- Observe the instructions for unpacking.
- Remove the packaging.
- If you need to move the shredder through narrow doors, you can wait until it is at its final location before fitting the loading tray. Without the tray, the machine is only 805 mm wide.
- The shredder may only be placed in dry rooms on a hard, level floor – not on carpets. The floor load on each roller is approximately 107 kg.
- Place the machine in such a way that the power plug is easily accessible and the ventilation slots are free. Make sure the power cable is unobstructed and that nobody can tread on it.
- The shredder can be moved on its rollers. If using a forklift to transport a Solo machine, you must first remove the waste trolley. Then you can push the forks under the machine from the left or right side and lift it up.

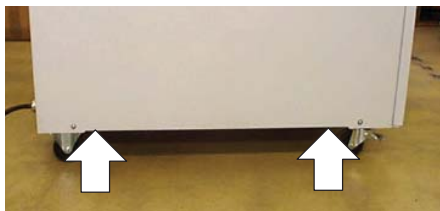

- **Solo machine:**
  - Lock the front castors by pressing down the brake lever.
  - Connect the power plug of the shredder to the 32A CEE mains socket.
- **Combination version:**
  - Push the shredder up to the baling press until the press and the outlet chute of the shredder touch.
  - Bolt the shredder and the baling press together.
  - Lock the front castors by pressing down the brake lever.
  - Connect the power plug of the shredder to the combination socket of the baling press.
- The machine must be connected to a power source which meets the specifications on the nameplate.

### Fitting the loading tray:

Fasten the tray on both sides at the top with the Phillips screws (1) and at the bottom with the 2 nuts (2).

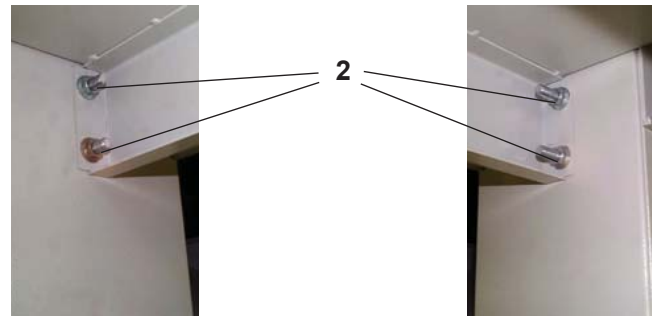
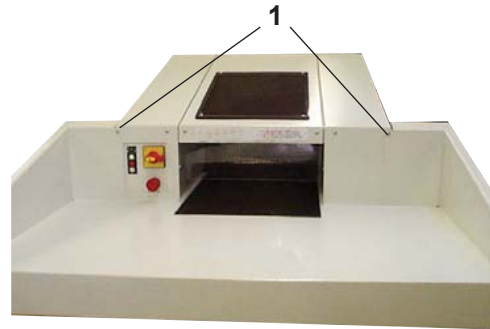

### Attaching the waste bag (Solo version)

- Open the front door and pull out the waste trolley.
- You can modify the trolley from a double-chamber to a single-chamber system by removing the brackets (1).

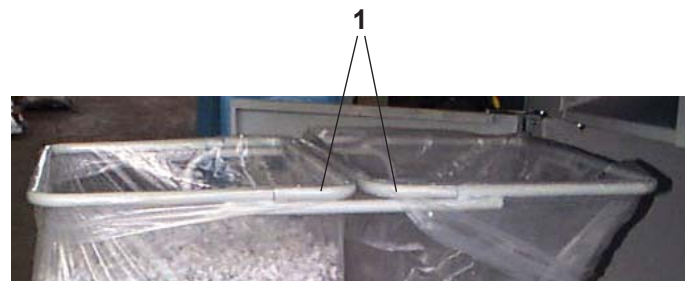

- Put in a new waste bag and fold it approximately 20 cm over the top frame tube. When using a two-chamber system, make sure that there is also around 20 cm of plastic foil below the brackets (1).
- Push in the waste trolley and close the front door.

## 6 Operating and display elements

**Paper jam or overload**  
Red LED

**Door open**  
Red LED

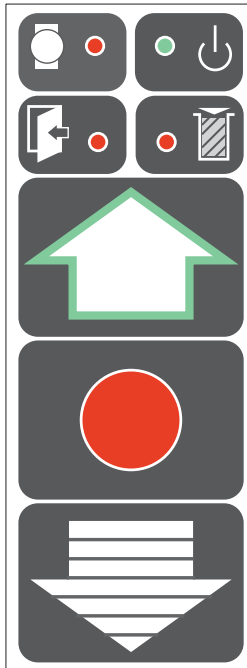

**Ready for operation**  
Green LED

**Waste bag full**  
Red LED

### Start button

The shredder switches on.  
The feed belt moves in the intake direction.

### Stop button

The cutting block and feed belt stop.  
The shredder is in standby mode.

### Reverse button

The cutting block and feed belt run in reverse.

## 7 Start-up

### Inspecting the safety devices



Check that the safety devices are working properly:

- At the start of each shift
- After any maintenance or repair work

Do not start the machine until you have checked the safety devices and found them to be in perfect working order. If any defect arises during operation stop the machine immediately and make sure it is corrected.

### Switching on the shredder



- Unlock the emergency stop button by turning it anticlockwise.



- Solo-version: Turn the main switch to the I position.  
Combination-version: Turn the main switch on the baling press to the I position.  
▶ The green "Ready for operation" LED lights up.

#### Note:

*There is a safety switch on the front door of the shredder. The machine can only be switched on when the door is shut.*



- Press the green start button.  
▶ The cutting block and feed belt start up.



#### Caution!

*The feed belt can run in reverse if the phase wires in the power plug are incorrectly connected.*

*Turn off the main switch immediately and pull out the power plug!*

*Have an electrician change two of the three phase wires*



**Checking the emergency stop button**

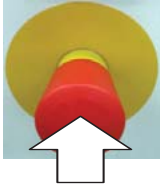

Press the emergency stop button while the machine is running. The shredder must switch off immediately. The cutting block and the feed belt must stop. The machine will only start again once you have pulled out the emergency stop button again.

**Inspecting the door switch**



- Open the front door.
  - ▶ The red "door open" LED must light up.
  - ▶ The cutting block and feed belt must stop.

After you close the door, the LED should go out and you can start the machine again by pressing the start button.



**Shredding material**



Place the material to be shredded on the loading tray and then place batches on the feed belt.

If material that is not supposed to be shredded is mistakenly placed onto the belt, never attempt to pull it out.



- Press the stop button.
  - ▶ The drive stops.



- Press the reverse button.
  - ▶ The cutting block and feed belt run in reverse.



- You can now remove the material from the belt and start the shredder again by pressing the start button.

**Waste bag full**



- ▶ The red LED on the keypad lights up. The shredder switches off automatically.



- Press the reverse button for approx. 3 seconds.
  - ▶ Part of the material is pulled back into the apparatus.

- Open the front door and shake the waste trolley.
  - ▶ The cut material spreads in the cut material sack and does not fall into the interior of the shredder.

- Pull the waste trolley out and change the cut material sack.



- Push the trolley back in and start the shredder again by pressing the green start button.

## Stopping the shredder



- Press the stop button.
  - ▶ The cutting block and feed belt stop.
  - ▶ The shredder switches to standby mode.

## Switching off the shredder



- Turn the main switch on the paper shredder or the baling press to **0**. You can secure the main switch in this position using a padlock.

## 8 Malfunctions

Check the following before calling customer service:

- Is the power plug connected?
- Is the shredder switched on?
- Is the front door closed?
- Is the waste bag full?
- Is there a paper jam in the shredder?
- Has the motor been overloaded?

### Paper jam (excessive paper feed)



- ▶ The red LED on the keypad blinks
- ▶ The cutting block automatically runs in reverse for several seconds.



#### **Caution!**

*The blade rollers can still cause injuries even while they are not running. Do not reach into the cutting apparatus! Wear safety gloves!*

*Do not alternately press the "Forwards" and "Reverse" buttons to remove the blockage. This will damage the shredder.*

- Take out the pile of paper.



- Press the green start button and put less paper on the feed belt.

### Electric motor overheated



- ▶ The red LED on the keypad lights up.
- ▶ The shredder switches off automatically.
- Let the motor cool down for 20 - 30 minutes.



- Press the green start button.

### Door open



- ▶ The red LED on the keypad lights up.
- ▶ The shredder switches off automatically.
- Close the front door.



- Press the green start button.

## 9 Maintenance and care

### Cleaning the cutting block

#### Strip cut machines: (1 x daily)



- Switch off the shredder.
- Squirt special cutting apparatus oil through the paper feed opening onto the blade rollers.  
Order no. 1.235.997.403 for a 250 ml bottle  
Order no. 1.235.997.501 for 5 litre container



- Let the cutting apparatus run forwards and backwards several times without feeding in any paper.  
▶ This loosens paper dust and particles.

#### Cross cut machines:

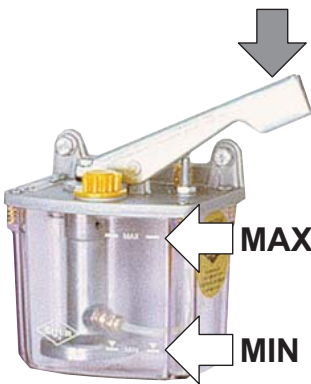

**If the cutting quality deteriorates or the machine becomes noisy:**

- Let the shredder run without feeding in any paper.
- Push the lever of the oiler down several times.
- Make sure the oil level in the container is between the MIN and MAX markings.  
Order no. 1.235.997.501 for 5 litre container



### WARNING

Service work may only be carried out by HSM Customer Service or by the service technicians of our contractual partners.

### Checking the chain tension (twice yearly)



- Switch off the shredder.
- Pull out the power plug.
- Remove the tray and the left cover panel.

The sag of the chain should be 4 – 10 mm.

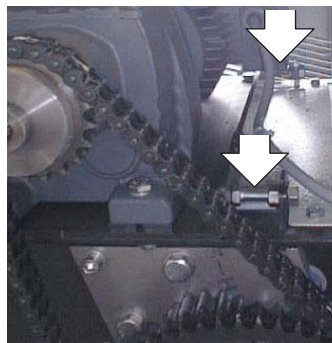
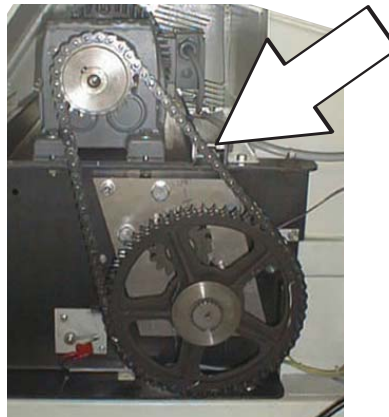

#### If you need to tighten the chain:

- Remove the right cover panel.
- Loosen the nuts and push the motor and the tensioning screws until the chain sags by 4 – 10 mm.
- Tighten the nuts again.
- Put the cover panels and the tray back on.

#### Note:

Do not tighten the chain too much, as this will cause premature wear on the chain and bearings.

## Greasing the drive chains and cogs (twice yearly)



- Switch off the shredder.



- Pull out the power plug.

- Remove the tray and the cover panels.
- Grease the cogs and the drive chains from the motor to the cutting apparatus, the cutting block to the feed belt and the cutting block to the regulating roller.  
Recommended lubricating grease: K2K in accordance with DIN 51502/DIN 51825
- Put the side cover panels and the tray back on.

## Tightening the feed belt

The feed belt should not slip when loaded with material.



- Switch off the shredder.

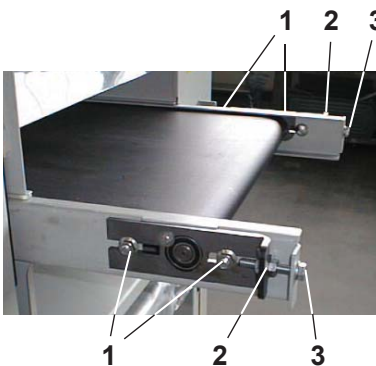

- Loosen the hex nuts (1) on the left and right sides of the snub roller.
- Loosen the lock nuts (2) of the tensioning bolts (3).
- Tighten the feed belt **evenly** using the tensioning bolts.

### Note:

Only tighten the feed belt until it stops slipping. The feed belt bearing may be damaged if it is tightened too much.

- Tighten the hex nuts on the snub roller and the lock nuts on the tensioning bolts again.



**You must check that the feed belt runs straight:**

Switch on the shredder and let it run for 10 minutes. During this time, the feed belt must run in the middle of the snub roller. If it slips to the left or right edge, you must alter the setting of the snub roller.

## Checking the feed belt for wear

The surface of the feed belt can become worn after long periods of use. If you can see the fabric inlay in the belt, it must be replaced. Please notify our customer service.

## Cleaning the shredder:

- Switch off the shredder and disconnect the power plug.
- Only use a soft cloth and mild soapy water for cleaning. Never use scouring agent, cleaning fluid, petroleum or thinners.

## 10 Disposal / Recycling

Dispose of the machine in an environmentally sound way at the end of its service life. Observe the current regulations when doing this. As legislation is subject to ongoing changes, we request that you contact your local authorities at the appropriate time. As the manufacturer, HSM would be glad to advise you on the disposal of your old machine.

## 11 Scope of supply, accessories

- Machine on pallet with a wooden frame, strapped with packing tape and packed in foil
- 4 waste bags, order no. 1.513.995.000 for 2-chamber system (Solo version)
- 1 waste bag, order no. 1.513.995.100 for 1-chamber system (Solo version)
- Special cutting block oil  
For strip cut machines: 250 ml bottle, order no. 1.235.997.403  
For cross cut machines: 5 l container with spout, order no. 1.235.997.501
- Operating manual
- Accessories: strip curtain, order no. 1.513.050.445

**12 Technical data**

Cutting type	Strip cut		Cross cut		
Cut size (mm)	11.8	5.8	5.8 x 50	3.9 x 40	
Safety level DIN 66399	P-1, O-1, T-1, E-1	P-2, O-2, T-2, E-2	P-3, O-2, T-3, E-2	P-4, O-3, T-4, E-3, F-1	
Safety level DIN 32757 – 1	1	2	3	3	
Cutting capacity (sheets), DIN A4,	70g/m <sup>2</sup>	180	130	120	95 - 100
	80g/m <sup>2</sup>	144	104	96	80 - 85
Cutting speed	210 mm/s		220 mm/s		
Effective width	428 mm				
Weight	approx. 425 kg				
Waste container volume (Solo machines)	460 l				
	2-chamber system 2 x 230 l				
Power supply	3 x 400 V, 50 Hz		3 x 220 V, 60 Hz		
Rated power	4 kW				
Fuse rate	20 A		40 A		
Plug	CEE 32A		250V/30A/3P+PE		
Ambient conditions in operation: Temperature Relative humidity Height above sea-level (MSL)	-10 °C to +40 °C max. 90 %, without condensation max. 2,000 m				
Sound level (idling / under load)	61 dB(A) / 75 dB(A)				

**EC Declaration of Conformity**

The manufacturer **HSM GmbH + Co. KG**, Austraße 1 - 9, 88699 Frickingen / Germany hereby declares that the machine document shredder **HSM FA 400.2** corresponds to the health and safety requirements of the following EC directives listed below due to its conception and design of the version in which it was put into circulation by us:

Machinery directive 2006 / 42 / EC  
EMC directive 2004 / 108 / EC

Applied standards and technical specifications:

- EN 394:1993 + A1:2008
- EN 12100-1:2003 + A1:2009
- EN 55014-1:2006
- EN 61000-3-2:2006
- EN 61000-3-3:1995 + A1:2001 + A2:2005
- EN 13849-1:2008
- EN 12100-2:2003 + A1:2009
- EN 55014-2:1997 + A1:2001
- EN 60950-1:2006

Authorised representative for the compilation of technical documentation: Hubert Kötzing, HSM GmbH + Co. KG

Frickingen, 02.08.2013



ppa. Hubert Kötzing - Head of Environmental Engineering Product Development