

# ***Keencut 115" Hot Cut System with HSGM Heat Knife - 61749***

Instruction Manual



*Provided by*

**MyBinding.com**

*When Image Matters.*

Call Us at 1-800-944-4573

# SABRE HotCut SYSTEM

*Inspired Design – Precision Engineering*

## USER INSTRUCTIONS

Thank you for choosing the Keencut SABRE HotCut System. Every effort has been made to bring you a precision engineered product with the promise of many years of valuable service. In order to obtain maximum benefit from your machine please read these instructions carefully. For advice and assistance or replacement parts please contact your distributor or Keencut Ltd.

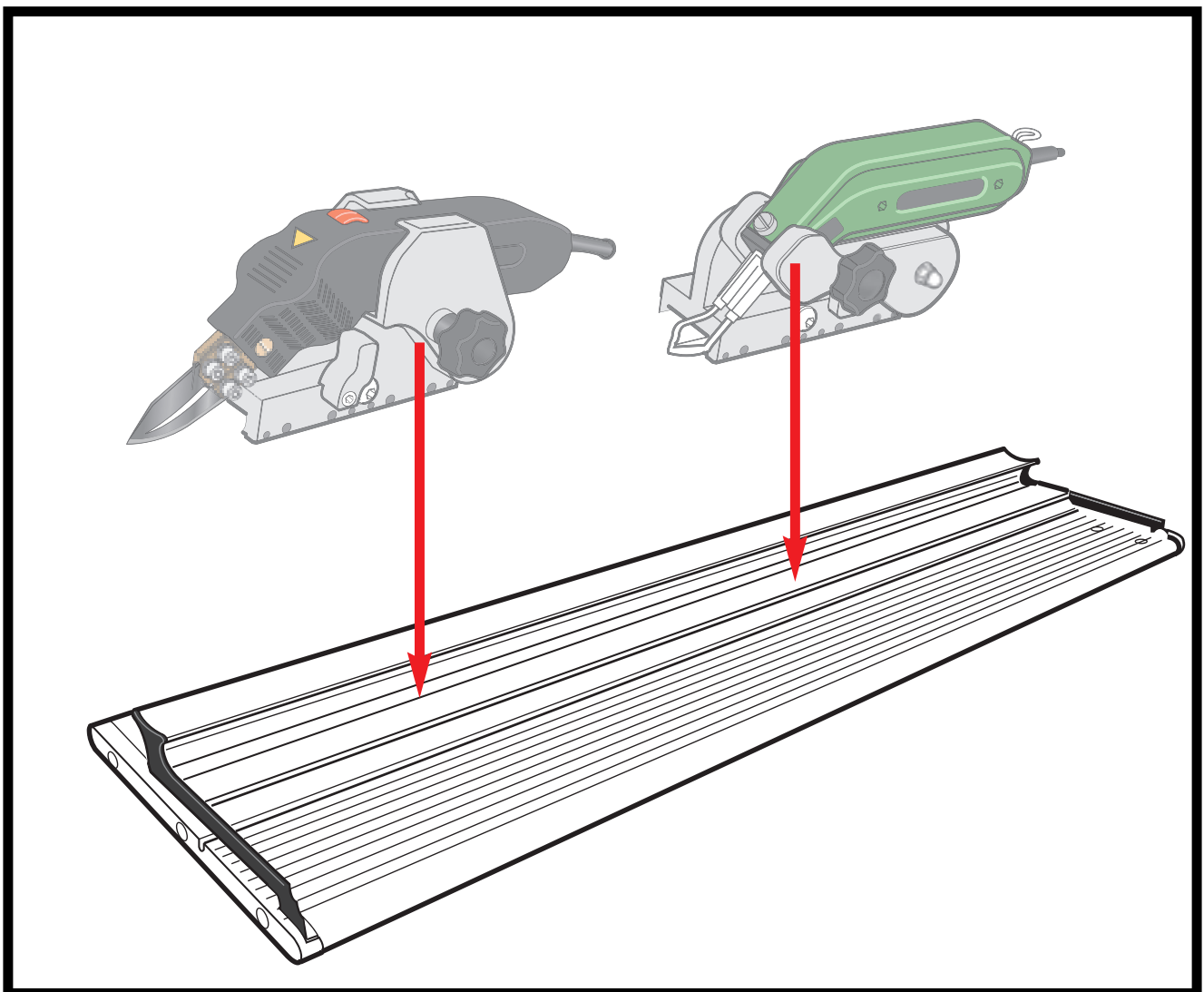

# Your SABRE HotCut SYSTEM

**NOTE:** The Hot Knife its holder and blade are not included.

The SABRE HotCut System has been designed to accept:

- Either a hot knife attachment which accepts the HSG-0 heated knife manufactured by HSGM and will need to be fitted with a Type 'R' blade.
- Or a hot knife attachment which accepts the AZ manufactured TC20 heated knife fitted with a T 013/45 blade.

**NOTE:** Other blades recommended by the heated knife manufacturers can be used providing they are of a suitable length and shape.

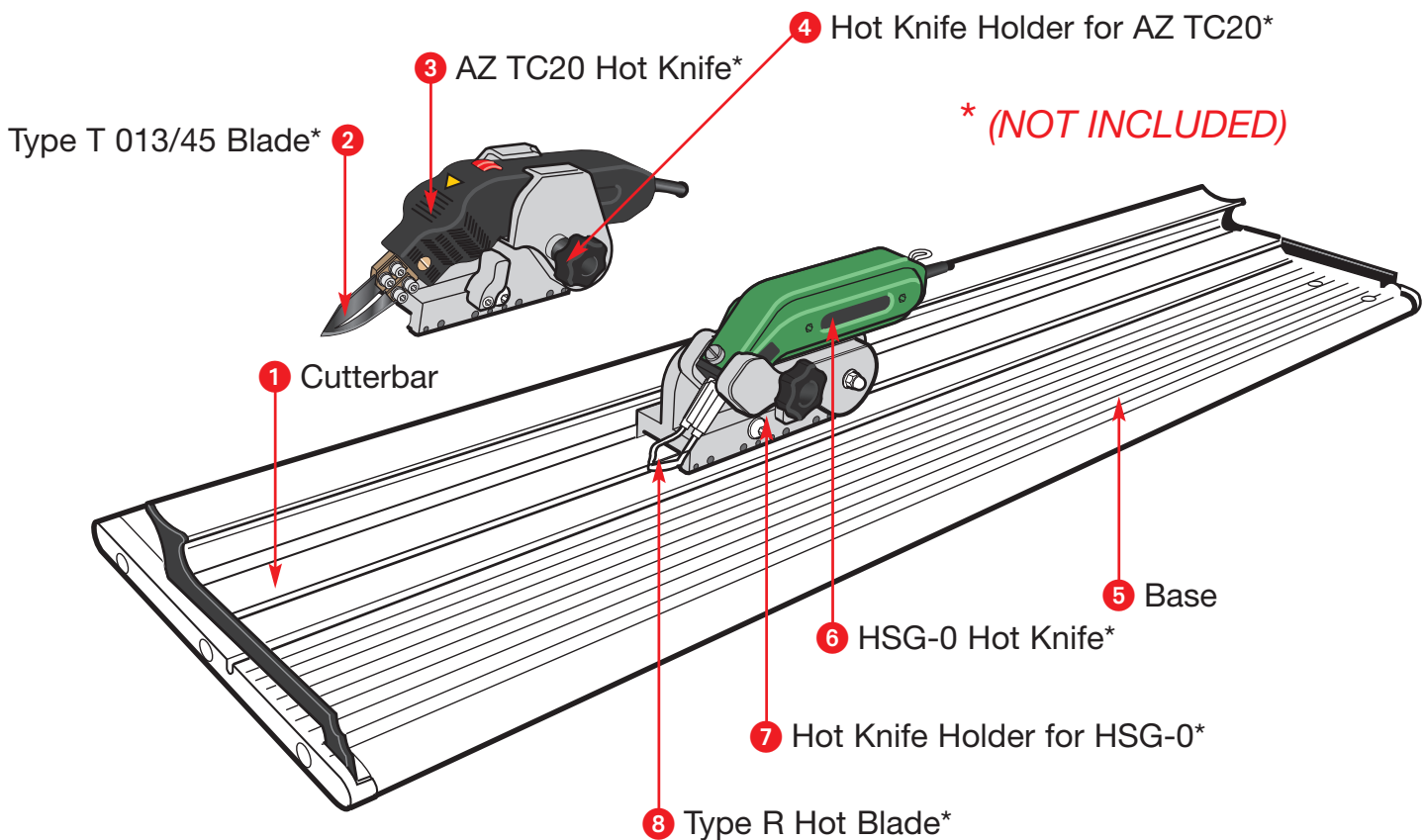

**Cutter - Available in three sizes:**

■ SHC90	Sabre HotCut System	90cm	- 36" cut length
■ SHC190	Sabre HotCut System	190cm	- 75" cut length
■ SHC290	Sabre HotCut System	290cm	- 115" cut length

**You should have:**

Self-adhesive Silicon Cutting Strip  
5mm Allen key  
4mm Allen key  
2mm Allen key



A Heat Resistant Silicon strip is included that can be applied to the surface of a strip of a heat resistant material to provide a cutting surface. MDF, Hardboard or Aluminium Composite (such as Dibond) all work well. For long term consistent use we recommend cutting directly onto 6mm (1/4") toughened/tempered glass.

## Fitting the End stop

Each Hot Knife Attachment comes with an End Stop and fixing screw which should be fitted to the left hand Lift Arm of the Sabre HotCut as shown.

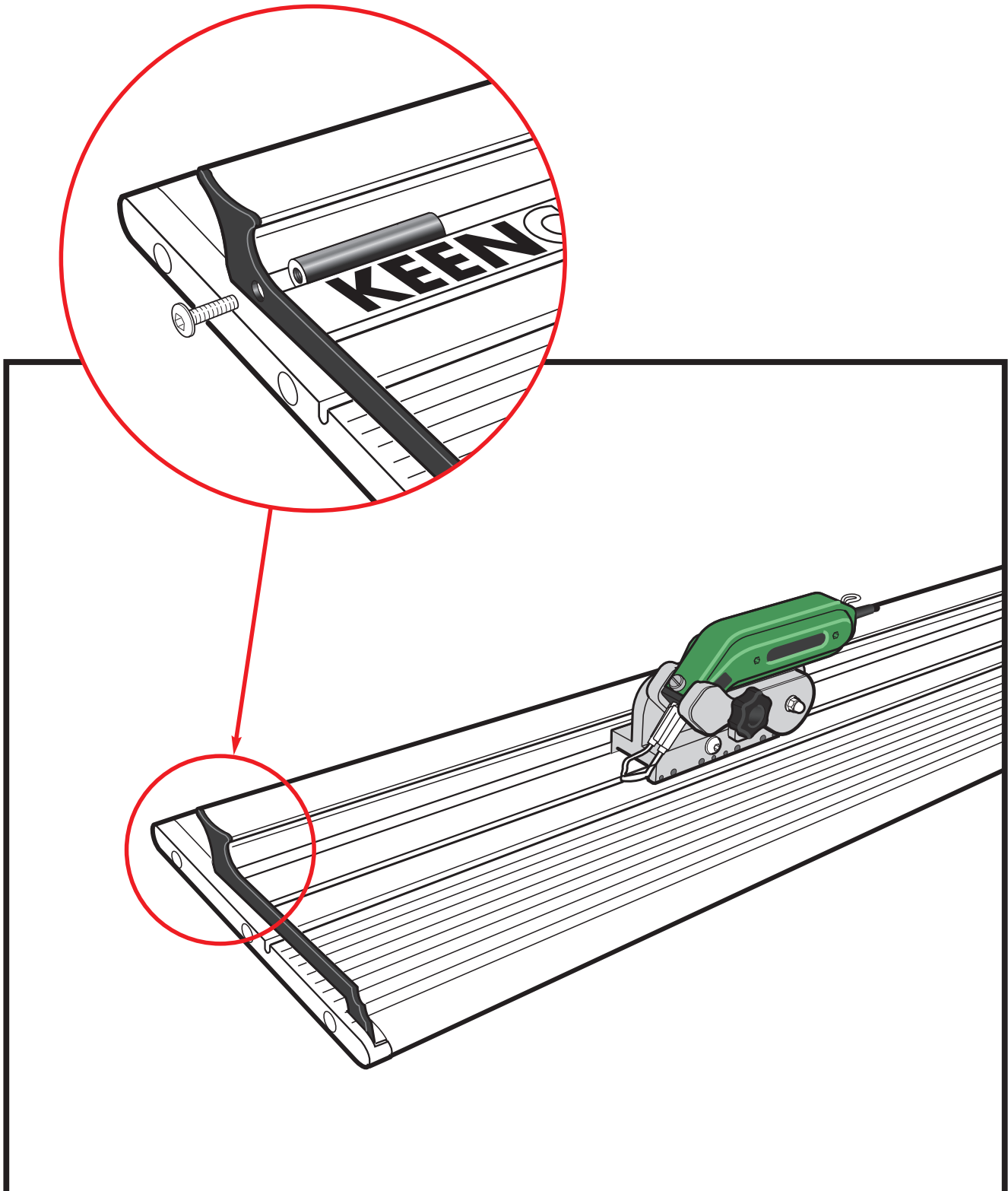

## Fitting the HSGM Hot Knife holder

The HSGM Hot Knife attachment has been designed to accept the HSG-0 Heated Knife fitted with a Type 'R' blade.

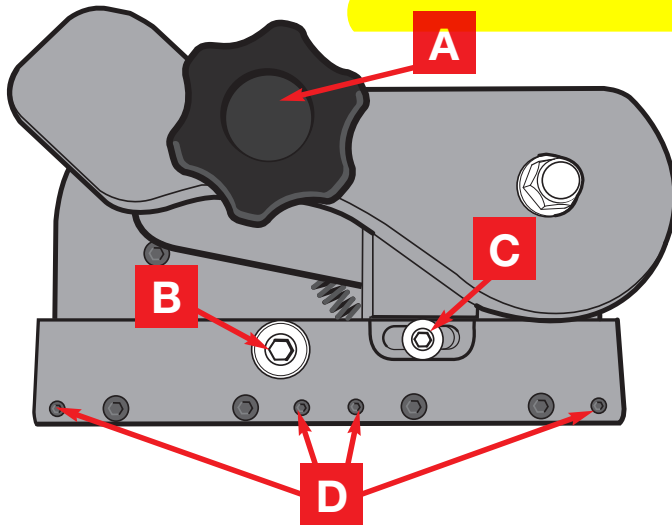

**A** = Tighten to clamp Hot Knife into holder

**B** = Loosen to open up the base when fitting on to slideway

**C** = Loosen screw and slide block to adjust point at which the trigger switches the hot knife on.

**D** = Sliding bearing adjustment screws.

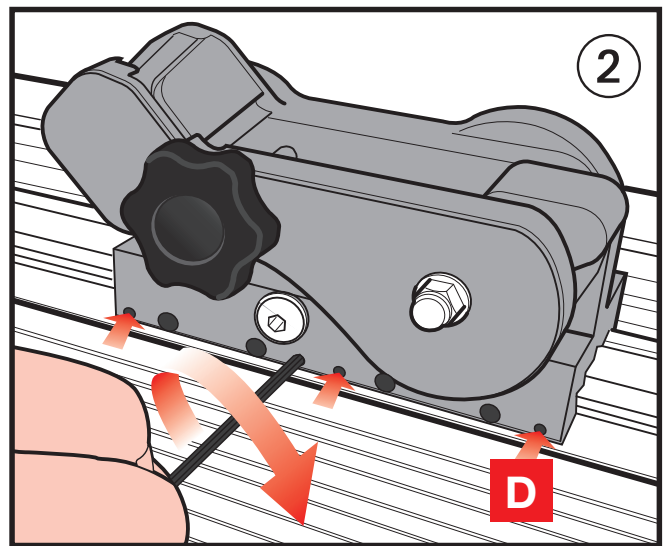
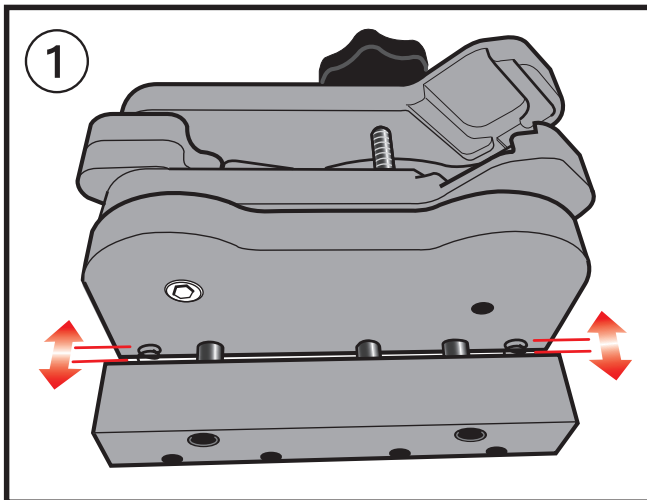

**A heatproof protective surface must be placed on the base of the machine under the fabric.**

- ① To fit the attachment to the slideway loosen screw **B** to create a gap in the base sufficient for it to be lowered onto the slideway.

Tighten screw **B** and check that the cutting head runs smoothly.

- ② If the head is too loose or too tight when moved it can be adjusted, place the long end of the 2mm Allen key provided onto one of the four adjustment screws **D** and very gradually tighten it with one hand whilst moving the Cutting Head slowly with the other. Once you feel the sliding motion start to tighten undo the screw the smallest amount so the Cutting Head just slides easily.

Repeat this on the other screws in turn, two or three smaller adjustments on each screw may be needed to achieve an easy sliding movement with zero side play.

**NOTE:** Once the sliding bearings have been adjusted the attachment should not need readjusting if the cutting head is removed and replaced at a later time. It is however, important that screw **B** is fully tightened each time the cutting head is fitted to the machine.

## Fitting and use of the HSGM HOT KNIFE

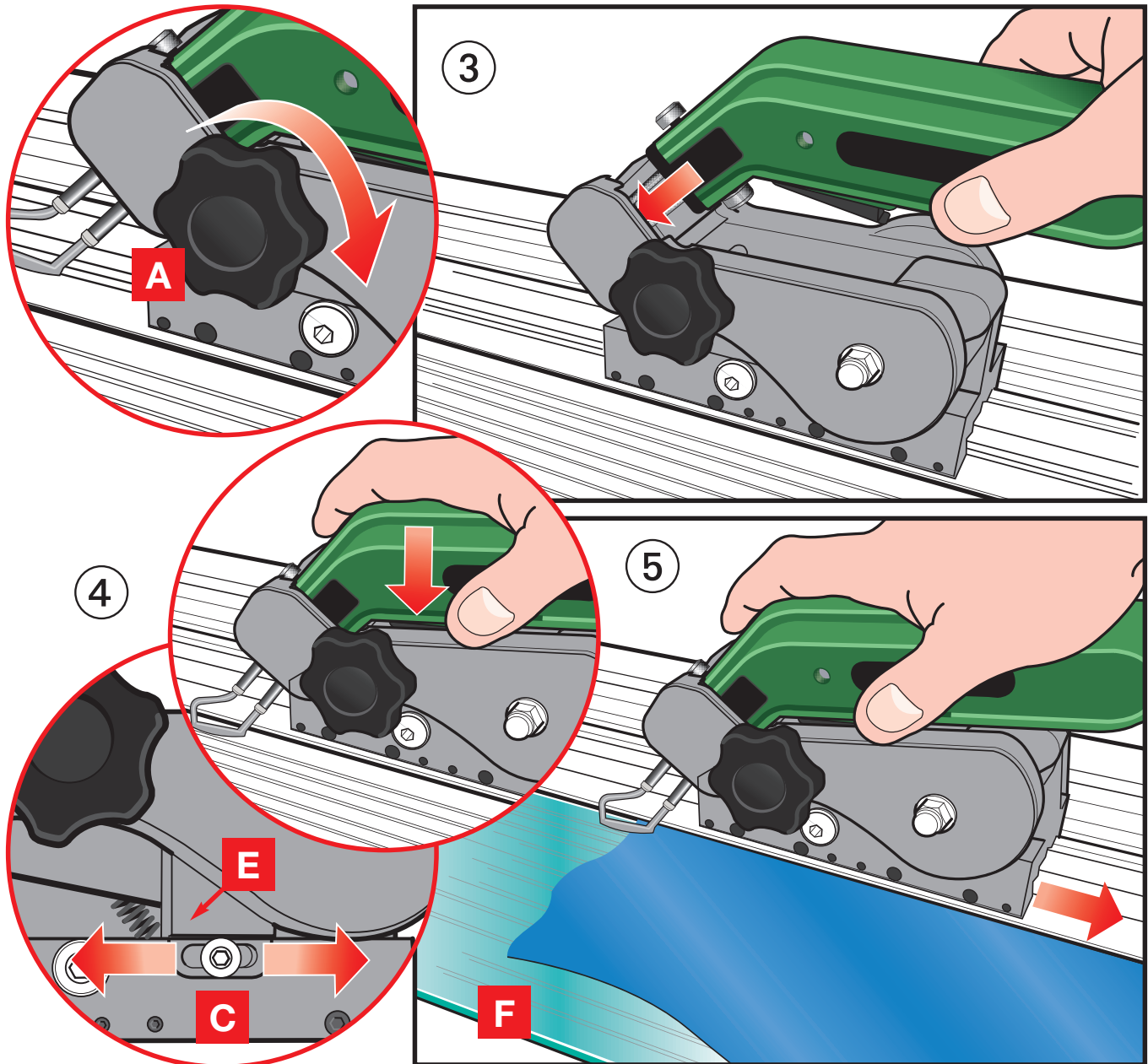

- ③ To fit the Hot Knife, simply insert it into the holder ensuring the nose of the Hot Knife is seated fully into its recess.

Tighten knob **A** and check the Hot Knife is fully gripped in position, the blade should cut about 2-3mm (1/16" to 1/8") away from the edge of the slideway.

- ④ Depress the Hot Knife and the trigger should switch the heat on prior to it coming into contact with the fabric.

The trigger can be adjusted to alter the position the heat is switched on by loosening screw **C** and sliding the Trigger Block **E** left or right.

- ⑤ Once the blade has reached the correct temperature press down to bring the blade in contact with the fabric and slide the cutting head to the right to seal and cut it.

**A heatproof protective surface F must be placed on the base of the machine under the fabric.**

## Fitting the AZ Hot Knife holder

The AZ Hot Knife attachment has been designed to accept the TC 20 Heated Knife and will need to be fitted with a Type 'T 013/45' blade.

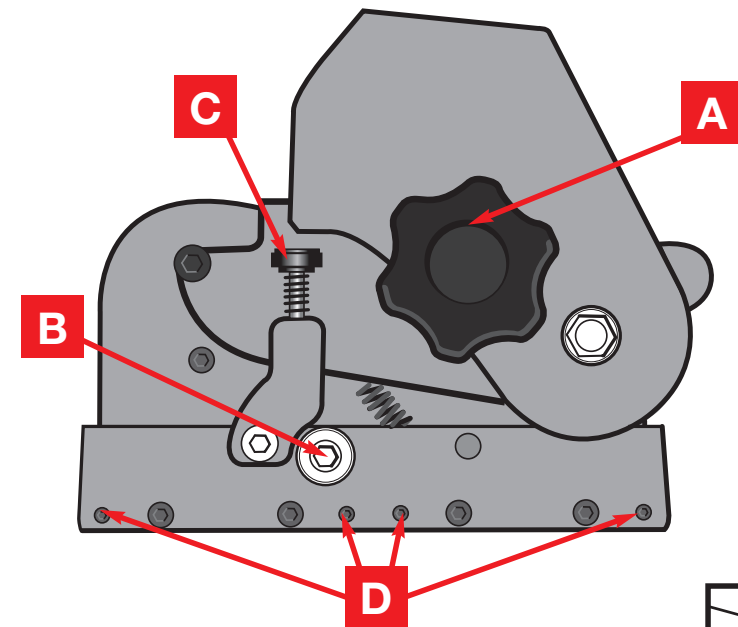

**A** = Tighten to clamp Hot Knife into holder

**B** = Loosen to open up the base when fitting on to slidaway

**C** = Rotate knob to adjust point at which the trigger switches the hot knife on

**D** = Sliding bearing adjustment screws.

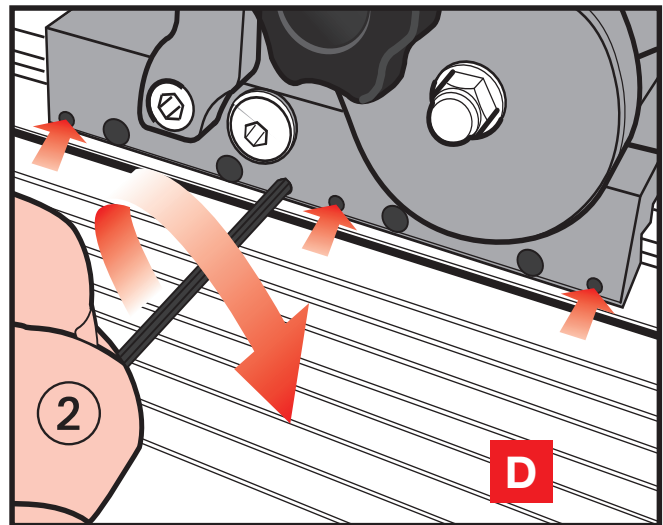
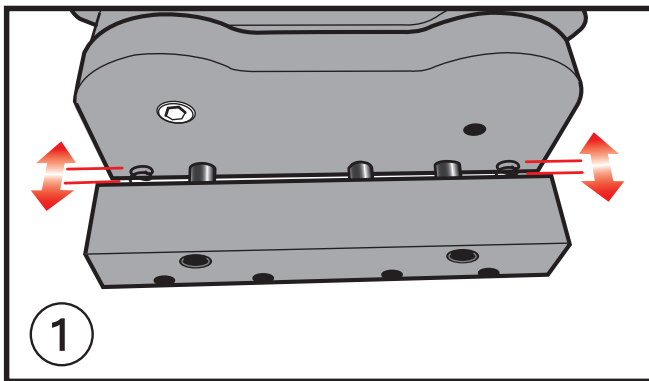

**A heatproof protective surface must be placed on the base of the machine under the fabric.**

- ① To fit the attachment to the slidaway loosen screw **B** to create a gap in the base sufficient for it to be lowered onto the slidaway.

Tighten screw **B** and check that the cutting head runs smoothly.

- ② If the head is too loose or too tight when moved it can be adjusted, place the long end of the 2mm Allen key provided onto one of the four adjustment screws **D** and very gradually tighten it with one hand whilst moving the Cutting Head slowly with the other. Once you feel the sliding motion start to tighten undo the screw the smallest amount so the Cutting Head just slides easily.

Repeat this on the other screws in turn, two or three smaller adjustments on each screw may be needed to achieve an easy sliding movement with zero side play.

**NOTE:** Once the sliding bearings have been adjusted the attachment should not need readjusting if the cutting head is removed and replaced at a later time. It is however, important that screw **B** is fully tightened each time the cutting head is fitted to the machine.

## Fitting and use of the AZ HOT KNIFE

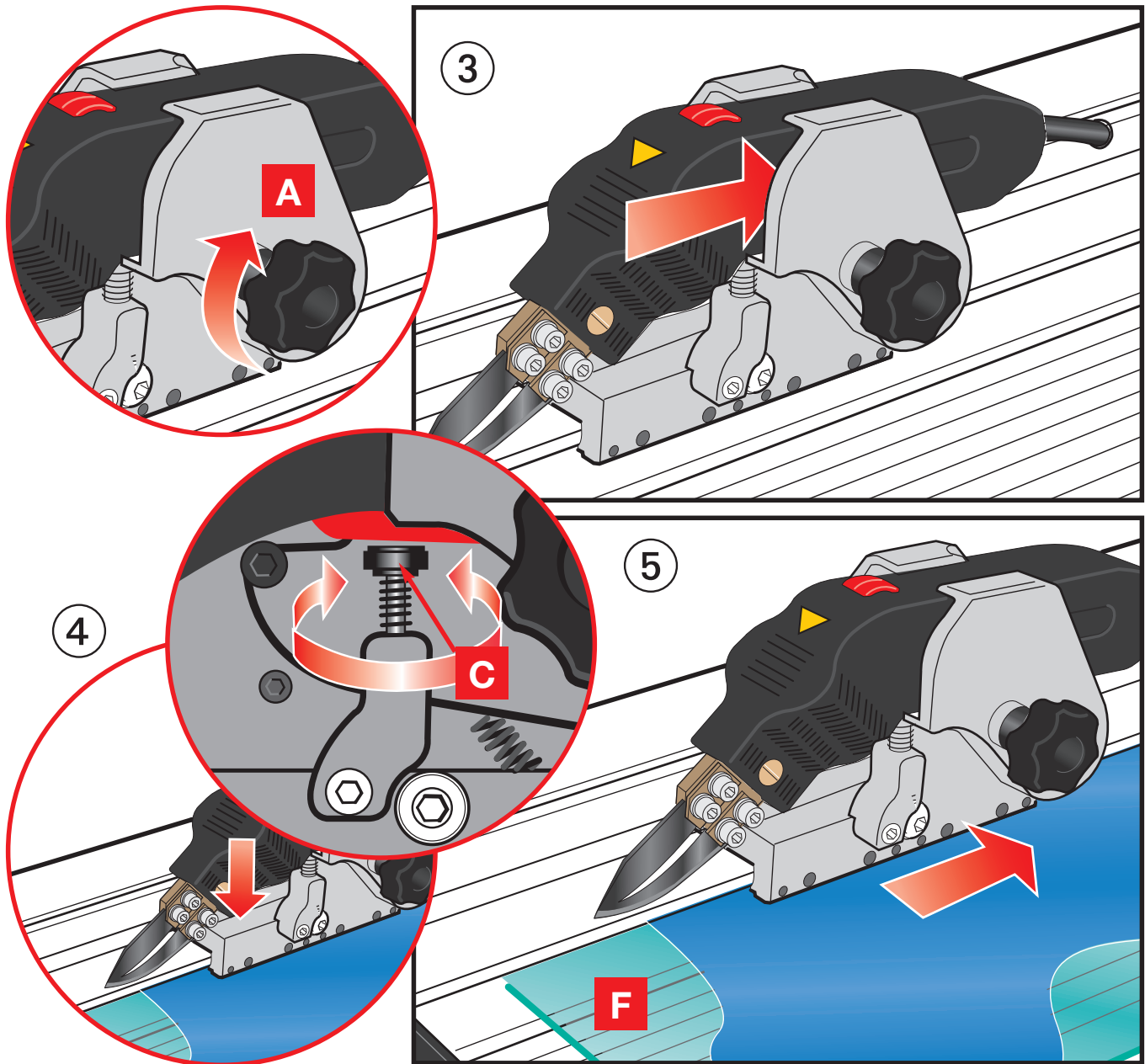

- ③ To fit the Hot Knife, simply insert it into the holder ensuring the Hot Knife is seated fully into its recess. Tighten knob **A** and check Hot Knife is fully gripped in position, the blade should cut about 2-3mm (1/16" to 1/8") away from the edge of the slideway.
- ④ Depress the Hot Knife and the trigger should switch the heat on prior to it coming into contact with the fabric.  
**The trigger can be adjusted to alter the position the heat is switched on by turning knob C.**
- ⑤ Once the blade has reached the correct temperature press down to bring the blade in contact with the fabric and slide the cutting head to the right to seal and cut it.

**A heatproof protective surface F must be placed on the base of the machine under the fabric.**

A Heat Resistant Silicon strip is included that can be applied to the surface of a strip of a heat resistant material to provide a cutting surface. MDF, Hardboard or Aluminium Composite (such as Dibond) all work well. For long term consistent use we recommend cutting directly onto 6mm (1/4") toughened/tempered glass.