



FLEXO PLATE CUTTER

Inspired Design - Precision Engineering

USER INSTRUCTIONS

Thank you for choosing the Keencut FLEXO PLATE CUTTER. Every effort has been made to bring you a precision engineered product with the promise of many years of valuable service. In order to obtain maximum benefit from your machine please read these instructions carefully.

For advice and assistance or replacement parts please contact your distributor or Keencut Ltd.

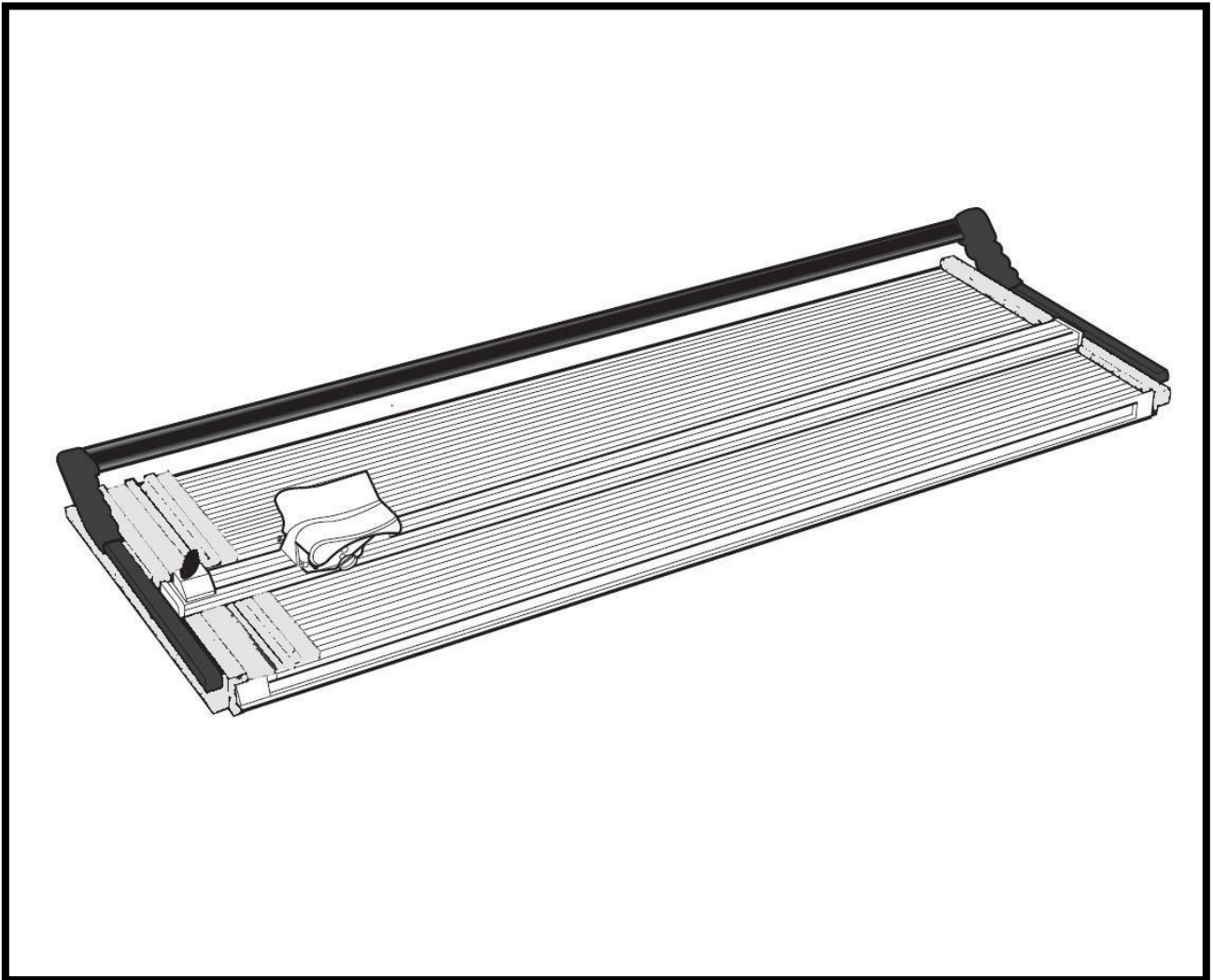

MyBinding.com

9620 NE Tanasbourne Dr. Suite 250 Hillsboro, OR 97124

Toll Free: 1-800-944-4573

Local: 503-640-5920

2 Know your Flexo Plate Cutter**3 Operation**

The Blade Cartridges

Using the 5° Offset Cutter

Replacing the Sightline Strip

Using the Bevel Cutter

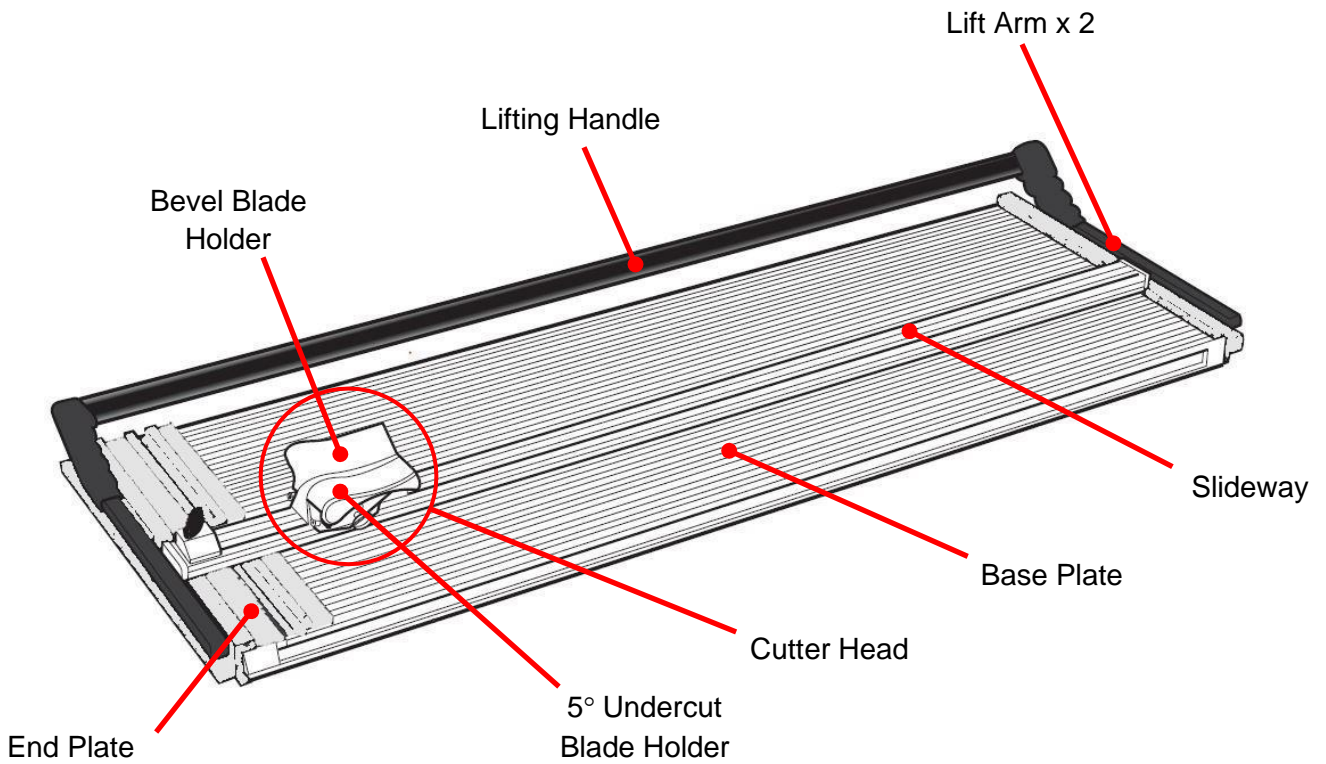

Available in five sizes:

	Cutting length	Rubber feet
FPC18	46cm - 18"	4
FPC32	81cm - 32"	4
FPC50	127cm - 50"	6
FPC64	163cm - 64"	8
FPC84	213cm - 84"	10

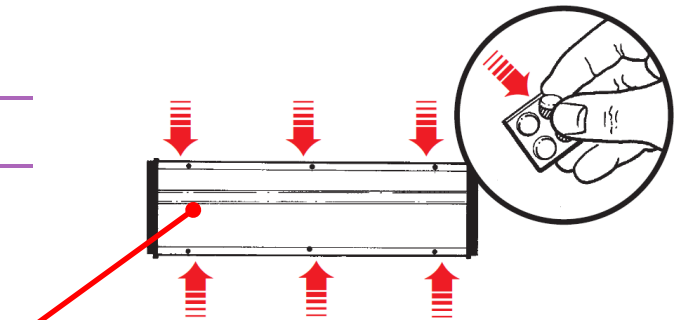

Rubber feet to be equally spaced along left and right edges of the base.

You should have:

Cutting Mat

- 15x TECH D 012 Blades 100x CA50-017
- 15x TECH S 012 Blades 100x CA50-021
- 15x TECH S 015 Blades 100x CA50-030
- 100x Medium Duty Blades 100x CA50-019
- 3mm Allen key

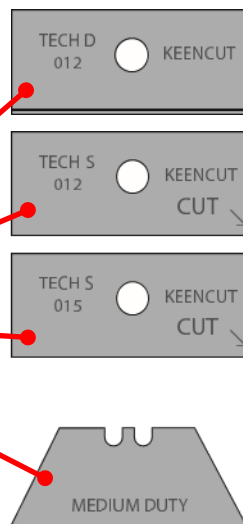

PLEASE NOTE:

TECH S blades are ground on a Single edge and marked with an arrow and 'CUT' designating the corner to use when inserted in the Bevel Blade Holder. Use the opposite corner when using in the 5° Blade holder.

Operation

The Blade Cartridges

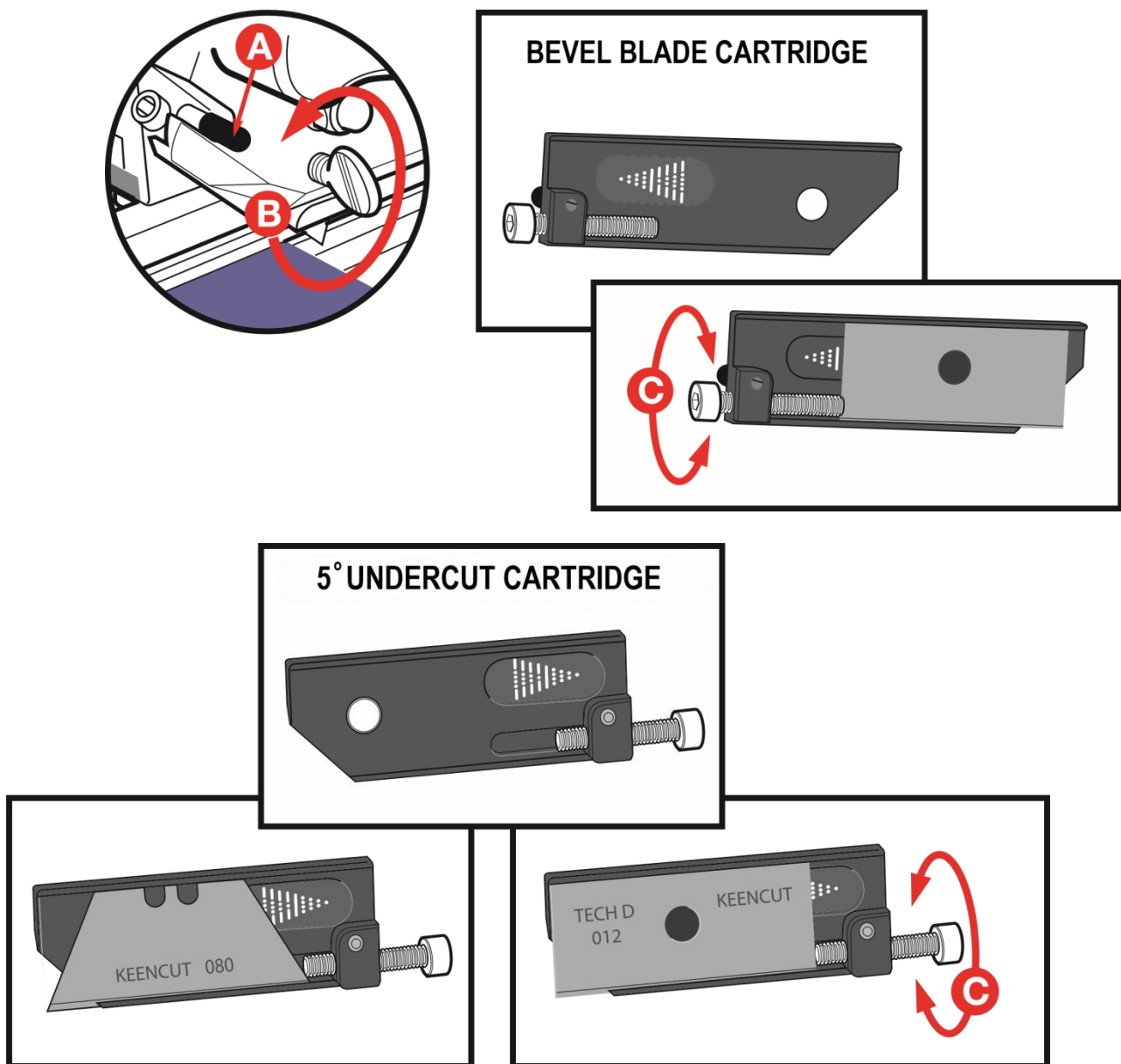

Both the bevel and 5° undercut blade holders are fitted with Blade Cartridges, to release the cartridge from either of the blade holders slacken the blade clamping screw (B) and pull the cartridge out, gripping the black plastic pin (A).

The blade is held onto the cartridge by a strong magnet, place the blade between the two raised edges and slide it so the back edge of the blade touches the depth adjustment screw. To adjust the blade depth turn the adjustment screw (C) clockwise to extend the blade length and counter-clockwise to reduce it. Always check that the blade is properly located in the cartridge before loading it into the blade holder.

Each cartridge has a different coloured label to help with identification and calibration if pre-set to suit different thicknesses of board. Additional blade cartridges are available from your Keencut distributor.

Experimentation with blade types is advised to product optimum results with the various thicknesses and types of flexo plate used.

Using the 5° Offset Cutter

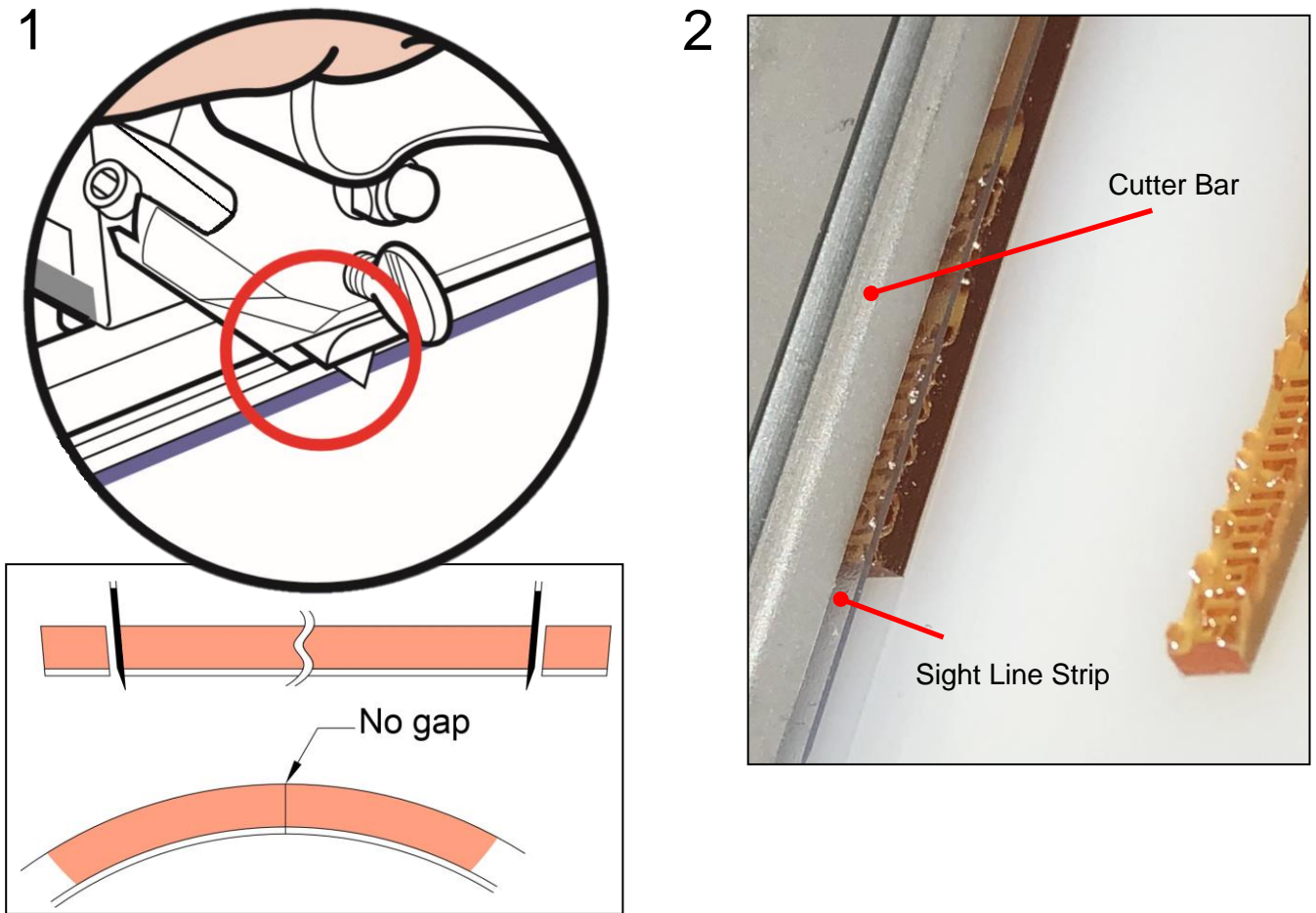

1. The blade holder on the right hand side of the cutting head produces a 5° undercut. This enables the flexo plate to be joined on the roller and leave no gap at the join. Without the undercut the flexo plate will meet the base of the material but will leave a small gap at the outer surface of the plate.
2. The right hand edge of the cutter bar is fitted with a sight line strip. This gives an exact indication where the blade will cut and therefore makes accurate alignment of the plate much easier.

When cutting, the bulk of the flexo plate should be on the left hand side, under the cutter bar, trim the first edge with the waste on the right hand side of the cutline. Rotate the plate 180° then trim the second edge.

There are a number of different types of blade included with the cutter to allow for experimentation. There are however a few general rules to bear in mind:

- TECH S blades are ground on a Single edge and marked with an arrow and 'CUT' designating the corner to use when inserted in the Bevel Blade Holder. Use the opposite corner when using in the 5° Blade holder.
- When using the single sided blades, the flat side of the blade should always be facing towards the central part of the cutting head. Irrespective of which blade holder is used, when it is mounted in the cutting head (as in 1.) the ground edge of the blade should be seen.

Using the 5° Offset Cutter

The following process has been found to be very successful but experimentation is encouraged:

Place a single edge blade (TECH S 012) in the 5° cutter such that the flat side of the blade is to the left when mounted in the blade holder, i.e. when viewing the tip of the blade when mounted in the cutting head you should see the ground edge of the blade.

Check the cutting mat is in place.

Set the blade depth so it will only just cut through the plate. Mount the plate with the smooth side down and the plastic cutting mat underneath.

Make a rough cut about 5mm ($\frac{1}{4}$ ") away from the intended finish cut line (on the waste side) just to remove the bulk of the plate.

Line up the plate to cut exactly down the final line.

When cutting, depress the blade holder a little and take a shallow cut in one smooth continuous motion then make further multiple cuts using firm continuous strokes, do not cut too slowly or hesitate. Some plates may cut well with just one smooth stroke.

The flat face of the blade will guide itself down the cut face of the main body of the flexo plate and the ground edge will push the $\frac{1}{4}$ " strip of waste away easily therefore reducing any side pressure on the blade.

Replacing Sightline Strips

Although the sightline strips are very durable they can become damaged and worn with use, replacements are available through your Keencut distributor.

Place a light pencil mark on the cutter bar where the strip starts and finishes

Remove the old strip by just peeling it off, remove any adhesive left on the cutter bar but be careful not to affect the adhesive holding on the green silicon tape.

Release the paper backing from the new strip and position it according to the pencil marks. Be careful not to overlap the green silicon tape, it must lie alongside it.

Using a TECH S blade mounted in the normal way, very lightly draw the blade down the surface of the strip, repeat a number of times until the strip parts. Do not be tempted to cut through in just a few strokes as it could lead to an inaccurate result.

Operation

Using the Bevel Cutter

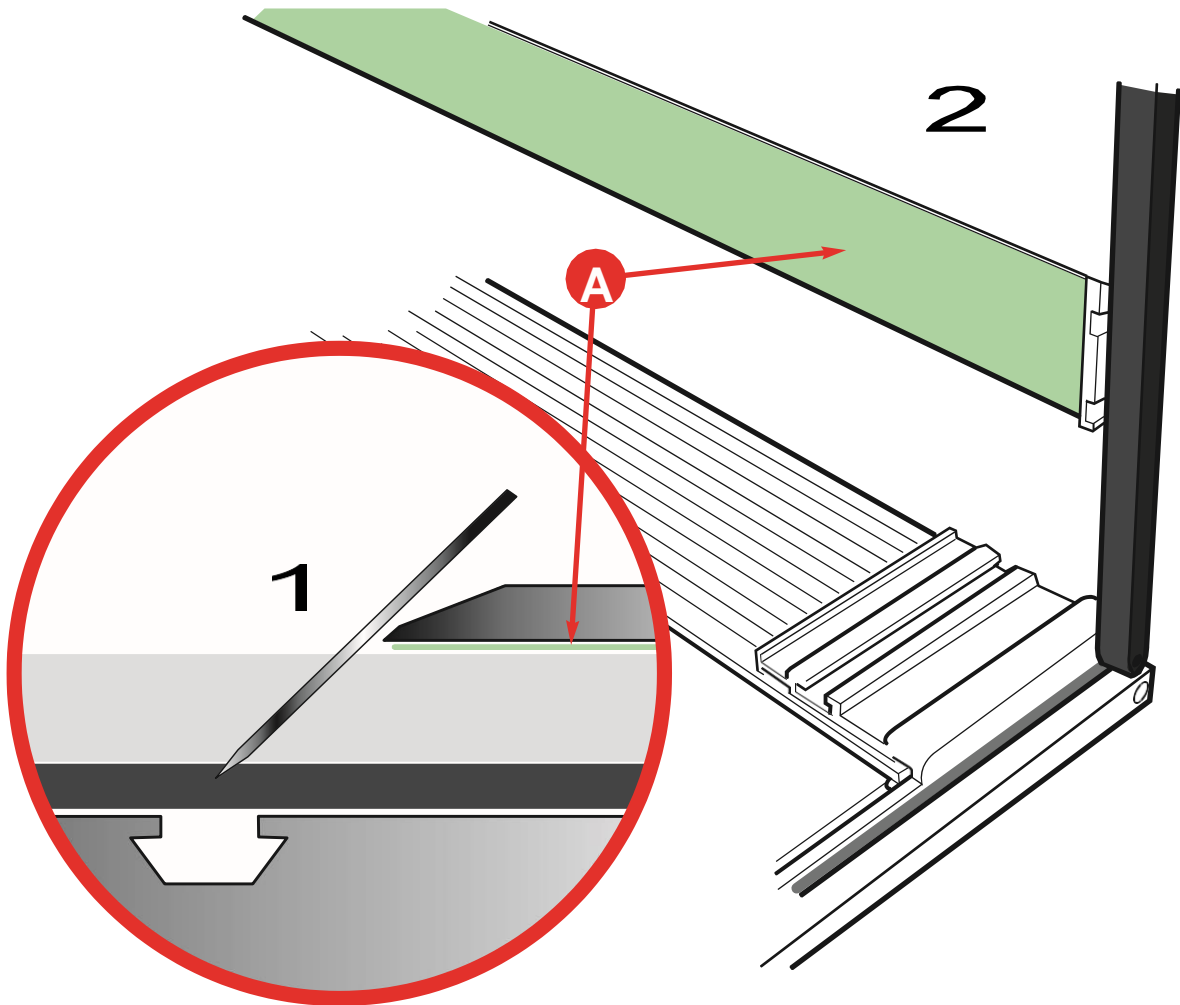

1. When cutting Flexo Plate always use a cutting mat to cut onto and ensure the blade depth is set to a minimum to cut through the material thickness. A cutting mat is supplied but experimentation using other materials such as good quality card can give good results.
2. It is important that the silicon grip tape (A) on the underside of the cutter bar is kept clean to hold the flexo in place.

If it becomes dirty through use clean it with a cloth moistened with diluted detergent.

Helpful hints:

- To eliminate entry and exit burrs, push the blade into the flexo, through the base, to start your cut.
- If you cut with the base side up, place the foam protector sheet (used for shipping between each flexo plate), on the base board, to protect the emulsion side from scratching.
- To obtain smooth clean edges and avoid fracturing (especially on thicker flexo plates) make multiple passes and frequent blade changes.



MyBinding.com

9620 NE Tanasbourne Dr. Suite 250 Hillsboro, OR 97124

Toll Free: 1-800-944-4573

Local: 503-640-5920