

Semi-Automatic Carton Sealer

Model:

PP-556AU

This operator-fed machine is excellent for all types of boxes.



* Shown with Optional Infeed and Discharge Roller Conveyor & Casters.

Semi-Automatic Operator-Feed "Random" Carton Sealer

- Automatic Adjustment to Random Box Sizes.
- 2 Side Drive Belts with 2 Top Drive Belts Provide Positive Grip Pressure to Convey Even the Heaviest of Boxes.
- Featuring Our New "Piranha" Tape Head with "Easy Thread Design" with Optimizer Arm.
- Machine Comes Complete with Adjustable Height Legs, Power Cord and 110 Volt Plug.



2 Top Drive Belts with 1/4 HP Motors and Emergency Stop Switch



Heavy Duty Dual Side Drive Belts Move Inward to Automatically Center Box



New "Piranha" Tape Head Features An Easy Thread Design with Optimizer Arm

PP-556AU CARTON SEALER

The operator simply packs the corrugated carton closes the top flaps and feeds the box into the machine and activates the lower limit switch, the top drive belts move downward and the 2 side drive belts move inward to center the box, the drive belts turn on and drive the box through the machine. The PP-556AU applies a single tape strip to both the top and bottom of the case simultaneously. This 4 belt drive design is a heavy duty versatile machine designed for dependable performance and easy operation. The PP-556AU will easily adjust in seconds to process a different size carton. Excellent for all types of boxes. The PP-556AU will process up to 20 cartons per minute (depending on box size).

STANDARD FEATURES:

- Piranha Tape Head with "Easy Thread" Design
- Interchangeable Tape Heads
- Automatic Adjustment to Random Size Boxes
- 2 Side Drive Belts
- 2 Top Drive Belts
- Fully Adjustable Legs

OPTIONAL FEATURES:

- 3" (72mm) Tape Heads
- Infeed Conveyor
- Exit Conveyor
- Stainless Steel Frame
- Heavy Duty Locking Casters

CARTON SIZE: LENGTH: 12" min. to Infinite Length
 WIDTH: 8" min. to 20" max. (9" on 3" Head)
 HEIGHT: 6" min. to 20" max.

MACHINE SIZE: 51"L x 35"W x 64"H

MACHINE SPEED: 75ft./min. up to 20 cartons per minute. Production rate depends on carton size and operator dexterity

ELECTRICAL: 110 Volt, 1 Phase, 10 Amp

WEIGHT: 715 lbs. Shipping Weight: 775 lbs.

MAX BOX WEIGHT: 75lbs.

TAPE HEAD SPECS: 2" (48mm) Wide - 1,000 yard or 1,500 yard rolls.

WARRANTY: 1 Year Limited Warranty

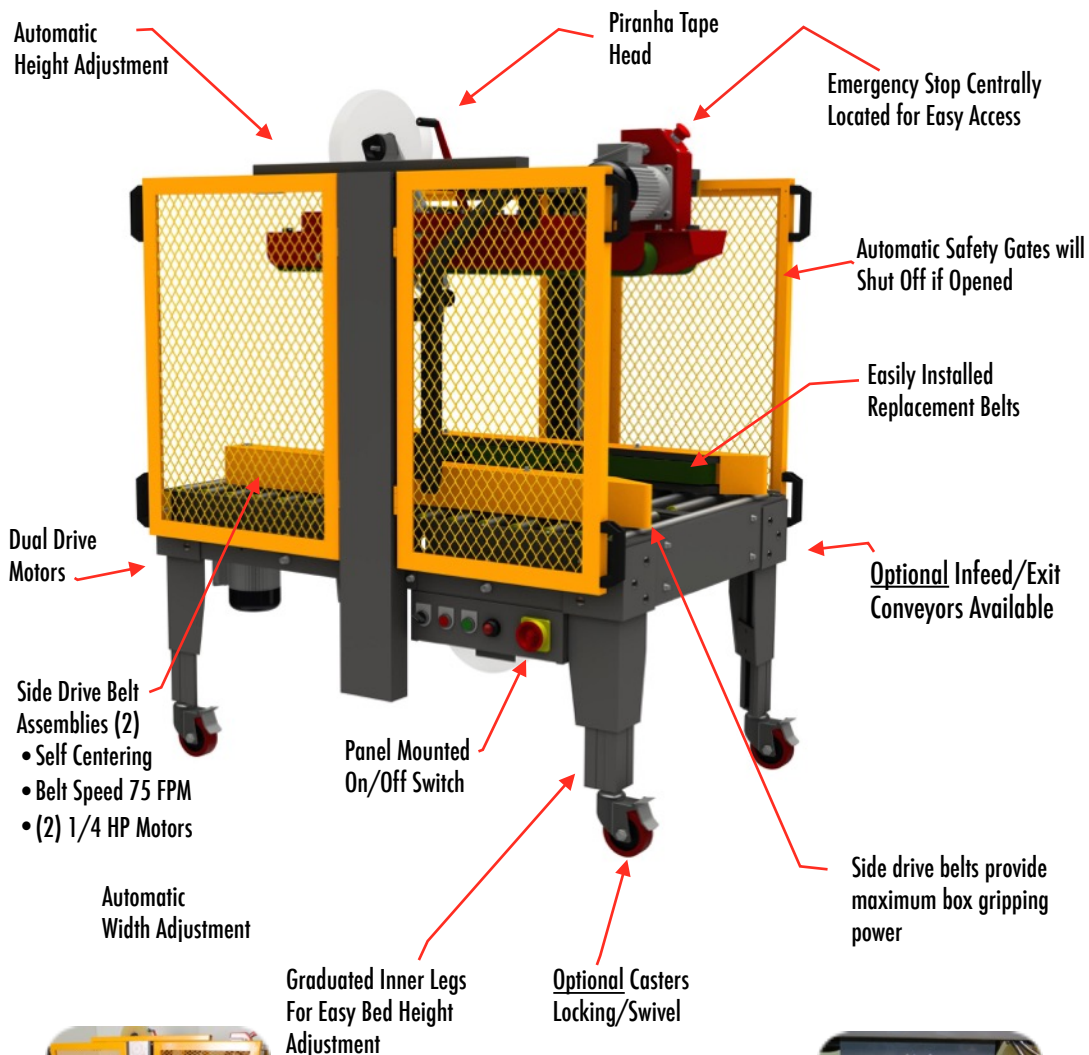
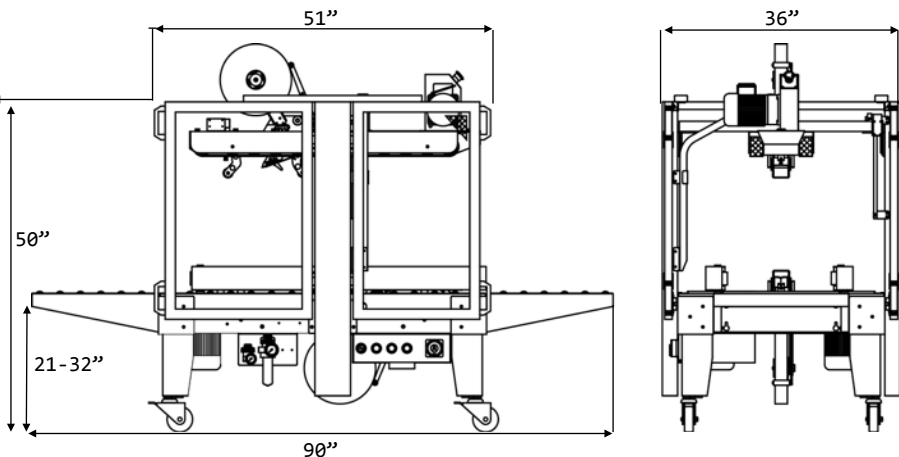

Fully Enclosed Safety Gates Will Shut Machine Off if Opened



Piranha Tape Heads with Optimizer Arm

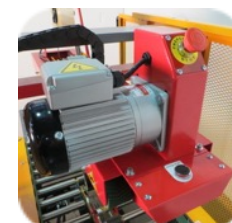

Emergency Stop Switch



Air Required for Pneumatic Operation

mybinding.com
1-800-944-4573