

Foster On-a-Roll Lifter Jumbo - 61577

Product Spec Sheet



Provided by

MyBinding.com

When Image Matters.

Call Us at 1-800-944-4573

Foster

NEW LIFTER OPTIONS

63292
Roll Ramp
Tray



63215
Roller
Platform



ON-A-ROLL LIFTER® POWER JUMBO



With a powerful 12-volt DC motor, the On-a-Roll Lifter® Power Jumbo allows one operator to easily lift and lower rolls as heavy as 990 lbs (450 kg), as wide as 16 feet 5 inches (500 cm), and with diameters as great as 19.6 inches. This motorized lifter securely positions large and heavy rolls while providing a safe, effortless, and efficient solution for handling.



With the push of a button the Power Jumbo easily lifts and lowers.

IMPORTANT FEATURES

- Powerful DC motor easily lifts and lowers rolls, eliminating manual labor
- Power lift reduces roll changeover time
- Pair of heavy-duty swivel casters with easy step-on locking brake
- Reduces on-the-job injuries and enables all workers to move heavy rolls
- User-friendly operation avoids costly and dangerous handling mistakes that damage media
- Rugged construction ensures long lifter life
- Single-person operation saves labor and time

MODEL 61595

Roll Weight Capacity.....	450 kg (990 lbs)
Max. Lift Height.....	150 cm (58.95")
Max. Roll Width	500 cm (16' 5")
Max. Roll Diameter	50 cm (19.6")
Width x Depth.....	120 cm x 77.48 cm (47.24" x 30.51")
Height.....	155.5 cm (61.22")
Weight.....	170 kg (375 lbs)
Bottom Fork Clearance	11 cm (4.33")
Electric.....	12V/60AH DC motor
Battery.....	Maintenance free lead acid battery
Charger	Built-In 110V AC charger
Front Swivel Castors.....	3" ø x 1.81"W
Rear Swivel Castors	5" ø x 1.46"W

2-year warranty on all wheels, hydraulics and media tray.

MyBinding.com
5500 NE Moore Court
Hillsboro, OR 97124

Toll Free: 1-800-944-4573
Local: 503-640-5920



ON-A-ROLL LIFTER® POWER JUMBO SPECIFICATIONS 61595

Use the drawings below and the specifications overleaf to ensure the On-a-Roll Lifter® Power Jumbo is right for your shop.

- THINGS TO CONSIDER:
- Maximum lift height required
 - Maximum and minimum roll diameter
 - Will any obstructions prohibit moving the lifter close to the receiving machine?

Still have questions? Call 800.523.4855

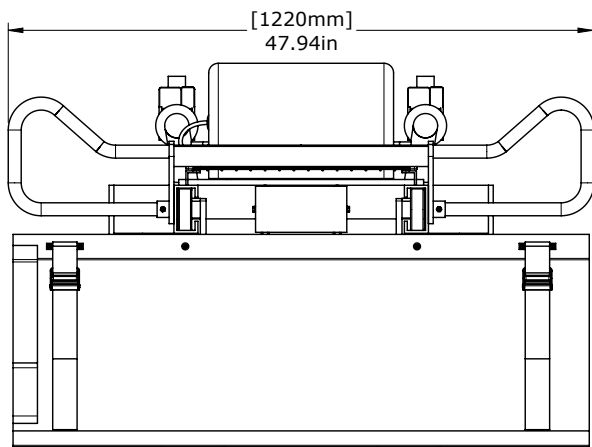

Roll Tray included for easy loading from pallets and handling large diameter, heavy rolls.



63292 Roll Ramp Tray for easy loading from the floor and handling large diameter, heavy rolls.



63215 Roller Platform is designed to allow operators to feed rolls into their machines directly from the lifter.

