

Premier StakCut 724 24" ***Heavy Duty Paper Trimmer***

Instruction Manual



Provided by

MyBinding.com
When Image Matters.

Call Us at 1-800-944-4573

Premier® StakCut Paper Trimmers

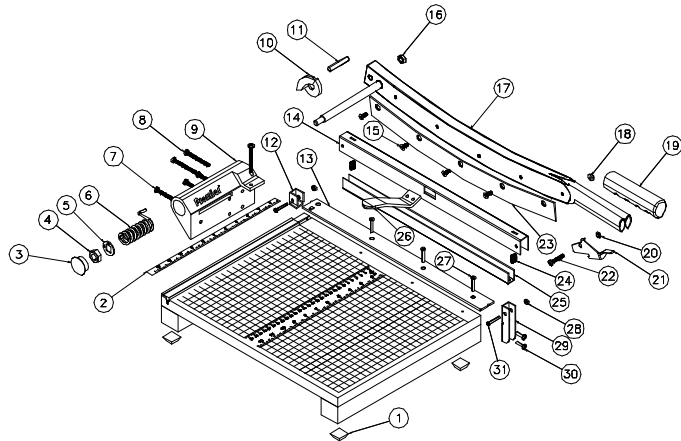

715 PARTS LIST

Part Number	Description	Qty.	Part Number	Description	Qty.	Part Number	Description	Qty.			
1	M-S030021	Rubber Foot	4	12	W-O072167	Clamp Post Bearing	1	23	W-O721515	15" Curved Stack Blade	1
2	M-O017937	715x Ruler	1	13	W-O010515	15" Straight Blade	1	24	M-O721516	Extension Springs	2
3	M-S016012	1 1/8 Hole Plug	1	14	W-O072163	15" Clamp Cover	1	25	W-O072160	15" Clamp Bar	1
4	M-S007026	1/2-13 Hex Lock Nut	1	15	M-S001020	10-32 x 1/2 PHIL UC FH	4	26	W-A715A01	Pin Clamp Handle	1
5	W-O001757	Torque Washer	1	16	M-S007021	5/16-18 Jam Hex Nut	1	27	M-S004061	#8 x 1.25 Trim Hd.	4
6	M-S031053	Large Trimmer Spring	1	17	W-A715A00	715 Handle Assy	1	28	M-S007054	6-32 Hex Keps Nut	2
7	M-S004039	10 X 1.5 PHPHPBS	3	18	M-S007033	Hex Acorn Nut, 10-32	1	29	W-O072168	Clamp Post Front	1
8	M-S004050	10x2 Ph Rd Lo-Root	3	19	M-S043016	1" Hand Grip, Maroon	1	30	M-S004065	#8 x 5/8 PH Pan Hd	2
9	W-A017511	Prem. Lrg. Block	1	20	M-O017642	Latch Spacer	1	31	M-S001058	6-32 x 1 Phil Pan Head	2
10	M-O017654	Block Wear Pad	1	21	W-O017652	Large Safety Latch	1				
11	M-S038006	5/16-18 X 1 3/4 SL. Oval	1	22	M-S001149	10-32 x 1.13 P/PH B/O	1				

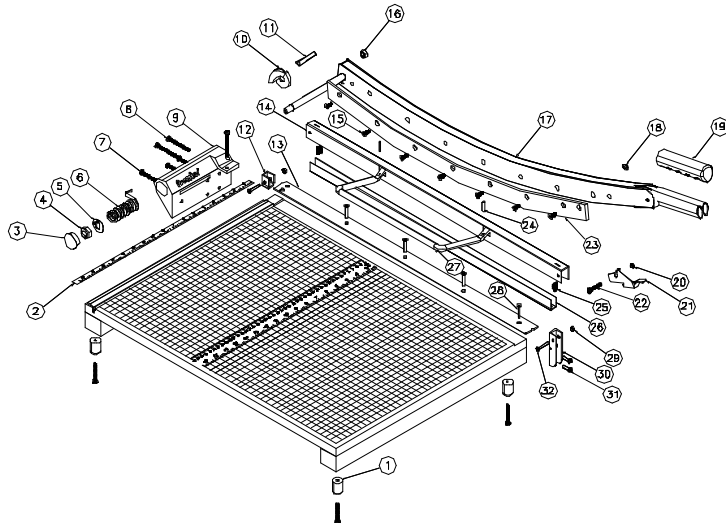
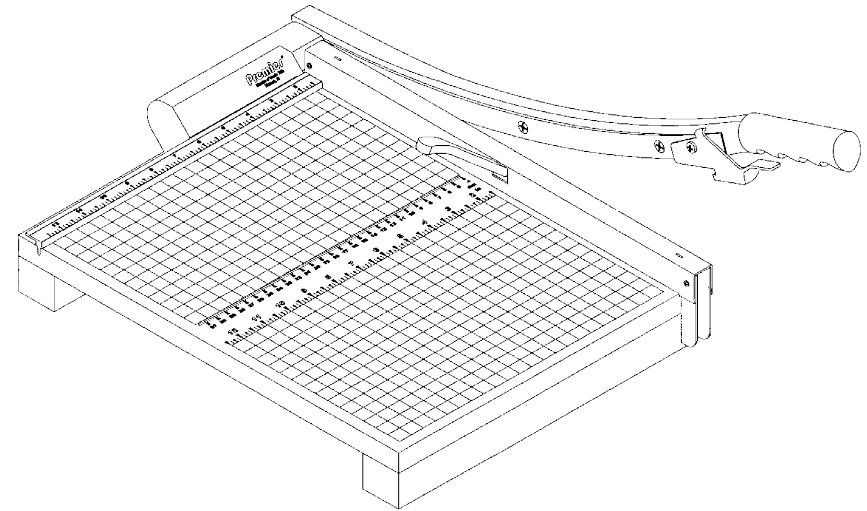

724 PARTS LIST

Part Number	Description	Qty.	Part Number	Description	Qty.	Part Number	Description	Qty.			
1	M-S030002	Rubber Foot w/Recess	4	12	W-O072167	Clamp Post Bearing	1	23	W-O722415	24" Curved Stack Blade	1
2	M-O017957	724 Ruler, .50 x 17.56	1	13	W-O010524	24" Straight Blade	1	24	M-S018002	1/8d x 3/4 Rollpin	2
3	M-S016012	1 1/8 Hole Plug	1	14	W-O072165	24" Clamp Cover	1	25	M-O721516	Extension Springs	2
4	M-S007026	1/2-13 Hex Lock Nut	1	15	M-S001020	10-32 x 1/2 PHIL UC FH	7	26	W-O072162	24" Clamp Bar	1
5	W-O001757	Torque Washer	1	16	M-S007021	5/16-18 Jam Hex Nut	1	27	W-O722418	Clamp Handle	1
6	M-S031053	Large Trimmer Spring	1	17	W-A724A00	724 Handle Assy	1	28	M-S004061	#8 x 1.25 Trim Hd.	5
7	M-S004039	10 x 1.5 PHPHPBS	7	18	M-S007033	Hex Acorn Nut, 10-32	1	29	M-S007054	6-32 Hex Keps Nut	2
8	M-S004050	10x2 Ph Rd Lo-Root	3	19	M-S043016	1" Hand Grip, Maroon	1	30	W-O072168	Clamp Post Front	1
9	W-A017511	Prem. Lrg. Block	1	20	M-O017642	Latch Spacer	1	31	M-S004065	#8 x 5/8 PH Pan Hd	2
10	M-O017654	Block Wear Pad	1	21	W-O017652	Large Safety Latch	1	32	M-S001058	6-32 x 1 Phil Pan Head	2
11	M-S038006	5/16-18 x 1 3/4 SL. Oval	1	22	M-S001149	10-32 x 1.13 P/PH B/O	1				

Key Features and Benefits

- Clamp securely holds stacks for accurate cutting without tearing or shifting
- Heavy-duty 3/4" thick wood base
- Fully-hardened self-sharpening steel blades cut up to 30 sheets
- Accurately cuts paper, matte board, cardboard, film, tissue, and textiles
- Permanent 1/2" grid and dual rulers for proper paper alignment
- Patented automatic blade latch locks with every cutting motion
- Torsion spring counterbalances blade arm
- Non-skid feet

Model Numbers

715 – 15" cutting length

724 – 24" cutting length

MADE IN USA

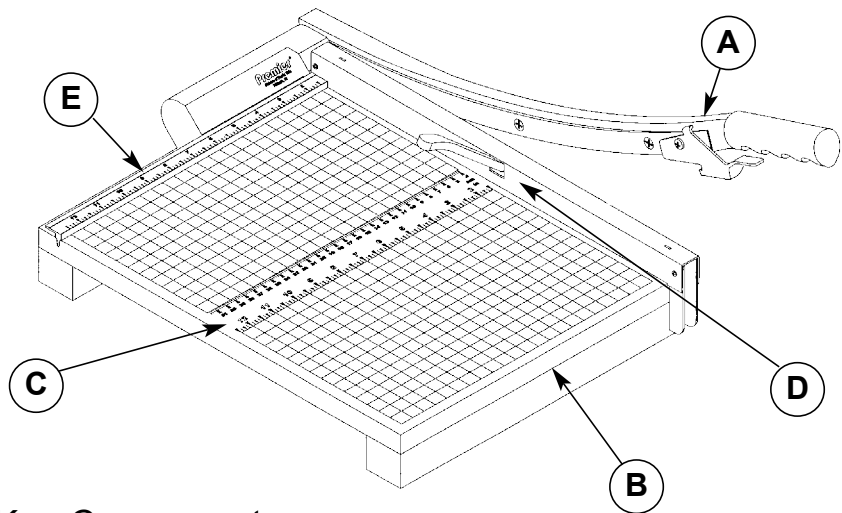

Key Components

- A – Hand Grip/Blade Arm/Blade Latch Assembly
- B – Wood Base
- C – Alignment Ruler
- D – Hold-Down Clamp
- E – Paper Guide Ruler

Assembly Instructions

None – your trimmer is ready for use right out of the box

Automatic Safety Latch

The patented automatic blade latch is a key safety feature of this trimmer. It will lock with every complete cutting stroke, helping to eliminate forgetfulness. Remember to always push the blade arm down completely when you are finished cutting, to ensure that the latch activates. Never remove the latch for any reason.

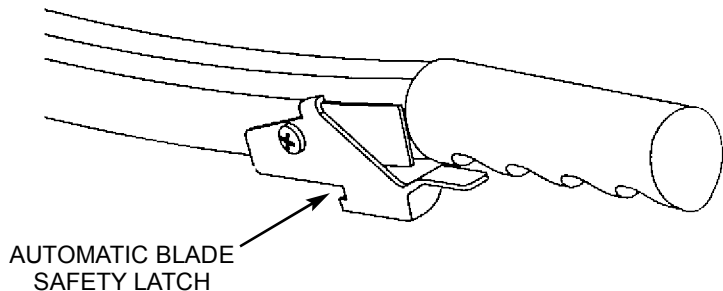

Operating Instructions

1. Place the trimmer on a flat, stable surface
2. Release the blade latch, which is located on the hand grip (A)
3. Lift the blade arm (A) up into cutting position
4. Slide the paper under the clamp (D), pushing the paper up against the paper guide ruler (E), and use the rulers or the 1/2" grid, to align the paper to the proper position.

CAUTION:

Keep hands and fingers behind the clamp (D) at all times, away from the cutting blades

5. While holding the silver clamp handle (D) down with your left hand, pull down the blade arm (A) to cut.
6. Always make sure that the blade arm is completely down and locked when not in use.

Safety Information

- Always ensure that the blade arm is fully pushed down, and that the blade latch is engaged, when not in use
- Never operate the trimmer without the clamp in place
- Always keep clothing, jewelry, watches, and hair away from the cutting blade
- Keep out of the reach of children
- Do not carry the trimmer by the hand grip or the blade arm

For Best Cutting Performance

Use Trim-Ease Blade Lubricant for a smoother cut and to help preserve the life of the cutting blade. To order, send \$4.00 per stick and a self-addressed, stamped envelope to the address below.

Customer Service

Telephone: (260) 563-0641
Fax: (260) 563-4575
Email: info@martinyale.com
Internet: www.martinyale.com
Address: Martin Yale Industries, Inc.
 251 Wedcor Avenue
 Wabash, IN 46992

Visit **www.martinyale.com** for information on office products, including folding machines, punches, and catalog racks.