

***SealerSales CBS-8801
Horizontal Continuous
Band Sealer (Right Feed)***

Product Spec Sheet



Provided by

MyBinding.com

When Image Matters.

Call Us at 1-800-944-4573

Stainless Steel Right Feed CONTINUOUS BAND SEALERS

CBS-880 is suitable for sealing all types of thermoplastic materials and bags. This sealer can be used in a variety of fields such as the food, medical, and cosmetic industries. Can seal 20-30 6" poly bags in one minute. Optional embossing wheel allows operator to include a message on the seal line of the bag.

FEATURES

- Durable stainless steel construction
- Easy to operate – minimal operator training
- Fast warm up time
- Solid state digital temperature controller to maintain seal bars at proper temperature for consistent seal quality
- Fully adjustable conveyor (conveyor height and depth in relation to seal bars can be adjusted)
- Motorized rubber conveyor for speed control
- Knurled pressure rolls with variable pressure adjustment
- Sealing method – constant/direct heat accompanied with a pair each of cooling and heating blocks
- Unit feeds right to left (For left to right feed, see FR-770)
- Can easily be converted to vertical configuration using an optional conversion kit (see picture below)
- Spare parts includes: PC Board, PTFE belt, wheel belt, and standard type set. Additional typesets can be purchased.

OPTIONAL FEATURES

- Optional embossing wheel to emboss on seal line without ink
- 2-line embossing wheel
- Stainless steel stand for both horizontal and vertical models
- 15mm seal width
- Digital counter to keep track of sealed packages

SPECIFICATIONS	
POWER	110V / 60Hz
MOTOR POWER	50W
SEALING SPEED	0-472 INCHES/MINUTE
SEAL WIDTH	8MM
TEMPERATURE RANGE	0-300°C
CONVEYOR SIZE	38" X 7"
SINGLE CONVEYOR LOAD	2.2LBS
MAX CONVEYOR LOAD	6.6LBS
BAG SIZE (FILLED)-VERTICAL	MINIMUM - 6" MAXIMUM - 12"
CHARACTER SIZE	3 X 4 X 9MM / 18PT
OPTIONAL EMBOSSING	1 LINE EMBOSSING (2 LINES AVAILABLE) 3 SECTIONS W/ 15 CHARACTERS/LINE
DIMENSIONS	33" X 17" X 13"
WEIGHT	66LBS



CBS-880



CBS-880II

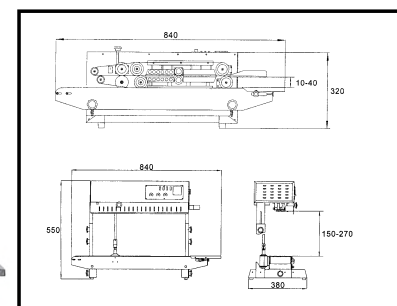

Measurements in mm

Update 07/01/16.

Do not reproduce without permission.

Stainless Steel Right Feed

CONTINUOUS BAND SEALERS

