

SealerSales FRS-1120W
Free-Standing Horizontal Color Ribbon
Printing Continuous Band Sealer

Product Spec Sheet



Provided by

MyBinding.com
When Image Matters.

Call Us at 1-800-944-4573

Free Standing Color Ribbon CONTINUOUS BAND SEALERS

FRS-1120W is designed to quickly and efficiently seal any thermoplastic material including PE, PPE, stand up pouches, gusseted bags, and moisture barrier bags. This sealer can also be used in a wide array of fields such as: food, medical, and cosmetics industries. The FRS-1120W is equipped with an imprinter for color ribbon printing on your package while sealing. Color ribbon printing provides a stronger adhesion print than dry ink coding and works best for humid environments.

FEATURES

- Durable stainless steel construction
- Tilting seal head which allows machine to tilt up to 30 degrees; suitable for liquids!
- Easy to operate – minimal operator training
- Fast warm up time
- Solid state digital temperature controller to maintain seal bars at proper temperature for consistent seal quality
- Fully adjustable conveyor (conveyor height and depth in relation to seal bars can be adjusted)
- Color ribbon allows for printing above the seal line
- Motorized rubber conveyor for speed control
- Knurled pressure rolls with variable pressure adjustment
- Sealing method – constant/direct heat accompanied with a pair each of cooling and heating blocks
- Unit feeds right to left
- Spare parts includes: PC Board, PTFE belt, wheel belt, fuse, motor brush, heating element, and type set

SPECIFICATIONS	
POWER	110V / 60Hz
MOTOR POWER	100W
SEALING SPEED	0-394 INCHES/MINUTE
SEAL WIDTH	8MM
TEMPERATURE RANGE	0-300°C
SEALING POWER	300 X 2
CONVEYOR SIZE	43" x 8"
MAX CONVEYOR LOAD	16.5LBS
CHARACTER SIZE	2 x 4 x 15mm / Ribbon – 30mm
PRINTING HEATING POWER (W)	50 x 2
PRINTING OPTIONS	11 CHARACTERS/LINE 2 LINES
DIMENSIONS	43" x 24" x 41"
WEIGHT	187LBS / 282 LBS (GW)

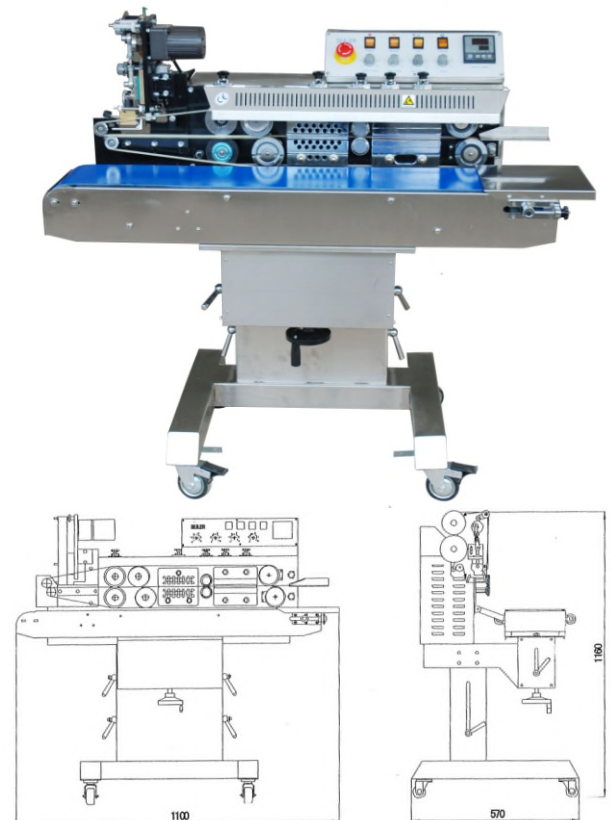

Measurements in mm