

AKILES RUBICOIL

Instruction Manual



Provided By

MyBinding.com®
When Image Matters.

RubiCoil OPERATION MANUAL

INTRODUCTION

CONGRATULATIONS ON THE PURCHASE OF YOUR NEW RubiCoil, A MODERN, PRACTICAL AND RELIABLE PUNCH AND BINDING EQUIPMENT. YOUR RubiCoil WAS DESIGNED WITH PREMIUM QUALITY COMPONENTS TO GUARANTEE AN EFFORTLESS AND EASY BIND, AS WELL AS MANY YEARS OF TROUBLE- FREE SERVICE.

IMPORTANT

WE RECOMMEND THAT YOU TAKE A FEW MINUTES TO FAMILIARIZE YOURSELF WITH THE FUNCTIONS OF YOUR NEW RubiCoil. YOU WILL FIND OUT THAT WITH JUST A LITTLE PRACTICE, ANYONE CAN ACHIEVE PROFESSIONAL RESULTS.

FEATURES

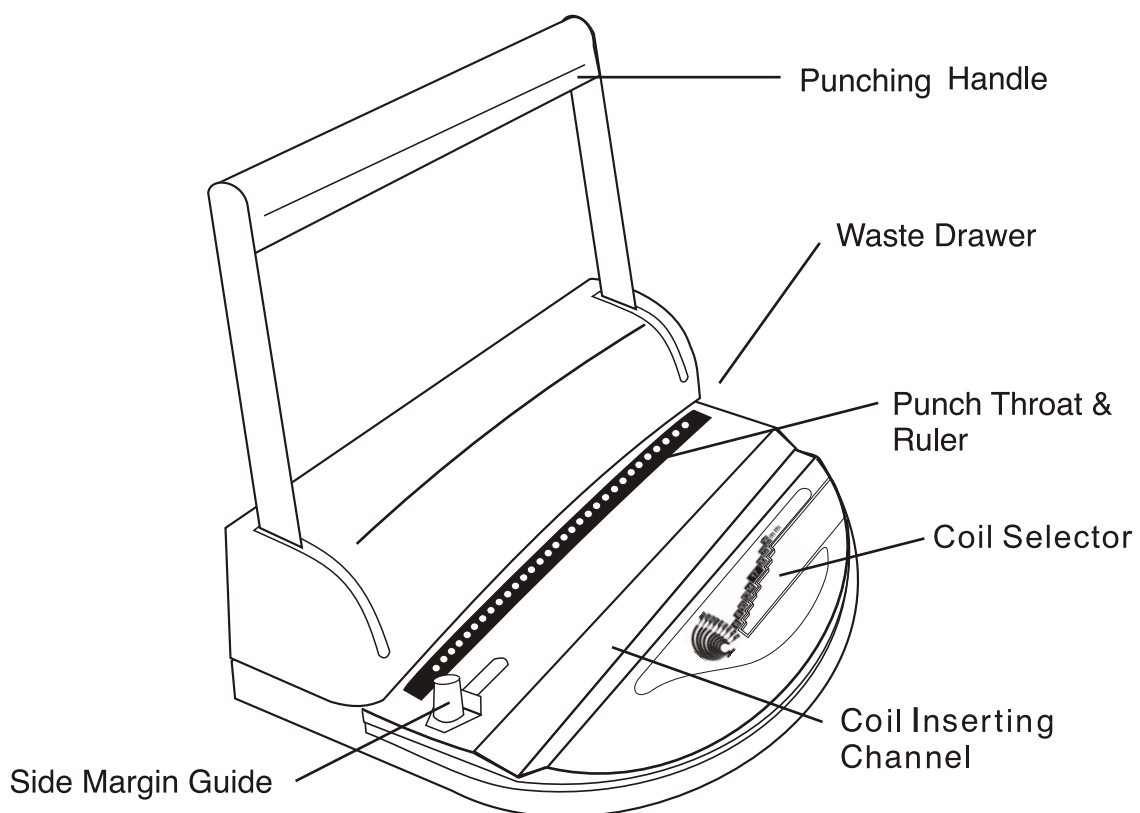

WARRANTY

YOUR RubiCoil HAS A WARRANTY OF ONE YEAR, FROM ITS PURCHASE DATE. IN THE EVENT OF A MANUFACTURER'S DEFECT, YOUR DISTRIBUTOR (AT OPTION) WILL REPAIR OR REPLACE IT. IMPORTANT: THIS WARRANTY DOES NOT COVER DAMAGES DUE TO IMPROPER USE OR MISTREATMENT OF THE UNIT, INCLUDING ANY EXTRAORDINARY EVENT LEADING TO THE DAMAGE OF THE MACHINE, WHETHER IT IS REVERSIBLE OR NOT.

IF THE RubiCoil IS NOT OPERATING PROPERLY, FIRST FOLLOW THE CORRECTIVE ACTIONS PROVIDED. IF THE PROBLEM PERSISTS, PLEASE CONTACT YOUR DEALER FOR FURTHER INSTRUCTIONS. PLEASE HAVE YOUR MACHINE'S SERIAL NUMBER AND THE PURCHASE DATE READY. IF THE MACHINE MUST BE RETURNED TO YOUR DISTRIBUTOR, IT IS YOUR RESPONSIBILITY TO PROPERLY PACK AND SHIP IT, AS ANY DAMAGES INCURRED DURING ITS TRANSPORTATION IS NOT COVERED BY OUR WARRANTY POLICY.

ASSEMBLY

Your **Rubycoil** comes fully assembled. Simply place it on top of a sturdy work table and you are ready to work.

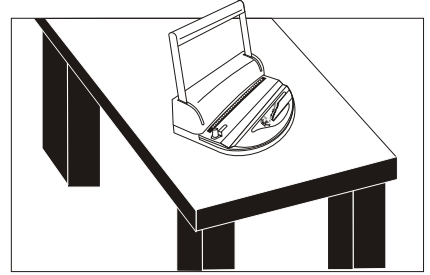

PUNCHING

1. Move (align) Side Margin Guide to proper sheet & cover size. [See Picture 1.](#)
2. Insert sheets and pull handle forward to punch. [See Picture 2.](#)
3. Return Punch handle to its upright position. [See Picture 3.](#)
4. Repeat steps two and three as needed.

TIPS:

- a) Maximum single punching: 10 sheets of 20 lbs. paper
- b) Comfortable single punching: 8-10 sheets of 20 lbs. paper.

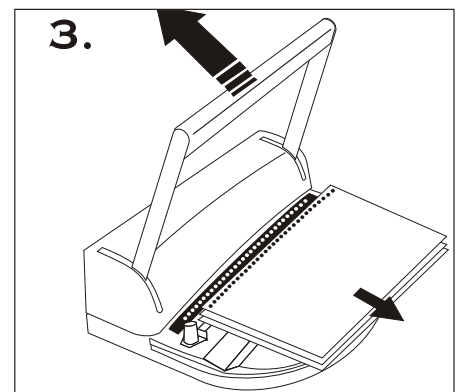
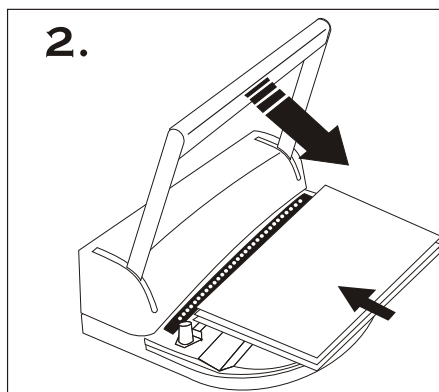
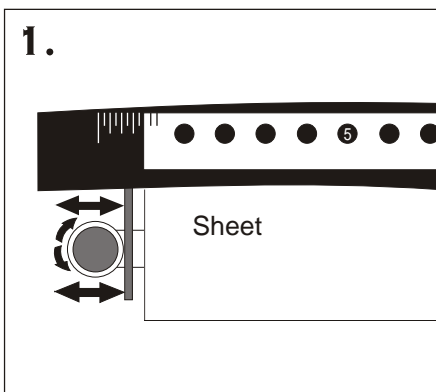

COIL INSERTING (BINDING)

1. Insert coil into first three or four holes. [See picture 1](#)
2. Place your punched document onto Coil Inserting Table and finish inserting coil by sliding hand. [See picture 2](#)
- 3 Use a set of pliers to cut-off any excess coil and bend. Make sure you bend-in both coil ends.
This procedure will avoid document from unbinding itself. [See picture 3](#)

