

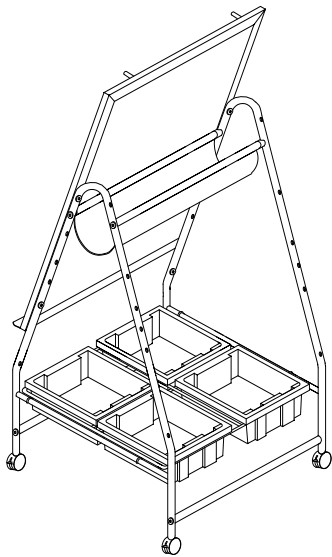

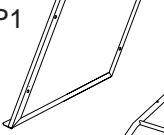

# 763 Storage Wheasel Markerboard

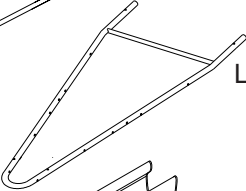
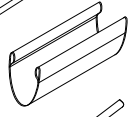
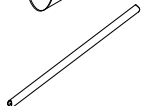
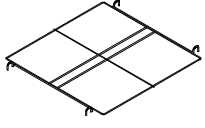
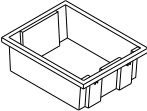

## Parts List

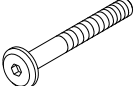
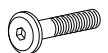
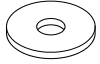
P1		Board	1 EA
P2		Leg	2 EA
P3		Nylon Shelf	1 EA
P4		Crossbrace	4 EA
P5		Wire Rack	1 EA
P6		Storage Tub	4 EA

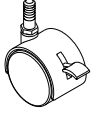
## Hardware List

A		Screw M6 X 46mm	8 EA
A1		Screw M6 X 20mm	4 EA
B		Flat Washer 22mm	4 EA
C		Interior Threaded Post M6 X 18mm	4 EA
E		2" Locking Caster	4 EA
F		Allen Wrench	2 EA
G		Caster Wrench	1 EA

**1** Insert 2 Crossbraces (P4) Through Nylon Shelf (P3) as shown

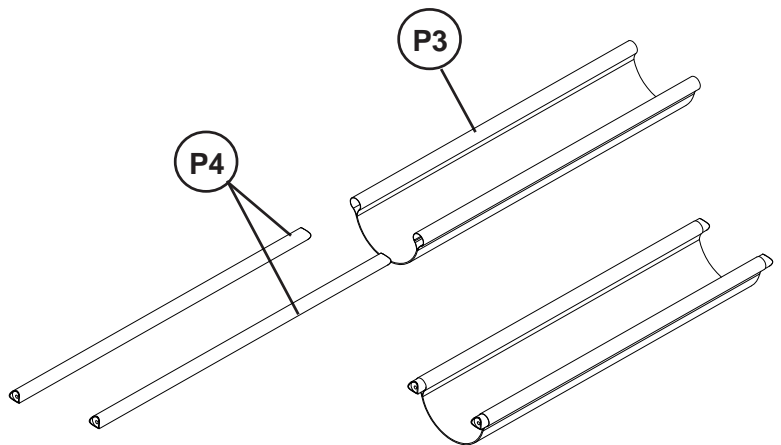

**2** Attach 4 Crossbraces (P4) to the Leg Assemblies (P2) using eight Screws (A).

**3** Use Allen Wrench (F) to tighten Screws.

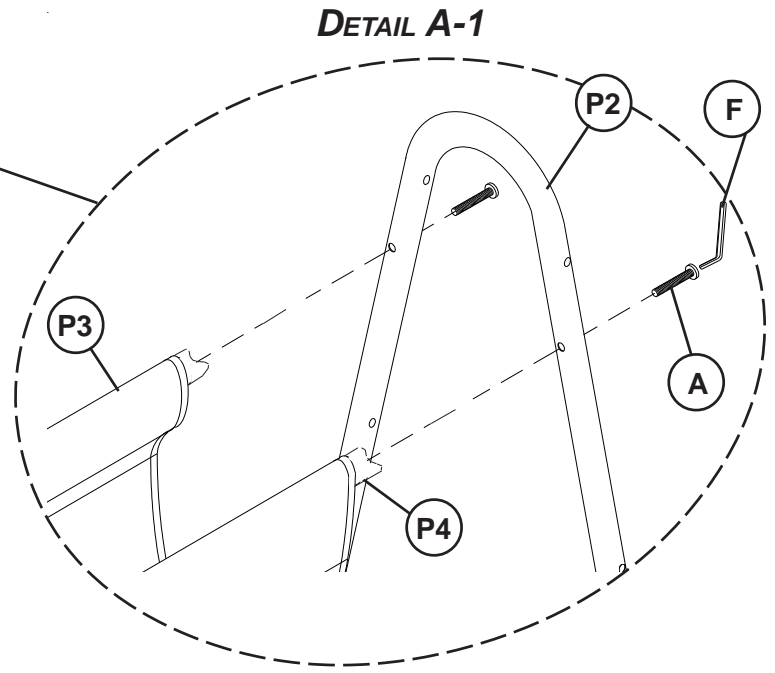
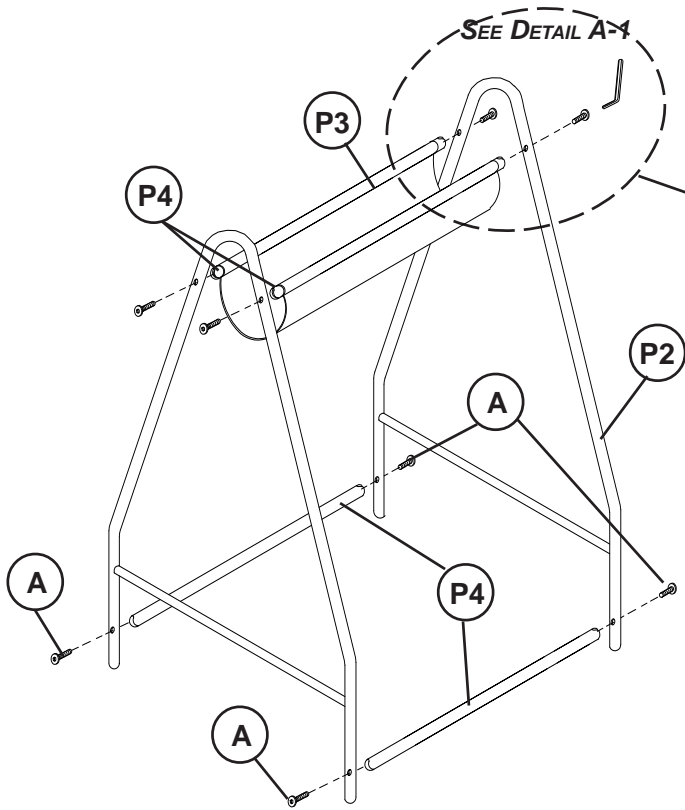

**4** Install 4 Locking Casters (E).  
Use Caster Wrench (G) to tighten casters.

**5** Attach Markerboard (P1).

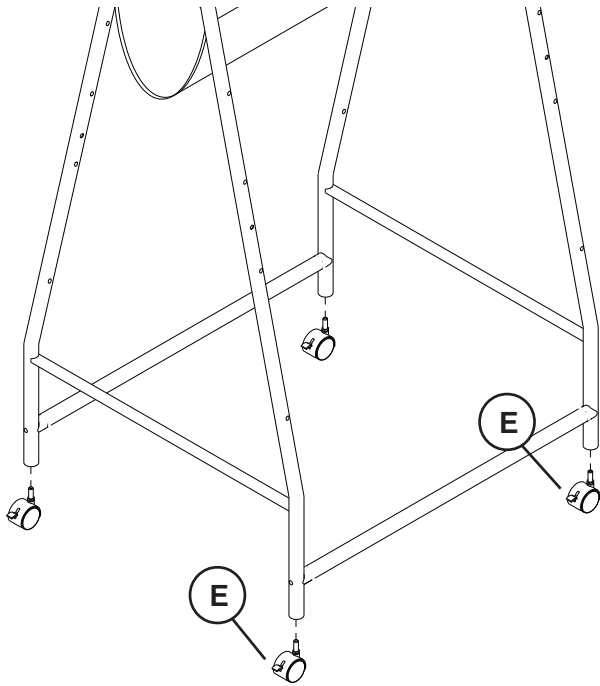

*Tighten screws using Allen Wrench (F).*

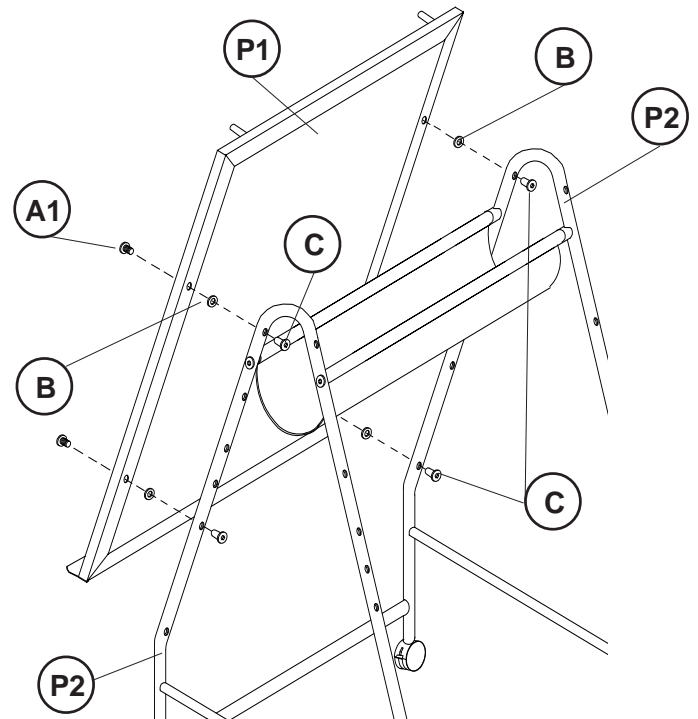

6 Attach Wire Rack (P5).

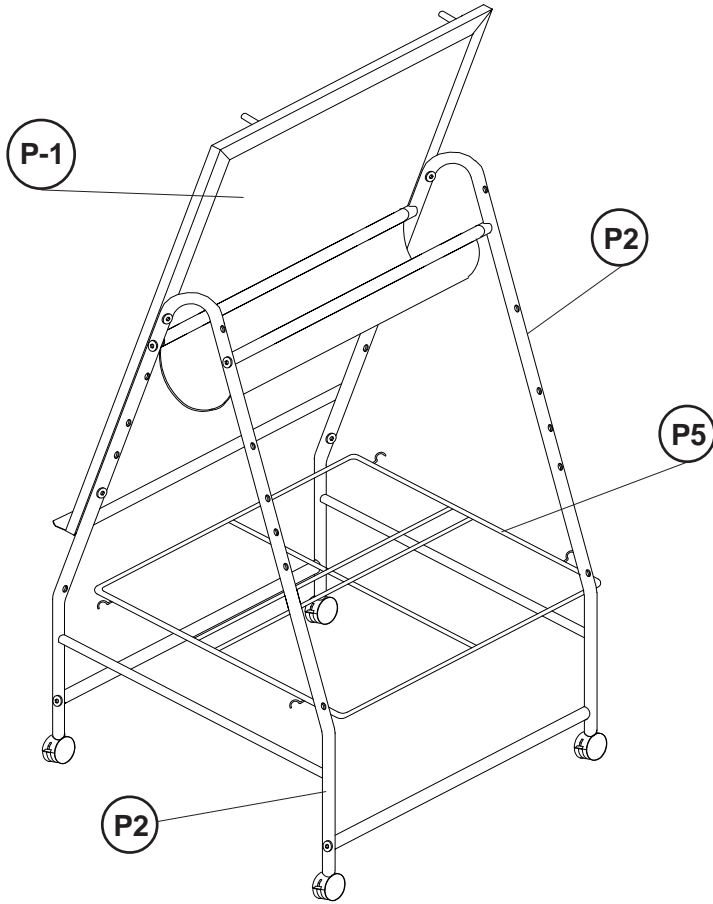

7 Insert 4 StorageTubs (P6).

