

Best-Rite Expandable Nest Easel (2-Sided Dura-Rite Whiteboard)

Instruction Manual



Provided by

MyBinding.com

When Image Matters.

Call Us at 1-800-944-4573



Expanding Nest Easel

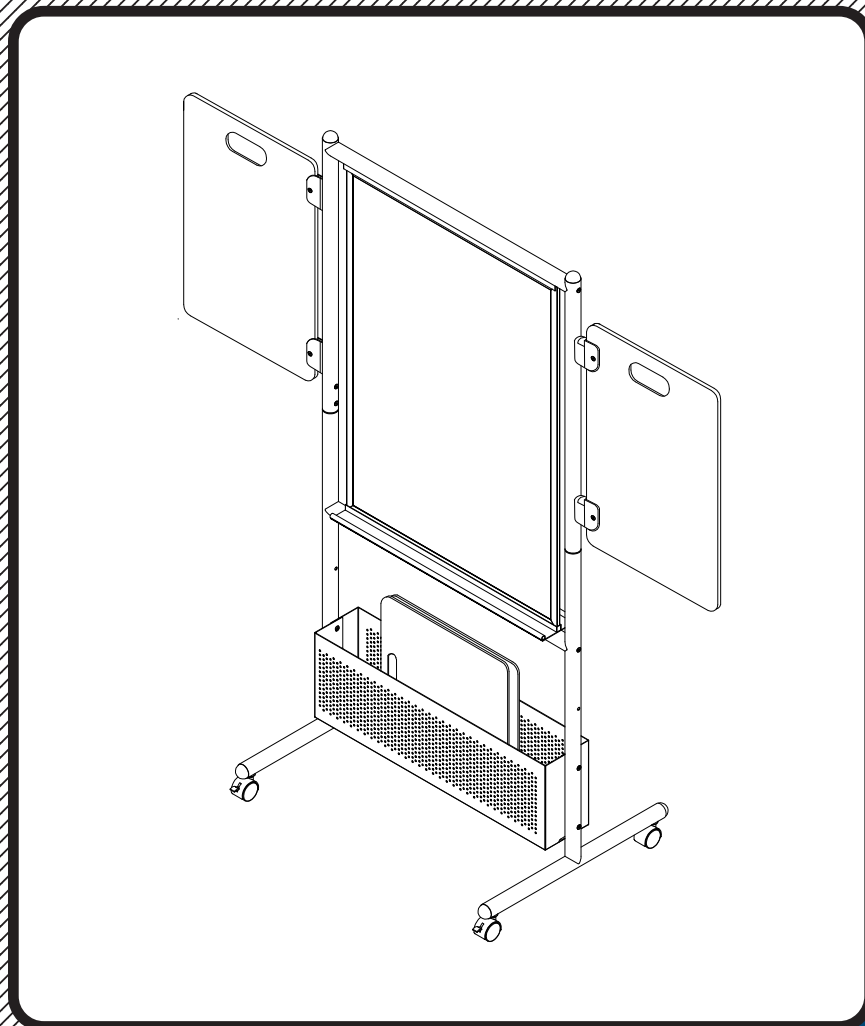





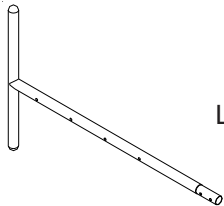
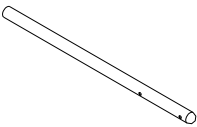
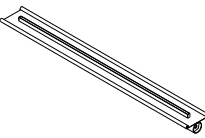
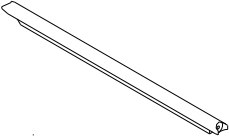
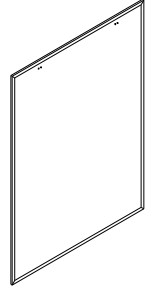
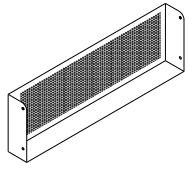
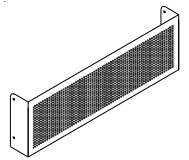
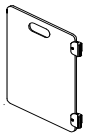





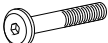

Assembly Instructions

Expanding Nest Easel

Part	Drawing	Description	Qty
P-1		Lower Leg	2 EA
P-2		Upper Leg	2 EA
P-3		Middle Tray	1 EA
P-4		Top Support	1 EA
P-5		Markerboard	1 EA
P-6		Bookrack-Back	1 EA
P-7		Bookrack-Front	1 EA
P-8		Hanging Panel	4 EA

Hardware List

A		9/16" Socket Screw	4 EA
A1		1-3/8" Socket Screw	4 EA
B		2-3/8" Socket Screw	4 EA
C		Interior Threaded Post	4 EA
D		2" Locking Caster (for front)	2 EA
E		2" Caster (for Back)	2 EA
F		Plastic Chart Support	4 EA
G		Allen Wrench	1 EA
H		Caster Wrench	1 EA
I		Plastic Receiver	4 EA
J		Phillips Screw-Short	4 EA
K		Phillips Screw-Long	4 EA

Should you require assistance during assembly, please call our Customer Service Department Monday - Friday 8 a.m. - 5 p.m. Central Standard Time Toll-Free Customer Service 1-800-749-2258

Nest Easel Assembly Diagram

Illustration # 1

READ THROUGH INSTRUCTIONS FROM BEGINNING TO END BEFORE STARTING TO ASSEMBLE UNIT.

To Assemble:

1. Identify and Separate all the Parts and Hardware.
2. Attach Middle Tray (P-3) to 2 Lower Legs (P-1) at desired height using 2 Socket Screws (B) as shown in illustration # 1.
(Finger tighten only)

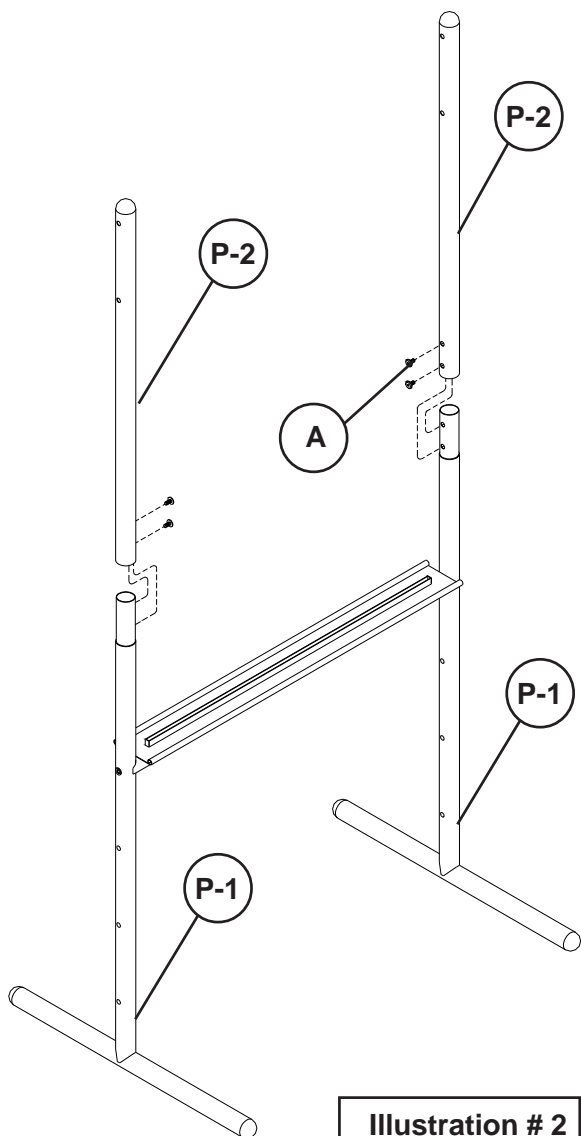
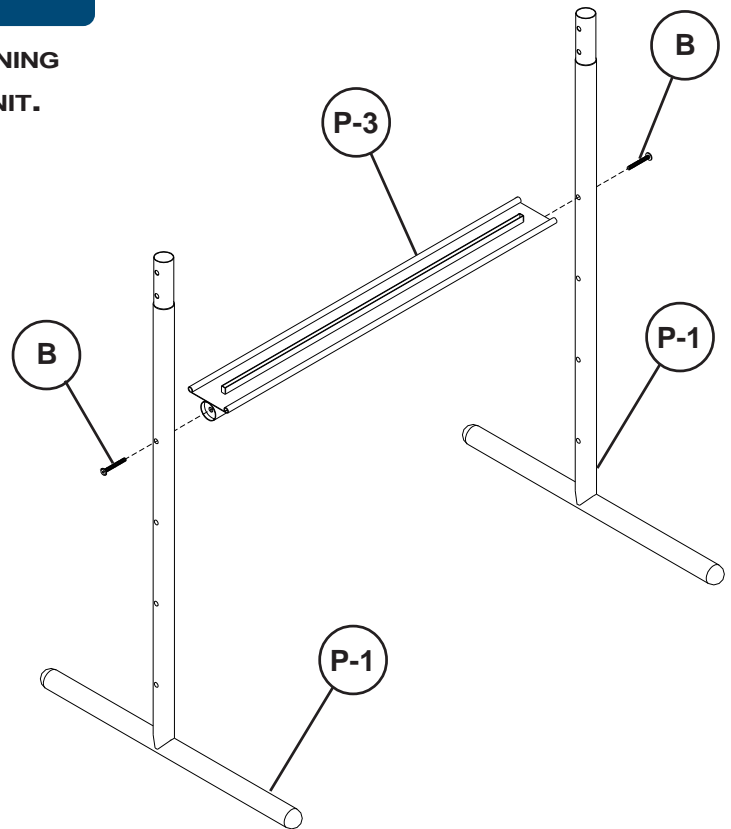

Illustration # 2

3. Attach 2 each Upper Legs (P-2) to the 2 each Lower Legs (P-1) using 4 Socket Screws (A) as shown in illustration # 2.
(Finger tighten only)

Missing Parts or UPS Damaged Parts
For Your Convenience you can
EMAIL us at
support@moorecoinc.com
24HOURS 7 DAYS A WEEK

4. Insert Markerboard (P-5) into Middle Tray (P-3) as shown in illustration # 3.

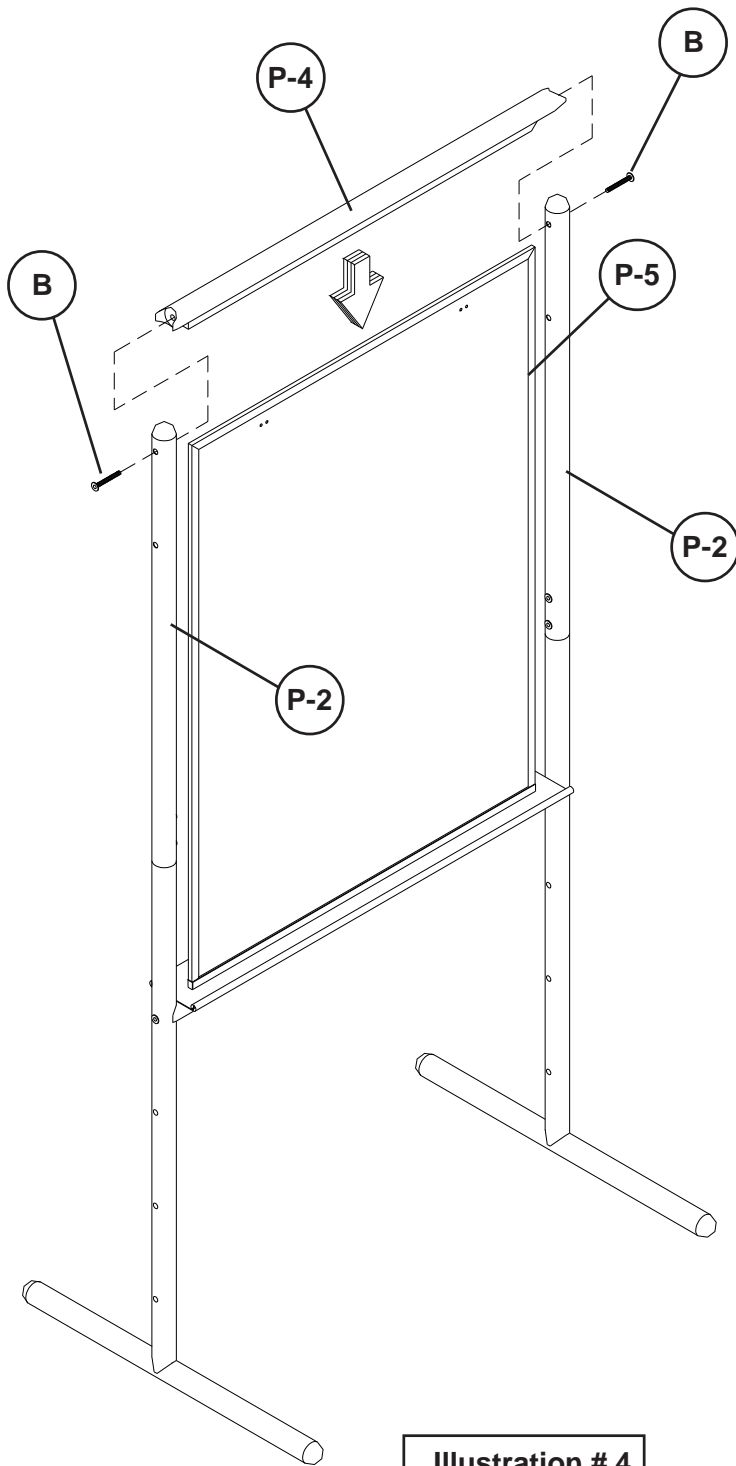
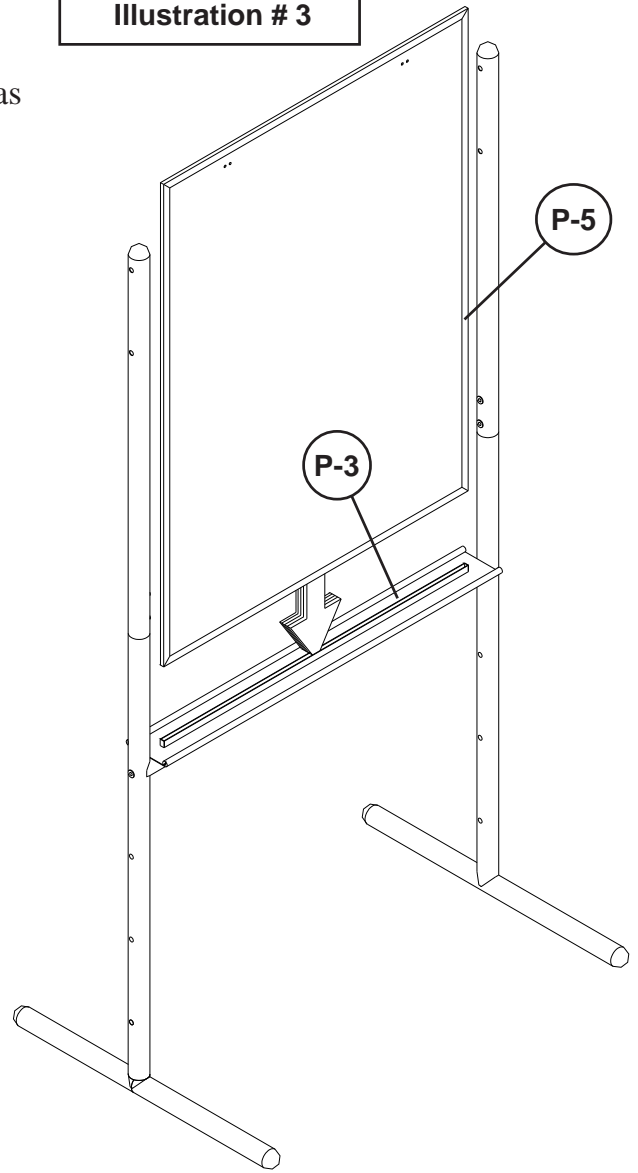

Illustration # 4

Illustration # 3



5. Slide Top Support (P-4) over Markerboard (P-5) and secure to the 2 Upper Legs(P-2) using 2 each Socket Screws(B) as shown in illustration # 4. (**Finger tighten only**)

Do not use unless all screws are tight. At least every six months, check all screws to be sure they are tight. If parts are missing, broken, damaged, or worn, stop use of the product until repairs are made by your dealer using factory authorized parts.

6. Attach Book Rack Front Panel (P-7) and Book Rack Back Panel (P-6) to the 2 Lower Leg Frames (P-1) using 4 Socket Screws (A1) and 4 Interior Threaded Posts (C) as shown in illustration # 5.
7. Attach 2 Locking Casters (D) in the front and 2 Casters (E) in the back of the unit as shown in illustration # 5.
Tighten the Casters using Caster Wrench (G).
(Tighten all Screws at this time)
8. Peel the paper from the back of adhesive pad on Plastic Chart Support (F).
(See Illustration # 6-A)

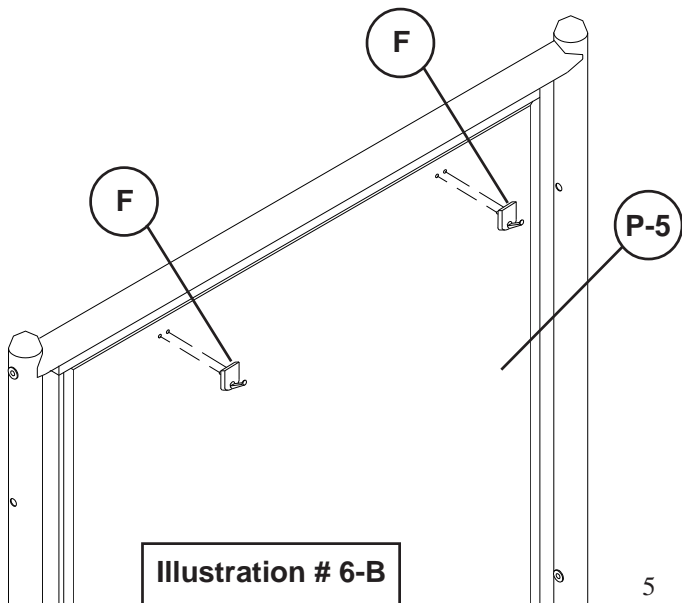
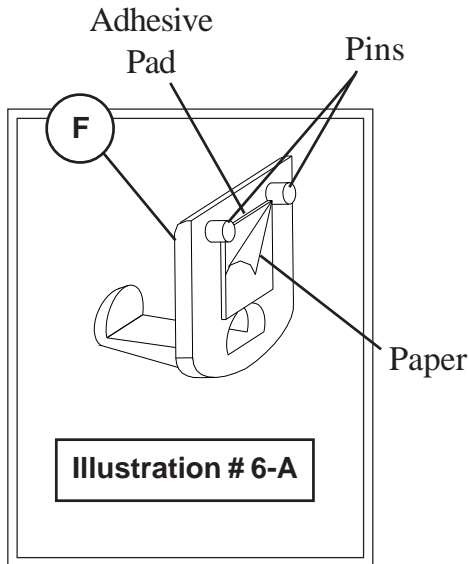
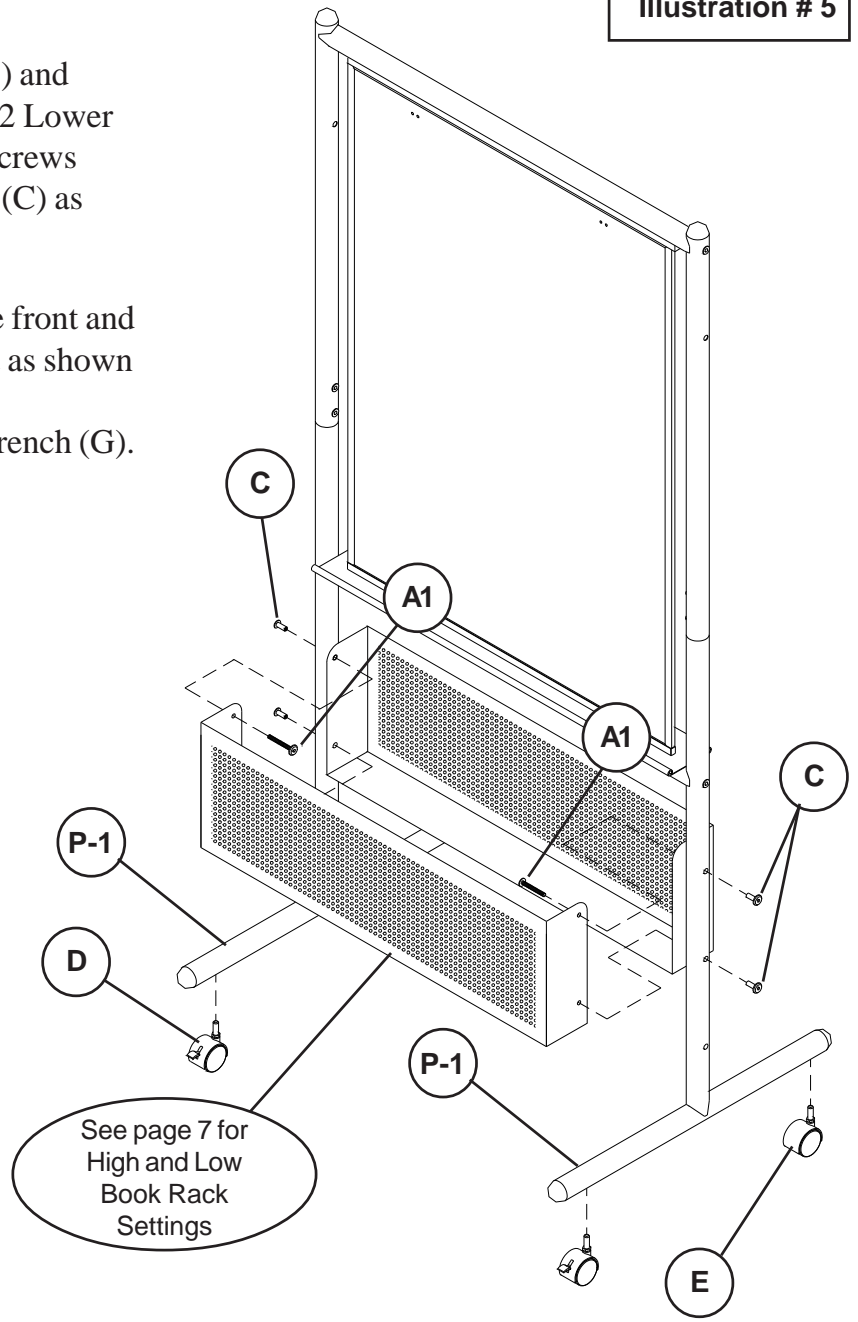

9. Attach 2 Plastic Chart Supports on each side of board: Insert 2 pins on back side of Chart Support (F) through holes in markerboard (P-5) as shown in illustration # 6-B.
10. Press Plastic Chart Support (F) firmly to the Markerboard surface.

11.) Attach four of the Plastic Receivers (I) to each Upper Leg (P2) using one Phillips Screw-Short (J) in the top hole and one Phillips Screw-Long (K) in the bottom in the locations shown in illustration #7.

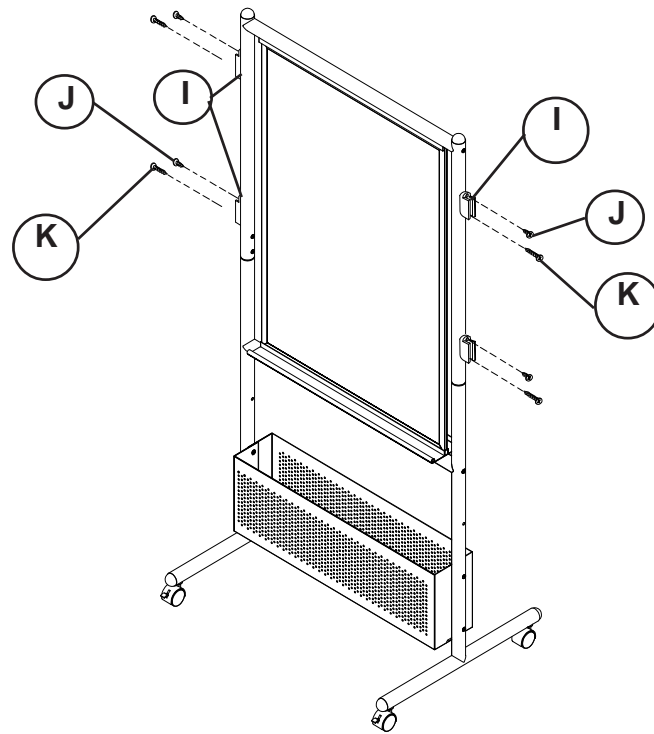

Illustration # 7

12.) Insert a Hanging Panel (P8) into the Plastic Receivers (I) on each side tube as shown in illustration #8. Place the other two Hanging Panels in the bottom Book Storage.

