

Duplo DC-445 Creaser

Instruction Manual



Provided By

MyBinding.com®
When Image Matters.

DuCreaser DC-445 Instruction Manual

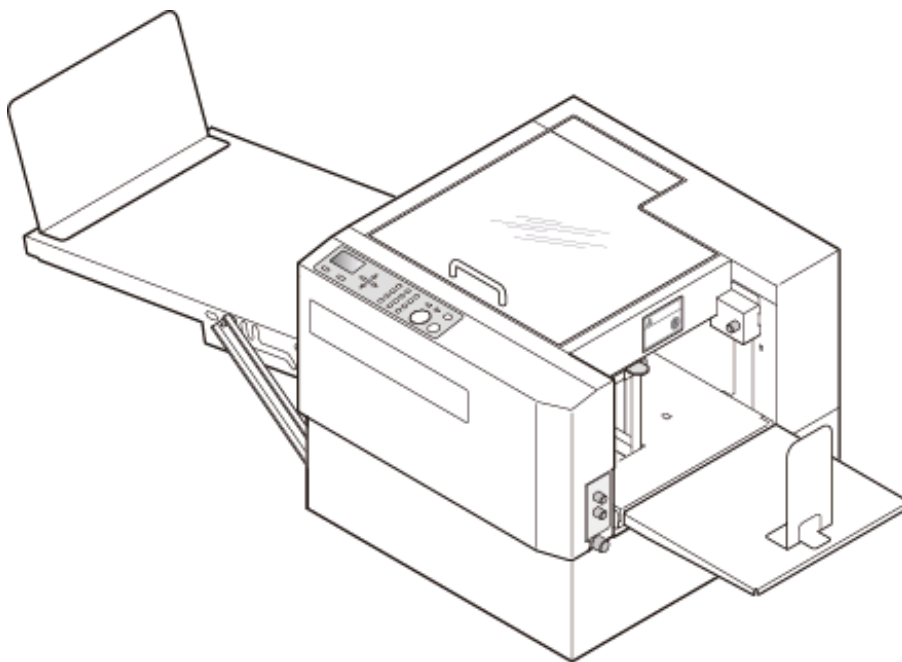

Correct operation and periodic maintenance are essential for ensuring safe use of this machine. Thoroughly read this manual before using this machine.

Duplo



MyBinding.com
When Image Matters.



Disposal of Old Electrical & Electronic Equipment

This symbol (the symbol of the crossed out wheeled bin) indicates that in European countries this product should not be disposed of as household waste.

Please recycle where facilities exist by checking with your local authority or supplier for recycling advice.

By ensuring this product is disposed of correctly through proper treatment, recovery and recycling, you will help prevent potential negative effects on the environment and human health.

En



Entsorgung von alten elektrischen und elektronischen Ausrüstungsteilen

Dieses Symbol (das Symbol mit dem durchgekreuzten fahrbaren Müllbehälter) zeigt an, dass dieses Produkt in europäischen Ländern nicht als Haushaltsmüll entsorgt werden darf. Bitte informieren Sie sich bei Ihren örtlichen Behörden oder bei Ihrem Händler hinsichtlich einer Empfehlung für die Entsorgung und führen Sie die betreffenden Teile dort, wo solche Einrichtungen vorhanden sind, einem Recycling-Prozess zu.

Indem sie sicherstellen, dass das betreffende Produkt durch richtige Behandlung, Rückführung und Recycling entsorgt wird, tragen Sie dazu bei, möglichen negativen Auswirkungen auf die Umwelt und die menschliche Gesundheit vorzubeugen.

Ge



Elimination du matériel électronique et électrique usagé

Ce symbole (une poubelle marquée d'une croix) indique que dans les pays européens, ce produit ne doit pas être éliminé comme des ordures ménagères.

Recyclez-le dans les sites adaptés qui vous seront indiqués par les autorités locales ou renseignez-vous auprès de votre fournisseur.

En veillant à ce que ce produit soit éliminé correctement avec un traitement, une collecte et un recyclage adaptés, vous contribuez à éviter son action nocive potentielle sur l'environnement et la santé humaine.

Fr



Smaltimento di attrezzature elettriche ed elettroniche consumate

Questo simbolo (il simbolo della pattumiera con rotelle barrata) indica che nei paesi europei questo prodotto non deve essere buttato nei rifiuti domestici.

Per favore smaltire in luogo adetto al riciclo, dove esistente, chiedendo informazioni alle autorità locali o a chi fornisce consulenza a proposito.

Garantendo uno smaltimento adeguato di questo prodotto (trattamento, recupero e riciclo corretto), aiuterete a prevenire effetti negativi sull'ambiente e sulla salute dell'uomo.

It



Eliminación de residuos de aparatos eléctricos y electrónicos

Este símbolo (un cubo de basura tachado) indica que en los países europeos este producto no deberá eliminarse como si se tratara de un residuo doméstico. Solicite asesoramiento sobre reciclaje a las autoridades locales o a su distribuidor, y siga la normativa en materia de gestión medioambiental y reciclaje de este tipo de residuos.

Si toma las medidas pertinentes para que este producto se elimine mediante un tratamiento, recuperación y reciclaje adecuados, contribuirá a evitar posibles efectos negativos en el medio ambiente y la salud humana.

Sp

Complies with the provisions defined by the regulations listed below.

EC Low Voltage Directive
(73/23/EEC)

EC Electromagnetic
Compatibility Directive
(89/336/EEC)

▣ Introduction

Thank you for your purchase of the DC-445 (DuCreaser). To ensure safe and efficient use, read and thoroughly understand this manual before using this machine. After using this manual, be sure to keep it in a handy place to reference.

PLEASE NOTE

In the interest of upgrading our products, specifications and other data given in this manual are subject to change without notice. If the manual contains anything that you do not understand, contact the manufacturer for clarification.



Notes on Safety (Please Read and Observe)

Safety Precautions

Various symbols and pictures are used in this manual and on the stickers affixed to the machine. These symbols and pictures provide warnings and instructions to prevent danger to you or other personnel, and to prevent damage to office property.

The meanings of these symbols and pictures are explained below.

WARNING

Indicate a high degree of potential danger. If the warning is ignored, death or serious injury may result.

CAUTION

Indicate a medium degree of potential danger. If the caution is ignored, medium injury or damaged to property may result.

<Examples of Pictorial Symbols>







- A circle with a line through it indicates a prohibited action. The particular act prohibited is indicated by a picture inside the circle. (In the example shown here, the prohibited act is disassembly.)



- A black disc indicates an instruction, or sometimes a prohibited action. The instruction itself is indicated by pictorial symbols drawn in white on the disc. (In the example shown here, the instruction is 'Remove the plug from the outlet.')

● Precautions for use

 WARNING	
	<ul style="list-style-type: none">● If the machine is used after foreign matter (metal fragments, water, or liquid) has entered the machine, this may result in fire or electric shock. → Turn the main unit's power switch OFF, and then remove the power plug from the outlet. Contact the sales distributor.
	<ul style="list-style-type: none">● If the machine is used after heat, smoke, strange smell, or other abnormality is detected, this may result in fire or electric shock. → Turn the main unit's power switch OFF, and then remove the power plug from the outlet. Contact the sales distributor.
	<ul style="list-style-type: none">● Do not insert or drop metal, flammable material, or other matter through the ventilation holes into the machine interior. → Doing so may result in fire or electric shock.
	<ul style="list-style-type: none">● Do not place flower vases, flowerpots, cups, or water containers (including metal containers) on top of the machine. → Fire or electric shock may result if liquid spills inside the machine.

CAUTION



- Some paper may cause paper dust in the machine. Keep clean the machine and sufficient ventilation.

•Caution for Grounding (Be sure to use the supplied power cord)

WARNING



- Use only the power cord that is provided among the accessories. Insert the power cord plug firmly into the socket, so that proper electrical contact is effected.
 - Use of any other power cord could result in imperfect grounding. If grounding is imperfect and electrical leakage occurs, fire or electric shock could result.

•Caution for Power Supply and Power Cord

WARNING



- Do not use a source voltage other than that specified. Do not connect two or more loads to a single outlet.
 - Doing so may result in fire or electric shock.



- Do not remove or insert the power plug with wet hands.
 - Doing so may result in electric shock.



- Do not damage, break, or modify the power cord. Do not place heavy objects on, tug, or unnecessarily bend the power cord.
 - Doing so may result in fire or electric shock.

WARNING



- Remove the power plug itself, not the cord.
 - Tugging the cord may damage it (expose conductors, or cause disconnections, etc.), resulting in fire or electric shock.

•Prohibition of Disassembly or Modification

WARNING



- Do not modify the machine.
→ Doing so may result in fire or electric shock.



- Do not remove the rear lid, cabinet, or covers from the machine.
→ The inside of the machine contains high-voltage parts, which may cause electric shock.



- Use power cord complying with power supply standard in each destination.

•Caution for Location

WARNING



- Do not place the machine in a humid or dusty area.
→ Doing so may result in fire or electric shock.



- Once the machine is in position, secure in place using the casters.
→ If the machine falls over, this could result in personal injury.

CAUTION



- Before moving the machine, remove the power plug from the outlet.
→ If the cord is damaged, this may result in fire or electric shock.



- Do not place the machine in an unstable position, such as on an unsteady support or sloping area.
→ If the machine is dropped or falls over, this could result in personal injury.



- Do not place the machine in a place subject to direct sunlight or heating equipment such as a stove.
→ It may degrade ink quality and affect printing. The machine also may malfunction.
- Avoid placing the machine in a place subject to high or low temperature or high humidity.
→ The paper absorbs moisture and it may cause paper jam or creasing.

This machine is a desktop model. Do not place it on the floor directly.

When using an optional cabinet



- Be sure to lock casters after placing the machine on the STAND.
→ The machine may move or fall over without lock causing personal injury.
- Push the STAND only, not the machine, when you desire to move the machine.
→ Pushing the machine cause it to fall over.

• Locations of Warning Labels

Keep the WARNING labels clean at all times. If labels become damaged or come off, please call our service person.

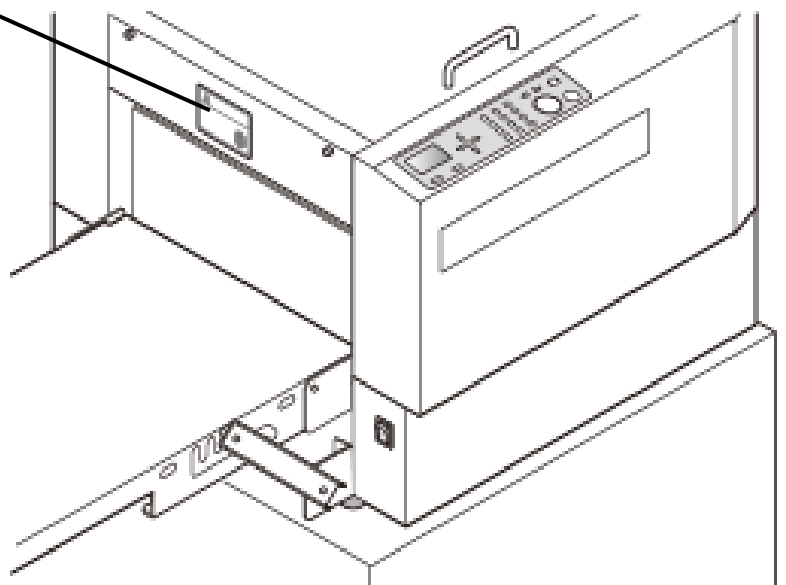
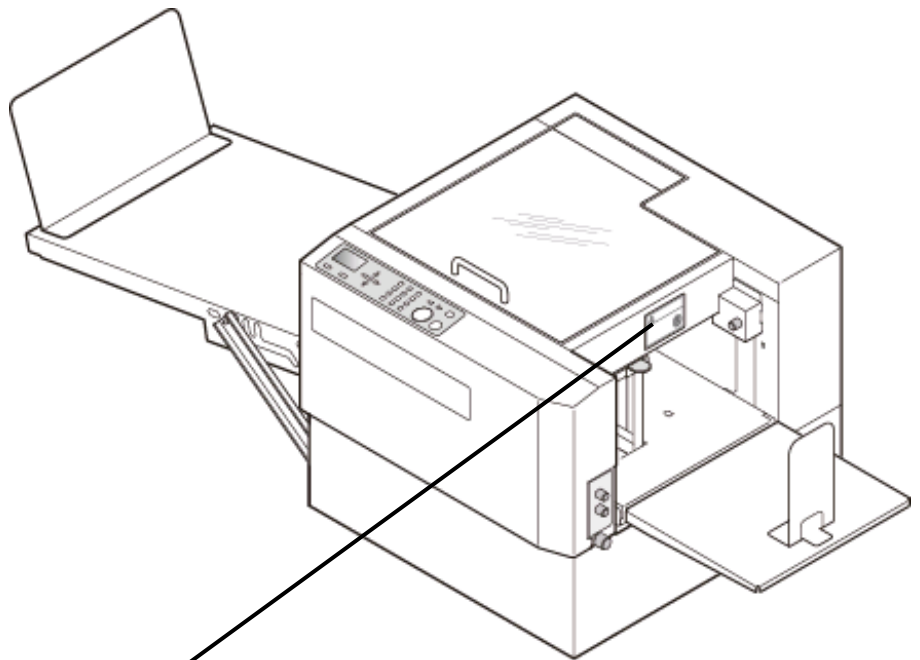

NO.	Part No.	Name	Q'ty
1	M7-T3030	Warning label	2

CONTENTS

	Page
Introduction	1
Notes on Safety	2
Locations of Warning Labels	6

Chapter 1 Before Using This Machine

Part Names and Their Functions	10
●Appearance	10
●Document Ejection Side	11
●Inside	12
●Control Panel	13
●LCD Panel	14
Turning Power ON/OFF	15
●Turning ON the Power	15
●Turning OFF the Power	15
Preparation Before Use	16
●Loading Paper	16
●How to Set the Stacker Tray	17
●Installing the Guide	17

Chapter 2 Programming JOB

Before Programming JOB	19
Programming JOB	19
Setting Functions	20
Entering a New JOB	21
Retrieving a JOB for Processing	24
Setting	26
Adjusting Document Feed	29
Elevator level (Feed Tray)	29
Separator	29
Air Flow	29
Skew	30
Cleaning Feed Rollers	31
Optional Modules	32

Chapter 3 Troubleshooting

Messages	34
When a Paper Jam Has Occurred	37

Chapter 4 Daily Maintenance

Daily Maintenance 39

Chapter 5 Specifications

Specifications 41



Chapter 1 Before Using This Machine



Part Names and Their Functions

●Appearance

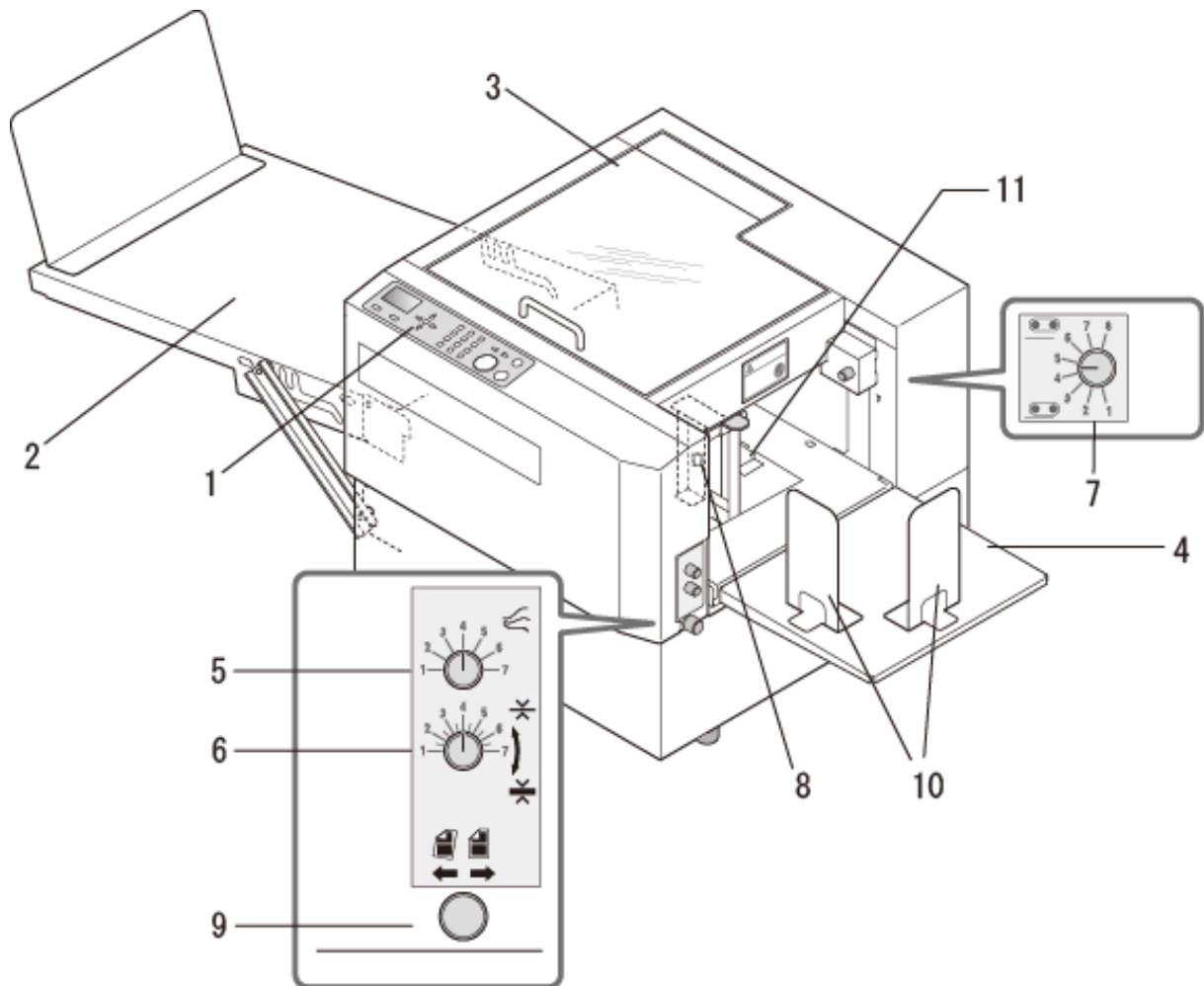

No.	Name	Function
1	Control panel	Displays operations and status.
2	Stacker tray	Receives finished document.
3	Top cover	Open this to remove paper jam from inside of the machine.
4	Feed tray	Original document is placed here.
5	Airflow adjustment knob	Adjusts airflow level.
6	Separator adjustment knob	Adjusts distance between the separator and feed belt.
7	Level adjustment knob	Adjusts the elevator height.
8	Feed tray descend switch	Press to lower the feed tray.
9	Skew adjustment knob	Adjusts the feed angle of document.
10	Side guide	Adjust these according to the paper size.
11	Guide	Installed when the document size is larger than A4.

●Document Ejection Side

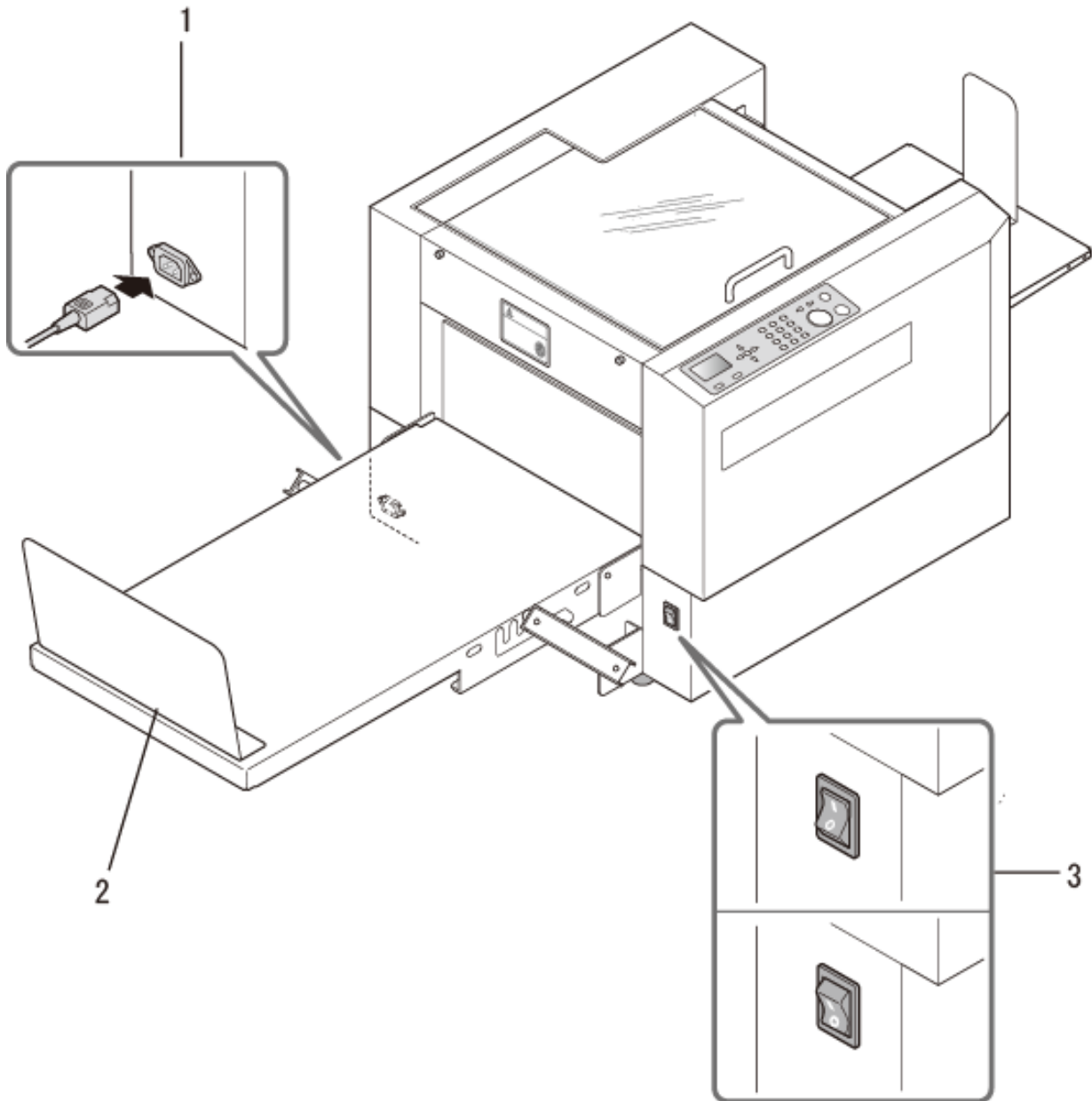

No.	Name	Function
1	AC inlet	Connects the power cord.
2	Back guide	Prevents ejected papers being dropped.
3	Power switch	Press to switch the power on and off.

●Inside

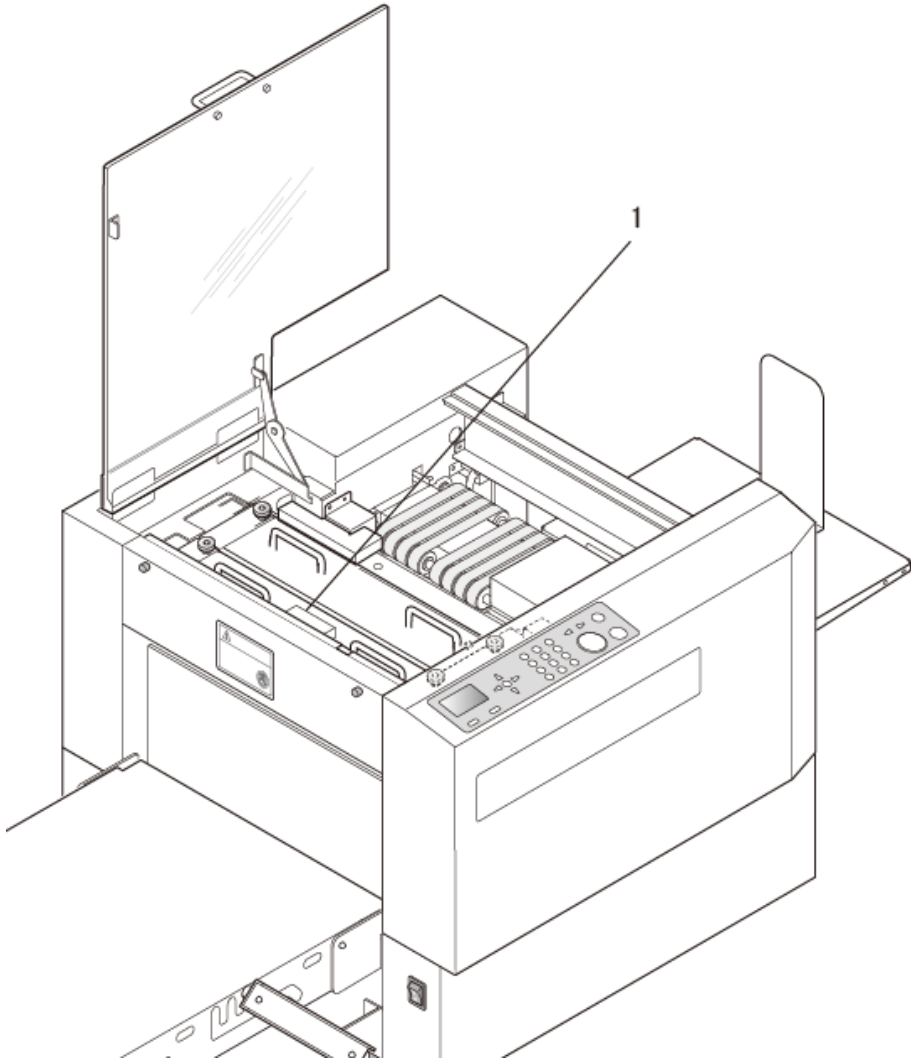

No.	Name	Function
1	Creaser module	Creases parallel in the paper feed direction.

●Control Panel

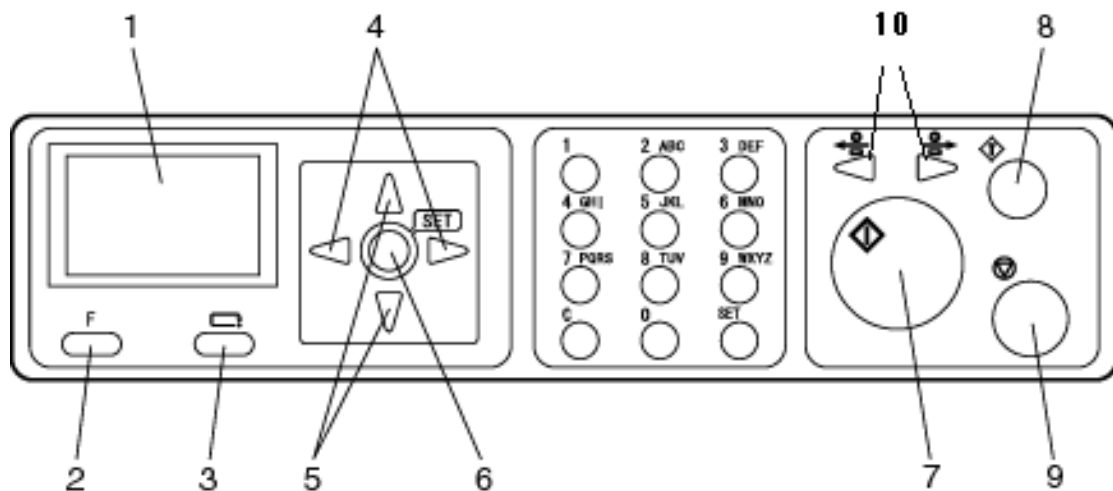

No.	Name	Function
1	LCD panel	Displays the status of the machine. Displays message when an error or paper jam occurs.
2	F key	Switches to function selecting display.
3	↵ RETURN key	Switches the current JOB entering screen to the previous one.
4	Cursor (left/right)	Press to move the cursor to horizontal direction.
5	Cursor (up/down)	Press to move the cursor to vertical direction.
6	SET key	Press to confirm selection / entry.
7	START key	Press to start processing document.
8	TEST key	Press when you want to process one (sheet) document to test the current JOB details.
9	STOP key	Press to stop processing.
10	JOG key	Press to eject the document from the machine when paper jam occurred.

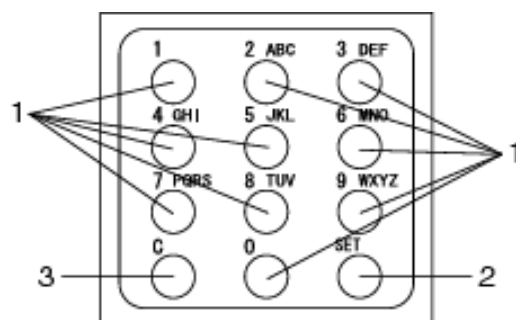

No.	Name	Function
1	Number key	Press to enter JOB / values to process.
2	SET key	Press to fix selection or entry entered by the Number keys.
3	CLEAR key	Press to clear the count.

●LCD Panel

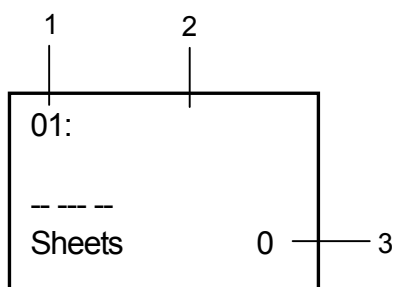

No.	Name	Function
1	JOB No.	Displays JOB No. currently selected.
2	JOB name	Displays JOB name currently selected.
3	Counter	Displays the number of document sheets processed with the JOB currently set.

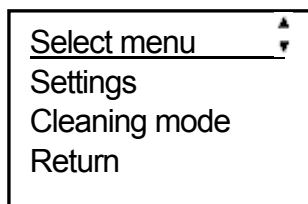
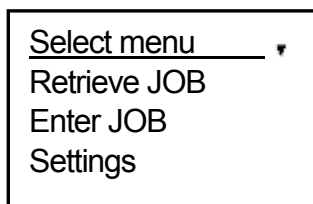

No.	Name	Function
1	Retrieve JOB	Retrieves registered JOB.
2	Enter JOB	Retrieves to enter JOB.
3	Setting	Retrieves to change functions of the machine.
4	Cleaning mode	Retrieves to clean feed belt / feed roller.
5	Return	Returns to stand-by screen.

Turning Power ON/OFF

• Turning ON the Power

1. Connect the 'female plug' of the power cord to the 'inlet'.

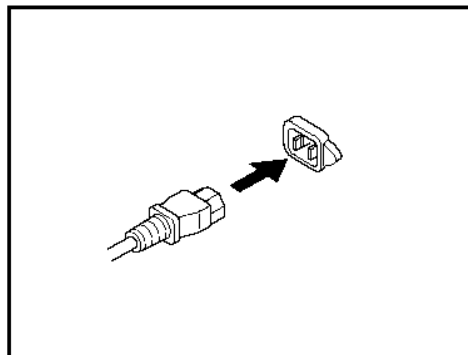

2. Connect the 'male plug' of the power cord to the 'outlet'.

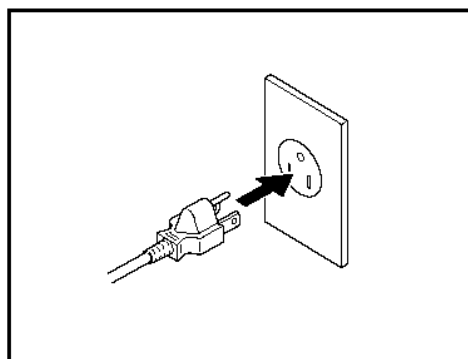

3. Press the 'I' side of the power switch.
Model name of this machine appears on the LCD panel and warming-up stats.

Machine is ready to use when main menu appears on the LCD panel and

Each function of this machine at this time is set to standard mode.

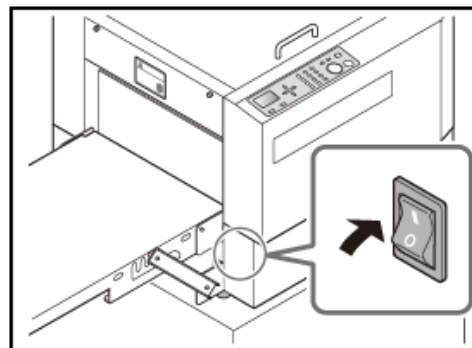

•Turning OFF the Power

1. Press the 'I' side of the power switch.
The power turns off. and display on the LCD panel disappears.

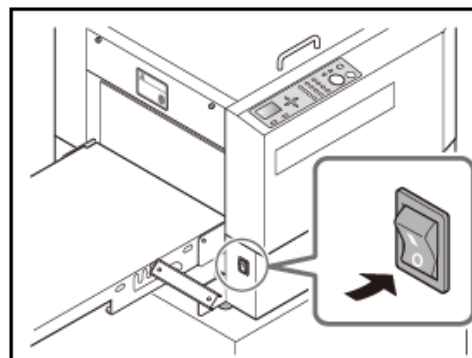

Preparation Before Use

● Loading Paper

1. Fan sheets and align them.
2. Put the sheets on the 'feed tray' and push them to the inside.
3. Adjust the 'side guides' according to the paper size.

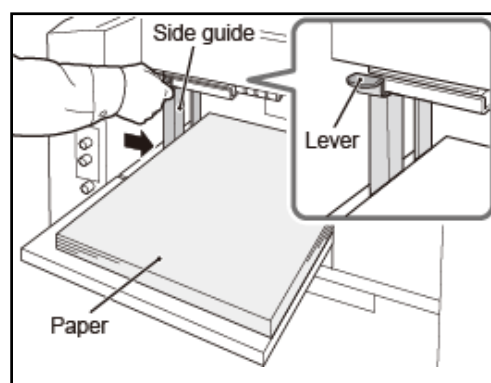
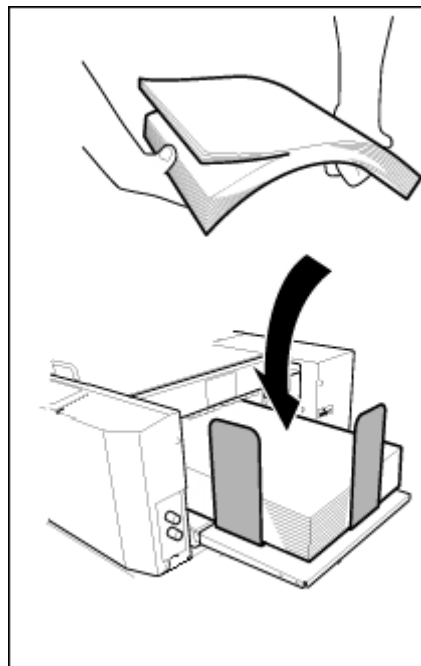

IMPORTANT:
The height of the paper stack should not exceed the 'MAX' level.

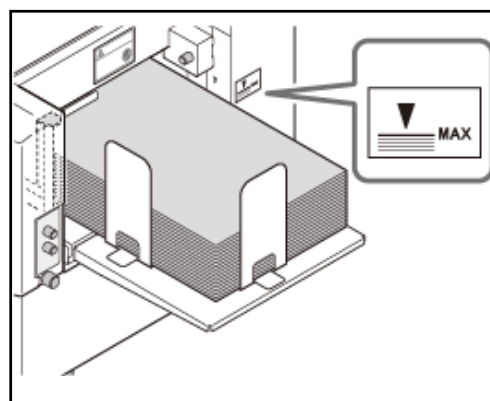

• How to Set the Stacker Tray

1. Open the stacker tray by pressing the stay.
There are 3 setting positions of the stacker tray.

IMPORTANT:

When the finished document size is A3 or longer, or if the finished documents are adhered on the tray due to static electricity, set the stacker tray in the downward position.

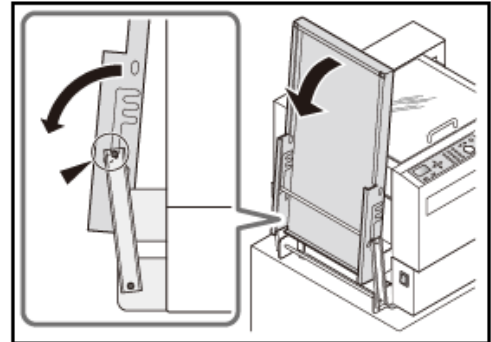
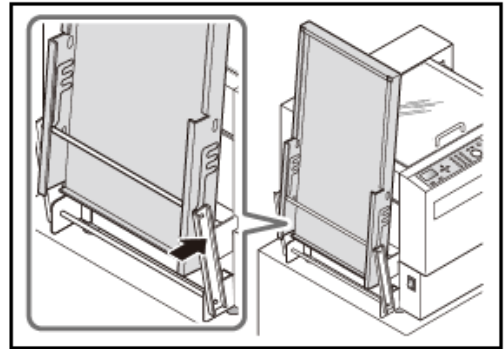

2. Install the back guide.

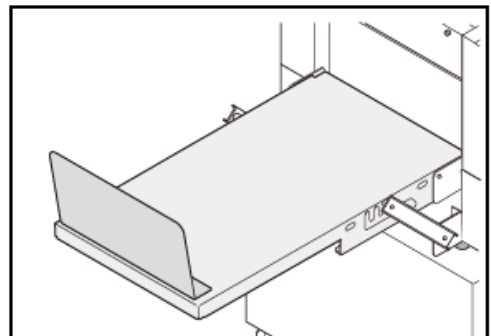

• Installing the Guide

The guide must be installed when the document size is larger than A4.

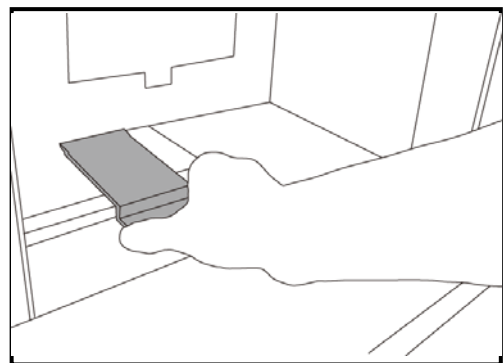

Chapter 2 Programming JOB

Before Programming JOB

The DC-445 can save 30 patterns of JOB. This chapter describes how to program a JOB on the control panel of the DC-445.

Before entering a JOB, accurately measure crease position in mm/inch unit.
Please thoroughly read the description on pages 21 - 23 so that you can create correct JOB.

Programming JOB

The following items should be entered to program a JOB.

JOB number

Select a JOB no. in which the JOB currently being programmed is saved.

JOB name

Put a name to the JOB with Number keys for easy reference.

Paper width

Width of document

Paper length

Length of document

Crease position

Distances between lead edge and each crease position.
The DC-445 can crease up to 15 creases on 1 document.

Air knife (option)

Increases the amount of compressed air to the paper edge when the paper is fed to improve separating performance.

Suction power

Compressed air is blown out to loosen document. This is to prevent double feed.

Crease depth

This sets the depth of the crease when creasing a document. Set to MAX for heavy paper and MIN for light paper.

Speed

This is used to select HIGH/LOW processing speed.

Setting Functions

Various mechanical settings are set when processing takes place.

REFERENCE:

Display for option appears when option is installed on the machine.

Slit / Perf (option)

Sets option (Slit or Perf) to ON or OFF.

Air knife (option)

Refer to the description in the Programming JOB (page 19).

Suction power

Refer to the description in the Programming JOB (page 19).

Crease depth

Refer to the description in the Programming JOB (page 19).

Speed

Refer to the description in the Programming JOB (page 19).

Feeder capacity

The height of the elevator can be adjusted to 3 levels according to user's usage.

Double detection (DOUBLE FEED)

This detects whether the document is double fed.

If double feed is detected, 'Double Feed' appears on the LCD panel.

Select unit

When entering a JOB, unit of dimensions of the printed document you want to cut can be selected in mm or inch.

REFERENCE:

When selecting inch, " is displayed beside the number of the dimensions.

Apply shrinkage

In case printed documents are shrunk by heat generated on digital printer, by entering the original paper size and paper size after shrunk, the DC-445 automatically calculates the shrinkage ratio and adjusts the creasing position accordingly. This function compensates for the shrinkage in the feed direction only.

Adjust all

In case printed document is skewed horizontally, you can correct the skew.

Entering a New JOB

Hints for entering a JOB:

- Pressing the SET key goes on the next step.
- Pressing the ▲ key returns to the previous step.
- Pressing the ▼ key goes on the next step.
- Pressing the ⏻ STOP key while entering JOB ends JOB entering and returns to the main menu.

REFERENCE:

The following setting examples are when all options are installed. Therefore, some displays may be different from the actual one depending on what option is installed.

1. Turn on the power.

2. Make sure that the LCD panel displays stand-by screen.

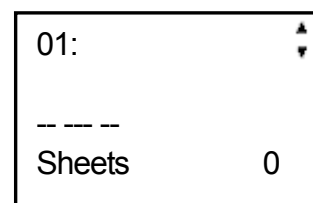

3. Press the F key.

'Select menu' screen appears.

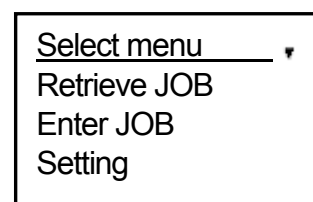

4. Select 'Enter JOB' using the cursor (UP/DOWN) key and press the SET key.

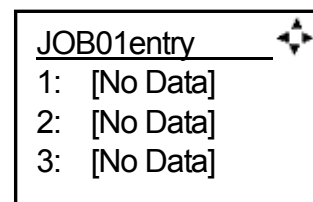

5. Select the JOB no. (01-30) and enter JOB name using the Number keys or cursor (UP/DOWN) key, and then press the SET key.

6. Use the Number key pad to enter the JOB name.

Up to 13 characters can be entered. Refer to the table below for available characters.

Press the SET key when input is completed.

1	1	!	”	\$	%	&	'	()	1
2	A	B	C	a	b	c	2	A		
3	D	E	F	d	e	f	3	D		
4	G	H	I	g	h	i	4	G		
5	J	K	L	j	k	l	5	J		
6	M	N	O	m	n	o	6	M		
7	P	Q	R	S	p	q	r	s	7	P
8	T	U	V	t	u	v	8	T		
9	W	X	Y	Z	w	x	y	z	9	W
0										
C	Clear									
◀	Space, Moves the cursor to the left.									
▶	Space, Moves the cursor to the right.									

Example: DUPLO

1. Press the <3> key and the ► cursor key

JOB01entry 1/24 ▲▼
Enter JOB name
D

2. Press the <8> key 2 times and the ► cursor key.

JOB01entry 1/24 ▲▼
Enter JOB name
DU

3. Press the <7> key and the ► cursor key.

JOB01entry 1/24 ▲▼
Enter JOB name
DUP

4. Press the <5> key 3 times and the ► cursor key.

JOB01entry 1/24 ▲▼
Enter JOB name
DUPL

5. Press the <6> key 3 times and the ► cursor key.

6. Press the SET key

JOB01entry 1/24 ▲▼
Enter JOB name
DUPLO

7. Enter the total width (in mm) of the document using the Number keys.
Press the SET key.

JOB01entry 2/24 ▲▼
Width
210.0mm ⇄ 
(140.0-320.0)

8. Enter the total length (in mm) of the document using the Number keys.
Press the SET key.

JOB01entry 3/24 ▲▼
Length
150.0mm ⇄ 
(150.0-650.0)

9. Enter the distance from the leading edge of the document to the position for the first crease using the Number key.
Press the SET key.

JOB01entry 4/24 ▲▼
Creaser 1
0.0mm ⇄ 
(0.0-150.0)

Hereafter, you can set to Crease 15 similarly.



10. (Only for machine installed with air knife)
 Set Air knife ON or OFF.
 If double feed occurs frequently, set the Air knife ON.
 Press the SET key.

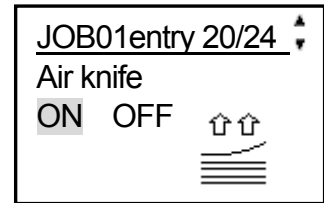

11. Adjust Suction power.
 Select MAX, MID, or MIN.
 Press the SET key.

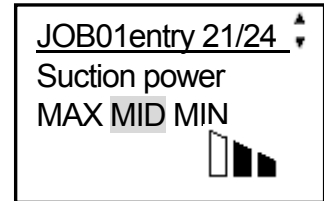

12. Adjust Crease depth.
 Select MAX, MID, or MIN.
 Press the SET key.



13. Select Speed.
 Select FAST or SLOW.

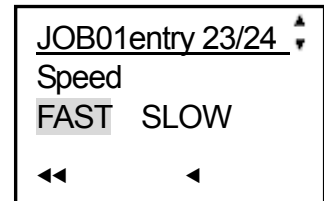

14. Press the SET key to save the settings.
 Press the  STOP key to cancel the settings.

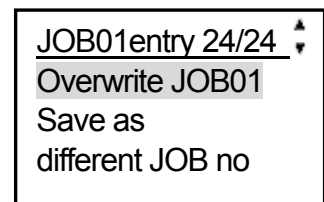

REFERENCE:

The JOB is registered with different JOB no. by selecting “Save as different JOB no”.

Retrieving a JOB for Processing

1. Turn the power ON.
2. Make sure that the LCD panel displays stand-by screen.
3. Press the F key.
'Select menu' screen appears.
4. Select 'Retrieve JOB' using the cursor (UP/DOWN) key and press the SET key.
5. Select 'Retrieve JOB no.' or 'Retrieve JOB log' and press the SET key.

```
Select menu ▾  
Retrieve JOB  
Enter JOB  
Setting
```

'Retrieve JOB no.': JOB no. is displayed in ascending order.
'Retrieve JOB log': JOB no. is displayed in descending order from the last processed JOB.

```
Retrieve JOB  
Retrieve JOB no.  
Retrieve JOB log  
Return
```

REFERENCE:

- Press the cursor key (LEFT/RIGHT) when cursor is under JOB no. to confirm the settings of the JOB no.
(The details of JOB01 is displayed here.)
- JOB no. can be entered also using the Number key after selecting 'Retrieve JOB no.' or 'Retrieve JOB log'.

```
Retrieve JOBXX ✦  
1 : JOB 01  
2 : JOB 02  
3 : [ NO DATA]
```

```
JOB01 property ◀ ▶  
Width XXX.X mm  
Length XXX.X mm
```

6. Prepare sheets according to the retrieved JOB.

IMPORTANT:

Please fan sheets before loading them on the feed tray.

7. Put the sheets on the feed tray.
8. Set the side guides.
9. Set the stacker tray.

REFERENCE:

- When finished document size is A4 (longitudinal) or longer, set the stacker tray in the downward position.
- If finished documents are adhered on the stacker tray due to static electricity, set the stacker tray in the downward position.

10. Install the back guide.

11. Make sure that the LED of the  START key lights up in green.

Press the  START key.

If the LED is red, error may be occurring. Please follow the instructions on the LCD panel.

Setting

REFERENCE:

Contents registered in the “Setting” changes the JOB temporarily.

Please note that changed setting is cleared and does not overwrite the already registered JOB when the power to the machine is turned OFF.

However, the following 2 settings are valid for all JOBS and stored in the machine.

- Setting Select unit mm / inch
- Setting Double detection ON/OFF

1. Turn the power ON.

2. Make sure that the LCD panel displays stand-by screen.

3. Press the F key.

‘Select menu’ screen appears.

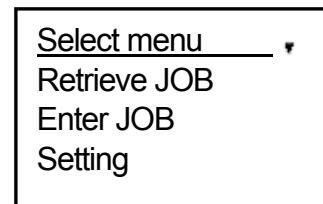

4. Select ‘Setting’ using the cursor (UP/DOWN) key and press the SET key.

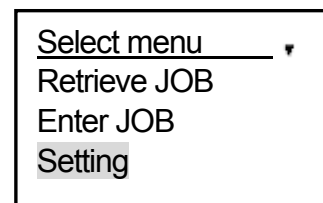

5. Please perform each setting with referring to the right pictures.

5-1. Slit / Perf (option)
Select ON or OFF.

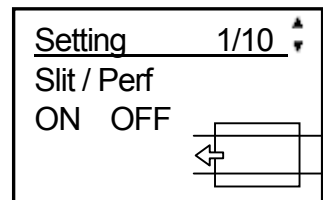

5-2. Air knife (option)
Increases the amount of compressed air to the paper edge when the paper is fed to improve separating performance.
Select ON or OFF.

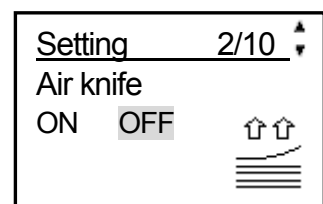

5-3. Suction Power
Compressed air is blown out to loosen document.
This is to prevent double feed.
Select MAX, MID, or MIN.

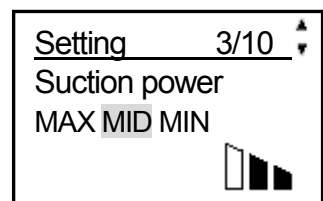

5-4. Crease depth

This sets the depth of the crease when creasing a document.
Set to MAX for heavy paper and MIN for light paper.

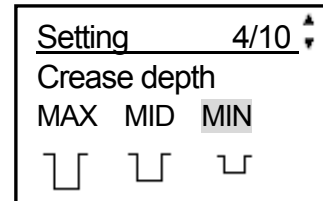

5-5. Speed

This is used to select HIGH/LOW processing speed.

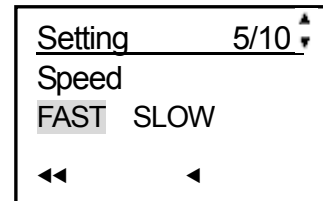

5-6. Feeder capacity

The height of the elevator can be adjusted to 3 levels according to user's usage.

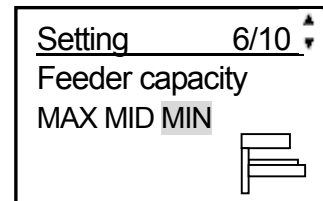

5-7. Double detection (DOUBLE FEED)

This detects whether the document is double fed.
If double feed is detected, 'Double Feed' appears on the LCD panel.

IMPORTANT:

When rough-textured paper is used, double feed may not be detected.

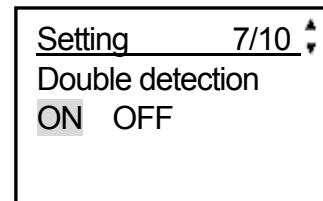

5-8. Select unit

When entering a JOB, unit of dimensions of the printed document you want to cut can be selected in mm or inch.

REFERENCE:

When selecting inch, " is displayed beside the number of the dimensions.

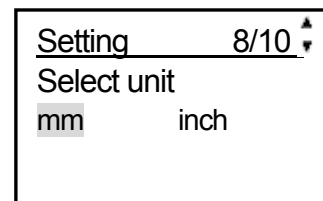

5-9. Apply shrinkage

In case printed documents are shrunk by heat generated on digital printer, by entering the original paper size and paper size after shrunk, the DC-445 automatically calculates the shrinkage ratio and adjusts the creasing position accordingly. This function compensates for the shrinkage in the feed direction only.

REFERENCE:

When Shrinkage is set, rear edge crease position is out of specification.

Set Shrinkage function OFF or change the rear edge crease position.

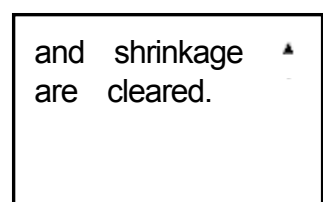
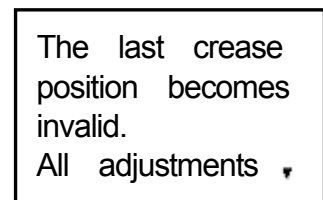
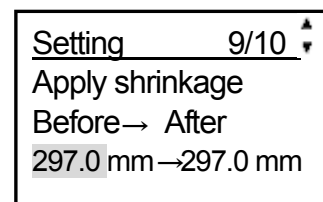

5-10. Adjust all

In case printed document is skewed horizontally, you can correct the skew.

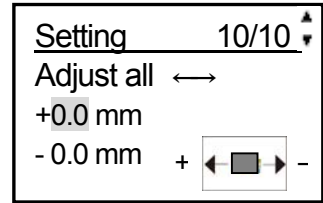

Adjusting Document Feed

Elevator level (Feed tray)

The elevator level should be adjusted in the following cases.

- a. The machine does not feed.
Turn the knob in the counterclockwise direction (to a smaller number).
The level of the elevator is raised.
- b. The machine feeds multiple sheets at once. (double feed)
Turn the knob in the clockwise direction (to a larger number).
The level of the elevator is lowered.

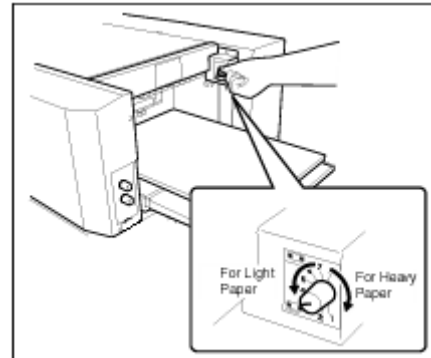

Separator

The height of the separator should be adjusted in the following cases.

- a. The machine does not feed.
Turn the knob in the clockwise direction. (to a larger number)
The position of the separator is lowered.
- b. The machine feeds multiple sheets at once. (double feed)
Turn the knob in the counterclockwise direction (to a smaller number).
The position of the separator is raised.

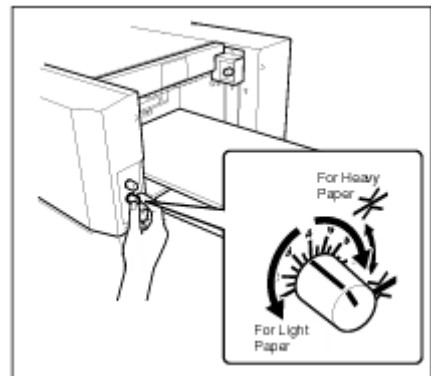

Airflow

The amount of airflow should be adjusted in the following cases.

- a. The machine does not feed.
Turn the knob in the clockwise direction (to a larger number). The amount of airflow is increased.
- b. The machine feeds multiple sheets at once. (double feed)
Turn the knob in the counterclockwise direction (to a smaller number). The amount of airflow is decreased.

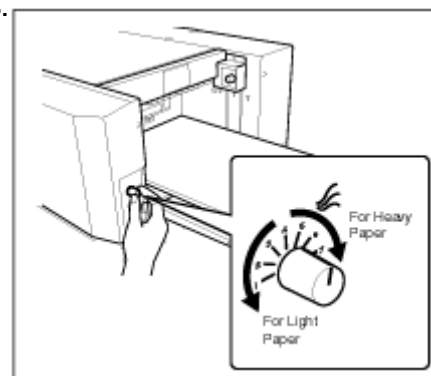

Skew

If finished document is skewed, adjust the skew adjustment knob.

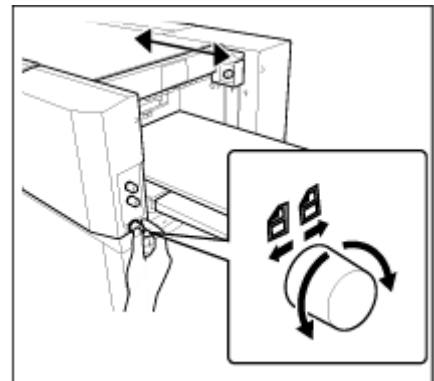

Cleaning Feed Rollers

As the DC-445 processes digital color outputs, toner etc. on the documents may adhere to the surface of the feed rollers of the DC-445. When the accumulation of such toner becomes excessive, it may affect the performance of the DC-445. In this case, clean the rollers in the following procedures.

1. Turn on the machine.
2. Make sure that the LCD panel displays stand-by screen.
3. Press the F key.
'Select menu' screen appears.

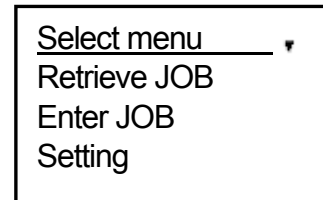

4. Select 'Cleaning mode' using the cursor key (UP/DOWN) key and press the SET key.

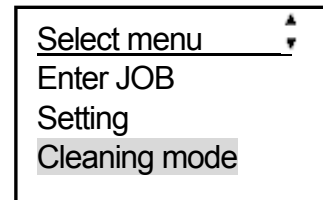

5. Open / Close the top cover.
Every time the top cover is opened/closed, the feed rollers turn 60 degrees. Wipe-off the toner and debris on the rollers using a tightly wrung cloth by opening/closing the top cover.

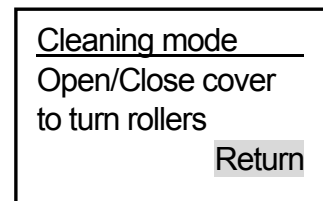

IMPORTANT:

Do not wipe the rollers with anything other than that designated above. Use of anything else may result in mechanical malfunction.

WARNING:

Do not put your hands or fingers in the feeding part when cleaning. Your hands or fingers may be caught and get injured.

6. After cleaning the rollers, press the SET key.
'Select menu' screen appears.

Optional Modules

You can make slits or perforations in the paper by installing the optional modules (slitter module, perforation module).

Chapter 3 Troubleshooting

Messages

When an error occurs, illustration and message about the error are displayed on the LCD panel. In such cases, take measures according to the following instructions.

Message	Status and Countermeasures
<p>No paper Set document on feed tray ⏏ to Clear</p>	<p><u>Status:</u> There is no document on the feed tray. <u>Countermeasure:</u> Load document on the feed tray.</p>
<p>Cover open Close cover</p>	<p><u>Status:</u> Top cover is open. <u>Countermeasure:</u> Close the top cover.</p>
<p>Double feed Remove document in the machine ⏏ to Clear</p>	<p><u>Status:</u> Double Feed <u>Countermeasure:</u> Remove documents in the machine.</p>
<p>J2 Feed tray Feed tray overload ⏏ to Clear</p>	<p><u>Status:</u> Too many documents are loaded on the feed tray. <u>Countermeasure:</u> Set documents so that the height of the document stack should not exceed the 'MAX' level. (There is an indication on the right side of the feed tray.)</p>
<p>J3 Feed error Remove document from feed area ⏏ to Clear</p>	<p><u>Status:</u> Paper jam in the paper feeding area or processing area. <u>Countermeasure:</u> Remove the jammed documents from the paper feeding area or processing area, and press the ⏏ STOP key.</p>
<p>J4 Option area Remove document from option area ⏏ to Clear</p>	<p><u>Status:</u> Paper jam in the option area. <u>Countermeasure:</u> Remove the jammed documents from the option area and press the ⏏ STOP key.</p>



Message	Status and Countermeasures
<div style="border: 1px solid black; padding: 5px;"> <p>J5 Crease Remove document from crease area ⏏ to clear</p> </div>	<p><u>Status:</u> Paper jam in the crease area. <u>Countermeasure:</u> Remove the jammed documents from the crease area and press the ⏏ STOP key.</p>
<div style="border: 1px solid black; padding: 5px;"> <p>J6 Exit tray Remove documents from exit tray ⏏ to Clear</p> </div>	<p><u>Status:</u> Paper jam in the paper exit area. <u>Countermeasure:</u> Remove the jammed documents from the stacker tray and press the ⏏ STOP key.</p>
<div style="border: 1px solid black; padding: 5px;"> <p>Crease lock Check document in crease area ⏏ to Clear</p> </div>	<p><u>Status:</u> Check paper jam in the crease area. <u>Countermeasure:</u> Remove the jammed documents from the crease area and press the ⏏ STOP key.</p> <p>Turn off the power and then turn on the power again after a few seconds. Contact service person if the error remains.</p>
<div style="border: 1px solid black; padding: 5px;"> <p>Paper in machine Remove document from option area</p> </div>	<p><u>Status:</u> Check paper jam in the option area when the power is turned on. <u>Countermeasure:</u> Remove the jammed documents from the option area, and press the ⏏ STOP key.</p>
<div style="border: 1px solid black; padding: 5px;"> <p>Paper in machine Remove document from crease area</p> </div>	<p><u>Status:</u> Check paper jam in the crease area when the power is turned on. <u>Countermeasure:</u> Remove the jammed documents from the crease area, and press the ⏏ STOP key.</p>
<div style="border: 1px solid black; padding: 5px;"> <p>Paper in machine Remove document from exit tray</p> </div>	<p><u>Status:</u> Check paper jam in the paper exit area when the power is turned on. <u>Countermeasure:</u> Remove the jammed documents from the stacker tray and press the ⏏ STOP key.</p>

Message	Status and Countermeasures
	<p><u>Status:</u> Error in DC-445</p> <p><u>Countermeasure:</u> Turn off the power and turn on again after a few seconds. If the same message appears, contact our service person.</p>
<div data-bbox="197 510 507 689" style="border: 1px solid black; padding: 5px;"> <p>The last crease position becomes invalid. All adjustments ▾</p> </div> <div data-bbox="197 728 507 907" style="border: 1px solid black; padding: 5px; margin-top: 10px;"> <p>and shrinkage ▲ are cleared.</p> <p>All adjustments</p> </div>	<p><u>Status:</u> When Shrinkage is set, rear edge crease position is out of specification.</p> <p><u>Countermeasure:</u> Set Shrinkage function OFF or change the rear edge crease position.</p>

When a Paper Jam Has Occurred

When a paper jam has occurred, the lamp blinks on the LCD panel and a message is displayed on the LCD panel. Remove the jam according to the following procedures.

WARNING

- Do not touch the blade. Doing so may cause injury.
- Before removing paper, make sure the machine is fully stopped. Use the pliers that come with the machine to prevent your hands or fingers from being caught or pinched.

J3 Feed error

A document remains in the feed tray or document feed area.

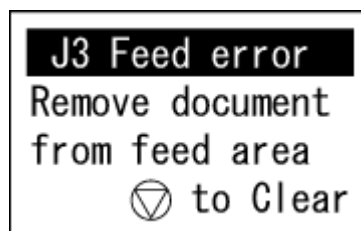

1. Press the  JOG keys to eject the document.

IMPORTANT:

Be sure to close the top cover when you operate the machine.
The machine does not work if the top cover is open.

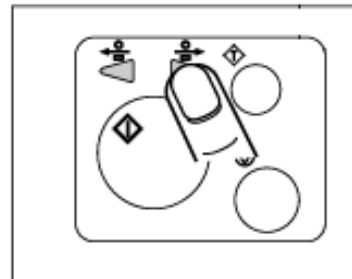

2. Press the  STOP key to clear the error.

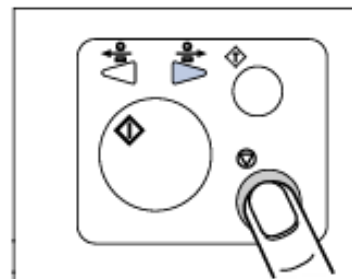

Chapter 4 Daily Maintenance

Daily Maintenance

• How to maintain the machine

Check the machine periodically to maintain its performance.



WARNING

- Before cleaning, be sure to turn the power off, wait until the machine cools off and unplug the power cord. Otherwise, fire or electric shock may occur.
- Never remove covers on the machine or modify them.
- Do not spill water or any liquid inside of the machine. It may cause fire or electric shock. If it happens, contact our service person.

Clean the exterior in the following procedures.

1. Use soft cloth with water or mild detergent.
2. Wipe the exterior.
3. Wipe off the liquid with dry soft cloth.



WARNING

- Never use alcohol or solvent cleaner. It may tarnish or damage the exterior finish.
- Do not put diluted petroleum or insecticide. It may cause fire.

Dust accumulation may cause the machine to malfunction. Clean it once a week. Contact our dealer as for cleaning of inside of the machine.

Chapter 5 Specifications

1	Model name	DuCreaser DC-445	
2	Product name	Table top creaser	
3	Feed	Belt suction	
4	Feed tray capacity	100mm	
5	Infeed Paper size	Width: 140mm – 320mm Length : 150mm- 650mm Standard feed tray supports up to 460mm length of documents For longer documents, optional long paper tray is available.	
6	Minimum finishing size when using optional slitter unit	Width 48.0mm	
7	Paper type	Uncoated paper, coated paper, laminated paper	
8	Paper weight	110gsm- 350gsm	Paper curl within +/-3mm
9	Speed	50ppm (A4 SEF 1 crease)	
10	Crease	Max 15 creases per document	
11	Crease accuracy	+/-0.3mm	
12	Crease depth adjustment	3 steps (from control panel)	
13	Exit tray	110mm	
14	Control panel	64dot x128dot LCD	
15	LCD languages	Japanese English German French Italian Spanish Polish Russian	
16	Standard feature	Max 30 Job memory Test feed Skew adjustment	

17	Optional features	Air Knife (compressor for additional paper separation when feeding) Double Feed Detection Long Paper Tray (holds up to 650mm) Stand Slitter unit (Option module is required) Perforation unit (Option module is required.)	
18	Power supply 115VAC model	115VAC、 50/60Hz	
	230VAC model	230VAC、 50Hz	
19	Power consumption	100V : current consumption 2.1A, power consumption 180W 115V : current consumption 1.7A, power consumption 160W 230V : current consumption 0.8A, power consumption 160W	
20	Machine dimension	In use : 1262mm(W) x 618.2 mm(D) x 573.3 mm(H)	
21	Machine weight	79 kg	
22	Operating temperature	10-30 degree (Celsius)	
23	Operating humidity	40% - 70%	

* Specifications are subject to change without prior notice.



Reproduction prohibited

1st printing : 2007

Issued by : **DUPLO CORPORATION**

PRINTED IN JAPAN



MyBinding.com
When Image Matters.

DUPLO CORPORATION

Duplo building, 1-6, Oyama 4 chome, Sagamihara, Kanagawa 229-1180, Japan

PHONE: +81-42-775-3602

FAX: +81-42-775-3606

E-mail: info@duplo.com

S7-Y1041 2007.12

ivy *When Image Matters.* **.co**