

Fujipla Almeister ALM3220 Laminator

Parts List



Provided By

MyBinding.com
When Image Matters.

Fig.1

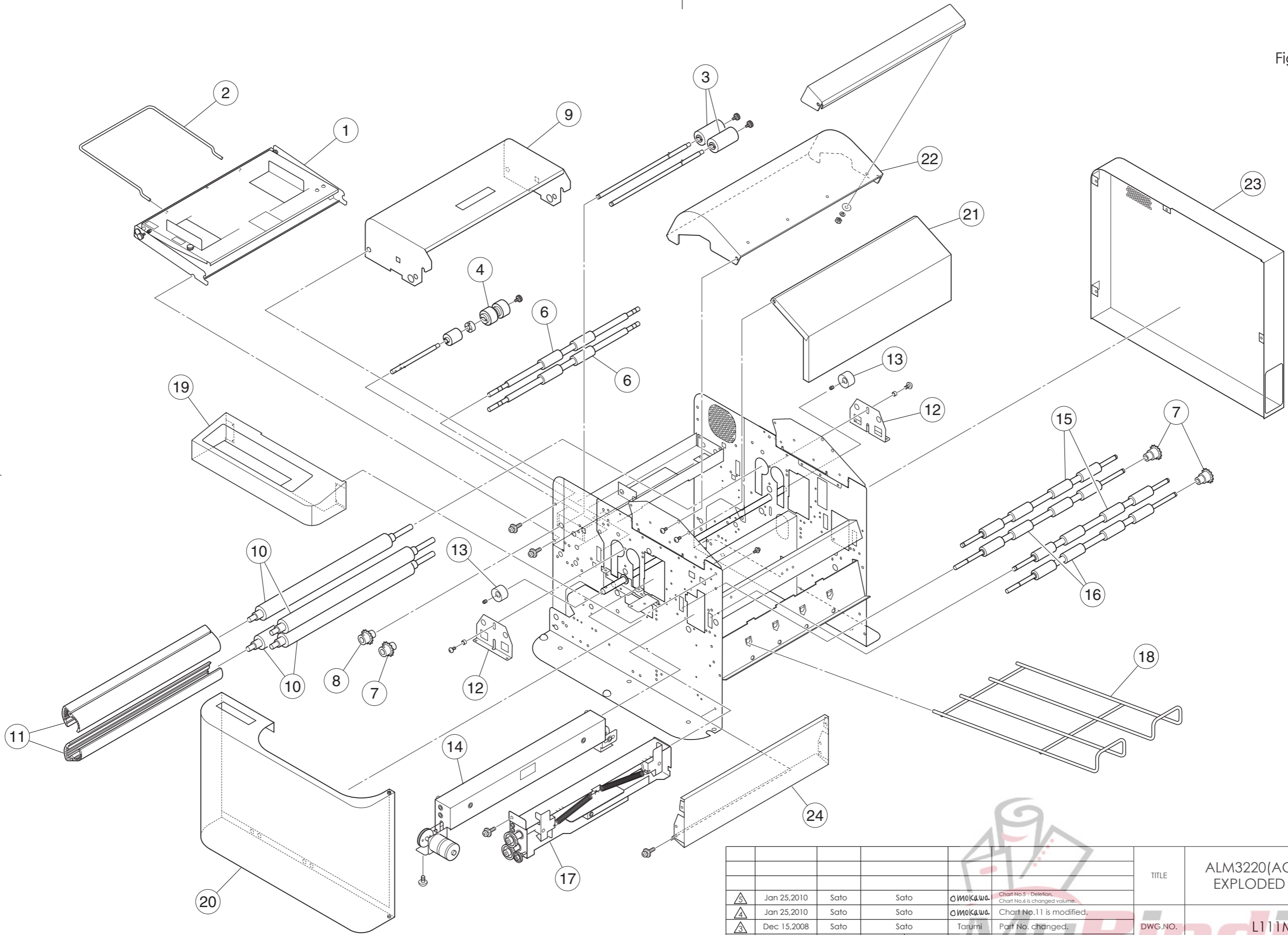

REV	DATE	DRAWN	CHECKED	ENG APPR.	COMMENTS	
△	Jan 25,2010	Sato	Sato	OMOKAWA	Chart No.5 - Deletion. Chart No.6 is changed volume.	
△	Jan 25,2010	Sato	Sato	OMOKAWA	Chart No.11 is modified.	
△	Dec 15,2008	Sato	Sato	Tarumi	Part No. changed.	
△	Sep 7,2007	Yamamoto	Kiyono	Tarumi	Yamazaki	Redrawn at exploded view.
△	Nov 9,2006	Sato	Kiyono	Tarumi	Yamazaki	New Drawing.

TITLE	ALM3220(AC120V) EXPLODED VIEW	SCALE
DWG.NO.	L111M-U101	
		SHEET 1/10

ALM3220(AC120V) Fig.1			
No.	Part No.	Part Name	Q't
△3	1	967063 Feeder Tray Assy(US)	1
	2	967022 Extension Tray	1
	3	967005 Feeding Roller E	2
	4	967006 Feeding Roller	1
△5	6	967008 Upper Feeding (Transport) Roller	1
	7	967023 Sprocket 12T-12	3
	8	967024 Sprocket 13T-12	1
	9	967009 Feeder Cover	1
△4	10	967010 Heating Roller(Pull Roller)	4
	11	967011 Chamber	2
	11	967095 Chamber(Silver)	2
	12	967012 Press Plate	2
	13	967013 Cam	2
	14	967014 Cutter Unit	1
	14	967015 Cutter Unit Component Exchange(Rotary Blade)	1
	14	967044 Cutter Unit Component Exchange(Rotary Blade & Related Parts)	1
	15	967016 Upper Transport Roller	2
	16	967017 Lower Transport Roller	2
	17	967065 Trimmer Unit(US)	1
	17	967019 Trimmer Unit Component Exchange(Rotary Blade)	1
	18	967067 Rear Tray(US)	1
	19	967029 Operation Panel Cover	1
20	967030 Front Door	1	
21	967031 Exit Cover	1	
	22	967032 Upper Film Roll Cover	1
	23	967033 Rear Side Cover	1
	24	967034 Right Side Cover	1

△4 : applied to M/C No.0000649 and above, also applicable to below this M/C No.0000649.
 △5 : applied to M/C No.0000007 and above, also applicable to below this M/C No.0000007.



REV	DATE	DRAWN	CHECKED	ENG APPR.	COMMENTS	TITLE	SCALE
						ALM3220(AC120V) EXPLODED VIEW	
△5	Jan 25,2010	Sato	Sato	OMOKAWA	Chart No.5 : Deletion. Chart No.6 is changed volume.	DWG.NO. L111M-U101	
△4	Jan 25,2010	Sato	Sato	OMOKAWA	Chart No.11 is modified.		
△3	Dec 15,2008	Sato	Sato	Tarumi	Part No. changed.		
△2	Sep 7,2007	Yamamoto	Kiyono	Tarumi	Yamazaki		Redrawn at exploded view.
	Nov 9,2006	Sato	Kiyono	Tarumi	Yamazaki		New Drawing.
						 FUJIPA Inc.	SHEET 2/10

Fig.2

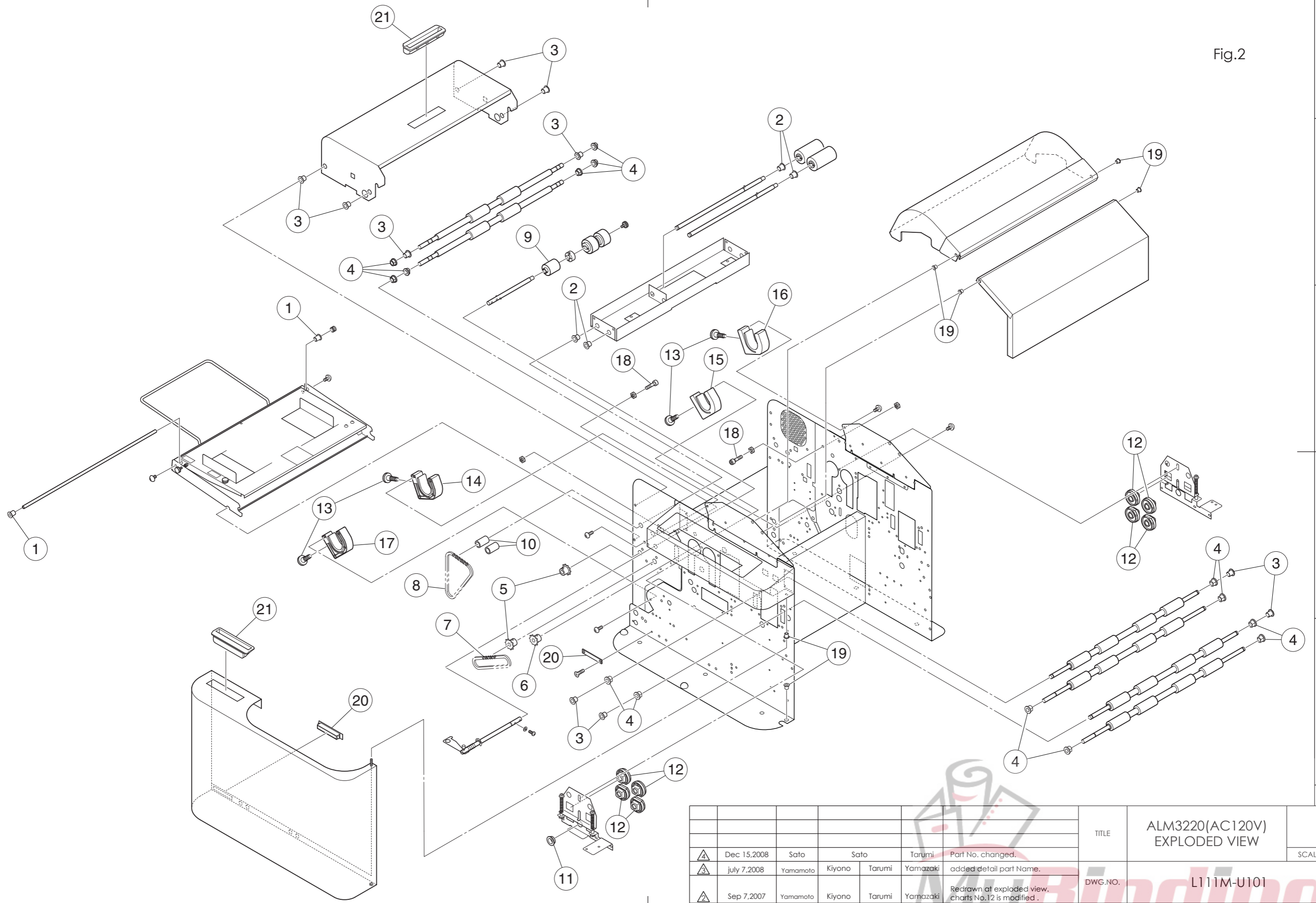

REV	DATE	DRAWN	CHECKED	ENG APPR.	COMMENTS	TITLE	DWG.NO.	SCALE
						ALM3220(AC120V) EXPLODED VIEW	L111M-U101	
▲	Dec 15,2008	Sato	Sato	Tarumi	Part No. changed.			
▲	July 7,2008	Yamamoto	Kiyono	Tarumi	Yamazaki	added detail part Name.		
▲	Sep 7,2007	Yamamoto	Kiyono	Tarumi	Yamazaki	Redrawn at exploded view, charts No.12 is modified .		
	Nov 9,2006	Sato	Kiyono	Tarumi	Yamazaki	New Drawing.		

	1		2		3		4
A							
B	ALM3220(AC120V) Fig.2						
	No.	Part No.	Part Name			Qt'	
	1	967035	Oiless Bearing			2	
	2	967036	Oiless Bearing			4	
	3	967037	Oiless Bearing			10	
	△ ₃	4	967038	Oiless Bearing(LED-0807)			14
	5	967025	Sprocket			2	
	6	967026	Sprocket			1	
	7	967041	Chain			1	
	8	967042	Chain			1	
	9	967045	Torque Limitter			1	
	10	967046	One-way Clutch Bearing			2	
	11	967039	Oiless Bearing			1	
	12	967047	Chamber Cap			8	
	△ ₂	12	967061	Chamber Cap			8
	13	963001	Tension Knob			4	
	14	967001	Upper Mandrel Holder①			1	
	15	967002	Lower Mandrel Holder①			1	
	16	967003	Upper Mandrel Holder②			1	
	17	967004	Lower Mandrel Holder②			1	
	18	967048	Stripper Bolt			2	
19	967040	Oiless Bearing			6		
△ ₄	20	967049	Magnet Catch			1	
21	967054	Handle			2		
C							
D							
E							
F						TITLE	ALM3220(AC120V) EXPLODED VIEW
						DWG.NO.	L111M-U101
	△ ₄	Dec 15,2008	Sato	Sato	Tarumi	Part No. changed.	SCALE
	△ ₃	july 7,2008	Yamamoto	Kiyono	Tarumi	Yamazaki	added detail part Name.
	△ ₂	Sep 7,2007	Yamamoto	Kiyono	Tarumi	Yamazaki	Redrawn at exploded view. Chart No. 12 is modified.
		Nov 9,2006	Sato	Kiyono	Tarumi	Yamazaki	New Drawing.
REV	DATE	DRAWN	CHECKED	ENG APPR.	COMMENTS	 SHEET 4/10 <i>When Image Matters.</i>	

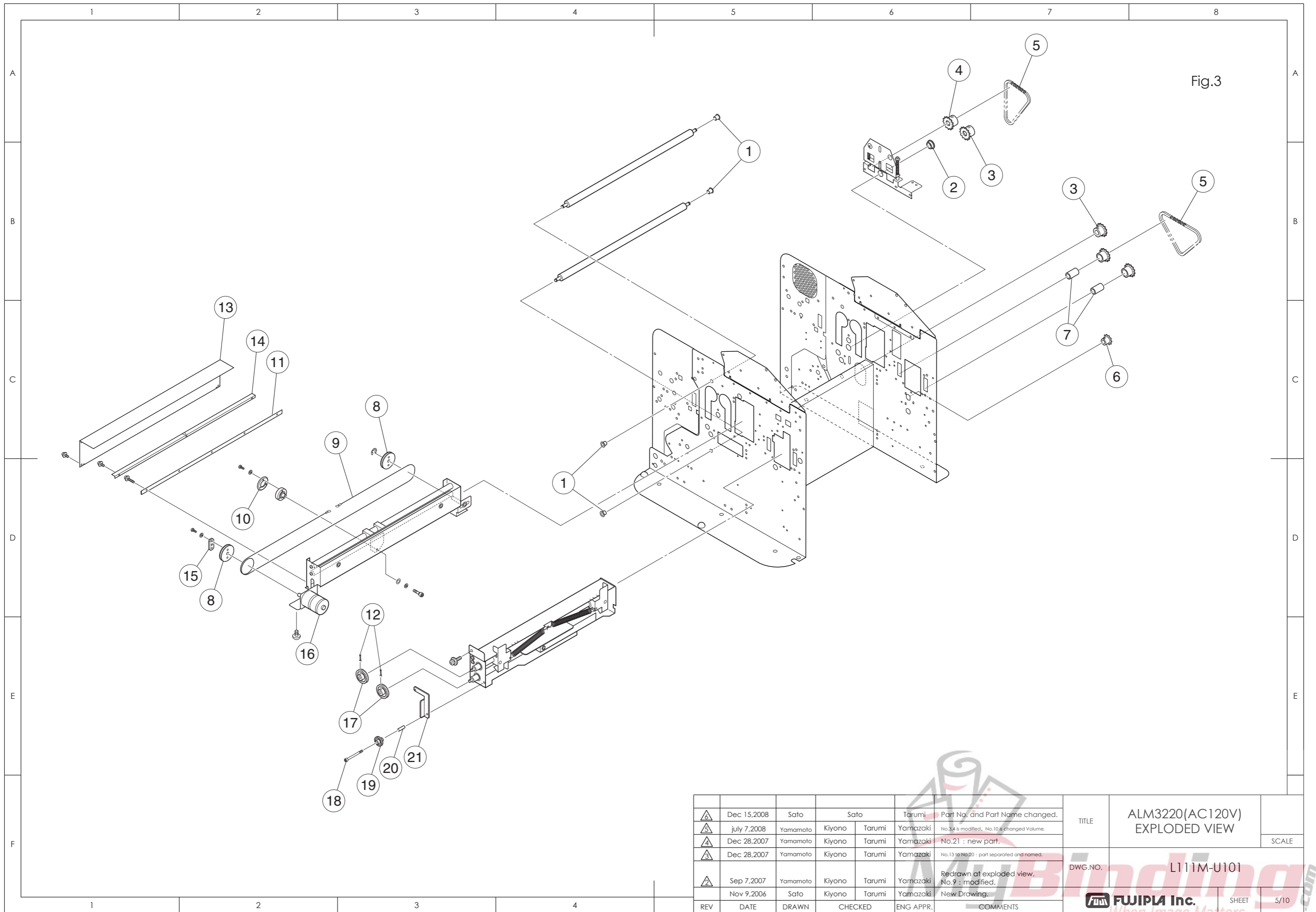



Fig.3

REV	DATE	DRAWN	CHECKED	ENG APPR.	COMMENTS	TITLE	SCALE
	Dec 15,2008	Sato	Sato	Tarumi	Part No. and Part Name changed.	ALM3220(AC120V) EXPLODED VIEW	
	july 7,2008	Yamamoto	Kiyono	Tarumi	Yamazaki		
	Dec 28,2007	Yamamoto	Kiyono	Tarumi	Yamazaki	No.21 : new part.	
	Dec 28,2007	Yamamoto	Kiyono	Tarumi	Yamazaki	No.13 to No.20 : part separated and named.	
	Sep 7,2007	Yamamoto	Kiyono	Tarumi	Yamazaki	Redrawn at exploded view. No.9 : modified.	
	Nov 9,2006	Sato	Kiyono	Tarumi	Yamazaki	New Drawing.	
						DWG.NO. L111M-U101	
						FUJIPA Inc. When Image Matters.	SHEET 5/10

1	2		3		4	
A						
B						
C						
D						
E						
F						

ALM3220(AC120V) Fig.3				
No.	Part No.	Part Name	Qt'	
1	967035	Oiless Bearing	4	
2	967039	Oiless Bearing	1	
3	967027	Sprocket	2	
△5 △6	3	967085	Sprocket(13T)	2
△5 △6	4	967028	Sprocket	1
4	967086	Sprocket(14T)	1	
5	967043	Chain	2	
6	967025	Sprocket	1	
7	967046	One-way Clutch Bearing	2	
8	967060	Pulley	2	
9	967055	Wire	1	
△9	9	967066	Wire Set(φ 1.1mm)	1
△10	10	967058	Rotary Blade	1
11	967059	Counter Blade	1	
12	967057	Split Pin	2	
△13	13	967068	Cutter Cover	1
△14	14	967069	Film Guide	1
△15	15	967073	Pulley Fitting	1
△16	16	998992	Cutter Motor	1
△17	17	967076	Gear 30T	2
△18	18	967077	Stripper Bolt M4	1
△19	19	967078	Gear 20T	1
△20	20	967079	Spacer	1
△21	21	967080	Side Plate	1

△9 : applied to M/C No.0000171 and above, also applicable to below this M/C No.0000171.
△10 : applied to M/C No.0000181 and above, also applicable to below this M/C No.0000181.
△13 △14 : applied to M/C No.0000274 and above, also applicable to below this M/C No.0000274.

△6	Dec 15,2008	Sato	Sato	Tarumi	Part No. and Part Name changed.	TITLE	ALM3220(AC120V) EXPLODED VIEW	SCALE
△5	july 7,2008	Yamamoto	Kiyono	Tarumi	Yamazaki			
△4	Dec 28,2007	Yamamoto	Kiyono	Tarumi	Yamazaki	No.21 : new part.	DWG.NO.	L111M-U101
△3	Dec 28,2007	Yamamoto	Kiyono	Tarumi	Yamazaki	No.13 to No.20 : part separated and named.		
△2	Sep 7,2007	Yamamoto	Kiyono	Tarumi	Yamazaki	Redrawn at exploded view. Chart No. 9 is modified.		
	Nov 9,2006	Sato	Kiyono	Tarumi	Yamazaki	New Drawing.		
REV	DATE	DRAWN	CHECKED	ENG APPR.	COMMENTS	SHEET		

When Image Matters.

Fig.4

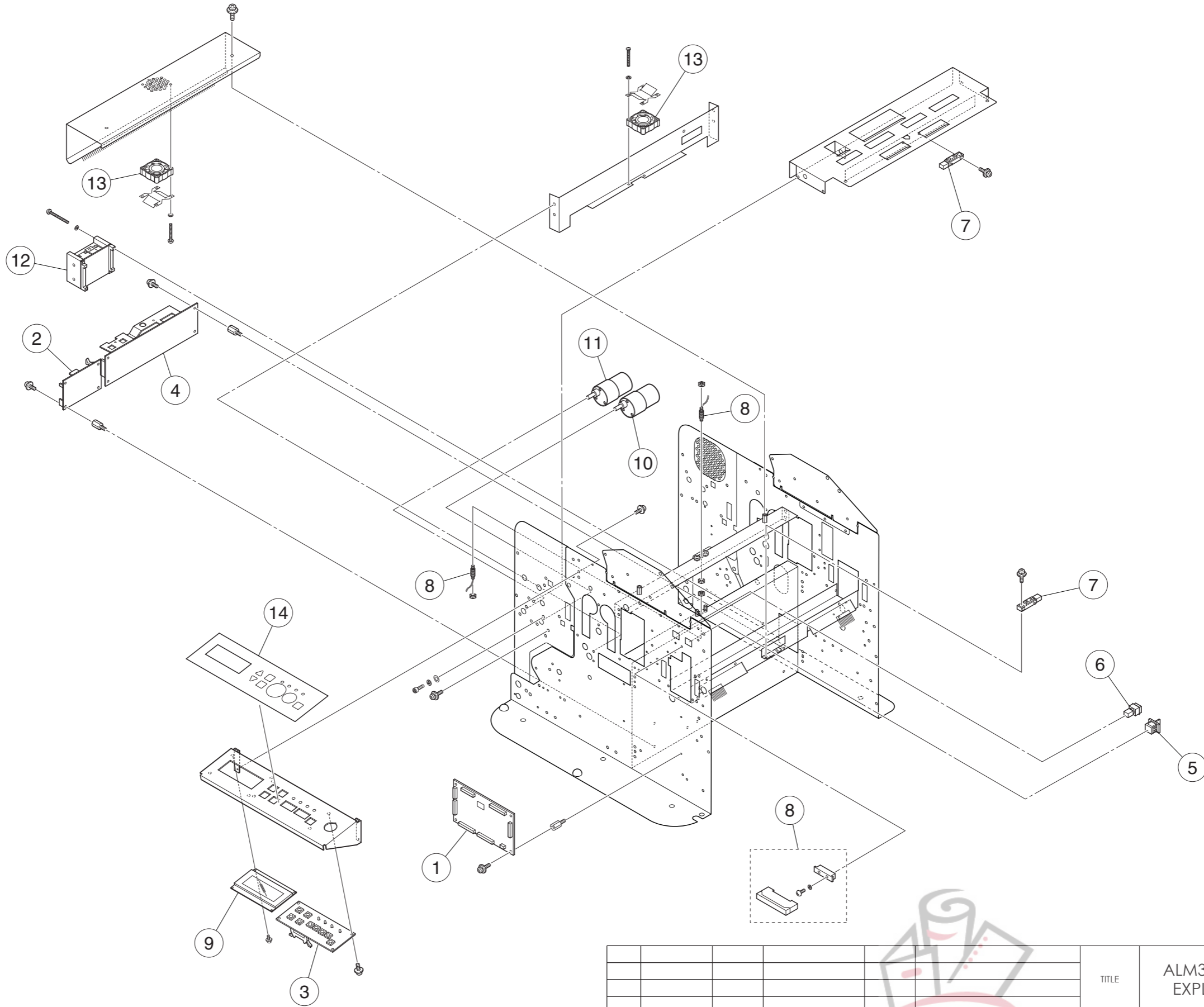

						TITLE	ALM3220(AC120V) EXPLODED VIEW	SCALE	
▲	Jan 28,2009	Sato	Sato	Tarumi	Part No. changed.	DWG.NO.	L111M-U101	SHEET	7/10
▲	Sep 7,2007	Yamamoto	Kiyono	Tarumi Yamazaki	Redrawn at exploded view. Chart No. 9 is modified.				
▲	Nov 9,2006	Sato	Kiyono	Tarumi Yamazaki	charts No.8 is modified.				
▲	Nov 9,2006	Sato	Kiyono	Tarumi Yamazaki	New Drawing.				
REV	DATE	DRAWN	CHECKED	ENG APPR.	COMMENTS				

1

2

3

4

A

B

C

D

E

F

ALM3220(AC120V) Fig.4				
No.	Part No.	Part Name	Qt'	
1	998917	PCB (CPU)	1	
2	998918	PCB (DRIV)	1	
3	998919	PCB (PANEL)	1	
4	998922	24V Regulator	1	
5	998926	Manual Switch for Lamination	1	
6	998927	Manual Switch for cutting	1	
7	998928	Feeder Sensor, Discharge Sensor	2	
8	998929	Cutting Position Sensor	1	
△2	8	998985	Cutting Position Sensor	1
9	998933	LCD(US)	1	
△3	9	998934	LCD(PC2004ARS-AWA-A)	1
10	998936	Stopper Motor, Trimmer Motor	1	
11	998948	Feeder Motor	1	
△4	12	998937	Lamination Motor Driver	1
13	998941	FAN(Heater)	2	
14	998945	Operation Panel	1	

△2 : applied to M/C No.0000031 and above only.

△3 : applied to M/C No.0000360 also applicable to below this M/C No.0000360

REV	DATE	DRAWN	CHECKED	ENG APPR.	COMMENTS	TITLE	SCALE
						ALM3220(AC120V) EXPLODED VIEW	
						DWG.NO. L111M-U101	
△4	Jan 28,2009	Sato	Sato	Tarumi	Part No. changed.		
△3	Sep 7,2007	Yamamoto	Kiyono	Tarumi	Yamazaki	Redrawn at exploded view. Chart No. 9 is modified.	
△2	Nov 9,2006	Sato	Kiyono	Tarumi	Yamazaki	Chart No. 8 is modified.	
	Nov 9,2006	Sato	Kiyono	Tarumi	Yamazaki	New Drawing.	
						 FUJIPA Inc.	SHEET 8/10

Fig.5



REV	DATE	DRAWN	CHECKED	ENG APPR.	COMMENTS	TITLE	DWG.NO.	SCALE
						ALM3220(AC120V) EXPLODED VIEW	L111M-U101	
▲	Jan 28, 2009	Sato	Sato	Tarumi	Part No. changed.			
▲	Sep 7, 2007	Yamamoto	Kiyono	Tarumi	Yamazaki	Redrawn at exploded view.		
	Nov 9, 2006	Sato	Kiyono	Tarumi	Yamazaki	New Drawing.		

1

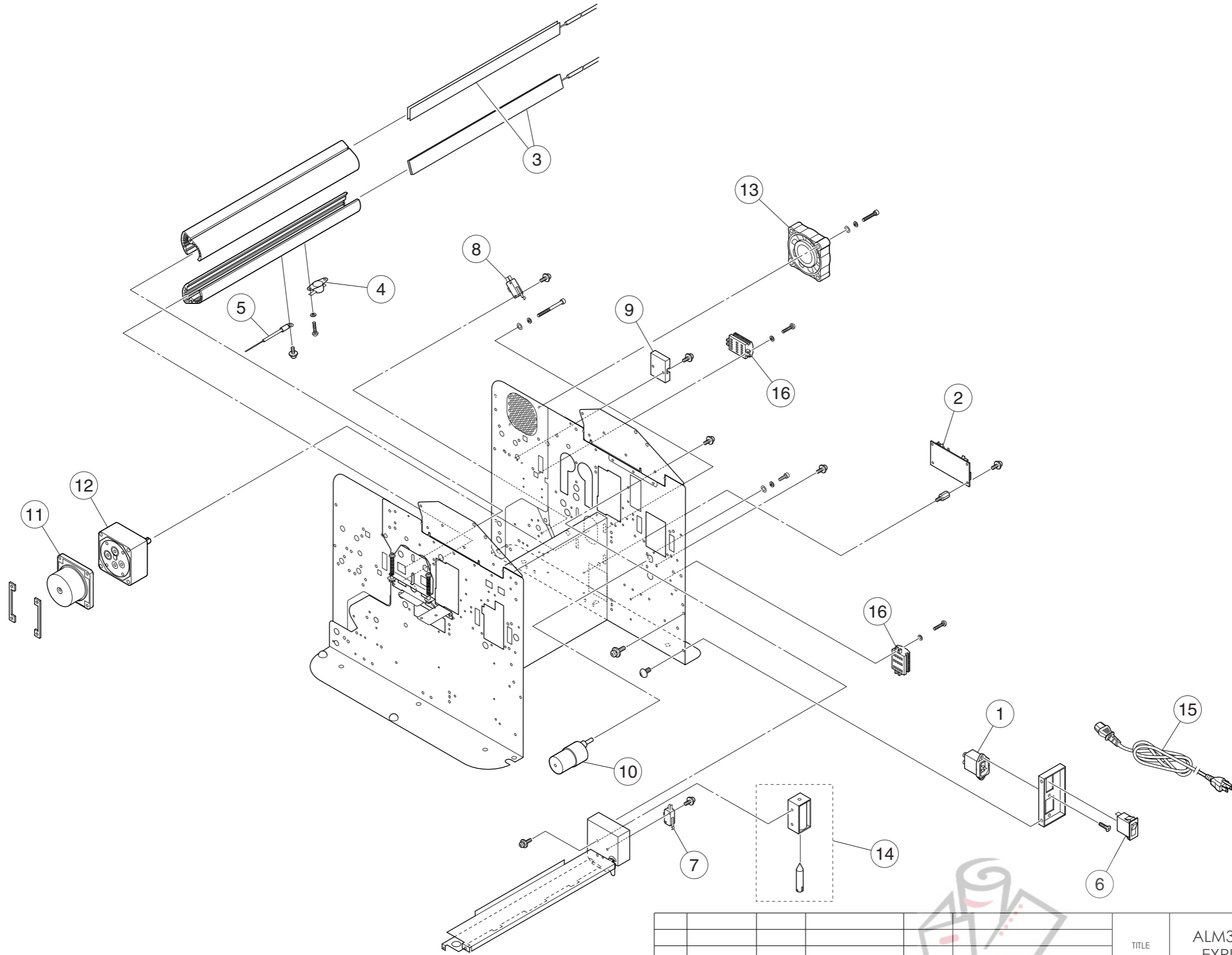
2

3

4

A

B



C

D

E

F

ALM3220(AC120V) Fig.5				
No.	Part No.	Part Name	Qt'	
1	998920	Power Socket	1	
2	998921	5V Regulator	1	
3	998986	Heater(120V/400W)	2	
4	998924	Thermostat	1	
5	998925	Thermistor	1	
6	998930	Power Switch	1	
7	998931	Cover Switch(SIGNAL)	1	
8	998932	Cover Switch(POWER)	1	
9	998935	SSR	1	
10	998936	Stopper Motor, Trimmer Motor	1	
△3	11	998939	Lamination Motor	1
	12	998938	Lamination Motor Gear Head	1
	13	998940	FAN(Machine)	1
	14	998942	Flap Solenoid	1
	15	998989	Power Cable(US)	1
	16	998944	Terminal	2

REV	DATE	DRAWN	CHECKED	ENG APPR.	COMMENTS	TITLE	SCALE	
						ALM3220(AC120V) EXPLODED VIEW		
						DWG.NO. L111M-U101		
△3	Jan 28,2009	Sato	Sato	Tarumi	Part No. changed.	 FUJIPA Inc.	SHEET 10/10	
△2	Sep 7,2007	Yamamoto	Kiyono	Tarumi	Yamazaki			Redrawn at exploded view.
	Nov 9,2006	Sato	Kiyono	Tarumi	Yamazaki			New Drawing.
REV	DATE	DRAWN	CHECKED	ENG APPR.	COMMENTS	 FUJIPA Inc.		