

GBC C112

Coil Inserter/Crimper

User's Manual



Provided By

MyBinding.com
When Image Matters.

GBC® *Automated Finishing Division*

MODEL CI12 COLOR COIL INSERTER

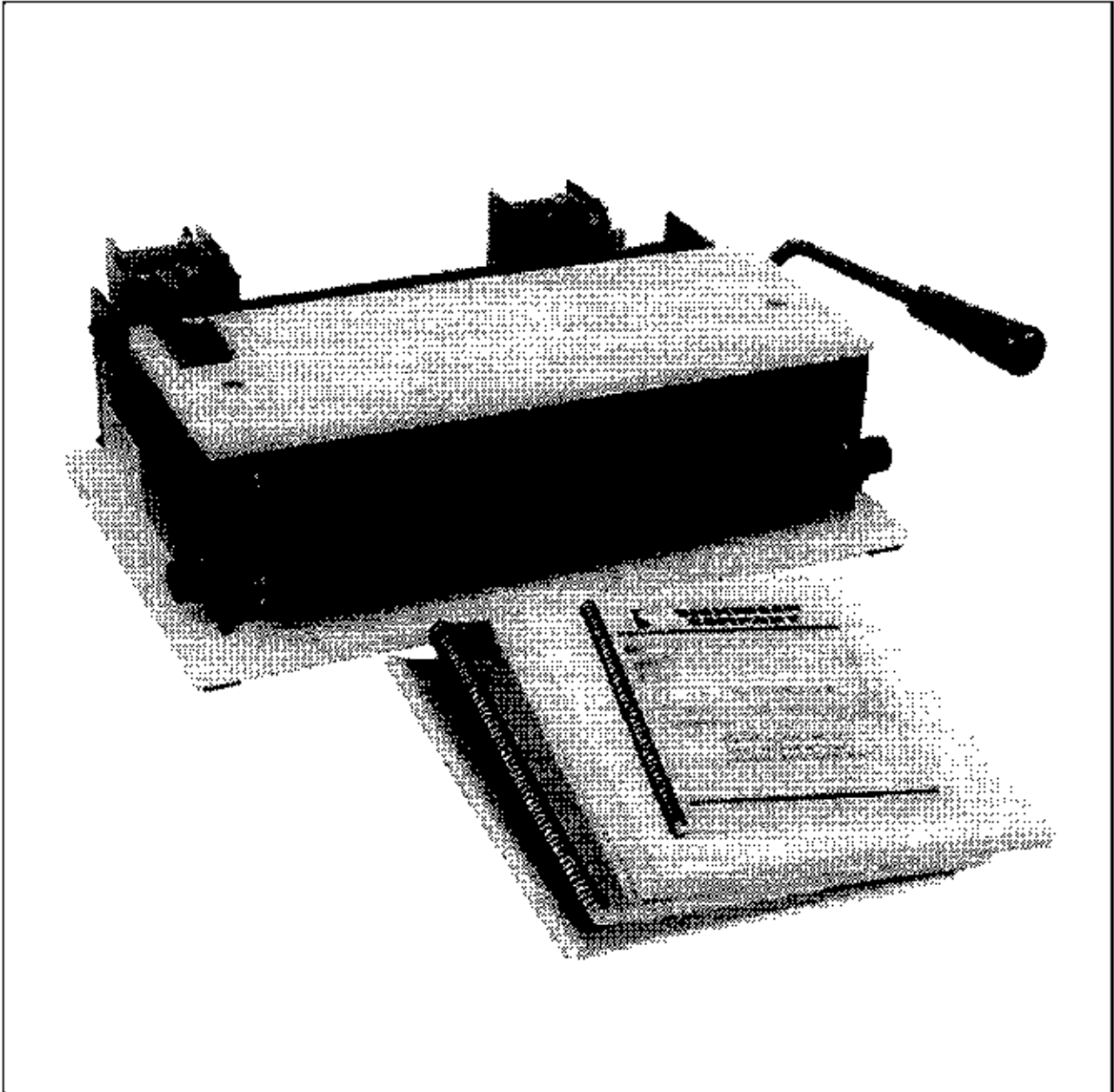

Operating Instructions

MyBinding.com
When Image Matters.

Safety Messages

Your safety as well as the safety of others is important to GBC. In this instruction and on the product are important safety messages. Read these messages carefully.

▲ The safety alert symbol precedes each safety message in this instruction manual. This symbol indicates a potential personal safety hazard that could hurt you or others, as well as cause product damage or property damage.

The following pictorials are found on the product:



This means that a pinch hazard exists between two moving parts. Keep hands and fingers away.



This means an electrical shock hazard exists if covers, enclosures or guards are removed and internal parts become accessible. ALWAYS refer servicing to qualified GBC service personnel.

▲ CAUTION
For continued protection against risk of fire, replace only with same type and rating of fuse.

▲ ATTENTION
Pour une protection continue contre un risque d'incendie, remplacer seulement avec un fusible du même genre et de même valeur.

This means that a risk of fire exists if the line fuse is not replaced by the same type and rating fuse. The fuse rating was selected to provide maximum protection and longevity to the product. ALWAYS replace with same fuse type and rating.

▲ FOR YOUR SAFETY:

- Do not connect this product to electrical power or attempt to operate it before you read this operating instructions and have been fully trained to operate this product.
- Do not grab or slide your fingers, hands, or other body parts on the knife assembly.
- Keep hands, long hair, neckties, necklaces and other loose articles away from rollers.
- Do not place this product on an unstable stand, cart, or surface. The product may fall and hurt you. If you use a cart, move the product and cart carefully. Quick stops, rough or uneven surfaces, and excessive force may cause the product and cart to overturn and hurt you.
- Do not insert objects or spill liquids into the product. They may contact dangerous voltage or short out components that may result in fire or electric shock.
- Only connect this product to the electrical supply shown in the machine specification section of this operating instruction and the serial/rating label.
- For pluggable equipment, the socket outlet shall be installed near the equipment and shall be easily accessible.
- Do not alter the plug on the end of the cord set provided with this product. It was selected for your safety. Connect the plug only to a matching receptacle. If you do not have such a receptacle, contact a qualified electrician to have one installed.
- Turn the product 'Off' ("O" position) at the end of the day.
- Unplug the product before moving it. Unplug the product when it will not be in use for an extended period of time.
- Do not attempt to service this product. Contact an authorized GBC service representative if any of the following conditions listed below are encountered:
 - Damaged plug or frayed power cord.
 - If liquid has been spilled into the product.
 - If the product has been exposed to rain or water.
 - If the product has been dropped, bumped or dented.
 - If the product does not operate normally when following the operating instructions.

Instructions

To bind with Color Coil using the CI 12:

1. Plug machine into 115V AC.
2. Turn power switch ON. ("I" position)
3. Start coil by hand into the first 3 holes in the book.
4. Apply pressure with thumbs on top of document.
5. Position started coil in book against rollers. (See figure 1)
6. Position book with inserted coil on top shelf with coil into knives. (See figure 3)
7. Depress handle to cut and crimp ends.

Small Roller Adjustment

Adjust the small roller by pulling out on the pull knobs (See figure 2).

The location of the roller depends upon the inside diameter of the coil.

Adjust as follows:

1. If you are using a coil size from 5mm to 13mm adjust the small roller to its highest position.
2. If you are using a coil size from 14mm to 22mm adjust the small roller to its center position.
3. If you are using a coil size 25mm and larger adjust the small roller to its lowest position.

CI 12 Knife Selection

The CI 12 comes with the small knife assembly and the standard knife assembly. The small knife assembly is to be used for coil I.D.'s from 5mm to 8mm.

The standard knife assembly is to be used for coil I.D.'s 10 mm and above.

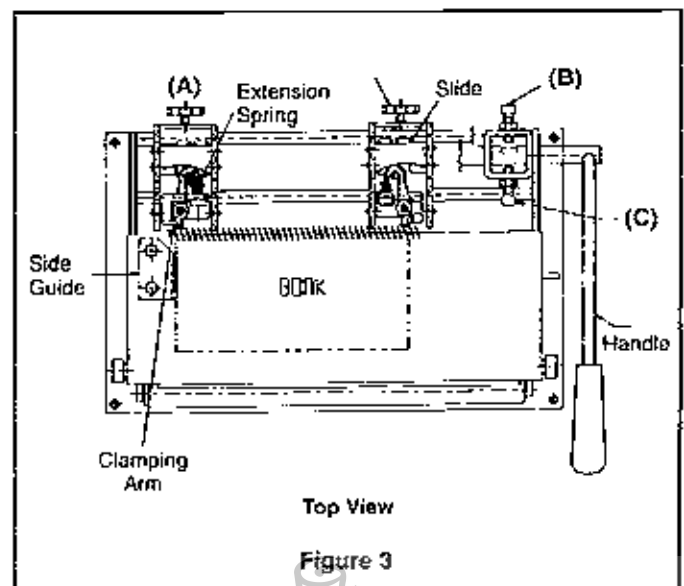
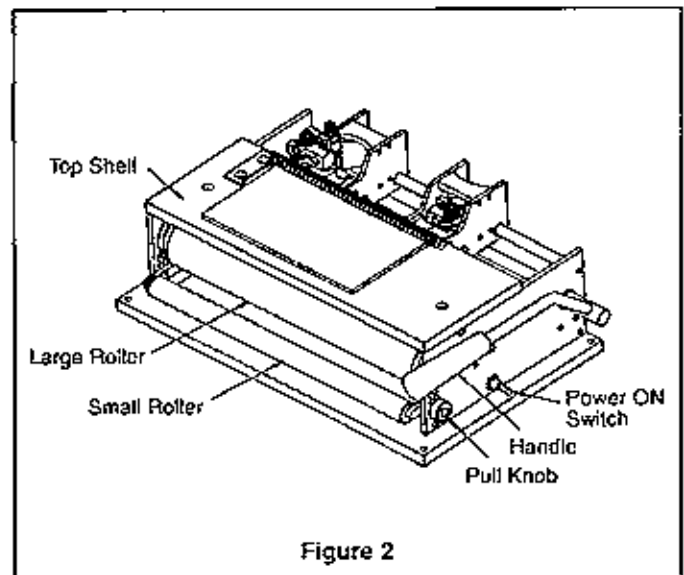
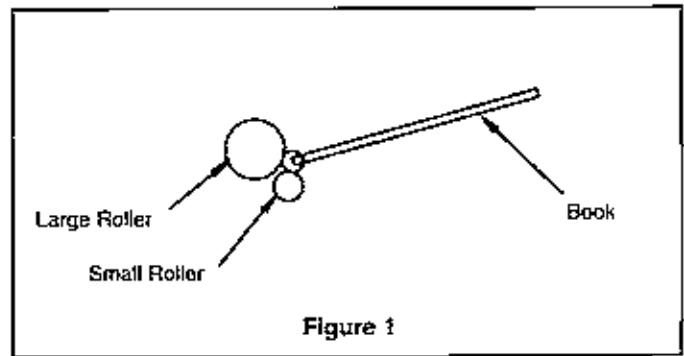

CI 12 Knife Adjustments

With the book against the side guide, loosen the knobs to adjust the right and left knife assemblies (A) so that the slot in the knives lines up with coil in the first and last holes of book. Tighten the knobs after positioning.

Using a 3/16" allen wrench adjust the rear screw (B) so that the slide is not hitting the clamping arm or the extension spring. (factory adjusted)

Using a 3/16" allen wrench adjust the front screw (C) to give the handle slight tension. (factory adjusted)

Using a 1/16" allen wrench, adjust the knife with set screws (D) so that the clamping arm (E) pinches the coil with the knife blade approximately 1/32" away from the coil. (factory adjusted)

Using a 3/16" allen wrench adjust the knife assembly height (F) so that the tuck portion of the knife is at the center of the coil.

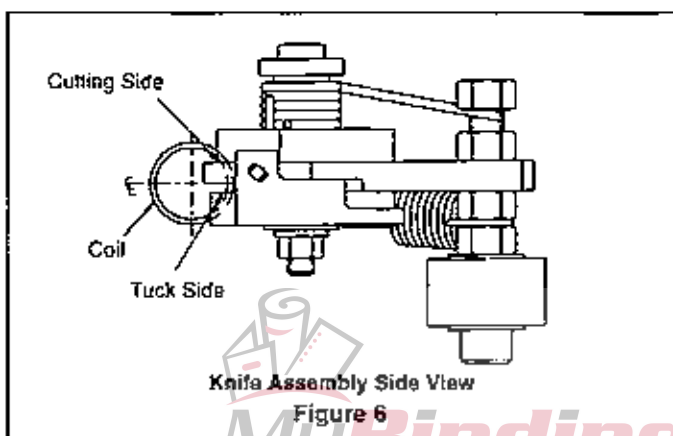
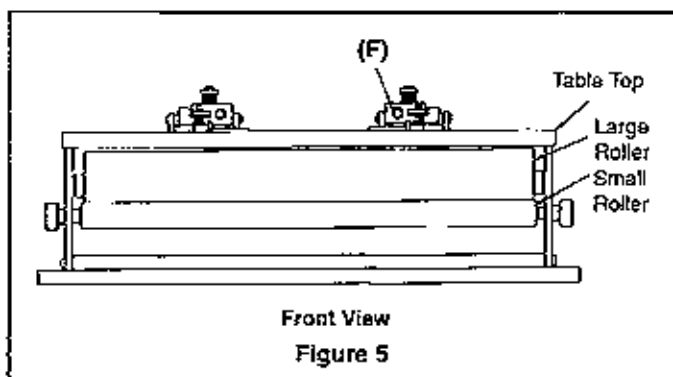
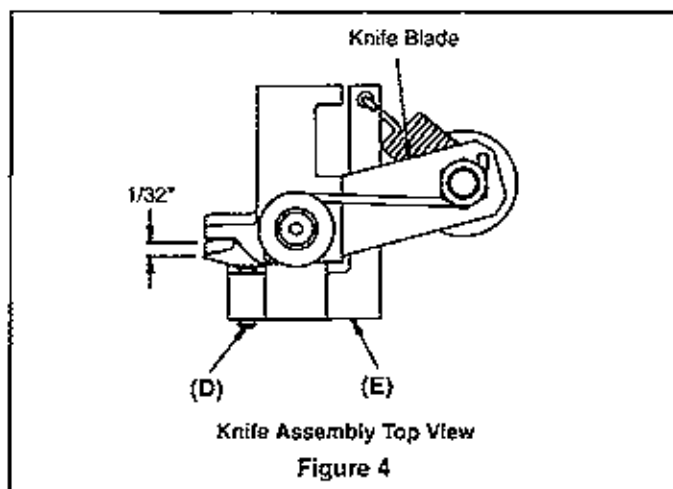
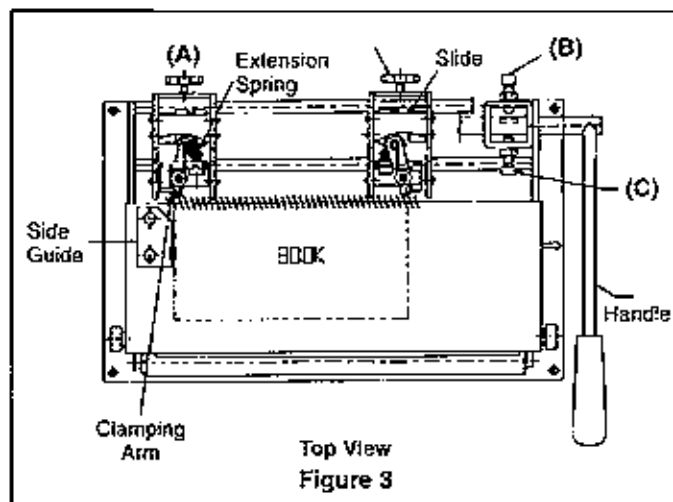

Troubleshooting:

In the case that either the left and/or the right crimper does not cut, please note these minor adjustments:

Problem:	Solution		
	Left crimper	&/or	Right crimper
cutting but not crimping	move down		move up
crimping but not cutting	move up		move down

Note: Body of knife should always be below table top level.

Machine Specifications

Voltage: 115V
Phase: Single

Hertz: 60 Hz
Amps: 2.2

GBC Automated Finishing Division

One GBC Plaza • Northbrook, IL6062
P.O. Box 215230 • Auburn Hills, MI 48321-2530