

522/523/568/569 - LM'S

BOTTOM HEATER ASSEMBLY FIGURE 8.0.4

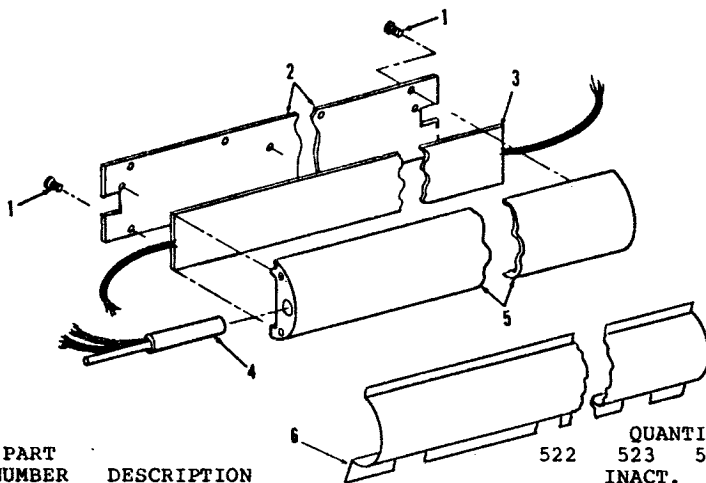

ITEM NUMBER	PART NUMBER	DESCRIPTION	QUANTITY			
			522	523	568	569
				INACT.		
	1140028	HEATER ASSEMBLY, TOP, 9 INCH, 115 VOLT (SEE 20, FIGURE 8.0.2 FOR REFERENCE TO NEXT HIGHER ASSEMBLY)	1			
	1140112	HEATER ASSEMBLY, TOP, 9 INCH, 230 VOLT (SEE 20, FIGURE 8.0.2 FOR REFERENCE TO NEXT HIGHER ASSEMBLY)		1		
	1140030	HEATER ASSEMBLY, TOP, 27 INCH, 115 VOLT (SEE 20, FIGURE 8.0.2 FOR REFERENCE TO NEXT HIGHER ASSEMBLY)			1	
	1140114	HEATER ASSEMBLY, TOP, 27 INCH, 230 VOLT (SEE 20, FIGURE 8.0.2 FOR REFERENCE TO NEXT HIGHER ASSEMBLY)				1
1	1902643	SCREW, FLAT HD, NO. 10-24 X 3/8" LG	6	6	14	14
2	1140094	COVER, HEATER	1	1		
2	1140127	COVER, HEATER			1	1
3	1140095	HEATER ELEMENT 16.5 OHMS (NOM).	1			
3	1140110	HEATER ELEMENT 60.5 OHMS (NOM).		1		
3	1140128	HEATER ELEMENT 11 OHMS (NOM).			1	
3	1140129	HEATER ELEMENT 40.3 OHMS (NOM).				1
4	1140098	SWITCH, THERMOSTAT.	1	1	1	1
5	1140100	HEATER SHELL, TOP	1	1		
5	1140132	HEATER SHELL, TOP			1	1
6	1203065	HEATER BLANKET, TEFLON.	1	1	1	1

**TOP HEATER ASSEMBLY
FIGURE 8.0.3**

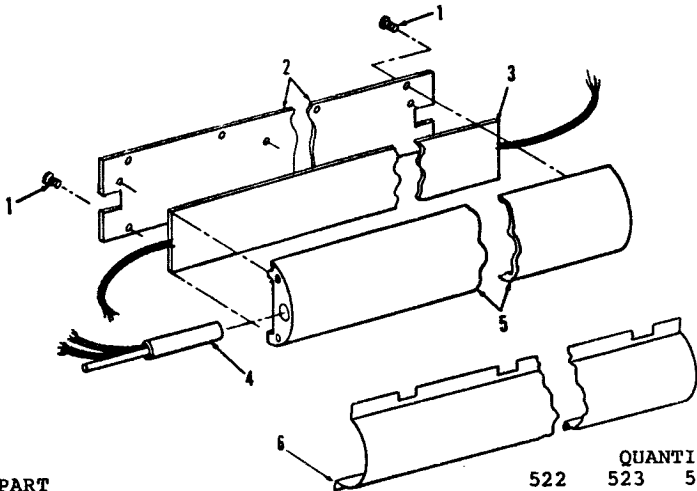

ITEM NUMBER	PART NUMBER	DESCRIPTION	QUANTITY			
			522	523	568	569
				INACT.		
	1140027	HEATER ASSEMBLY, TOP, 9 INCH, 115 VOLT (SEE 19, FIGURE 8.0.2 FOR REFERENCE TO NEXT HIGHER ASSEMBLY)				
	1140111	HEATER ASSEMBLY, TOP, 9 INCH, 230 VOLT (SEE 19, FIGURE 8.0.2 FOR REFERENCE TO NEXT HIGHER ASSEMBLY)	1			
	1140029	HEATER ASSEMBLY, TOP, 27 INCH, 115 VOLT (SEE 19, FIGURE 8.0.2 FOR REFERENCE TO NEXT HIGHER ASSEMBLY)		1		
	1140113	HEATER ASSEMBLY, TOP, 27 INCH, 230 VOLT (SEE 19, FIGURE 8.0.2 FOR REFERENCE TO NEXT HIGHER ASSEMBLY)			1	
1	1902643	SCREW, FLAT HD, NO. 10-24 X 3/8" LG				1
2	1140094	COVER, HEATER	6	6	14	14
2	1140127	COVER, HEATER	1	1		
3	1140095	HEATER ELEMENT 16.5 OHMS (NOM).			1	1
3	1140110	HEATER ELEMENT 60.5 OHMS (NOM).	1	1		
3	1140128	HEATER ELEMENT 11 OHMS (NOM).			1	
3	1140129	HEATER ELEMENT 40 OHMS (NOM).				1
4	1140098	SWITCH, THERMOSTAT.	1	1	1	1
5	1140100	HEATER SHELL, TOP	1	1		
5	1140132	HEATER SHELL, TOP			1	1
6	1203065	HEATER BLANKET, TEFLON.	1	1	1	1

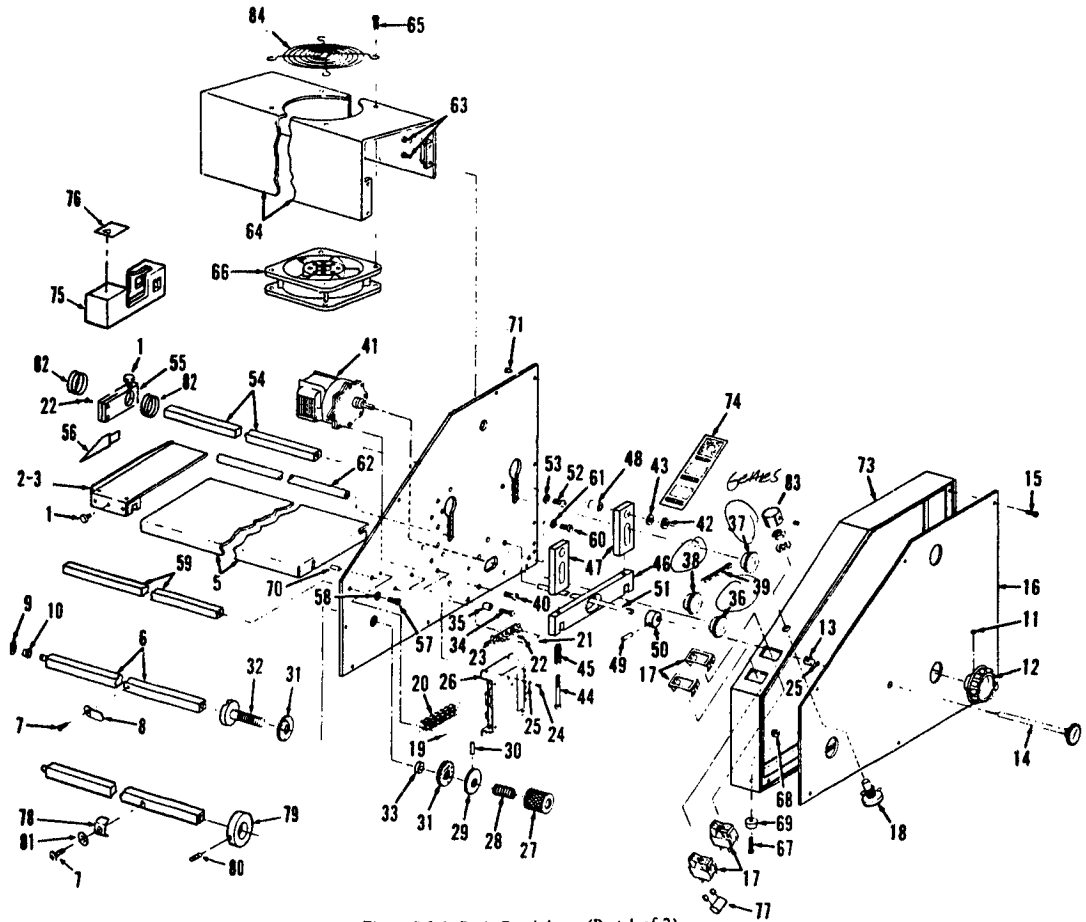

Figure 8.0.1 Basic Breakdown (Part 1 of 2)

LAMINATOR BASIC BREAKDOWN (PART 1 OF 2)
FIGURE 8.0.1

ITEM NUMBER	PART NUMBER	DESCRIPTION	QUANTITY			
			522	523 INACT.	568	569
1	1140078	KNOB, KNURLED 10-24 X 5/8" LG	4	4	4	4
2	1140328	SIDE GUIDE, R.H.	1	1	1	1
3	1140327	SIDE GUIDE, L.H.	1	1	1	1
5	1140076	TABLE, FEED	1	1		
5	1140120	TABLE, FEED			1	1
6	1140043	SHAFT, SUPPLY ROLL.	2	2		
6	1140117	SHAFT, SUPPLY ROLL.			2	2
7	1902803	SCREW, PHIL PAN HD, NO. 6-32 X 1/4" LG.	2	2	6	6
8	1140044	DOG EAR	2	2	6	6
9	1931607	RING, RETAINING	2	2	2	2
10	1952027	BEARING :	2	2	2	2
11	1900001	SETSCREW.	1	1	1	1
12	1140053	KNOB, PRESSURE, RELEASE/APPLY	1	1	1	1
13	1140159	RETAINER, THERMOMETER	2	2	2	2
14	1140052	THERMOMETER C	2	2	2	2
14	1140264	THERMOMETER F	2	2	2	2
15	1902803	SCREW, PHIL PAN HD, NO. 6-32 X 1/4" LG.	5	5	5	5
16	1140033	PANEL, RIGHT SIDE	1	1	1	1
17	1140018	SWITCH, LIGHTED, SPST	4		4	
17	1140163	SWITCH, DPST.		2		2
18	1140453	POTENTIOMETER, SPEED CONTROL.	1			
18	1140139	POTENTIOMETER, SPEED CONTROL.		1		1
18	1154836	POTENTIOMETER, SPEED CONTROL.			1	
19	1902815	SCREW, PHIL PAN HD, NO. 6-32 X 1/2" LG.	2	2	4	4
20	1142469	TERMINAL BOARD.	1	1	2	2
21	1140023	FUSE, 5 AMP	1	1	1	1
22	1902818	SCREW, PHIL PAN HD, NO. 6-32 X 3/8" LG.	5	5	5	5
23	1140021	FUSEHOLDER.	1	1	1	1
24	1902818	SCREW, PHIL PAN HD, NO. 6-32 X 3/8" LG.	2	2	2	2
25	1140165	WASHER, FLAT.	4	4	4	4
26	1140024	SPEED CONTROL ASSEMBLY.	1			
26	1140109	SPEED CONTROL ASSEMBLY.		1		1
26	1140160	SPEED CONTROL ASSEMBLY, AND POTENTIOMETER			1	
27	1140036	KNOB, FILM TENSION.	2	2	2	2
28	1140037	SPRING, FILM TENSION.	2	2	2	2
29	1140038	WASHER, FILM TENSION.	2	2	2	2
30	1929206	PIN, ROLL, 1/8X1" LG.	2	2	2	2
31	1140040	DISC, FILM TENSION.	4	4	4	4
32	1140042	HOLDER, SUPPLY ROLL SHAFT	2	2	2	2
33	1140091	BUSHING	2	2	2	2
34	1902852	SCREW, PHIL PAN HD, NO. 10-24 X 1" LG	4	4	4	4
35	1140072	SPACER, PHENOLIC, LONG.	4	4	4	4

LAMINATOR BASIC BREAKDOWN (PART 1 OF 2) (Continued)

FIGURE 8.0.1

ITEM NUMBER	PART NUMBER	DESCRIPTION	QUANTITY			
			522	523 INACT.	568	569
36	1140055	SPROCKET, MOTOR, 21 TOOTH . .	1	1		
*36	1140306	SPROCKET, MOTOR, 15 TOOTH . .			1	1
37	1140056	SPROCKET, LOWER PULL ROLLER, 20 TOOTH.	1	1	1	1
38	1140057	SPROCKET, LOWER NIP ROLLER, 21 TOOTH.	1	1	1	1
39	1140058	CHAIN, 1/4 PITCH.	1	1		
*39	1140049	CHAIN, 25 PITCH, 85 LINK. . .			1	1
40	1140069	SCREW, PHIL FLAT HD, NO. 10-32 X 5/8" LG	4	4	4	4
41	1142468	MOTOR, DC	1	1		
41	1140065	MOTOR, DC			①	1
42	1931604	RING, RETAINING	4	4		
43	1925033	WASHER, FLAT, STEEL	4	4	2	2
44	1140167	BOLT, SOCKET HEAD, 5/16-18 X 2-1/2" LG	4	4	4	4
45	1140064	SPRING, ROLLER PRESSURE . . .	4	4	4	4
46	1140062	FOLLOWER, CAM	2	2	2	2
47	1140063	BLOCK, BEARING.	2	2	2	2
48	1140068	BUSHING, STRAIGHT	2	2	2	2
49	1140060	PIN, ROLL	2	2	2	2
50	1140059	CAM	2	2	2	2
51	1140061	SHAFT, CAM.	1	1		
51	1140118	SHAFT, CAM.			1	1
52	1902824	SCREW, PHIL PAN HD, NO. 10-32 X 5/8" LG	2	2	2	2
53	1925803	WASHER, LOCK, INTERNAL TOOTH, NO. 10.	2	2	2	2
54	1140170	BAR, SLITTER.	1	1		
54	1140171	BAR, SLITTER.			1	1
55	1140172	HOLDER, SLITTER BLADE	2	2	2	2
56	1140173	BLADE, SLITTER.	2	2	2	2
57	1902851	SCREW, PHIL PAN HD, 1/4-20 X 1/2" LG.	2	2	2	2
58	1925804	WASHER, LOCK, INTERNAL TOOTH, 1/4"	2	2	2	2
59	1140074	BAR, PAPER GUIDE.	1	1		
59	1140119	BAR, PAPER GUIDE.			1	1
60	1902851	SCREW, PHIL PAN HD, 1/4-20 X 1/2" LG.	2	2	2	2
61	1925804	WASHER, LOCK, INTERNAL TOOTH, 1/4"	2	2	2	2
62	1140083	BAR, CROSS.	1	1		
62	1140122	BAR, CROSS.			1	1
63	1902803	SCREW, PHIL PAN HD, NO. \6-32 X 1/4" LG.	8	8	8	8
64	1142500	HOUSING, FAN ASSY	1	1		
64	1154266	HOUSING, FAN ASSY			1	1

LAMINATOR BASIC BREAKDOWN (PART 1 OF 2) (Continued)

FIGURE 8.0.1

ITEM NUMBER	PART NUMBER	DESCRIPTION	522	QUANTITY		
				523 INACT.	568	569
65	1902854	SCREW, PHIL PAN HD, NO. 10-24 X 3/8" LG	4	4	16	16
66	1154266	FAN (115 VOLT).	1		4	
66	1140108	FAN (230 VOLT).		1		4
67	1902853	SCREW, ROUND HEAD, NO. 10-24 X 5/8" LG	4	4	4	4
68	1926703	NUT, HEX, NO. 10-24	4	4	4	4
69	1140048	FOOT, RUBBER.	4	4	4	4
70	1140080	PIN, ROLL, FEED TABLE SUPPORT	4	4	4	4
71	1929500	RIVET, POP, 1/8 X 5/16" LG. .	9	9	9	9
73	1142526	LH SIDE RAIL & SIDE SUPPORT (FIGURE 8.0.2 #38).	1			
73	1142549	RH SIDE RAIL & SIDE SUPPORT .	1			
74	1140179	DECAL (RIGHT HAND), FAN/MOTOR	1	1	1	1
75	1140323	SAFETY HOUSING-SLITTER. . . .	2	2	2	2
76	1140051	CAUTION LABEL-SLITTER	2	2	2	2
77	1142465	VARISTOR ASSEMBLY		1		1
77	1142466	VARISTOR ASSEMBLY	1		1	
78	1131019	CLIP, CORE MOUNTING	2	2	6	6
79	1131018	SUPPLY ROLL BUSHING	2	2	2	2
80	1900070	SETSCREW, DOG POINT, 10-32 X 7/16" LG.	2	2	2	2
81	1925007	WASHER, FLAT, NO. 6	2	2	6	6
82	1140324	SPRING.	4	4	4	4
83	1140454	KNOB, SPEED CONTROL	1			
84	1140225	FINGER GUARD, FAN	1	1		

* PART OF 1140305 DRIVE MOTOR SERVICE KIT (T.S.B. 141)

LAMINATOR BASIC BREAKDOWN (PART 2 OF 2)

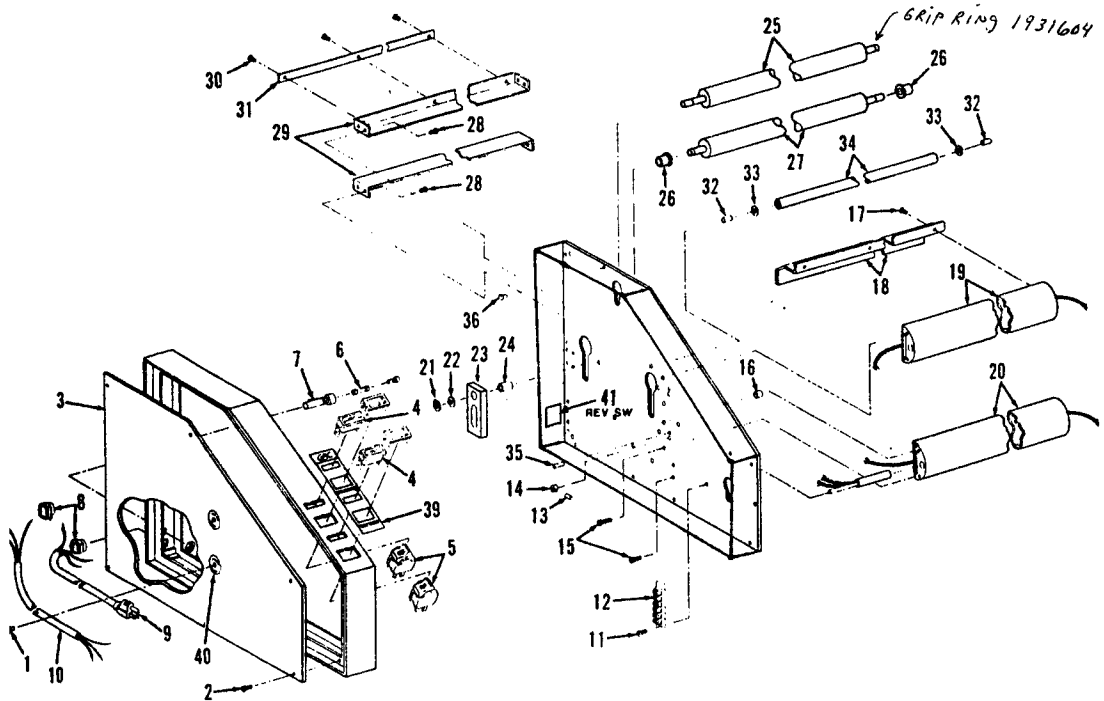

Figure 8.0.2 Basic Breakdown (Part 2 of 2)

FIGURE 8.0.2

ITEM NUMBER	PART NUMBER	DESCRIPTION	522	QUANTITY		569
				523	568	
				INACT.		
1	1140161	KNOB, THERMOSTAT SWITCH	2	2	2	2
2	1902803	SCREW, PHIL PAN HD, NO. 6-32 X 1/4" LG.	5	5	5	5
3	1140085	PANEL, LEFT SIDE.	1	1	1	1
4	1140019	LAMP, INDICATOR (115 VOLT). . . .	2		2	
4	1140162	LAMP, INDICATOR (230 VOLT). . . .		2		2
5	1140018	SWITCH, LIGHTED, SPST	2		2	
5	1140163	SWITCH, DPST.		2		2
6	1140177	FUSE, 20 AMP.	1			
6	1140022	FUSE, 10 AMP.		1		
6	1140031	FUSE, 25 AMP.			1	
6	1140277	FUSE, 15 AMP.				1
7	1140016	FUSEHOLDER.	1	1	1	1
8	1952414	STRAIN RELIEF	1	1		1
8	1952416	STRAIN RELIEF, HEYCO.			1	
9	1142506	POWER CORD ASSEMBLY	1			
9	1142507	POWER CORD ASSEMBLY			1	
10	1142508	POWER CORD ASSEMBLY		1		1
11	1902815	SCREW, PHIL PAN HD, NO. 6-32 X 1/2" LG.	2	2	2	2
12	1142467	TERMINAL BOARD.	1	1	1	1
13	1140184 1900082	SETSCREW, SOCKET, NO. 6-32 X 5/8" LG.	2	2	2	2
14	1140103	COLLAR, THERMOSTAT SWITCH	2	2	2	2
15	1902852	SCREW, PHIL PAN HD, NO. 10-24 X 1" LG	4	4	4	4
16	1140099	SPACER, PHENOLIC, SHORT	4	4	4	4
17	1911109	SCREW, PHIL PAN HD, SEMS NO. 6-32 X 1/4" LG.	6	6	8	8
18	1140093	COVER, ROLLER	2	2		
18	1140126	COVER, ROLLER			2	2
19	1140027	HEATER ASSEMBLY (TOP) (SEE FIGURE 8.0.3 FOR DETAILED BREAKDOWN) .	1			
19	1140111	HEATER ASSEMBLY (TOP) (SEE FIGURE 8.0.3 FOR DETAILED BREAKDOWN) .		1		
19	1140029	HEATER ASSEMBLY (TOP) (SEE FIGURE 8.0.3 FOR DETAILED BREAKDOWN) .			1	
19	1140113	HEATER ASSEMBLY (TOP) (SEE FIGURE 8.0.3 FOR DETAILED BREAKDOWN) .				1
20	1140028	HEATER ASSEMBLY (TOP) (SEE FIGURE 8.0.4 FOR DETAILED BREAKDOWN) .	1			
20	1140112	HEATER ASSEMBLY (TOP) (SEE FIGURE 8.0.4 FOR DETAILED BREAKDOWN) .		1		
20	1140030	HEATER ASSEMBLY (TOP) (SEE FIGURE 8.0.4 FOR DETAILED BREAKDOWN) .			1	
20	1140114	HEATER ASSEMBLY (TOP) (SEE FIGURE 8.0.4 FOR DETAILED BREAKDOWN) .				1
21	1140066	RING, RETAINING	2	2	2	2
LAMINATOR BASIC BREAKDOWN (PART 2 OF 2)						

FIGURE 8.0.2

ITEM NUMBER	PART NUMBER	DESCRIPTION	QUANTITY			
			522	523 INACT.	568	569
22	1140067	WASHER, FLAT, STEEL	2	2	2	2
23	1140063	BLOCK, BEARING.	2	2	2	2
24	1140068	BUSHING, STRAIGHT	2	2	2	2
25	1142068	ROLLER.	4	4		
25	1142069	ROLLER, TOP CROWNED ★			2	2
26	1140092	BUSHING, SHOULDERED	4	4	4	4
27	1142070	ROLLER, BOTTOM.			2	2
28	1902803	SCREW, PHIL PAN HD, NO. 6-32 X 1/4"	8	8	8	8
29	1140226	FILM DETECTOR BOT	1	1		
29	1140124	FILM DETECTOR BOT			1	1
30	1929500	RIVET, POP, 1/8 X 5/16" LG.	3	3	5	5
31	1140087	BLADE, TEAR-OFF	1	1		
31	1140123	BLADE, TEAR-OFF			1	1
32	1140091	BEARING, NYLON PEG.	4	4	4	4
33	1925216	WASHER, FLAT, FIBER	4	4	4	4
34	1140089	IDLER, FILM	2	2		
34	1140125	IDLER, FILM			2	2
35	1140039	PIN, ROLL, THERMOSTAT STOP.	2	2	2	2
36	1929500	RIVET, POP, 1/8 X 5/16" LG.	9	9	9	9
39	1140180	DECAL (LEFT HAND) HEATER.	1	1	1	1
40	1140181	DECAL (LEFT HAND) INCREASE/DECREASE	2	2	2	2
41	1142545	REVERSE SWITCH.	1			
	1152604	FUSE REPLACEMENT LABEL (NOT SHOWN)	1	1	1	1
	1142542	REVERSE SWITCH BEZEL (NOT SHOWN)	1			
	1152614	REVERSE SWITCH BEZEL (NOT SHOWN)	1			

DIAMETER OF CROWNED ROLLER TAPERED FROM 1.5"
AT BOTH ENDS TO 1.510" +.005", -.000" AT CENTER