

PRELIMINARY LAMINATOR SERVICE MANUAL

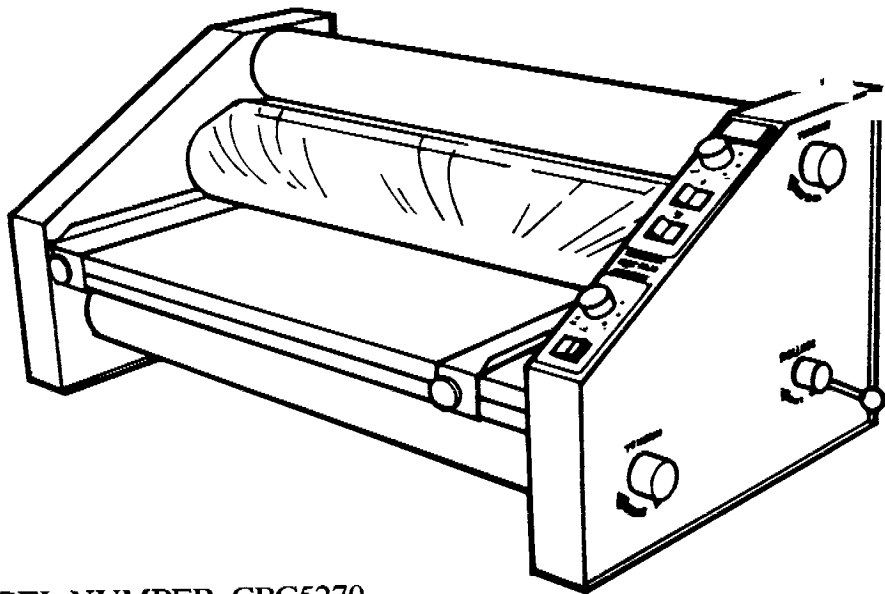

MODEL NUMBER: GBC5270
ASSEMBLY NUMBER: 7100201

10/93



National Service Department

ONE GBC PLAZA
NORTHBROOK, IL 60062
708.272-3700

2.0 SPECIFICATIONS

Standard Power Supply:	230V, 20 amp, 2 wire service plus ground 50/60 Hz, single phase U.S. & Canadian versions equipped with a NEMA 6-20P Attachment plug requires a 6-20R receptacle
Operating Power:	Domestic model: 230 (+6, -10%) VAC, 16 amp, 60 Hz European model: 230 (+6, -10%) VAC, 16 amp, 50 Hz British model: 240 (+6, -10%) VAC, 16 amp, 50 Hz Australian model: 240 (+6, -10%) VAC, 16 amp, 50 Hz
Dimensions:	36 1/4 inches (92 cm) Wide (with handle) 15 3/16 inches (38.5 cm) High 18 9/16 inches (47.1 cm) Deep
Net Weight:	117 Pounds (53.06 kg)
Max Product Width:	27 inches (68.58 cm)
Max Product Thickness:	1/16" (2mm)
Film Capacity:	Maximum Thickness & Length 1.5 mil (40 micron) x 500 ft. (152m) 3.0 mil (75 micron) x 250 ft. (76m) 5.0 mil (127 micron) x 200 ft. (61m) 10.0 mil (254 micron) x 100 ft. (30m)
Maximum Width:	27 inches
Film Roll Winding:	Poly-In
Core Diameter:	1 inch (2.54cm)
Warm-up time:	10-15 minutes
Temperature Range:	200 ^o (94 ^o C) - 350 ^o F (176 ^o C)
Maximum Film Speed:	15 FPM (1.5 mil film)
Plug type:	NE 6-20P

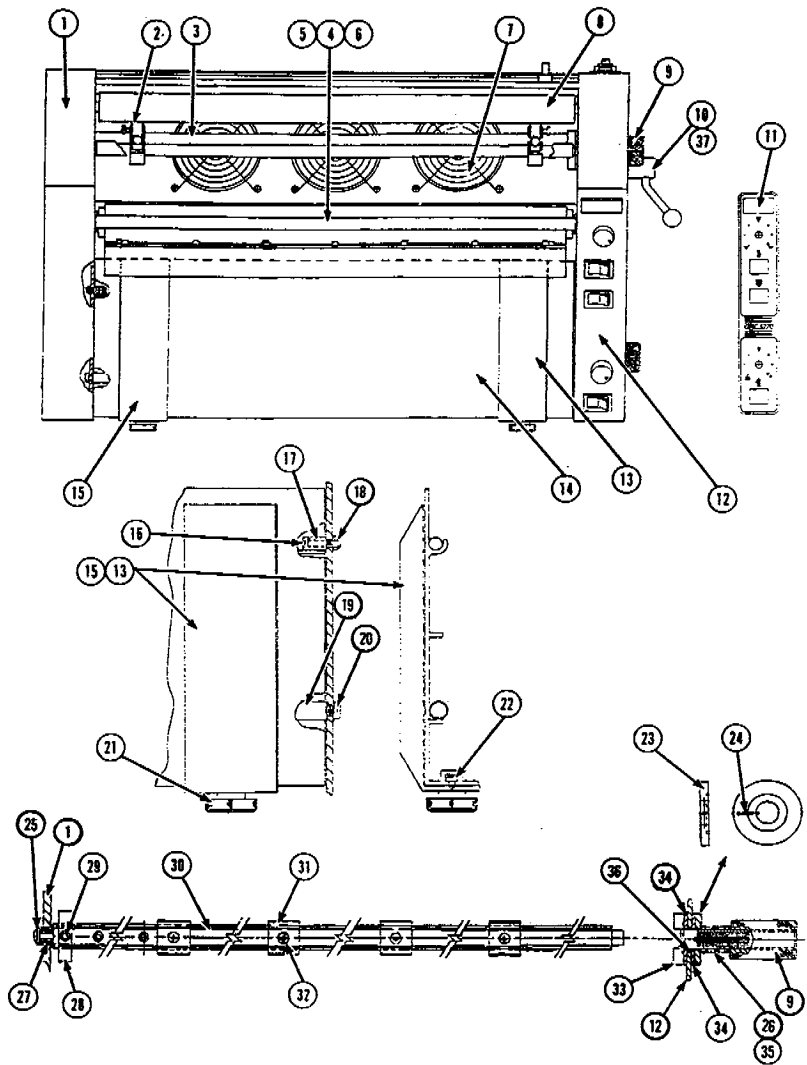

8.0 PARTS LIST

FIGURE 8.1

ITEM	PART NO.	DESCRIPTION	QUANTITY
1	7100277	SIDE RAIL & SIDE SUPPORT ASSY, LH	1
2	REF	SEE FIGURE 6	
3	7100240	SLITTER BAR	1
4	7100260	FILM IDLER	1
5	1140091	PEG BEARING, NYLON	2
6	1925216	WASHER, HARD FIBER	2
7	REF	SEE FIGURE 6	
8	7100261	ROLLER ASSY	4
9	1140036	KNOB, FILM TENSION	2
10	7100258	HANDLE	1
11	6009046	FRONT PANEL LABEL	1
12	7100278	SIDE RAIL & SIDE SUPPORT ASSY. RH	1
13	7100237	FEED GUIDE, RH	1
14	7100276	FEED TABLE	1
15	7100236	FEED GUIDE, LH	1
16	1902822	SCR. PHCR. #10-32 X 1" (MACH)	10
17	1122032	BUSHING - TABLE SUPPORT	2
18	1926803	W'NUT #10 - 32 (KEPS)	6
19	7100271	FEED TABLE, SUPPORT BAR	1
20	1911122	SCR. PPH. W/INT 'W. #1/4 SO X 5/8 S	2
21	7100241	CLAMP KNOB	2
22	1106163	SCR. KNOB HEX. #10.32 X 5/8	2
23	1140038	WASHER	2
24	1929203	PIN-ROLL 1/8φ X 3/4 LG.	2
25	1931607	GRIP RING	2
26	7100254	SPRING, FILM TENSION	2
27	1952027	BEARING	2
28	7100270	SUPPLY ROLL BUSHING	2
29	1900070	SCR.-SH.SET. #10-32 X 7/16 F'DOG	2
30	7100272	MANDREL	2
31	1131019	CLIP - CORE MOUNTING	8
32	1911109	SCR.-P.P.H: W/INT 'W"6.32 X 1.4 SEM	39
33	1140042	HOLDER, SUPPLY ROLL SHAFT	2
34	6210023	DISC, FILM TENSION	4
35	1925160	WASHER-SUPPORT 1 1/8 X 3/4 X 1/32"	4
36	1140041	BEARING	2
37	1900084	SCR. SH. SET. #8-32 X 3/16 (SERR'D)	1
38	6009048	LABEL-REVERSE CAUTION, NOT SHOWN	1
39	6009047	LABEL-SHARP BLADE CAUTION, NOT SHOW	3
40	6009045	LABEL-PULL ROLL CAUTION, NOT SHOWN	1

8.0 PARTS LIST

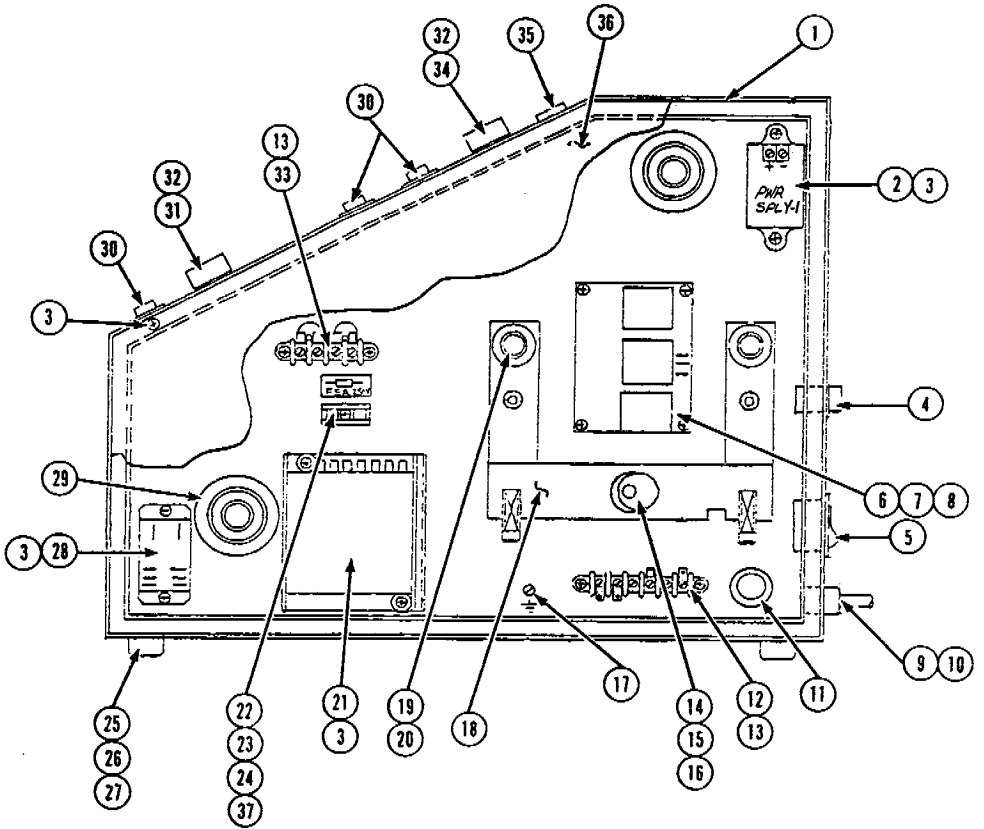

8.0 PARTS LIST

FIGURE 8.2

ITEM	PART NO.	DESCRIPTION	QUANTITY
1	7100278	SIDE RAIL & SIDE SUPPORT ASSY, (RH)	1
2	7100222	POWER SPLY-TEMP. INDICATOR	1
3	1911109	SCR.-P.P.H: W/INT 'W"6.32 X 1.4 SEM	39
4	6202000	SWITCH-REVERSE	1
5	6202001	SWITCH POWER	1
6	7100220	PCB-ASSY (HEATER CTRL.)	1
7	6197001	FIBER BOARD BARRIER	1
8	1902818	SCR.-PHCR-#6-32 X 3/8 (MACH)	4
9	6200018	CORD - 20 AMF 230V	1
10	1952416	STRAIN RELIEF	1
11	1954002	GROMMET-RUBBER 1/2φ 10	1
12	1142467	TERMINAL BLOCK-BOTTOM	1
13	1911121	SCR.-PPH. #6-32 X 1/2 INT'W SEMS	4
15	1140059	CAM	2
16	1929239	ROLL PIN 3/32 X 3/4	2
17	1911123	SCR. #10 - 32 X 1/4"	1
18	REF	SEE FIGURE 6	
19	1931604	GRIP RING	4
	1140118	CAM ROD 27"	1
20	1925033	WASHER, FLAT STEEL	4
21	7100221	PCB-ASSY (SPEED MTR. CTRL.)	1
22	1140023	FUSE 5-AMP	1
23	1140021	FUSE HOLDER	1
24	1963909	LABEL-FUSE	1
25	1120107	RUBBER FOOT	4
26	1926803	W'NUT #10 - 32 (KEPS)	6
27	1902905	SCREW #10-32 X 3/4"	4
28	6204000	RELAY	1
29	REF	SEE FIGURE 1	
30	2602003	SWITCH-PANEL	3
31	6198001	POT.ASSY. 5K (PC8-2)	1
32	7100248	KNOB PANEL	2
33	6197000	TERM. BLOCK - TOP CTRL'S	1
34	6198000	POT. ASSY, 1K (RC8-1)	1
35	7100226	INDICATOR-DIGITAL TEMP.	1
36	7100235	SIDE COVER (RH)	1
37	1902803	SCR. #6 - 32 X 1/4 " MACH.	1

8.0 PARTS LIST

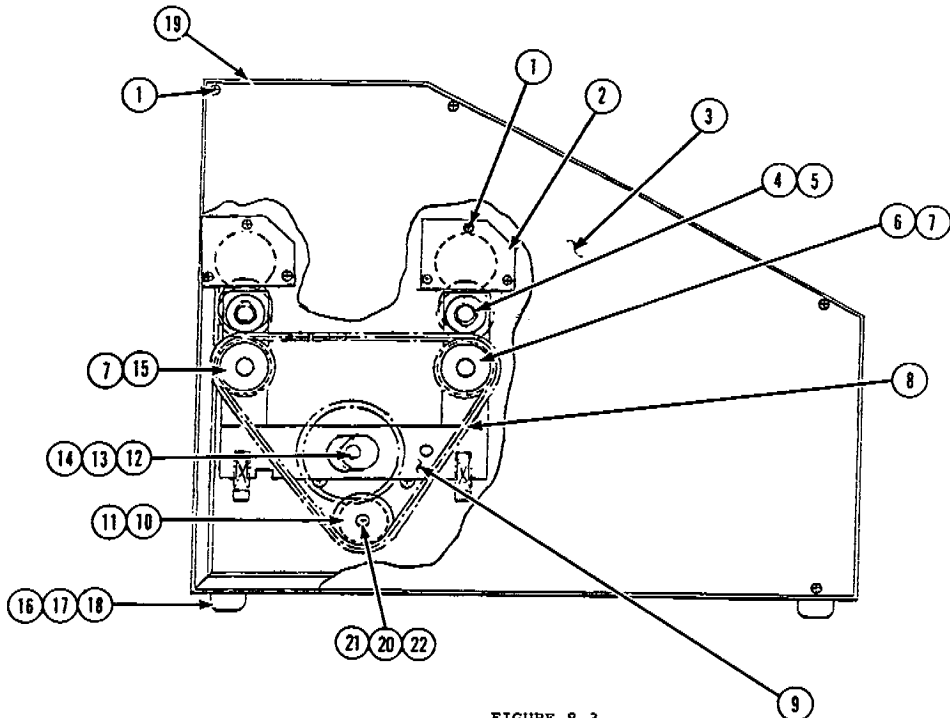

FIGURE 8.3

ITEM	PART NO.	DESCRIPTION	QUANTITY
1	1911109	SCR.-P.P.H: W/INT 'W"6.32 X 1.4 SEM	39
2	7100245	HOLE COVER	4
3	7100234	SIDE COVER (LH)	1
4	1931604	RING, GRIP	4
5	1925033	WASHER, FLAT STEEL	4
6	1140057	SPROCKET, NP ROLLER 21T	1
7	1900063	SCR. SET #1/4 - 20 X 1/2"	2
8	1140049	CHAIN 1/4 PITCH	1
9	REF	SEE FIGURE 6	
10	7100286	SPROCKET MOTOR	1
11	1900032	SCR. SET #1/4 - 20 X 3/8"	1
12	1140118	CAM ROD 27"	1
13	1140059	CAM	2
14	1929239	PIN-ROLL 3/32φ X 3/4 LG	2
15	1140056	SPROCKET, PULL ROLLER 20T	1
16	1120107	RUBBER FOOT	4
17	1926803	W'NUT #10 - 32 (KEPS)	6
18	1902905	SCREW #10-32 X 3/4"	4
19	7100277	SIDE RAIL & SIDE SUPPORT ASSY (LH)	1
20	1902824	SCR. PHCR. - #10-32 X 5/8	2
21	6208000	MOTOR D.C.	1
22	1902602	SCREW P.F.H. 10-32 X 5/8	3

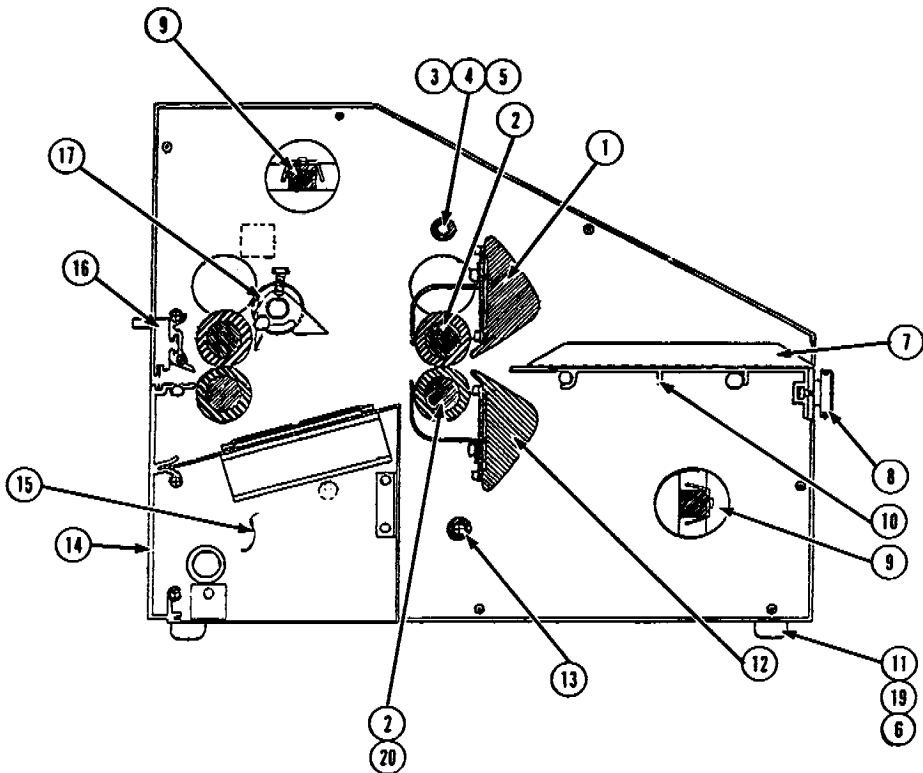
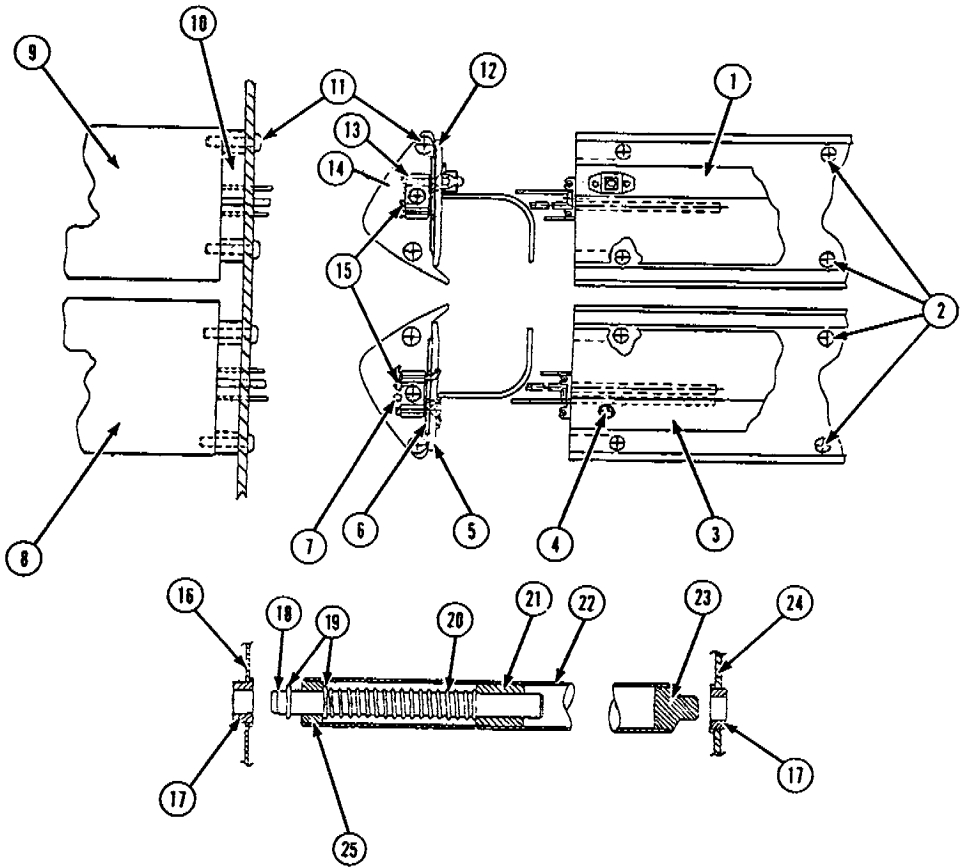

FIGURE 8.4

ITEM	PART NO.	DESCRIPTION	QUANTITY
1	7100250	HEATER SHOE (TOP)	1
2	7100261	ROLLER ASSY	4
3	7100260	FILM IDLER	1
4	1140091	PEG BEARING, NYLON	2
5	1925216	WASHER, HARD FIBER	2
6	1902905	SCR. #10 - 32 X 3/4"	4
7	7100237	FEED GUIDE (R.H.)	1
	7100236	FEED GUIDE (L.H.)	1
8	7100241	CLAMP KNOB	2
	7100273	BACK PLATE (CUTTER ASSY)	1
9	REF	SEE FIGURE 1	
11	1120107	RUBBER FOOT	4
12	7100251	HEATER SHOE (BOTTOM)	1
13	REF	SEE FIGURE 5	
15	REF	SEE FIGURE 6	
16	REF	SEE FIGURE 6	
17	REF	SEE FIGURE 6	
19	1926803	W'NUT #10 - 32 (KEPS)	6
20	1140092	FLANGE BUSHING, (BOTTOM ROLLERS ONL)	4

8.0 PARTS LIST



8.0 PARTS LIST

FIGURE 8.5

ITEM	PART NO.	DESCRIPTION	QUANTITY
1	7100279	ROLLER COVER-REMOVEABLE	1
2	1902643	SCR.-FHCR #10-24 X 3/8 (MACH)	28
3	7100284	ROLLER COVER - BOTTOM	1
4	1911109	SCR.-P.P.H: W/INT 'W"6.32 X 1.4 SEM	39
5	7100883	BOTTOM HEATER COVER	1
6	7100249	HEATER ELEMENT (230V)	2
7	6199000	THERMOL COUPLE 1/8φ	1
8	7100251	HEATER SHOE (BOTTOM)	1
9	7100250	HEATER SHOE (TOP)	1
10	7100265	SPACER-HEATER SHOE	4
11			
12	7100280	TOP HTR COVER ASSY	1
13	7100228	DUAL THERMAL CUT OUT	2
14	1911129	SCR,-PPH W/;INT'W. #10-32 X 5/16	2
15	6199001	THERMISTOR (3/16φ) 30K	2
16	7100277	SIDE RAIL & SIDE SUPPORT ASSY, LH	1
17	1952029	FLANGE BEARING	2
18	1154357	FILM GUIDE, SHAFT	1
19	1930522	GRIP RING	2
20	1154359	SPRING	1
21	1154148	SLEEVE BEARING	1
22	7100259	FILM GUIDE TUBE (BOTTOM)	1
23	1154358	BEARING BOTTOM IDLER	1
24	7100278	SIDE RAIL & SIDE SUPPORT ASSY, RH	1
25	1154340	FILM GUIDE, BEARING	1

8.0 PARTS LIST

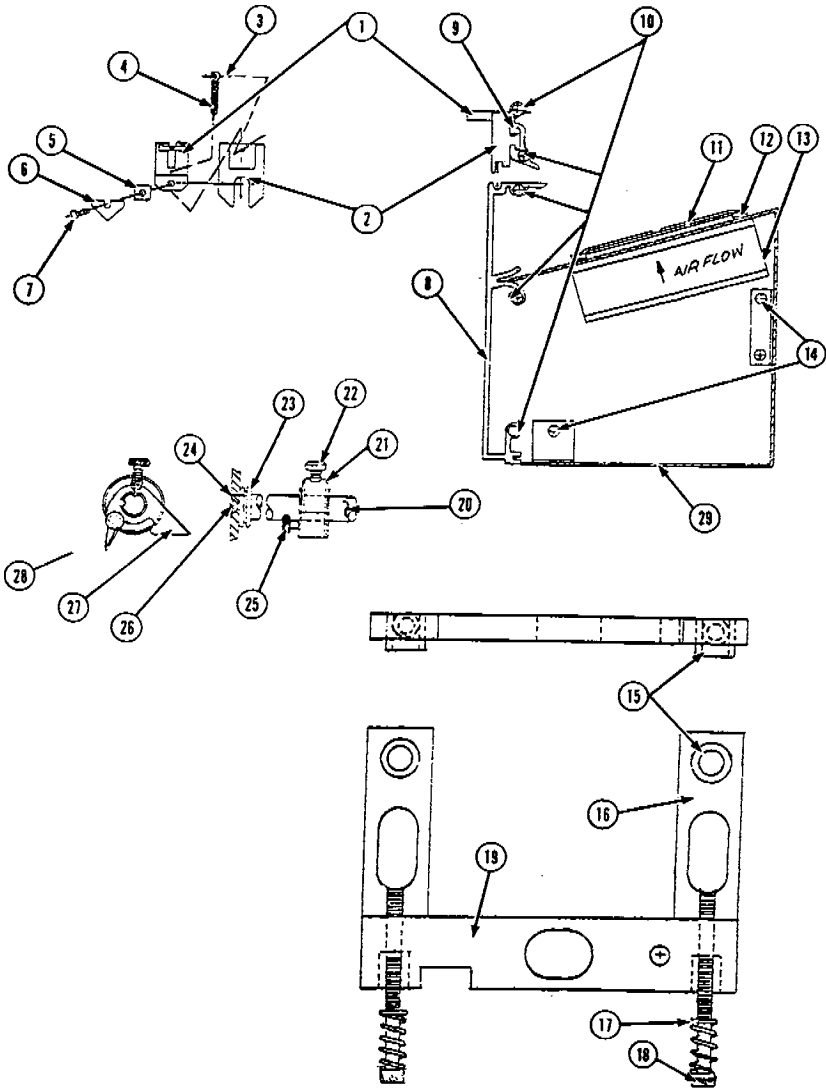

8.0 PARTS LIST

FIGURE 8.6

ITEM	PART NO.	DESCRIPTION	QUANTITY
1	1154139	CUTTER-BLADE HOLDER	1
2	1154138	CUTTER HOUSING	1
3	1929221	PIN-ROLL 1/16φ X 3/8" LG	1
4	1154401	SPRING - EXTENSION	1
5	1931323	FASTENER-U-TYPE	1
6	1154019	CUTTER BLADE	1
7	1900532	SCR.-SH.CAP #6-32 X 1/4	1
8	7100273	BACK PLATE (CUTTER ASSY)	1
9	7100274	CUTTER CHANNEL	1
10	1907802	SCR. PHCR. #8.32 X 2/32 THO.CUT'G	10
11	7100225	FINGER GUARD	3
12	1907822	SCR.-PHCR-W10-24 X 1/2 THO. CUT'G	12
13	6203000	FAN	3
14	1911109	SCR.-P.P.H: W/INT 'W'6.32 X 1.4 SEM	39
15	1140068	BUSHING	4
16	1140063	BEARING BLOCK	4
17	1140064	SPRING	4
18	1900517	SCR.-SH. CAP #1/4'-20 X 1 3/4	4
19	7100285	CAM FOLLOWER	2
20	7100240	SLITTER BAR	1
21	7100218	BLADE HOUSING ASSY	2
22	7100229	THUMB SCR. PLUNGER #1/4 - 20 X 1/2	2
23	1954013	GROMMET-RUBBER	2
24	1900018	SCR.-SET #5-40 X 3/8"	2
25	7100269	THUMB SCR. KNOB #10-32 X 1/2	2
26	1902602	SCREW P.F.H. 10-32 X 5/8	3
27	7100253	SLITTER BLADE GUARD	2
28	1140173	BLADE SLITTER	2
29	7100224	FAN HOUSING ASSY	1