

Figure 8-1 Front View

Item	Part No.	Description	Quantity
1	1156155	Safety Shield (no latch)	1
2	1156118	Shield Label	1
3	1156190	Operator Caution Label	1
4	1156189	Feed Table Label	1
5	1140537	Connector Bar	5
6	1925804	1/4 Washer	18
7	1951969	1/4-20 x 7/8 Cap Head Screw	13
8	1142072	Roller	4
9	See figure 8-11	Top Heat Shoe	1
10	See figure 8-11	Bottom Heat Shoe	1
11	1156166	Spring Latch	1
12	See figure 8-14	Supply Mandrel Assembly	4
13	1154286	Idler Bar Bushing	6
14	1903028	Screw 8-32 x 1/2	4
15	1926802	Nut, 8-32	56
16	1140585	Idler Tube	1
17	1152212	Removeable Idler Shaft	1
18	1152210	Idler Tube	1
19	1931605	Grip Ring	2

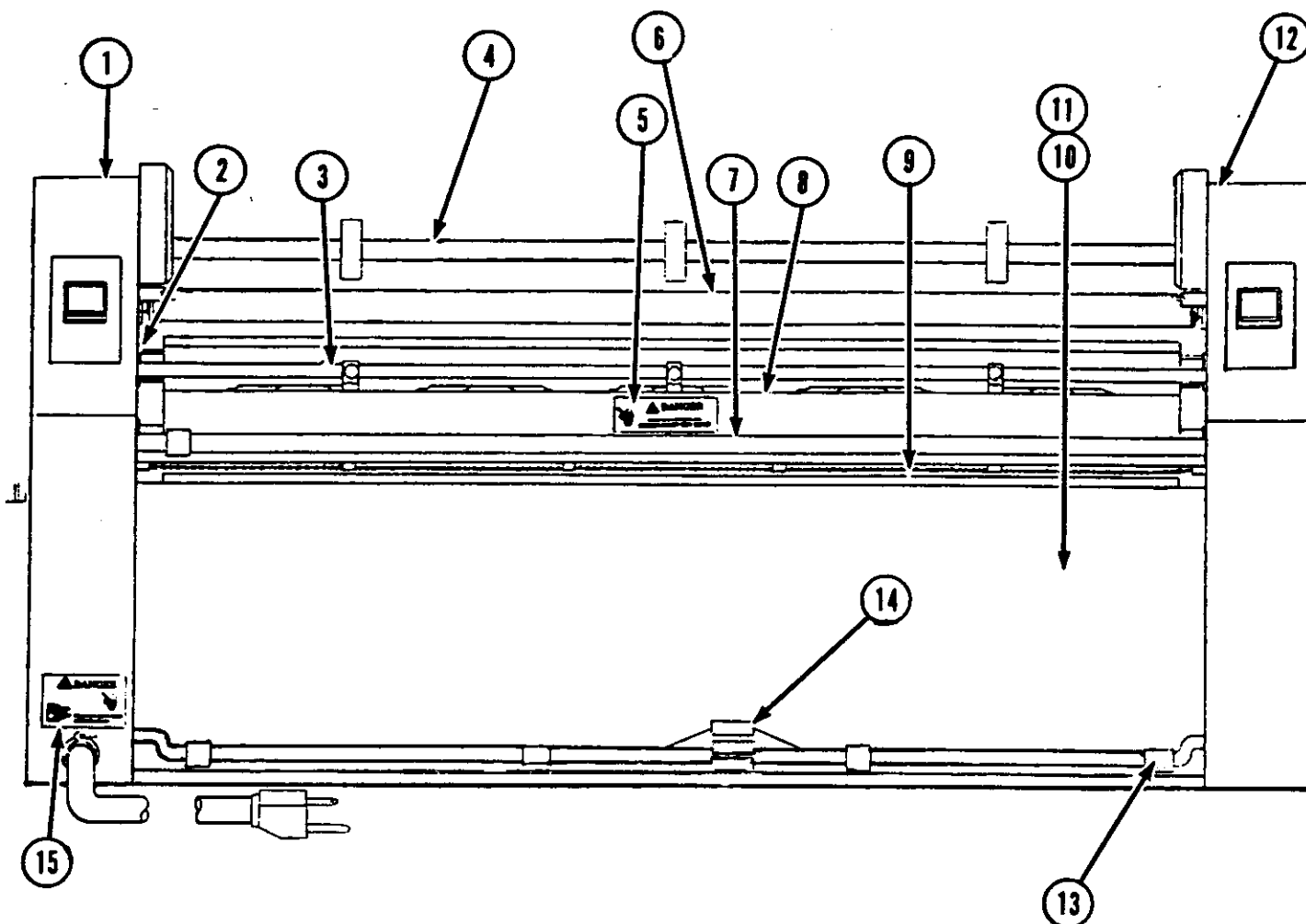

Figure 8-2 Rear View

<u>Item</u>	<u>Part No.</u>	<u>Description</u>	<u>Quantity</u>
1	1154833	Side Support and Rail Assembly,	1
2	1140545	Delrin Bushing (Slitter Bar)	2
3	1140583	Slitter Blade Support Bar	1
4	See Figure 8-14	Supply Mandrel Assembly	2
5	1156187	Fan Housing Label	1
6	See Figure 8-1	Removeable Idler Assembly	1
7	1140537	Connector Bar	5
8	1152261	Top Fan Housing Assembly	1
9	See Figure 8-8	Anti-Static Bar Assembly	1
10	1152406	Back Cover	1
11	1902836	Screw; 10-32 x 1/4	4
12	1154832	Side Support & Rail Assembly, Le	1
13	1931045	Self Adhesive Cable Clamp	4
14	1152291	3/16 Splice Connector	9
15	1156191	Power Supply Label	1

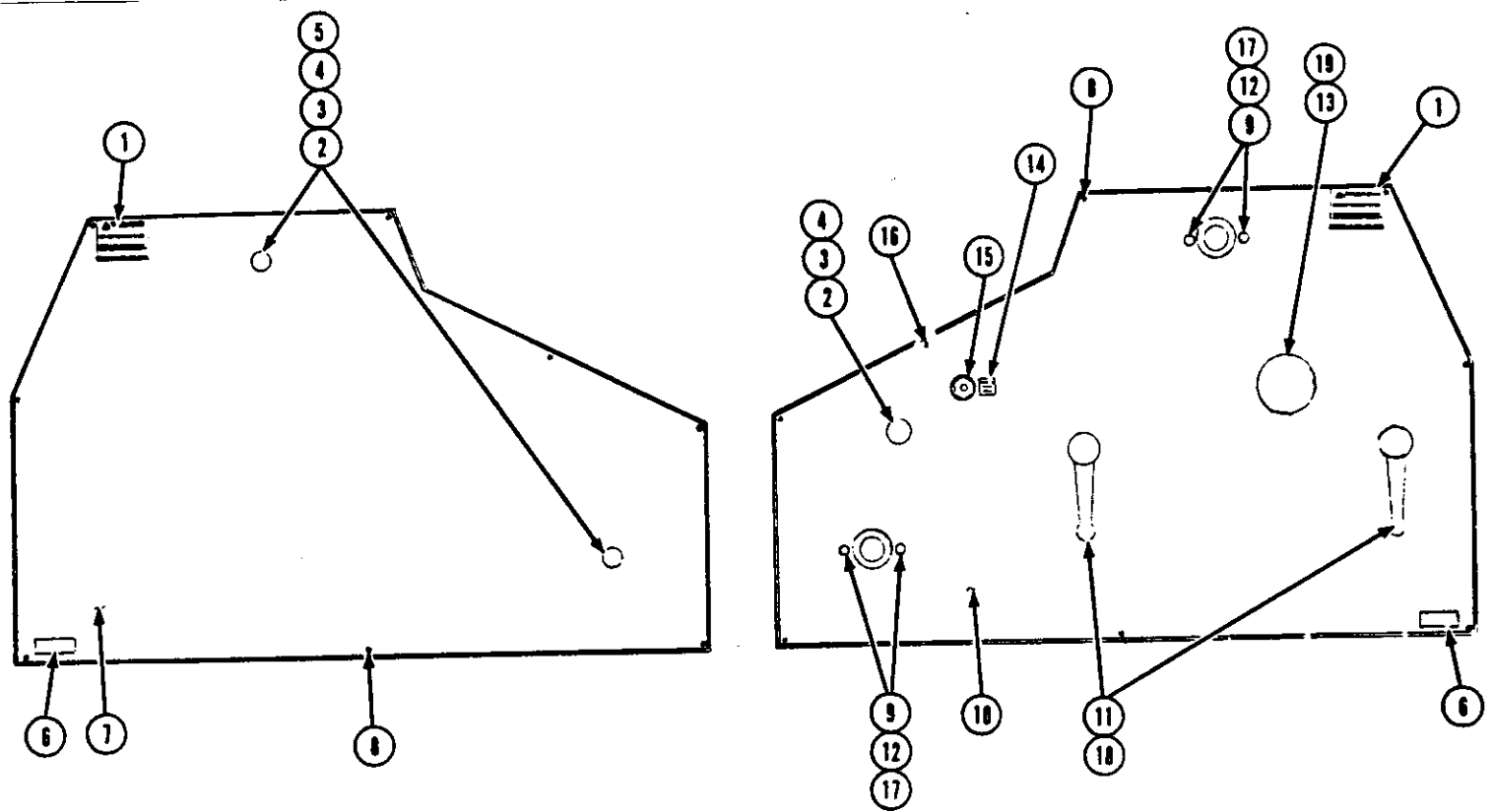

Figure 8-3 Left and Right Side Panel View

<u>Item</u>	<u>Part No.</u>	<u>Description</u>	<u>Quantity</u>
1	1156188	"Do Not Service" Label	2
2	1140564	Adjust Shaft	3
3	1140091	Peg Bearing	5
4	1140566	Shaft Knob, Left	3
5	1140565	Shaft Lock Nut, Left	2
6	6009000	"Caution" Label	2
7	1152235	Left Side Cover	1
8	1911103	Screw, 10-32 x 1/2	15
9	1152350	Knurled Knob	4
10	1152236	Right Side Cover	1
11	1140562	Roller Pressure Handle	2
12	1931714	Collar	4
13	1140053	Knob, Slitter	1
14	1156182	Jog Switch Label	1
15	1156178	Jog Switch	1
16	1911102	Screw, 10-32 x 1/4	1
17	1152302	Shaft	4
18	1900063	Set Screw, 1/4-20 x 1/2	14
19	1900041	Set Screw, 10-32 x 1/2	1

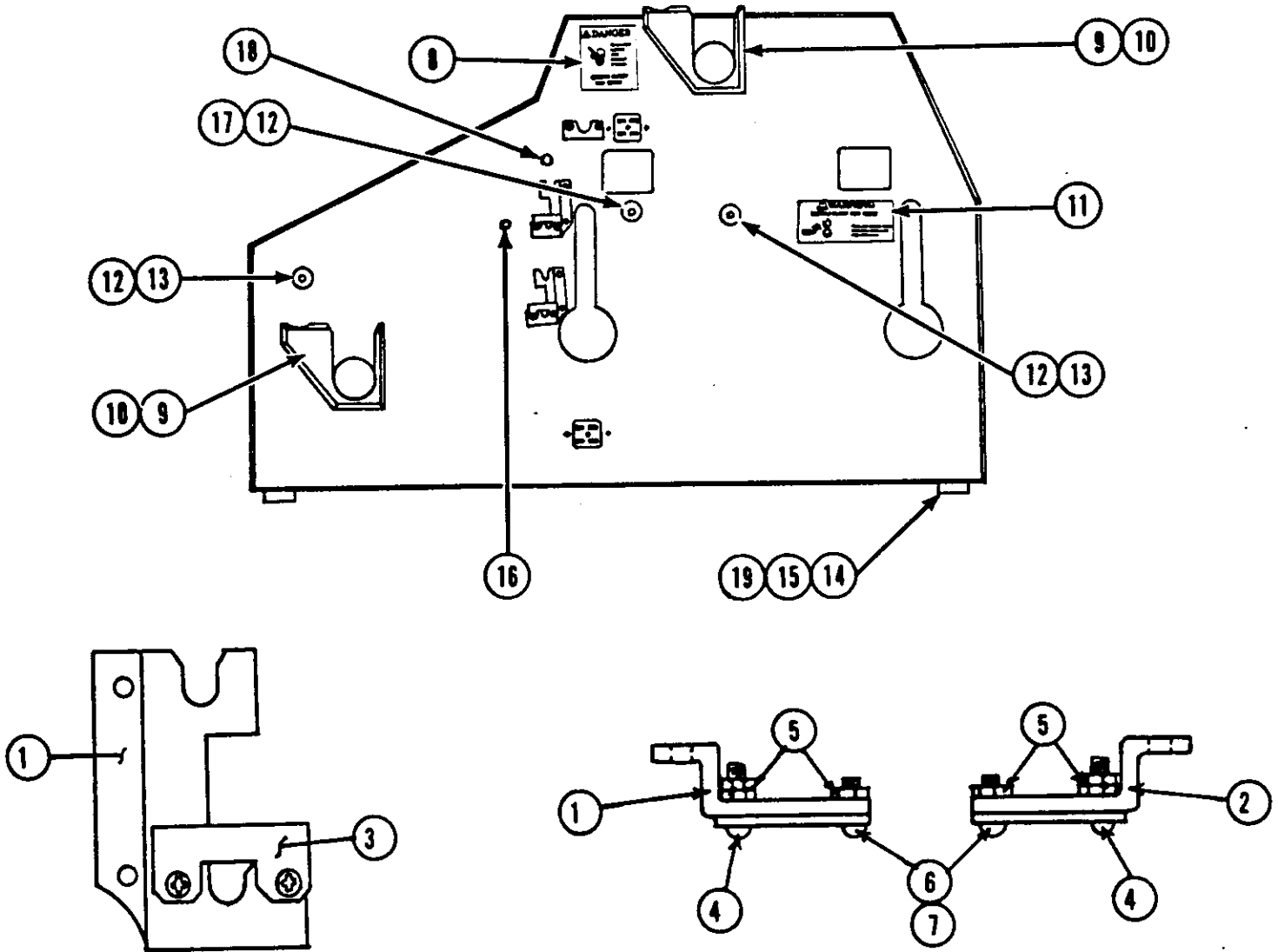
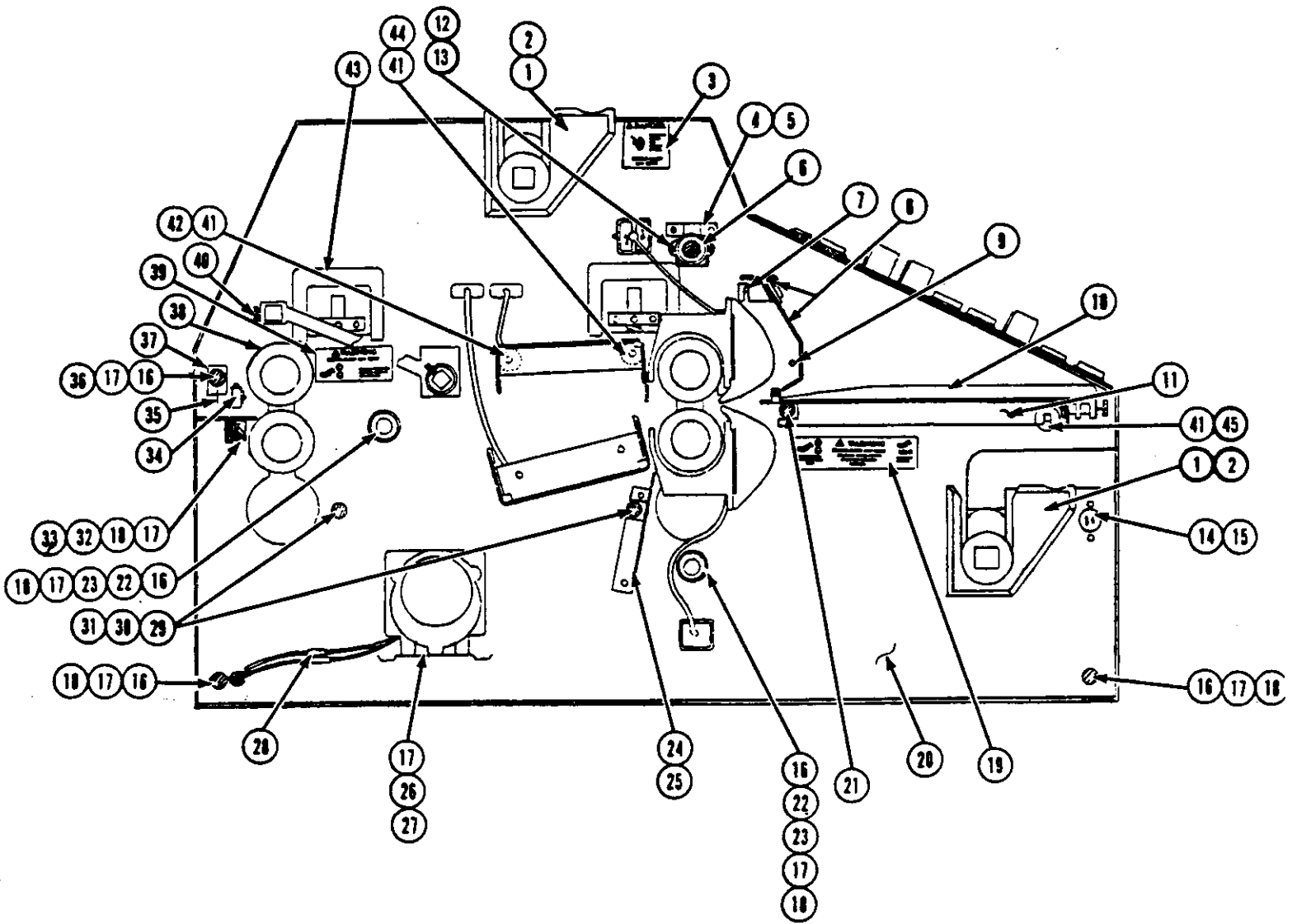

Figure 8-4 Inner Left Side View

<u>Item</u>	<u>Part No.</u>	<u>Description</u>	<u>Quantity</u>
1	1152474	Right Heater Bracket	2
2	1152475	Left Heater Bracket	2
3	1152476	Heater Bracket Latch	4
4	1902806	Screw; 8-32 x 5/8	4
5	1926701	Nut; 8-32	12
6	1900508	Screw; 8-32 x 1/4	4
7	1925806	Lock Washer; #8	4
8	1156184	"Exposed Heater Wire" Label	2
9	1140550	Supply Mandrel Support	4
10	1902807	Screw; 1/4-20 x 3/4 (Left Side Only)	4
11	1156183	Pull Roll Label	2
12	1140581	Support Pivot	6
13	1902801	Screw; 1/4-20 x 5/8	4
14	1140746	Foot	4
15	1902823	Screw; 8-32 x 1	4
16	1929203	Roll Pin; 1/8 x 3/4	2
17	1902625	screw; 1/4-20 x 5/8	2
18	1929227	Roll Pin; 1/4 x 1	2
19	1926803	Keps Nut; 10-32	4



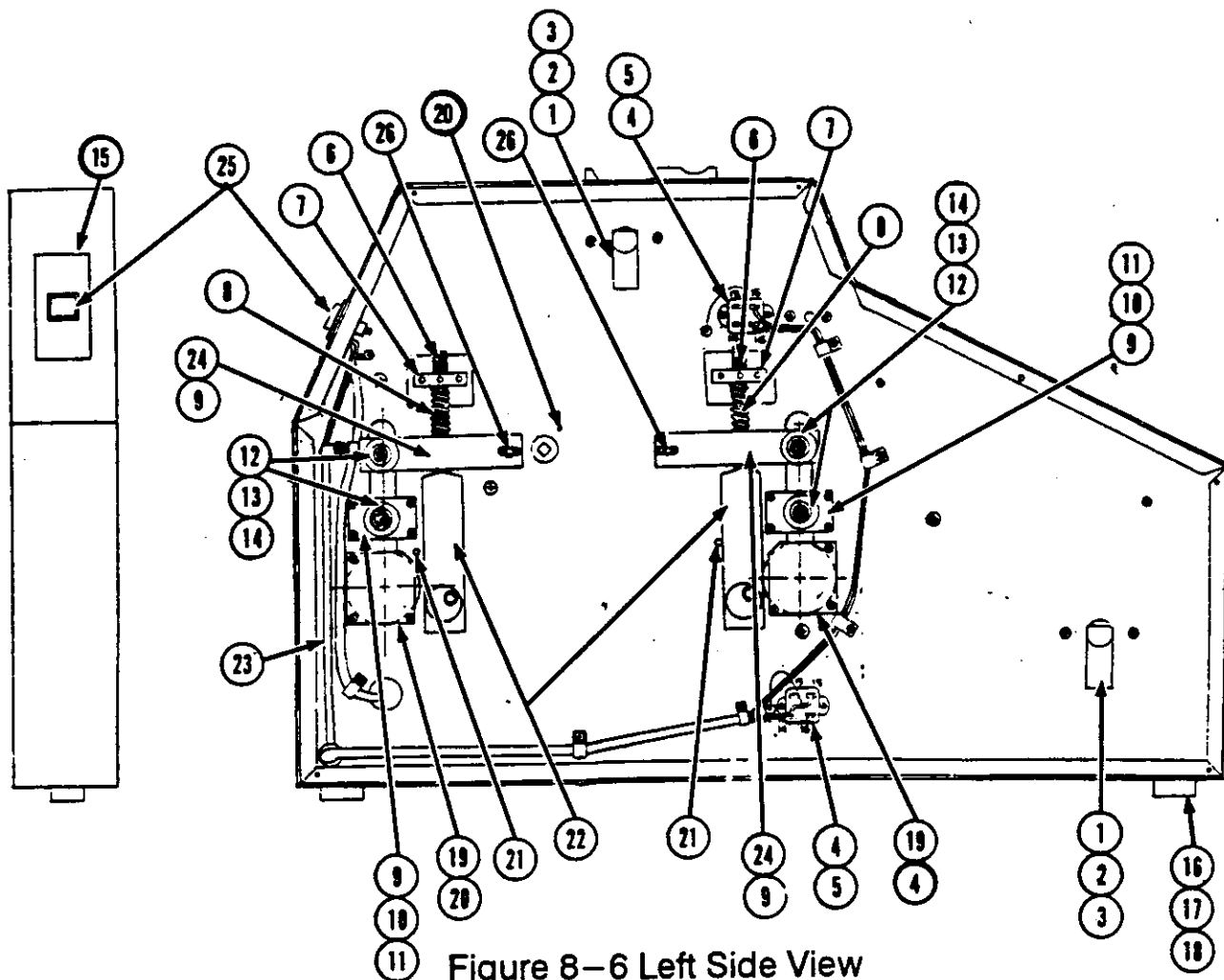

Figure 8-6 Left Side View

<u>Item</u>	<u>Part No.</u>	<u>Description</u>	<u>Quantity</u>
1	1152340	Adjusting Shaft Spacer	2
2	1152303	Adjusting Block	2
3	1902632	Screw; 10-32 x 3/4	4
4	1911109	Screw; 6-32 x 1/4	50
5	1152266	5 Contact Ground Socket	4
6	1140598	Spring Shaft	4
7	1140597	Tension Spring Nut	4
8	1140510	Roll Pressure Spring	4
9	1140587	Roller Shaft Bearing	8
10	1140538	Roller Bushing Block	4
11	1902627	Screw, 10-32 x 1	16
12	1930521	Retaining Ring	12
13	1925017	Washer	8
14	1925160	Washer	20
15	1152231	Panic Label	2
16	1140746	Foot	4
17	1911107	Screw; 10-32 x 5/8	4
18	1926803	Nut	4
19	6210013	Roller Entry Cover	4
20	1929203	Roll Pin; 1/8 x 3/4	2
21	1954110	Dowel Pin; 1/4 x 1	4
22	1140572	Pressure Roll Cam Bar	4
23	1152457	Shielded Cable Assembly	1
24	1140571	Pressure Roll Bearing Bar	4
25	1154205	Emergency Stop Switch	2
26	1900840	Shoulder Screw; 10-24	4

Figure 8-8 Right Side View

<u>Item</u>	<u>Part No.</u>	<u>Description</u>	<u>Quantity</u>
1	1152266	5 Contact Socket	4
2	1152348	2 Contact Socket	3
3	1156196	Capacitor	1
4	1152292	Contact	1
5	1152264	3 Contact Socket	2
6	1156176	Jog Control Board	1
7	1140630	Drive Chain, Upper	1
8	1140628	Drive Sprocket, Rear	4
9	1900081	Set Screw; 5/16-18 x 1/2	4
10	1852805	Square Key; 3/16 x 3/4	5
11	1931006	Wire Clamp	13
12	6210013	Roller Entry Cover	4
13	1140185	Drive Chain, Lower	1
14	1900810	Shoulder Screw	3
15	1140601	Double Idler Sprocket	1
16	1925144	Flat Washer; 3/8	3
17	1152484	Fuse Replacement Label	1
18	1140607	Fuse Block	1
19	1140811	Power Cord	1
20	1140812	Power Cord Plug	1
21	1146834	Sprocket, 15 Tooth	1
22	1152230	Velocity Disc	1
23	1902803	Screw; 6-32 x 1/4	20
24	1926005	Lock Washer	4
25	1140655	Fuse, 45 Amp	2
26	1152229	Motor Sensing Bracket	1
27	1152228	Motor Sensor Mounting Bracket	1
28	1152279	Interrupter Bracket	1
29	1140576	Idler Adjusting Plate	2
30	1902807	Screw; 1/4-20 x 3/4	2
31	1140557	Idler Sprocket	3
32	1900839	Shoulder Screw; 5/16-18 x 1/4	1
33	1140578	Idler Sprocket	2
34	1140604	Drive Idler Mounting Plate	1
35	1902641	Screw; 1/4-20 x 1	4
36	1152412	Power Block	1
37	1156130	Switch Bracket	1
38	1152272	Control Board Assembly	1
39	1152438	Interrupter Harness	1
40	1152315	Triac	2
41	1152430	6' Ribbon Cable	1
42	1152431	13' Ribbon Cable	1
43	1963910	Fuse Label	1
44	1140021	Fuse Holder	2
45	1102211	Fuse, 8 Amp	2
46	1152274	Power Board	1
47	1152429	2" Ribbon Cable	1
48	1152300	Transformer	1
49	1951701	Terminal Block	1
50	1156195	Relay	1
51	1140575	Idler Mounting Plate	1
52	See Figure 8-8	Brake Assembly	2
53	1152624	Snap Switch	2
54	1156130	Switch Bracket	2
55	6210009	Supply Mandrel Exit Cover	1
56	1156178	Jog Switch	1

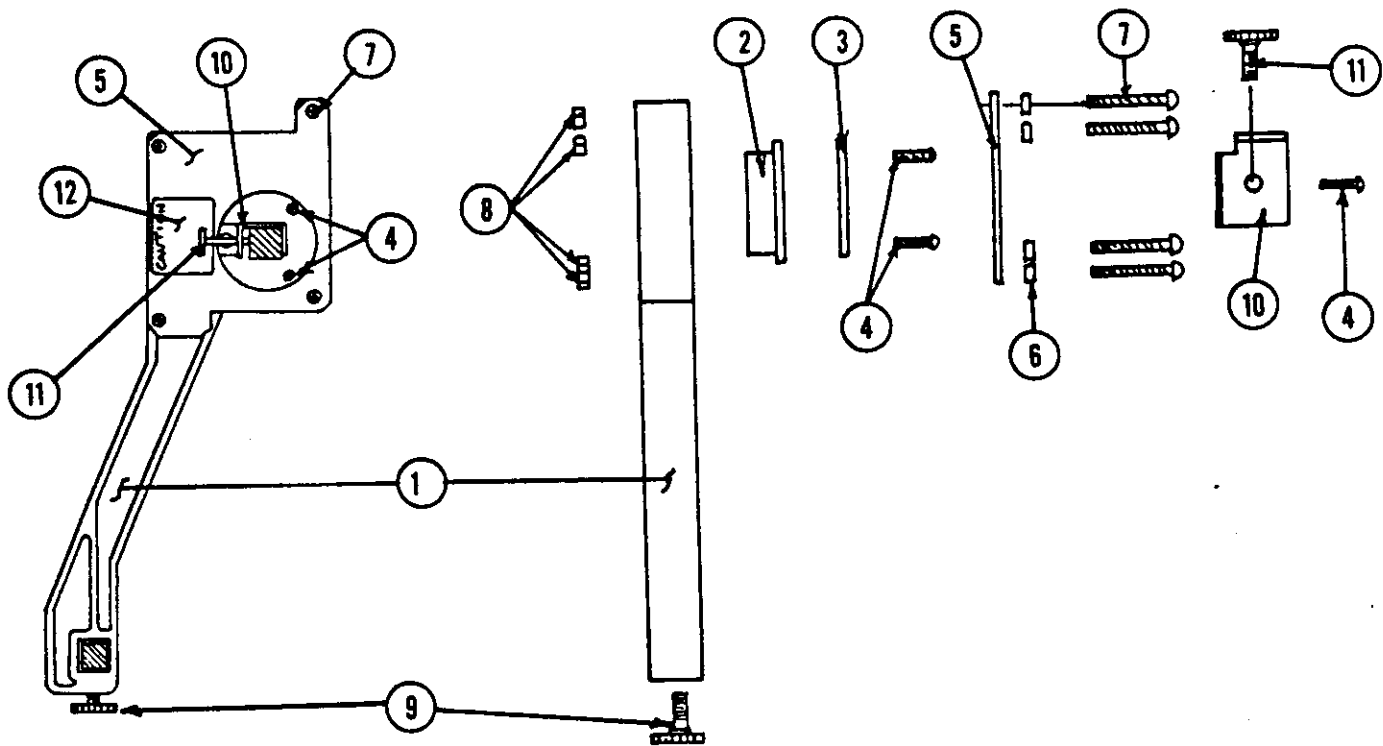
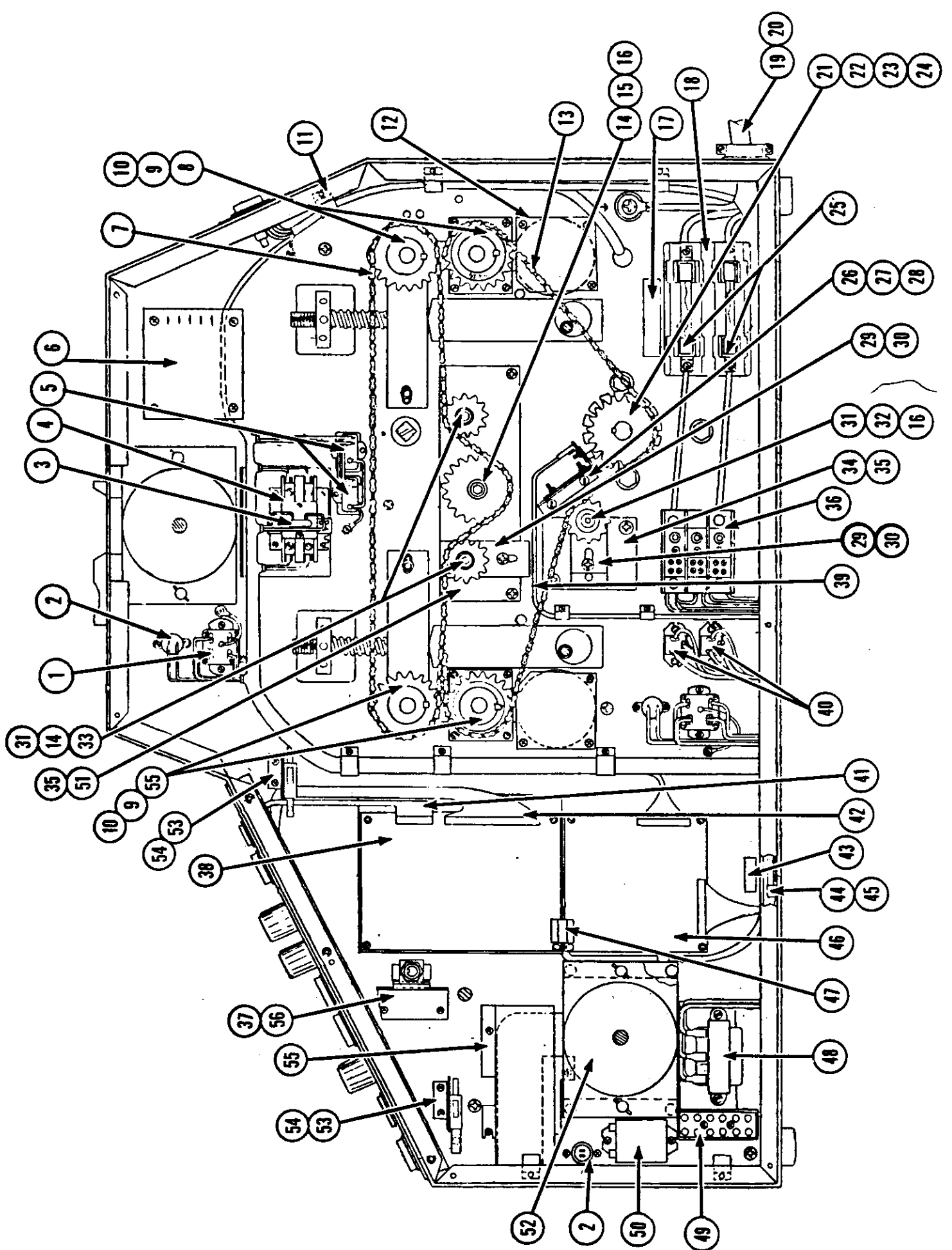

Figure 8-7 Slitter Assembly

<u>Item</u>	<u>Part No.</u>	<u>Description</u>	<u>Quantity</u>
1	1152299	Slitter Arm	3
2	1152298	Slitter Holder	3
3	1152286	Clamp Plate, Slitter	3
4	1911109	Screw; 6-32 x 1/4	9
5	1152297	Retainer, Slitter	3
6	1925202	Flat Washer; 11/64	12
7	1902812	Screw; 6-32 x 7/8	12
8	1926801	Nut; 6-32	12
9	1140078	Knurled Knob	3
10	1152653	Slitter Bracket	3
11	1914203	Knurled Knob; 10-32 x 1/2	3
12	1140051	Slitter Blade Caution Label	6





F12

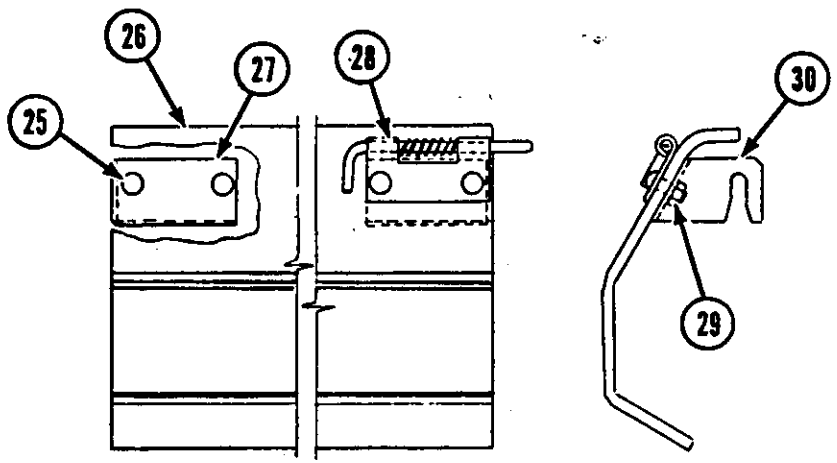
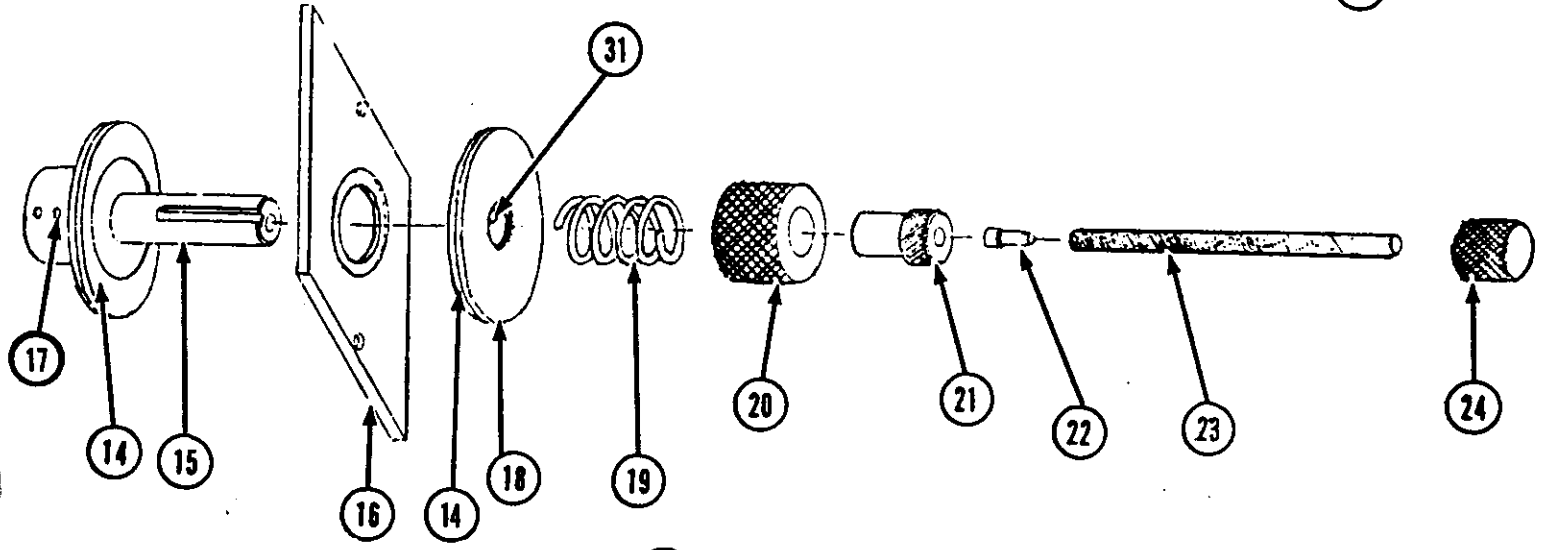
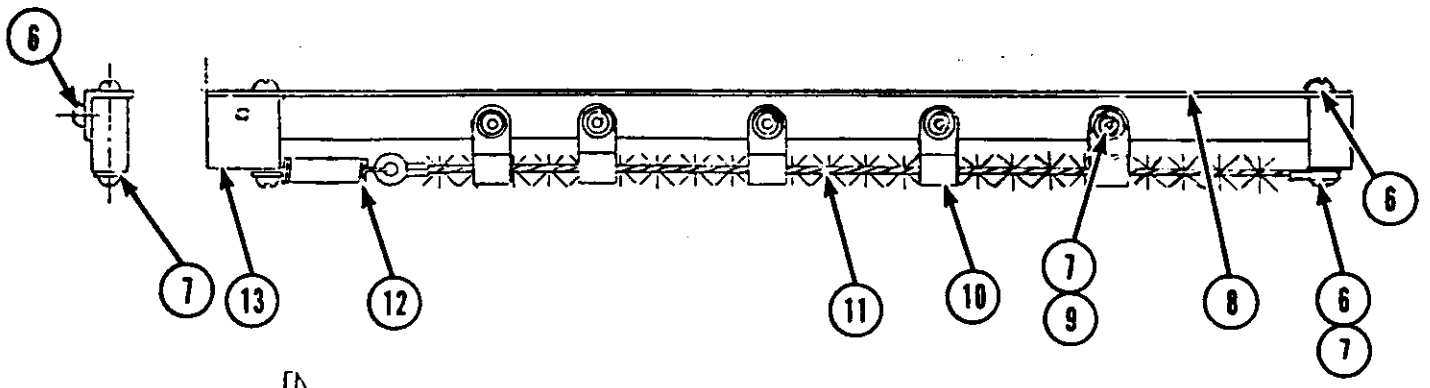
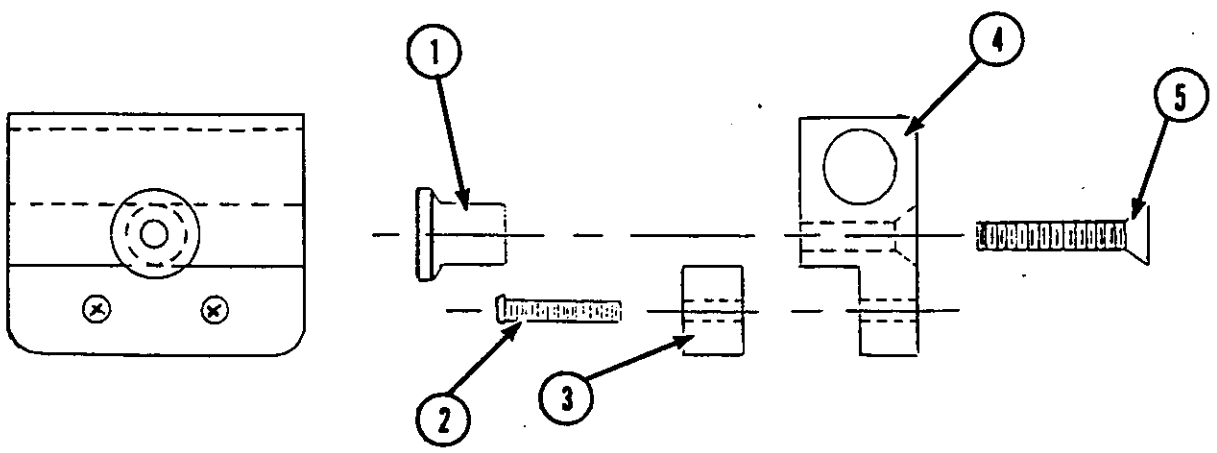

Figure 8-9 Component Parts Breakdown

<u>Item</u>	<u>Part No.</u>	<u>Description</u>	<u>Quantity</u>
1	1140617	Knob	1
2	1902852	Screw; 10-24 x 1	2
3	1140541	Blace Holder Clamp	1
4	1140540	Slitter Blade Holder	1
5	1902645	Screw; 1/4-20 x 1 1/4	1
6	1902818	Screw; 6-32 x 3/8	6
7	1925008	Flat Washer; #8	7
8	1140805	Anti-Static Bar	1
9	1929772	Rivet	5
10	1931004	Cable Clamp	5
11	1140808	Ground Tinsel Assembly	1
12	1140809	Extension Spring	1
13	1140806	Mounting Block	2
14	<u>1152301</u>	Brake Pad	4
15	1152328	Brake Hub	2
16	1152267	Floating Plate	2
17	1954125	Dowel Pin; 3/16 x 1	4
18	1152330	Brake Plate	2
19	1140512	Brake Spring	2
20	1140505	Brake Adjustment Knob	2
21	1140567	Shaft Lock-Nut, Right	2
22	1140091	Peg Bearing	5
23	1140570	Mandrel Adjustment Shaft	2
24	1140568	Shaft Knob, Right	2
25	1903028	Screw; 8-32 x 1/2	4
26	1156155	Safety Shield	1
27	1156158	Bracket, Left	1
28	1156166	Spring Latch	1
29	1926802	Keps Nut	60
30	1156159	Bracket, Right	1
31	1929205	Roll Pin; 3/16 x 1 1/8	2

*Drop ship  
RCD -  
Brake pad*

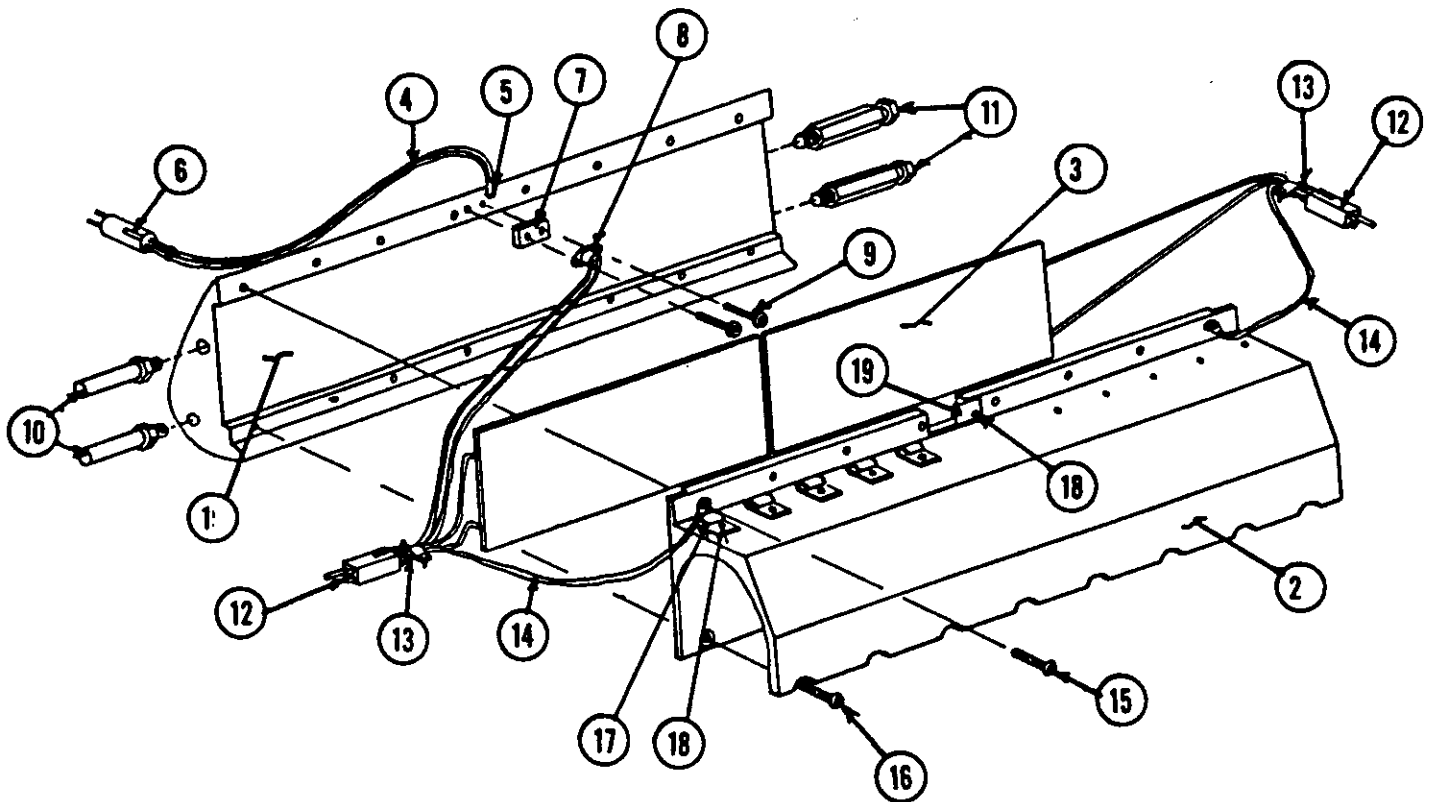

Figure 8-11 Heat Shoe Assembly

<u>Item</u>	<u>Part No.</u>	<u>Description</u>	<u>Quantity</u>
1	1152224	Heat Shoe	2
2	1152220	Roller Cover	2
3	1152640	Heater Element	4
4	1118556	RTD Sensor	2
5	1954325	Insulating Sleeve	2
6	1152347	2 Contact Plug	2
7	1154840	Thermostat Mounting Block	2
8	1154841	Thermostat	2
9	1902842	Screw; 4-40 x 3/8	4
10	1152654	Post	4
11	1152655	Grooved Post	4
12	1152265	Male Connector	4
13	1954334	Shrink Tube	4
14	1152284	Lead & Terminal Assy (Green)	4
15	1902853	Screw; 10-24 x 5/8	20
16	1902643	Screw; 10-24 x 3/8	20
17	1152308	Spring Clip	14
18	1907812	Screw, 4-40 x 1/4	16
19	1152311	Spring	2

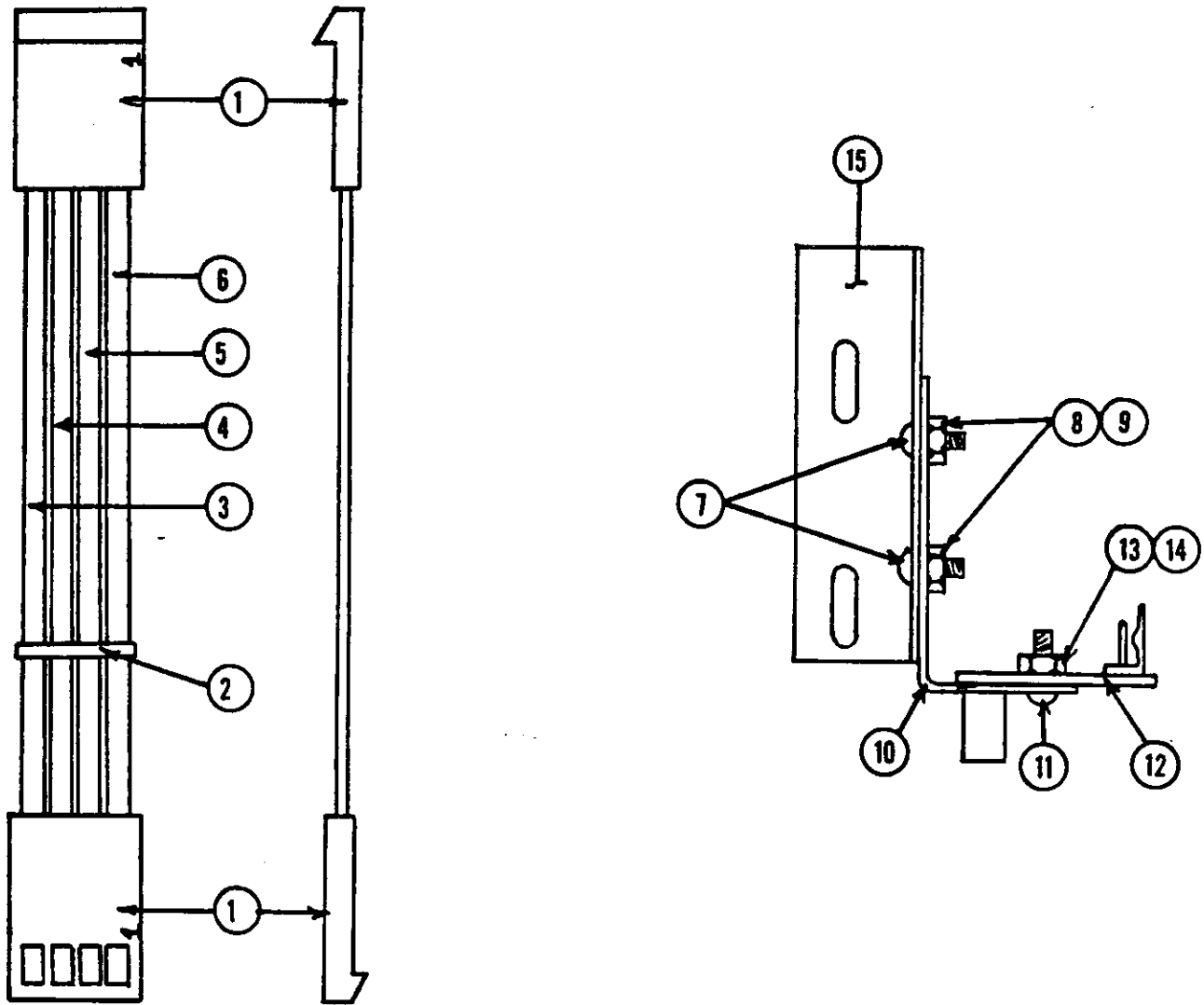

Figure 8-10 Interrupter Board and Harness Assembly

<u>Item</u>	<u>Part No.</u>	<u>Description</u>	<u>Quantity</u>
***	1152438	Interrupter Harness	1
1	1951302	Connector 4 Pin Socket	2
2	1932121	Wire Tie	5
3	1152349	Lead & Terminal (Green)	1
4	1152440	Lead & Terminal (Red)	1
5	1152441	Lead & Terminal (Orange)	1
6	1152442	Lead & Terminal (Blue)	1
7	1911109	Screw; 6-32 x 1/4	2
8	1925007	Flat Washer; #6	2
9	1926614	Nut; 6-32	2
10	1152228	Motor Sensor Mounting Bracket	1
11	1902842	Screw; 4-40 x 3/8	1
12	1152279	Interrupter Board	1
13	1925801	Lockwasher; #8	2
14	1926704	Nut; 4-40	2
15	1152229	Motor Sensor Bracket	1
***	Contains Items 1-6		

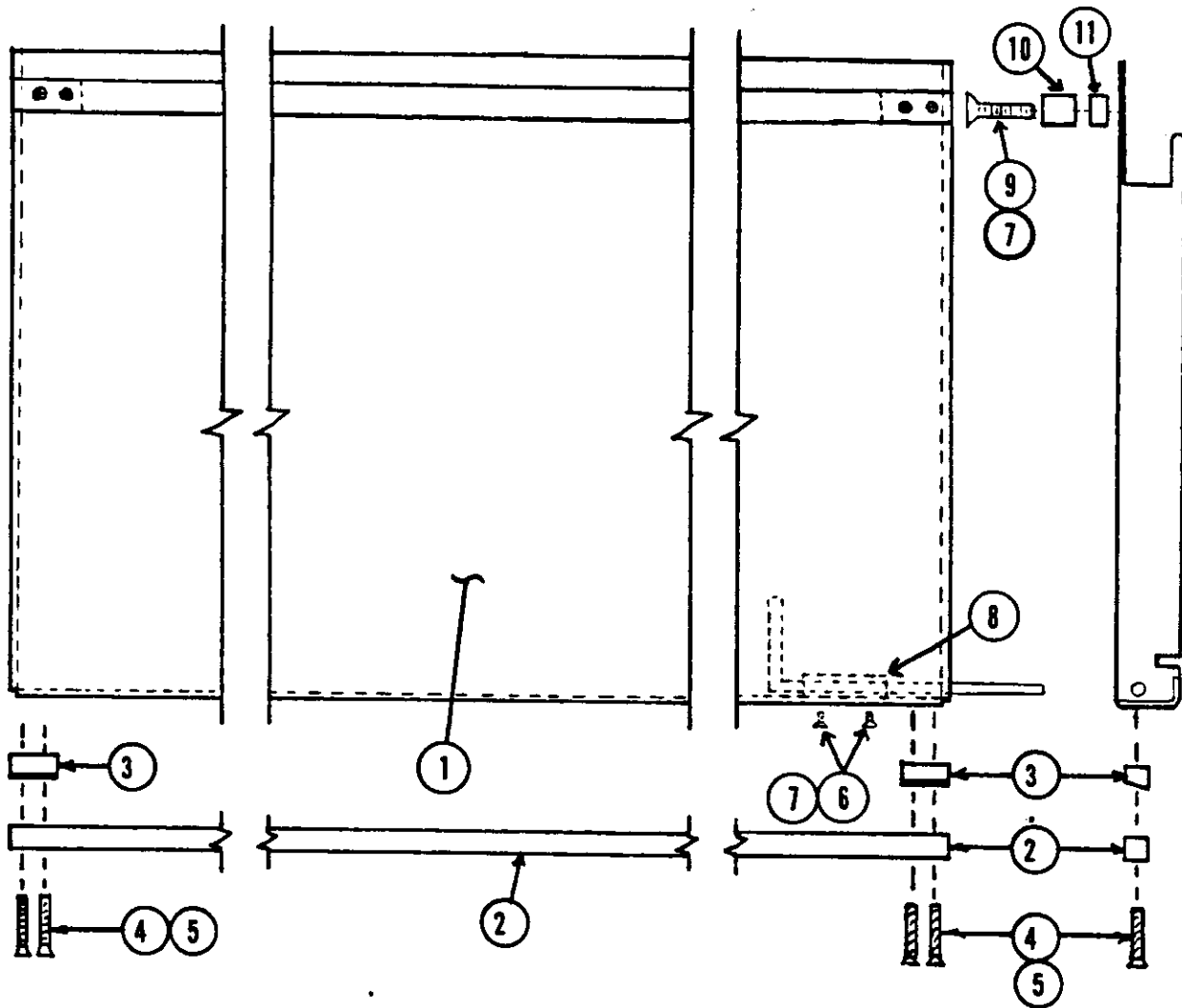

Figure 8-12 Feed Table Assembly

<u>Item</u>	<u>Part No.</u>	<u>Description</u>	<u>Quantity</u>
1	1152490	Feed Table	1
2	1152651	Guide Tray Support Bar	1
3	1152652	Guide Tray Spacer	2
4	1902628	Screw; 8-32 x 1 1/2	4
5	1926701	Nut; 8-32	12
6	1902647	screw, 8-32 x 1/2	7
7	1926802	Nut; 8-32	60
8	1156165	Spring Latch	1
9	1902612	Screw; 8-32 x 1	4
10	1156161	Safety Bar	1
11	1156164	Spacer, Safety Bar	2

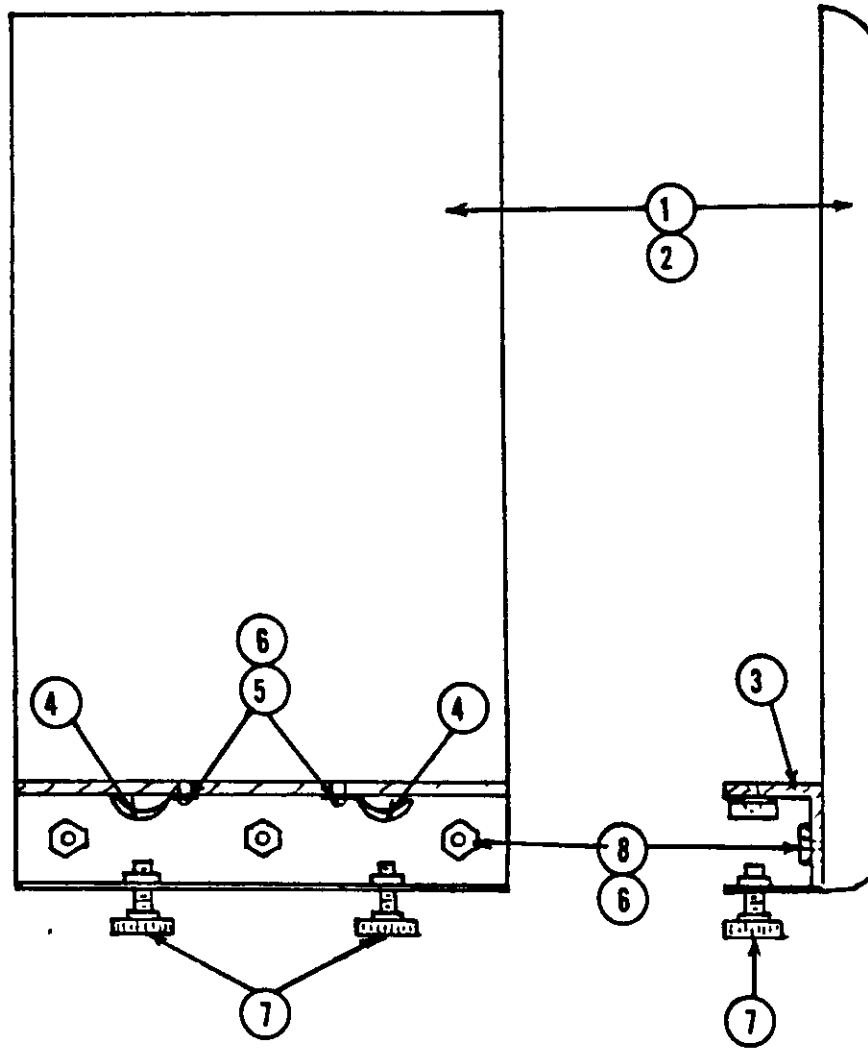

Figure 8-13 Guide Tray Assembly

<u>Item</u>	<u>Part No.</u>	<u>Description</u>	<u>Quantity</u>
1	1152667	Left Guide Tray	1
2	1152664	Right Guide Tray	1
3	1152648	Guide Channel	2
4	1152649	Guide Block Spring	4
5	1902803	Screw; 6-32 x 1/4	10
6	1925904	Lockwasher; #6	4
7	1140078	Knurled Knob	10
8	1926707	Nut; #6	10

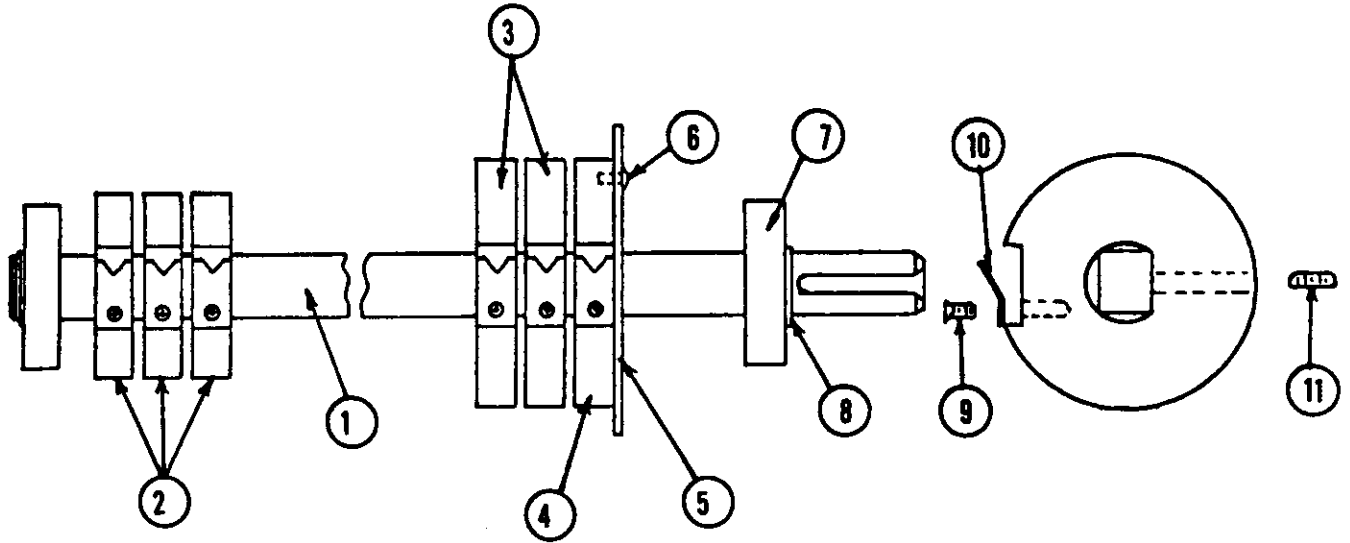

Figure 8-14 Supply Mandrel Assembly

<u>Item</u>	<u>Part No.</u>	<u>Description</u>	<u>Quantity</u>
1	1152333	Supply Mandrel	2
2	1152661	Core Adaptor, 2 1/4"	6
3	1152658	Core Adaptor, 3"	4
4	1152659	Core Adaptor, End	2
5	1152660	Core Adaptor Plate	2
6	1911116	Screw; 6-32 x 3/8	6
7	1140515	Bearing	4
8	1930521	Retaining Ring	4
9	1902803	Screw; 6-32 x 1/4	12
10	1152656	Core Adaptor Clip	12
11	1900063	Set Screw; 1/4-20 x 1/2	12