

F-60+ Operation and Maintenance Manual

© 1999 GBC Pro-Tech
Do not duplicate without written permission

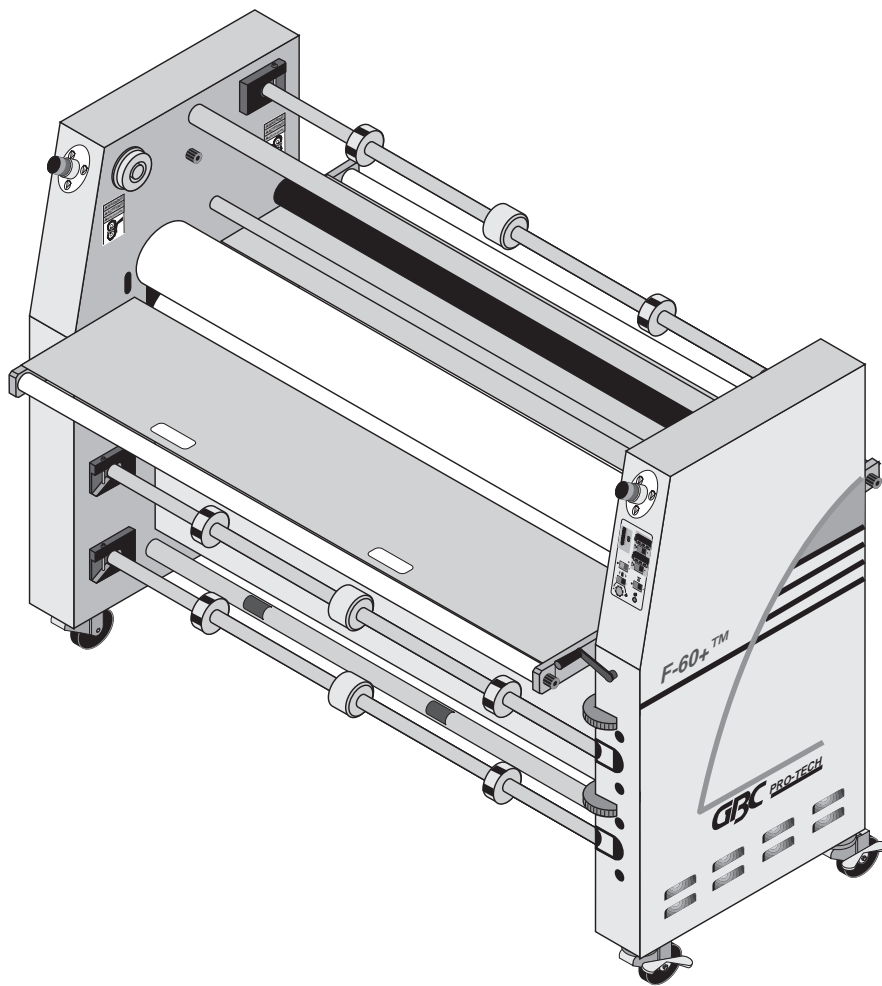

Part Number 930-023 Rev. A

GBC Pro-Tech
4151 Anderson Road
De Forest, Wisconsin 53532
Tel: 608-246-8844
Fax: 608-246-8645

The information in this publication is provided for reference and is believed to be accurate and complete. GBC Pro-Tech is not liable for errors in this publication or for incidental or consequential damage in connection with the furnishing or use of the information in this publication, including, but not limited to, any implied warranty of fitness or merchantability for any particular use.

GBC Pro-Tech reserves the right to make changes to this publication and to the products described in it without notice. All specifications and information concerning products are subject to change without notice.

Reference in this publication to information or products protected by copyright or patent does not convey any license under the rights of GBC Pro-Tech or others. GBC Pro-Tech assumes no liability arising from infringements of patents or any other rights of third parties.

This manual is copyrighted ©1999 by GBC Pro-Tech. All rights reserved. The information contained in this manual is proprietary and may not be reproduced, stored, transmitted, or transferred, in whole or in part, in any form without the prior and express written permission of GBC Pro-Tech.

Table of Contents

Section 1 : Safety	1-1
Caution/Warning Label Locations	1-3
Section 2 : Installation	2-1
Preinstallation Checklist	2-1
Unpacking	2-4
Setup	2-6
Leveling	2-7
Startup	2-7
Section 3 : Operation	3-1
Safety	3-1
Operator Controls	3-2
Front Control Panel	3-2
Footswitch Operation	3-2
Rear Control	3-3
Setup	3-3
Laminator Main Roll Pressure	3-3
Laminator Pull Roll Pressure	3-3
Web Up Options	3-3
Loading the Film	3-4
Recommended Materials	3-4
Films	3-4
Positioning the Film	3-4
Heating	3-5
Pull Roll Clutch Adjustment	3-5
Paper Tips	3-5
Process Control Charts	3-6
Mounting Only	3-6
Setup	3-6
Procedure	3-7
Mounting/Laminating	3-7
Setup	3-7
Procedure	3-7

Encapsulation	3-7
Setup	3-7
Procedure	3-7
Two-Pass Mount and Laminate (Hot and Cold)	3-7
Setup	3-7
Procedure, Pass 1	3-7
Procedure, Pass 2	3-8
Section 4 : Maintenance and Troubleshooting	4-1
Cleaning	4-1
Adjusting the Nip	4-3
Chain Tensioning	4-4
Lubrication	4-5
Contacting Technical Support	4-5
Output Troubleshooting Guide	4-6
Section 5 : Warranty	5-1
Limited Warranty	5-1
Exclusions to the Warranty	5-1
Section 6 : Specifications, Parts and Schematic	6-1
Section 7: Index	7-1

Section 1 : Safety

DO NOT ATTEMPT TO OPERATE YOUR F-60+ LAMINATOR UNTIL YOU HAVE READ THIS SECTION CAREFULLY!

Your safety, as well as the safety of others, is important to GBC Pro-Tech. This section contains important safety information.

The following symbols are used throughout this manual to indicate warnings and cautions.



Indicates an imminently hazardous situation which, if not avoided, will result in death or serious injury.



Indicates a potentially hazardous situation which, if not avoided, could result in death or serious injury.



Indicates a potentially hazardous situation which, if not avoided, could result in minor or moderate injury, or alerts against unsafe practices, or alerts against actions which could damage the product.

The F-60+ Laminator has been designed with safety as a primary consideration. However, you must become thoroughly familiar with the controls, proper operation, proper service procedures, and safety features of the laminator before using or servicing the unit.

GBC Pro-Tech F-60+ Laminator is a powerful machine that is designed to mount, laminate and encapsulate. The forces required to accomplish these tasks can vary from negligible to very large.

In addition, the laminating roll of the F-60+ can reach temperatures of 270 °F (132 °C). At these temperatures there is a danger of a severe burn if the roll is touched during set-up, operation or servicing.

Safety is an important feature of the F-60+ Laminator. It has emergency stop buttons and a mechanical guard system on the infeed. In addition, the pull rolls are contained in an enclosure to prevent injury.

The laminator is equipped with four emergency stop buttons located on the top front and back of either side of the laminator. Any of these, if engaged, stops the laminator. To continue operation all emergency stop buttons must be in the up position and you must press the reset button above the fuse panel on the back of the laminator (see Figure 1-2). The laminator is also equipped with a power lockout (see Figure 1-3) which stops power to the machine.

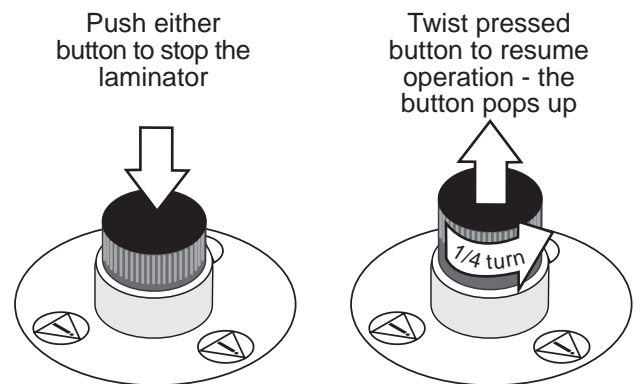

Figure 1-1: Using the Emergency Stop Buttons

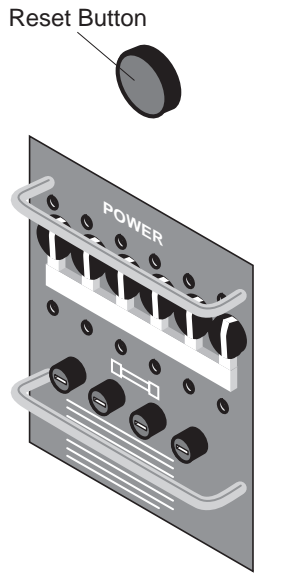

Figure 1-2: Resetting the Laminator

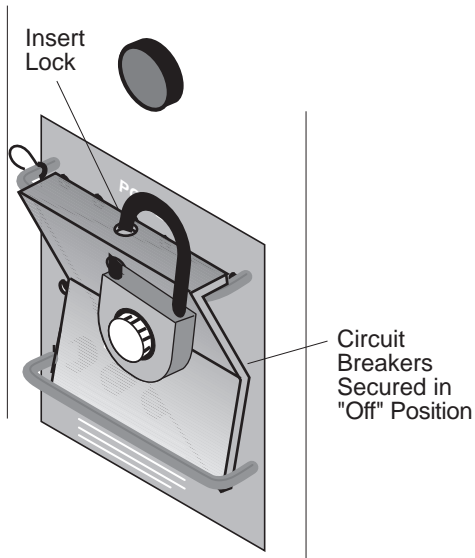

Figure 1-3: Power Lockout

Despite the safety features built into the F-60+ Laminator, extreme caution must be used when operating or servicing the unit. **READ THE FOLLOWING WARNINGS AND CAUTIONS BEFORE ATTEMPTING TO OPERATE OR SERVICE THE F-60+ LAMINATOR.**

! WARNING

Never place fingers or arms between the rolls when they are turning or when the rolls are in the closed position. You can be crushed or burned.

! WARNING

Do not wear ties, loose fitting clothing or dangling jewelry while operating or servicing the laminator. These items can get caught in the nip and choke you or you can be crushed or burned.

! WARNING

Do not operate the laminator near water. You can be severely shocked, electrocuted or cause a fire.

! DANGER

Remove and lock out power from the laminator before servicing. You can be severely shocked, electrocuted or cause a fire.

! WARNING

Do not use liquid or aerosol cleaners on the laminator. Do not spill liquid of any kind on the laminator. You can be severely shocked, electrocuted or cause a fire. Use only a damp cloth for cleaning.

! WARNING

Exercise care when cleaning the rolls with 80% isopropyl alcohol:

- Use only in a well ventilated area.
- Wear rubber gloves.
- Use only on cool rolls.

Cleaning heated rolls can ignite the fumes.



Use only 80% isopropyl alcohol or a rubber cement eraser to clean the laminating rolls. Harsh chemicals like toluene, acetone or MEK destroy the silicone covering of the rolls.



Raise the upper main roll when the laminator is not in operation. Prolonged contact can damage the rolls.



Excess pressure can damage the laminating rolls. Always select the minimum roll pressure necessary to complete the task.



If silicone adhesive contacts the upper or lower roll, remove it IMMEDIATELY using 80% isopropyl alcohol. It can harden within an hour and ruin the roll.



The operating environment must be free of dust, flammable liquids and vapors. You can be injured by inhaling chemical vapors. Vapor build up or stored flammable liquids can cause a fire. Excessive dust can damage the laminator.



Do not use a knife or other sharp instrument during installation or while servicing the laminator. You can cause irreparable damage to the rolls.



Do not attempt to move the laminator across anything other than a flat, level surface without trained and qualified riggers. You can be crushed or seriously injured.

The F-60+ Laminator is a large and heavy piece of equipment. It is necessary to employ LICENSED RIGGERS ONLY to move the machine. GBC Pro-Tech's warranty does not cover malfunction of the equipment due to mishandling.

GBC Pro-Tech bears no responsibility for personal injury or damage due to moving the laminator improperly.



Do not operate the laminator if the power cord is damaged or frayed. You can be severely shocked, electrocuted or cause a fire. Contact a qualified electrician to replace the cord.



Do not allow anything to rest on the power cord. Do not locate the cord where people can walk on it. You or others can be severely shocked, electrocuted or cause a fire.

Always use good safety practices when operating or servicing the laminator and know how to react quickly in an emergency.

Caution/Warning Label Locations

Posted at various locations on your F-60+ Laminator are important safety labels. PAY CAREFUL ATTENTION TO THESE LABELS AT ALL TIMES! Figure 1-4 shows the location of each of these labels.

(Inside cabinet)



(Inside cabinet)

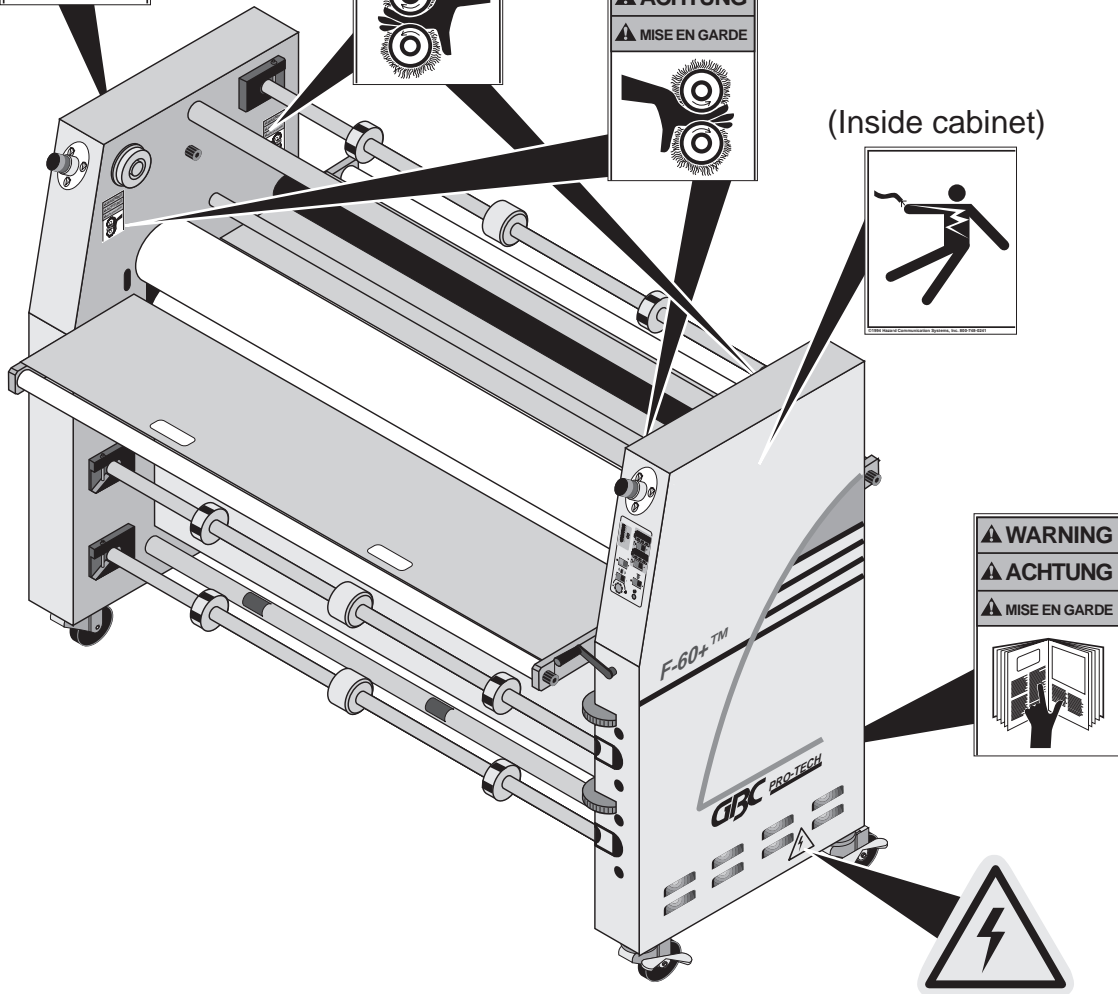

Figure 1-4: Locations of Safety Labels

F-60+ Operation and Maintenance Manual

The following are typical safety hazard decals used on GBC Pro-Tech machines, with a brief description (“Meaning” column) of each decal.

Decal	Meaning
	<p>WARNING!</p> <p>Moving parts can crush and cut.</p> <p>Do not operate with guard or door open.</p>
	<p>WARNING!</p> <p>Crush and burn hazard. Stay clear of moving rollers. Stop machine and raise roll before cleaning.</p>
	<p>WARNING!</p> <p>Carefully read Operator's Manual before handling this machine. Observe instructions and safety rules when operating.</p>
	<p>WARNING!</p> <p>HAZARDOUS VOLTAGE.</p> <p>To be serviced only by trained and authorized personnel.</p> <p>Lockout power before servicing.</p>
	<p>CAUTION!</p> <p>Surface is hot.</p> <p>A burn hazard exists.</p>
	<p>CAUTION!</p> <p>Rolls are heavy. Use proper lifting techniques to prevent injury.</p>

Decal	Meaning
	<p>WARNING!</p> <ol style="list-style-type: none"> 1. Read and understand the Operation Manual and all safety labels before operating this machine. 2. Only a trained person is to be permitted to operate this machine. Training should include instruction in operation under normal conditions and emergency situations. 3. This machine is to be serviced only by trained and authorized personnel. Follow lockout procedures before servicing. 4. Never reach into the machine for any reason unless the machine is at a COMPLETE STOP. 5. Never leave the machine stopped in such a manner that another worker can start the machine while you are working on or within the machine. 6. Never change or defeat the function of electrical interlocks or other machine "shutdown" switches. 7. Before starting this machine, check that: <ul style="list-style-type: none"> - All persons are clear of the machine. - No maintenance work is being performed on the machine. - All guards are in place. - All parent rolls are well chucked in the unwind stands. - The machine is free of paper scraps, wraps and jams. 8. There is a potential hazard of entanglement in this machine caused by items such as long hair, loose clothing, and jewelry. Make sure your clothing and hair fit closely to your body and that all jewelry, rings and watches are removed.
	<p>CAUTION!</p> <p>Air pressure must be less than 100 PSI (700 kPa) to avoid damaging the machine.</p>
	<p>Reset.</p>
	<p>WARNING!</p> <p>EMERGENCY STOP BUTTON</p> <p>Press this button to stop the machine cycle, remove electric power, and separate (open) rolls to eliminate a pinch point (on some machines).</p>
	<p>Electric power disconnect and lock out location.</p>

Blank page.

Section 2 : Installation

GBC Pro-Tech is committed to a program of ongoing product improvement. As a result, we are providing these instructions so that you can insure that your new F-60+ Laminator is properly and securely unpacked, moved and installed.

Before a F-60+ Laminator can be installed, there are a few requirements that must be met. Make certain that each of the requirements listed in the following preinstallation checklist are met before beginning installation.



CAUTION

Failure to follow the preinstallation checklist can result in damage to the laminator.

Preinstallation Checklist

- Are doorways and hallways wide enough for the laminator to be moved to the installation site?
- Is there ample room for the laminator?
A work area must be established that allows for operation in both the front and the rear of the machine and provides space for efficient material flow. Figure 2-1 shows a typical machine area layout.
- Is the environment appropriate for the laminator?
The laminator requires a clean, dust and vapor free environment to operate properly, such as an air conditioned office area with forced 10% make up air. However, the laminator must not be located where there is air blowing directly on it. Major fluctuation in temperature and humidity are to be avoided.



WARNING

The operating environment must be free of dust, flammable liquids and vapors. You can be injured by inhaling chemical vapors. Vapor build up or stored flammable liquids can cause a fire. Excessive dust can damage the laminator.



CAUTION

Do not locate the laminator where air is blowing directly on the machine. The air flow can cool the rolls unevenly and result in poor quality output.

- Is there an appropriate power outlet available or has a certified electrician been contacted to wire the laminator directly?
The laminator requires 60A single phase, 220/230/240 VAC service or, in Europe, 3 Phase, 240 VAC with 30 Amps per phase. See Figure 2-2 for alternative power hookup configurations.



WARNING

Do not attempt to defeat the grounding feature of the ground plug on the laminator. You can be severely shocked, electrocuted or cause a fire. The three prong plug fits only into a grounding-type power outlet. If you are unable to insert the plug into the existing outlet, contact a qualified electrician to replace the obsolete outlet.



WARNING

Do not use an extension cord on this laminator. You can be severely shocked, electrocuted or cause a fire. If you need a longer cable contact a qualified electrician.



WARNING

Do not operate the laminator if the power cord is damaged or frayed. You can be severely shocked, electrocuted or cause a fire. Contact a qualified electrician to replace the cord.



WARNING

Do not allow anything to rest on the power cord. Do not locate the cord where people can walk on it. You or others can be severely shocked, electrocuted or cause a fire.

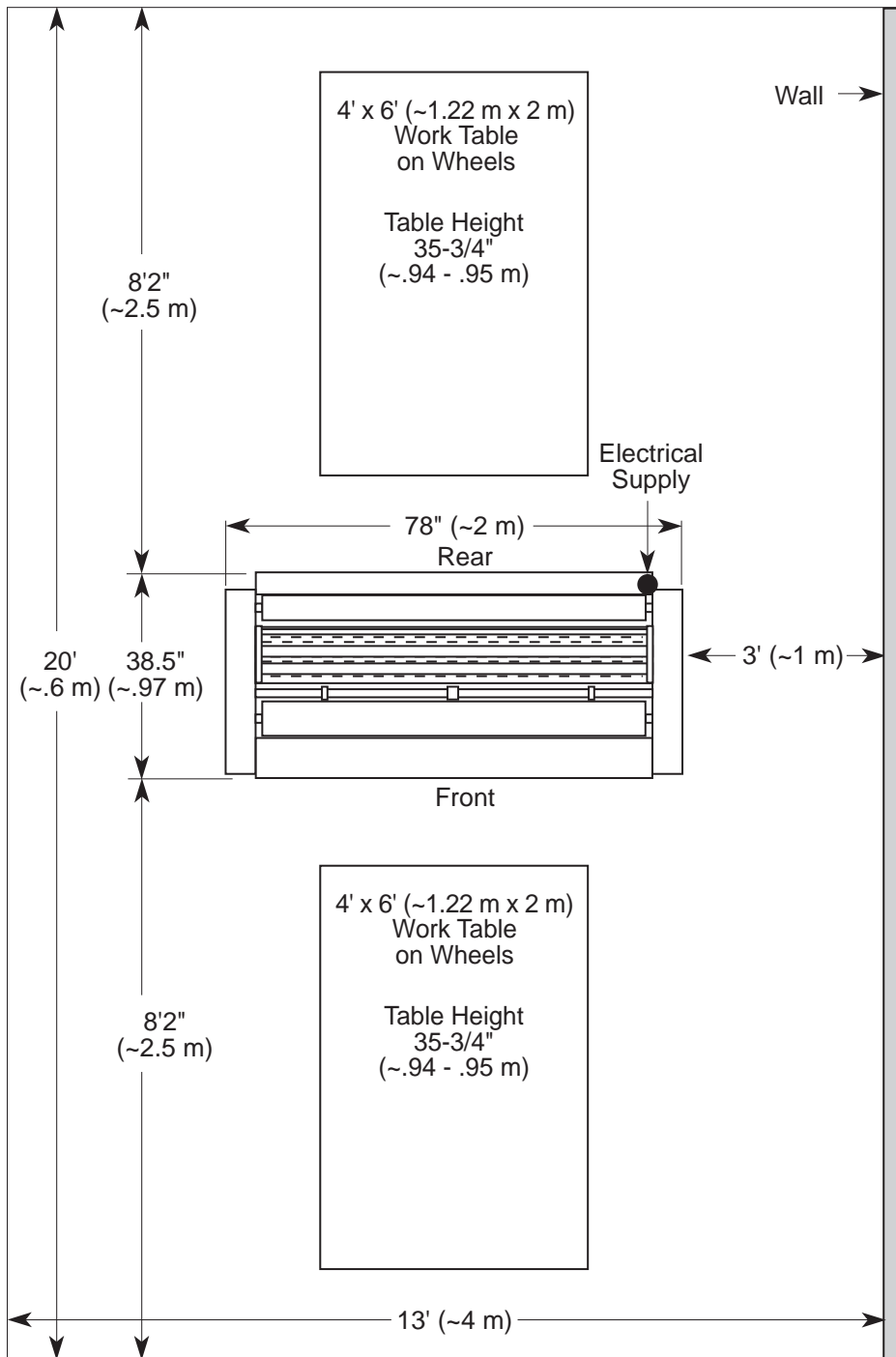

Figure 2-1: Laminator Space Requirements

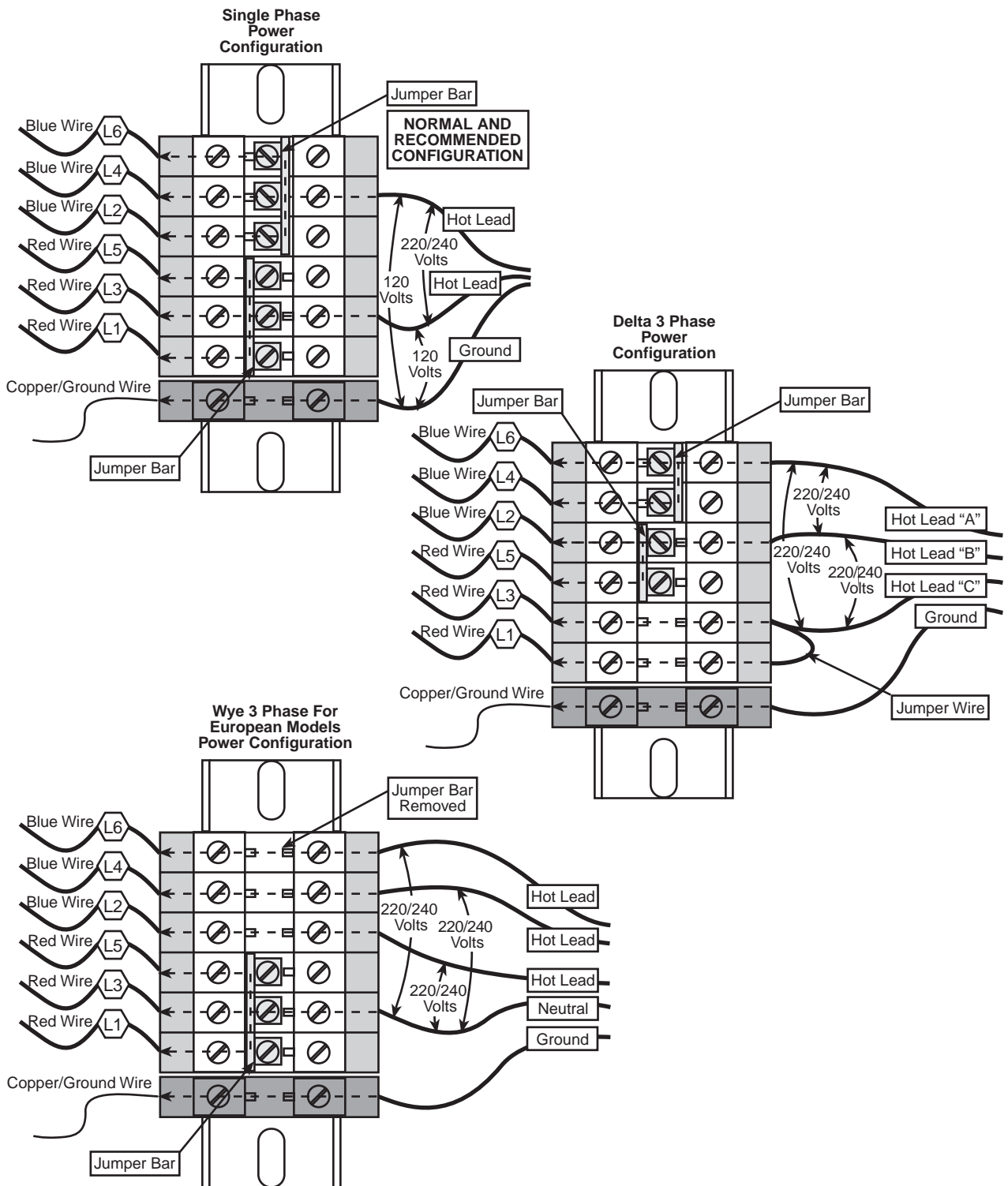

Figure 2-2: Alternative Power Configurations

Unpacking

NOTE

ALL SHIPMENTS ARE EX- WORKS. At our dock title passes to the buyer. Please review your insurance coverage prior to shipment, as you are responsible for all subsequent freight charges and risks. Before signing the Bill of Lading you should be sure to inspect the crate and/or pallet for signs of damage or missing items; if applicable, make a note of this on the Bill of Lading.

The F-60+ Laminator is shipped in a wood crate on a skid.



WARNING

The unpacking process requires at least two people. You can be severely injured or crushed.

Tools required:

- Phillips head screwdriver
- Adjustable wrench

To uncrate the laminator:

1. Remove the top of the crate and sides 2 and 3 as shown in Figure 2-3.

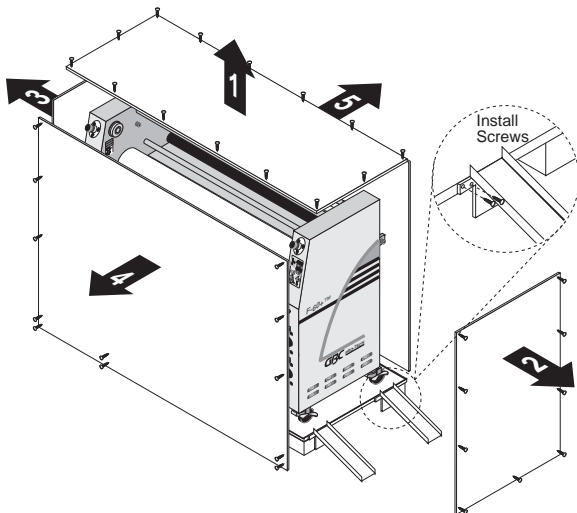

Figure 2-3: Removing the Crate

2. There are two hold down bridges that are connected to sides 4 and 5. Remove the hold down bridges and then remove sides 4 and 5.



CAUTION

Do not allow the top to fall into the crate. It can damage the laminator.

Do not put packing screws on the floor. They can cause problems when trying to roll the machine into position.

A second person must support the side labeled (5) in Figure 2-3. It can fall and damage the laminator.

3. The infeed pressure plate and ramps are attached to the skid. Remove them and set them aside for later installation.

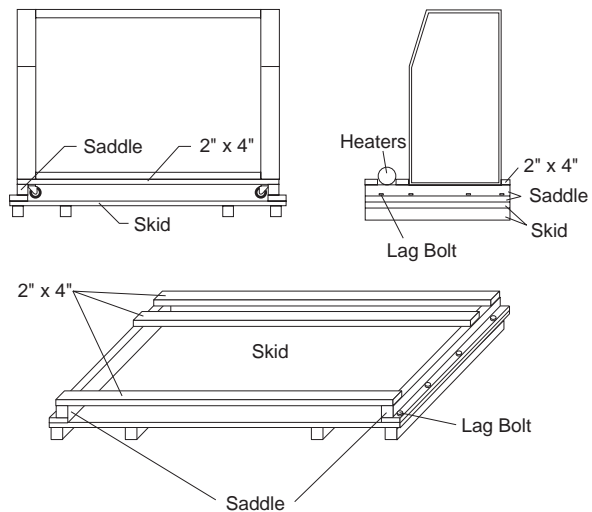

Figure 2-4: Skid Configuration



CAUTION

Do not use a knife or other sharp instrument during installation or while servicing the laminator. You can cause irreparable damage to the rolls.

4. Carefully remove the accessory pack from the skid.
The accessory pack should contain:
 - 1 Slitting knife
 - 1 Manual
 - 1 Set, spare fuses
 - 1 Roll of masking tape
 - 1 100% cotton terry cloth
 - 4 Leveling pads
5. Locate the foot switch so as to prevent the foot switch wire from being damaged during removal of the machine from the skid.
10. The ramps included with the laminator can be secured to the edge of the crate bottom using the screws left over from the crate disassembly (see Figure 2-3).
11. Have the machine moved off the skid and placed on the floor by licensed riggers.

Roll the machine off by securing included ramps to the edge of the crate bottom using the screws left over from the crate disassembly (See Figure 2-3).

Lift the machine off by applying fork lift truck blades to the two bottom tie bars between the cabinets. The fork lift blades must be located at the lift label locations on the tie bars (see Figure 2-5).

**WARNING**

Do not attempt to move the laminator across anything other than a flat, level surface without trained and qualified riggers. You can be crushed or seriously injured. Steps 6 through 11 should be completed by LICENSED RIGGERS ONLY.

The F-60+ Laminator is a large and heavy piece of equipment. It is necessary to employ LICENSED RIGGERS ONLY to move the machine.

GBC Pro-Tech bears no responsibility for personal injury or damage due to moving the laminator improperly.

6. The machine is supported above the skid by resting on a support saddle under each end of the machine. Remove the three long two by fours that attach to the support saddles.
7. On one side of the machine, remove the lag bolts holding the support saddle to the skid.
8. Using two of the two by fours as levers, carefully lift the end of the machine enough to allow the saddle to be removed from the skid and the machine to rest on its wheels.
9. Repeat Steps 7 and 8 for the other end of the machine.

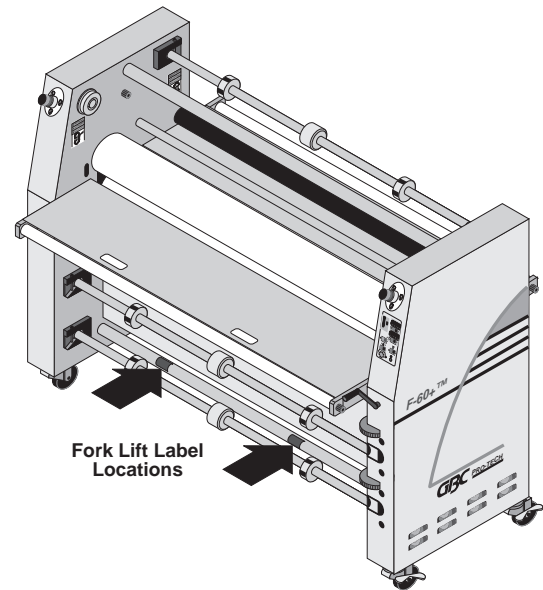

Figure 2-5: Fork Lift Blade Locations

12. Remove any plastic strapping and packing paper taped to the rolls.

**CAUTION**

Do not use a knife or other sharp instrument during installation or while servicing the laminator. You can cause irreparable damage to the rolls.

13. Remove all packing materials to a safe distance from the laminator.

☞ **A NOTE ABOUT RECYCLING**

The crate components can be reused for shipping the machine again, or can be disassembled and the wood and screws recycled. The shrink wrap is not recyclable, however, so it must be discarded.

- Level the laminator using the procedure later in this section.

Setup

Once the F-60+ Laminator has been unpacked and moved into final position check each of the following items.

Tools required:

- $\frac{1}{8}$ " hex wrench
- $\frac{7}{32}$ " hex wrench
- Adjustable wrench

Setup Procedure:

1. Inspect the laminator for any obvious shipping damage.
2. Using a $\frac{1}{8}$ " hex wrench, remove the screws securing the cabinet panel to the control (electrical) side of the machine.
3. Using a $\frac{7}{32}$ " hex wrench, remove the pull roll height adjust crank from the drive side of the machine.
4. Using a $\frac{1}{8}$ " hex wrench, remove the screws securing the cabinet panel to the drive side of the machine.
5. Inspect all the bolts and tighten any that were loosened during shipping.
6. Set the nip. (See *Maintenance* for the procedure.)
7. Replace both cabinet covers.
8. Replace the pull roll height adjust crank.

9. Using the $\frac{3}{8}$ " hex wrench, remove the bottom screws holding the rear table under the pull rolls. Collect the screws and spacers for reuse. Pivot the table up into position behind the pull rolls and secure in place by installing the bolts into the top set of cabinet holes. Be sure the spacers are in position!

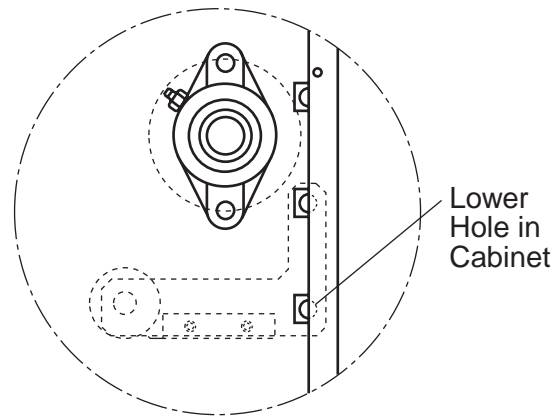

Figure 2-6: Installing the Rear Table

Leveling

Tools required:

- Adjustable wrench
- Carpenter's level

To level the laminator:

1. Raise each end, remove the castors and install a leveling pad and stud onto each of the foot brackets at the four bottom corners of the laminator. Thread third nut on stud above foot bracket.
2. Thread stud into 4 leveling pads lock down with nut. Thread second nut onto stud.
3. Place a carpenter's level front to rear across the two lower tie bars at one end of the machine.
4. Level this end of the machine front to rear, raising or lowering the leveling pads by adjusting the middle nuts on the foot bolts.
5. Move the level to the other end of the machine and level front to rear.
6. Place the level directly on one of the tie bars and level the machine side to side.
7. Recheck the front to rear level condition to insure that it has not changed. If it has, repeat the leveling procedure.
8. When all the measurements indicate that the machine is level, tighten down the top nuts on the foot brackets to lock the pads in their current position.

Startup

The first time the laminator is started and every time it is serviced you should use the following checklist to confirm that the unit is operating properly and that all safety mechanisms are functioning.

Startup Checklist

Start the laminator and go through the following checklist.

- Are the emergency stop buttons working?
Push down on one of the emergency stop buttons. The laminator should stop. Rotate and pull up on the button and push the reset button on the lower back of the laminator. The laminator should resume operation. Always check all buttons.



WARNING

Never operate the laminator unless all of the emergency stop buttons are functioning properly. You can be crushed or burned.

- Is the photoelectric eye system working?
With the laminator running, place an object approximately the size of your hand just in front of the nip to confirm that the photoelectric eye system is functioning. The rolls should stop. Move the object away from the nip. Press the RUN button on the front control panel. The laminator should resume operation.



WARNING

Never operate the laminator unless the mechanical guard system is operating properly. You can be crushed or burned.

- Is the footswitch working?
Press the footswitch. The laminator should start operation. Vary the speed using the footswitch (like an automobile accelerator) to ensure that the footswitch is operating properly at various speeds.

**WARNING**

Use extreme caution when operating the machine with the guard off. You can be crushed or burned.

- Is the motor functioning?
Test the motor at various speeds ranging from 0-15. At 0 the rolls should stop turning.
Run the motor in both forward and reverse.
- Are the heaters working?
Verify that the heater controller heats the top roll.

NOTE

The bottom roll heater controller must be turned on before the top roll heater controller will energize the top heater.

Once you have completed the startup checklist you can safely run a test sample.

Section 3 : Operation

Safety

The F-60+ Laminator has been designed with safety as a primary consideration. However, you must become thoroughly familiar with the controls, proper operation, proper service procedures, and safety features of the laminator before using or servicing the unit.

GBC Pro-Tech F-60+ Laminator is a powerful machine that is designed to mount, laminate and encapsulate. The forces required to accomplish these tasks can vary from negligible to very large.

In addition, the laminating roll of the F-60+ can reach temperatures of 270 °F (132 °C). At these temperatures there is a danger of a severe burn if the roll is touched during set-up, operation or servicing.

Safety is an important feature of the F-60+ Laminator. It has emergency stop buttons and a photoelectric eye system on the infeed.

The laminator is equipped with four emergency stop buttons located on the top front and back of either side of the laminator. Any of these, if engaged, stops the laminator. To continue operation all emergency stop buttons must be in the up position and you must press the reset button above the fuse panel on the back of the laminator (see Figure 3-2). The laminator is also equipped with a power lockout (see Figure 3-3) which stops power to the machine.

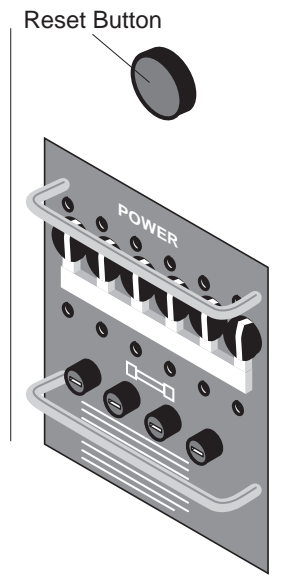

Figure 3-2: Resetting the Laminator

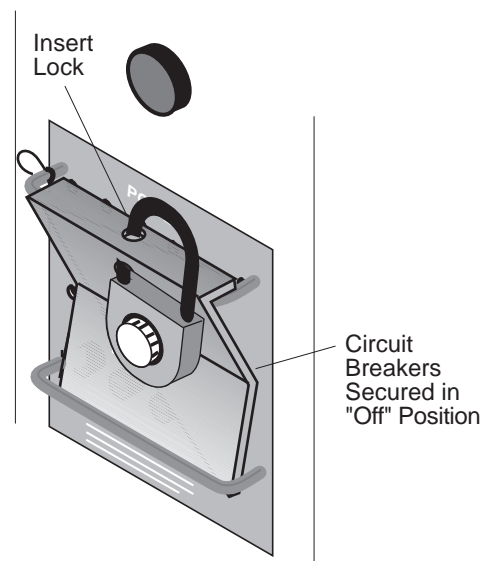

Figure 3-3: Power Lockout

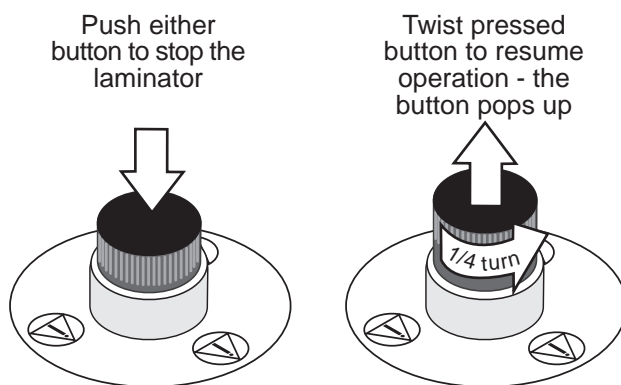

Figure 3-1: Using the Emergency Stop Buttons

Operator Controls

The operator controls for the F-60+ Laminator are located on the front and rear of the unit, to the right of the operator position. The names and functions of these controls are as follows:

Front Control Panel

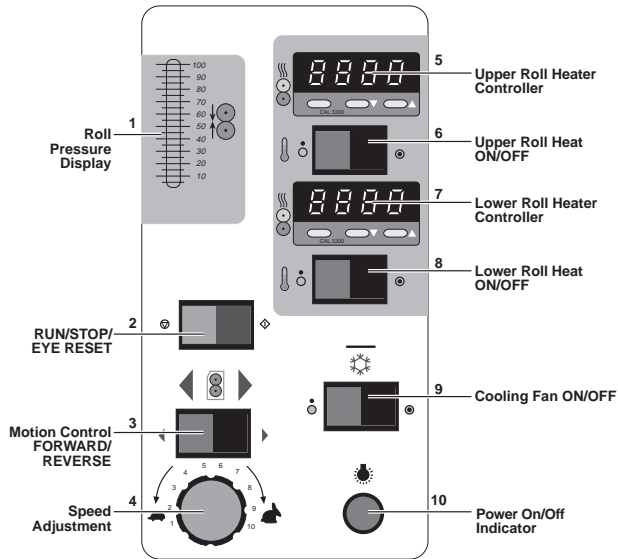

Figure 3-4: Front Control Panel

1. **ROLL PRESSURE DISPLAY** - Displays the percentage of force pushing the main laminating roll down.
2. **RUN/STOP/EYE RESET** – Turns the drive system on or off and resets the photoelectric eyes when in automatic forward mode. The photoelectric eyes do not function in reverse mode.
3. **MOTION CONTROL FORWARD/REVERSE** - Controls the direction of the drive system, forward, reverse, or stop.
4. **SPEED ADJUSTMENT** – Adjusts the speed of the machine from zero to the maximum as the control is turned clockwise. (Turtle is slow, rabbit is fast.)
5. **UPPER ROLL HEATER CONTROLLER** – Provides a readout of the temperature of the upper roll and the set-point for the desired temperature.

NOTE

The bottom roll heater controller must be turned on before the top roll heater controller will energize the top heater.

6. **UPPER ROLL HEAT ON/OFF** – Turns the heater controller for the upper main roll on or off.
7. **LOWER ROLL HEATER CONTROLLER**– Provides a readout of the temperature of the lower roll and the set-point for the desired temperature.
8. **LOWER ROLL HEAT ON/OFF** – Turns the heater controller for the lower main roll on or off.
9. **COOLING FAN ON/OFF** – Turns the cooling fan on or off.
10. **POWER ON/OFF INDICATOR** – Indicates when the main power is being applied to the machine.

Footswitch Operation

The footswitch can be used for feeding materials through the main rolls (forward mode). Material speed is controlled by the Control Panel Speed Adjustment knob, resulting in constant speed operation when the footswitch is pressed. The footswitch can also be used for feeding materials through the pull rolls (reverse mode). Material speed is controlled by the footswitch, which operates much like the accelerator on an automobile.



When the footswitch is used the photoelectric eye guarding the main rolls is turned off. Release the footswitch to stop the machine rolls.

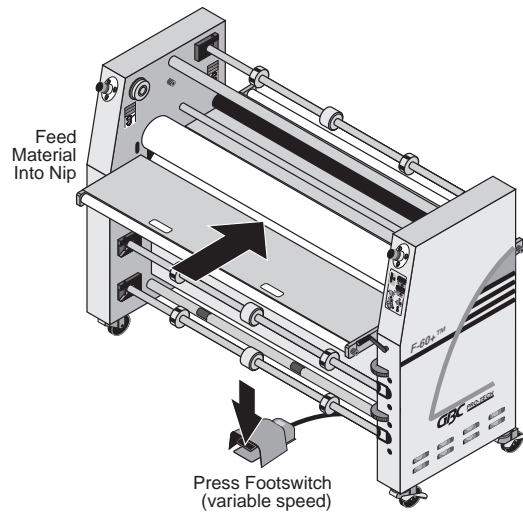

Figure 3-5: Using the Footswitch

Rear Control

The switch on the back of the drive cabinet starts and stops the main rolls when pressed while guards are in place.

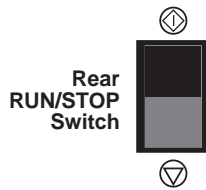

Figure 3-6: Rear RUN/STOP Switch

Setup

Setup of the F-60+ Laminator is quick and straightforward when instructions are followed exactly.

To adjust the nip, please see *Maintenance*.

Laminator Main Roll Pressure

Use only the minimum amount of roll pressure needed to accomplish the task. While higher pressure can make the adhesive bond faster, excess pressure can damage the rolls. Wrinkles and bubbles have causes that generally cannot be cured by applying more pressure.



CAUTION

**Excess pressure can damage the laminating rolls.
Minimum laminator roll pressure is consistent
with good results.**

A typical roll pressure for soft substrates such as Foam-core is between 30 to 40%.

The range of typical values for hard substrates is 30 to 50%.

Laminator Pull Roll Pressure

The F-60+ Laminator has an adjustable roll pressure for adjusting traction in the material across the width of the material using the pull roll height adjust crank. The same crank permits an infinite choice of gaps for board mount applications.

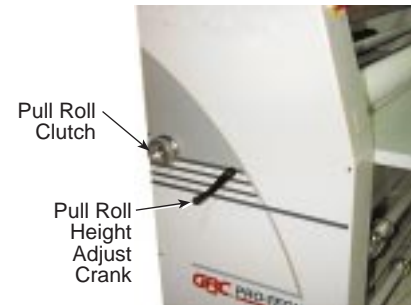

Figure 3-7: Pull Roll Clutch and Pull Roll Height Adjust Crank

Web Up Options

With the guard removed, move webs through the main roll nip by:

1. Pressing the RUN button for a slow, constant main roll rotation.
- or
2. Pressing the STOP button, then pressing the foot-switch to set the required speed. Releasing the footswitch stops main roll rotation.

Loading the Film

Film is loaded on the appropriate unwinds. Loading and aligning the film are discussed later in this section. For applications such as encapsulation, film is fed from both the top and bottom feed unwinds.

The process of loading and aligning film is the same for both the top and the bottom unwinds. There are two important points to remember when loading film:

1. The adhesive side of the film must be oriented away (on the outside) from the laminating roll. Otherwise it will immediately bond to the roll, creating a major clean-up project.

Films have a shiny side and a dull side. The dull side is the one with the adhesive. The dull side should **ALWAYS** face outward from the laminating roll.



CAUTION

Always mount the film so that the adhesive side faces outward from the laminating roll. This prevents hours of roll cleaning.

2. The film must be centered on the unwind for best performance. This is vital when two films are fed together. If the two films are not aligned, feed problems, wrinkles and other assorted troubles will occur.



CAUTION

Carefully align the two films being fed into the nip. If not, you will obtain poor results.

Recommended Materials

Films

The F-60+ Laminator is capable of processing a wide range of pressure sensitive and thermal laminates onto an equally wide range of image materials. The primary considerations are:

- Laminate adhesives are compatible with image materials.
- The materials properly activate below the maximum roll temperature and within the speed and roll nip pressure ranges available on the laminator.

It is the operator's responsibility to ensure the compatibility and operational settings for any laminates/image material combination. GBC Pro-Tech Technical Support is available at the number provided in the Maintenance chapter for advice on some material combinations.



CAUTION

Substituting materials can cause severe damage to your machine and is not recommended or covered under our warranty.

Positioning the Film

The following procedure is applicable to both the top and bottom feed unwinds.

1. Open the top unwind by removing the pin and swinging the arm out.
2. Load the film.
3. Return the arm to its locked position and reinsert the locking pin.
4. Center the film on the unwind arm by measuring the distance from the ends of the film to the sides of the machine using a tape measure.

Heating

Use the following instructions when heating one or both of the laminating rolls. The procedure is the same for the top and bottom heaters.

1. Set the heater switch to ON.
2. Adjust the temperature controller for the desired operating temperature using the temperature controller push buttons.
3. When heating the rolls, keep the top roll down and turning at a moderate speed to prevent uneven heating.
4. It will take approximately 30 minutes for the laminating roll(s) to reach operating temperature. When the preset operating temperature has been reached, the machine is ready to use.

Pull Roll Clutch Adjustment

The F-60+ Laminator has an adjustable clutch for the pull rolls on the machine, allowing you to adjust the amount that the film is tensioned as it leaves the main rolls and is cooled. The clutch adjustment is made by using the knob on the drive side of the machine.

Pull roll clutch tension adjustment:

Turning the knob clockwise increases tension.

Turning the knob counterclockwise decreases tension.



CAUTION

When the machine is not in use, the pull rolls must be raised to prevent damaging the rolls.

Paper Tips

Always feed prints perpendicular to the laminating rolls.

1. Lock core support to middle of the shaft. Lock two core chucks on shaft ends, located to support material a few inches from ends of the roll.

Note

Paper unwind may require two evenly spaced core supports if wide rolls of prints (paper) are used.

2. Place the roll on the unwind shaft.
3. Carefully close the unwind shaft, holding the roll away from the hinge.
4. When the shaft is in the saddle, push in the locking pin.
5. Center the roll of material.
6. Web and tension film per process control chart and diagram.

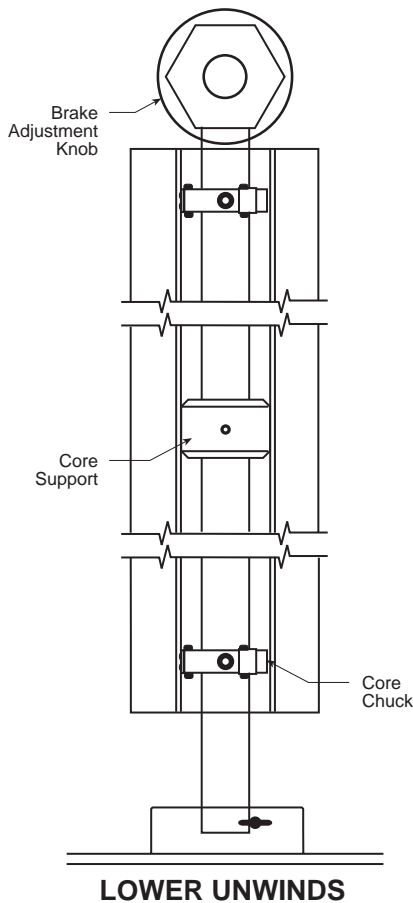

Figure 3-8: Brake Configuration

Process Control Charts

Process control charts allow you to record the way you thread film through the machine's rolls and idlers (called webbing) and the control settings for each product and process. Process control charts are an excellent tool for training new operators. They provide a "road map" for correct machine setup and operation.

This section contains a blank process control chart and diagram for the F-60+ as well as completed charts for the basic operations of the laminator.

GBC Pro-Tech laminators respond in a very accurate and repeatable manner. The charts provide a way to set up each time, every time for repeatable performance by assuring that all controls are set to optimum.

The process control charts should be kept in this manual or in a book close to the laminator. Use the machine to encapsulate the popular charts so they can withstand food and coffee spills and so they are always available for ready reference.

NOTE

When trying new products and processes, remember that GBC Pro-Tech's customer service representatives are only a phone call away.

The completed process control charts included in this section are based on Orca-Film and typical prints.

Mounting Only

Setup

1. See process chart 3-1.
2. Set the nip to the thickness of the material being used for mounting.
3. Upper Laminator Roll Pressure: 10–30%.
4. Speed: 3 fpm (1 m/min).
5. Upper Laminator Roll Heat: 240 °F (115 °C).

Procedure

1. Lay the print on the board. Using a tack iron, tack the leading edge of the print down onto the board so it is held in place.
2. Put a piece of contact/release paper over the print and board. Otherwise, adhesive will be applied to the laminating roll, which can cause damage and the ink from electrostatic prints will be deposited on the roll.
3. Feed the print/board package through the nip.

Mounting/Laminating

The following procedure is for one-step mounting and heat-activated laminating using mounting board with one adhesive side.

Setup

1. See process chart 3-2.
2. Mount the film and web as shown in diagram 3-2.
3. Set the nip for the substrate thickness by raising or lowering the upper main roll using the hand crank.
4. Laminator Roll Pressure: 10–30%.
5. Speed: 3 fpm (1 m/min).
6. Upper Laminator Roll Heat: 240 °F (115 °C).

Procedure

1. Lay the print on the board. Using a tack iron, tack the leading edge of the print down onto the board so it is held in place.
2. Feed the print/board package through the nip.

Encapsulation**Setup**

1. See process chart 3-3.
2. Laminating Roll Pressure: 30-40%.
3. Speed: 0-6 fpm (0-180 cpm).
4. Upper Laminator Roll Heat: 230 °F (110 °C).
5. Lower Laminator Roll Heat: 32 °F (0 °C).
6. Cooling: Optional.
7. Use of the rear wind-up roll for the finished material is optional. It is a good procedure for long runs.

Procedure

Feed the work into the nip with the leading edge tight and entering the nip evenly from side to side. For thin paper from electrostatic printers in roll form it is best to fold over the leading edge approximately 6 inches to create a square leading edge.

Two-Pass Mount and Laminate (Hot and Cold)

There are several approaches to the mount/laminate task. It can be accomplished with either hot or cold laminate film on the top. Also, the second pass for mounting can be done by feeding from either the front or back of the laminator.

Setup

See process charts 3-4, 3-5A & B, and 3-6A & B for film mounting instructions and machine adjustments.

Procedure, Pass 1

1. Run the print through to apply adhesive and laminate.
2. Trim to slightly larger than the desired finished size.

Procedure, Pass 2

1. Prepare to put the print through a second time to mount the print to the substrate - anything from wood, to Masinote, to Gator foam. Start by setting the shims to the appropriate spacing for the material used.
2. Trim the board to the size of the print.
3. Align the work to the board and ensure an exact fit. Place weights on the center of the print to make sure that it does not move relative to the board during the next steps.
4. Raise one end of the print and peel back approximately two inches of the liner to expose the adhesive that was applied to the print in the first pass. Fold it under.
5. Lay the print back down evenly and extremely flat. From the center outward, tack the exposed adhesive to the substrate.
6. Position the piece so that the end with the liner peeled back is facing the nip. Insert the first one inch of the board into the nip. Very carefully wrap the print back and over the top laminating roll. Be sure there are no wrinkles in the nip area. Carefully peel off the liner as the board progresses through the laminator.
7. Trim the piece to the finished size.

PROCESS CONTROL CHART

Product: _____ Process: _____ Date: _____

FRONT CONTROL SETTINGS	
Speed:	Reverse/Forward:
Roll Pressure:	Top Heater:
Cooling:	Bottom Heater:

PROCESS CONTROL DIAGRAM

Identification Diagram

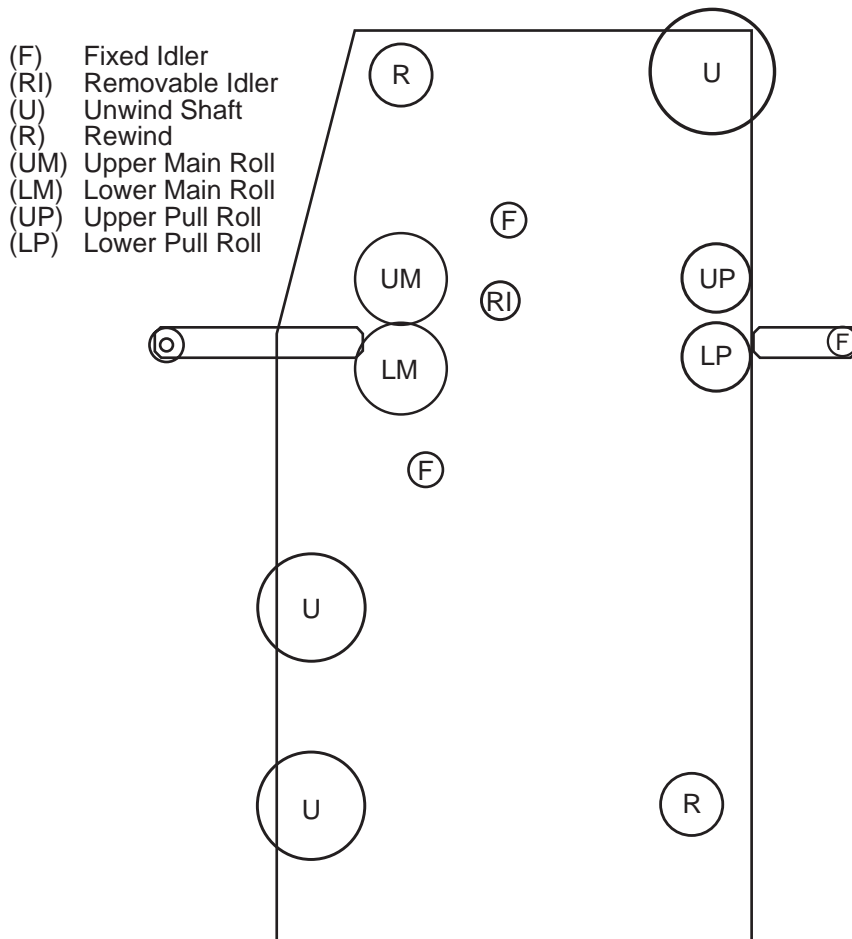

PROCESS CONTROL CHART 3-1

Product: _____ Process: One Pass Mounting Date: _____

FRONT CONTROL SETTINGS	
Speed: 2-3 fpm (60-90 cpm)	Reverse/Forward: Forward
Roll Pressure: Trial	Top Heater: 240 °F (115 °C)
Cooling: Off	Bottom Heater: 32 °F (0 °C)

PROCESS CONTROL DIAGRAM 3-1

One Pass Mounting

NOTE

Footswitch may be used.

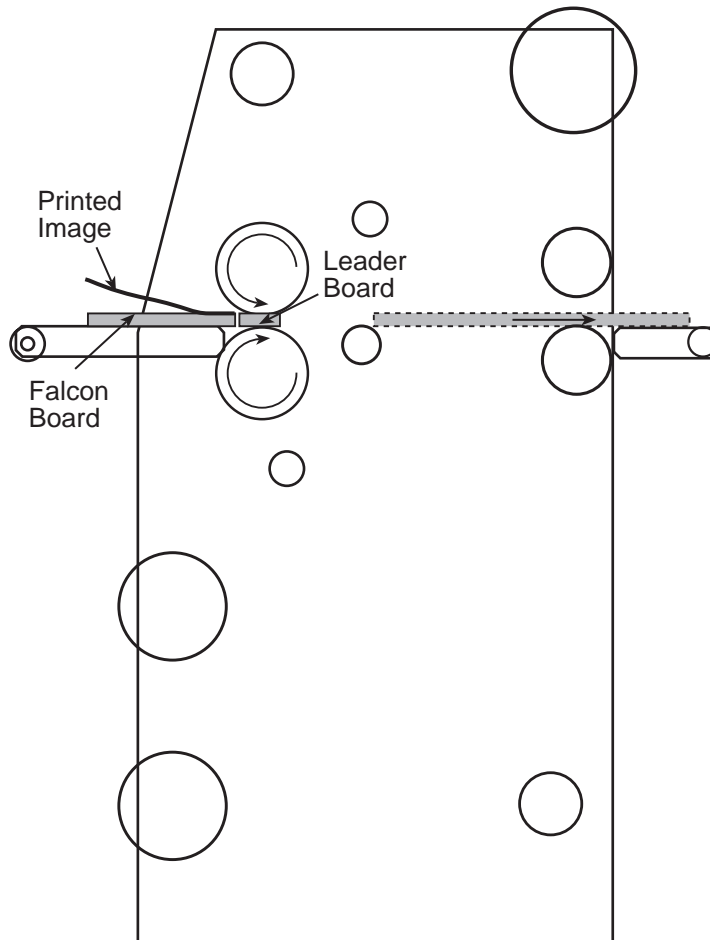

PROCESS CONTROL CHART 3-2

Product: _____ Process: One Pass Mount & Laminate Date: _____

FRONT CONTROL SETTINGS	
Speed: 1-2 fpm (30-60 cpm)	Reverse/Forward: Forward
Roll Pressure: Trial	Top Heater: 240 °F (115 °C)
Cooling: Off	Bottom Heater: 32 °F (0 °C)

PROCESS CONTROL DIAGRAM 3-2

One Pass Mount and Laminate

☞ **NOTE**

Footswitch may be used.

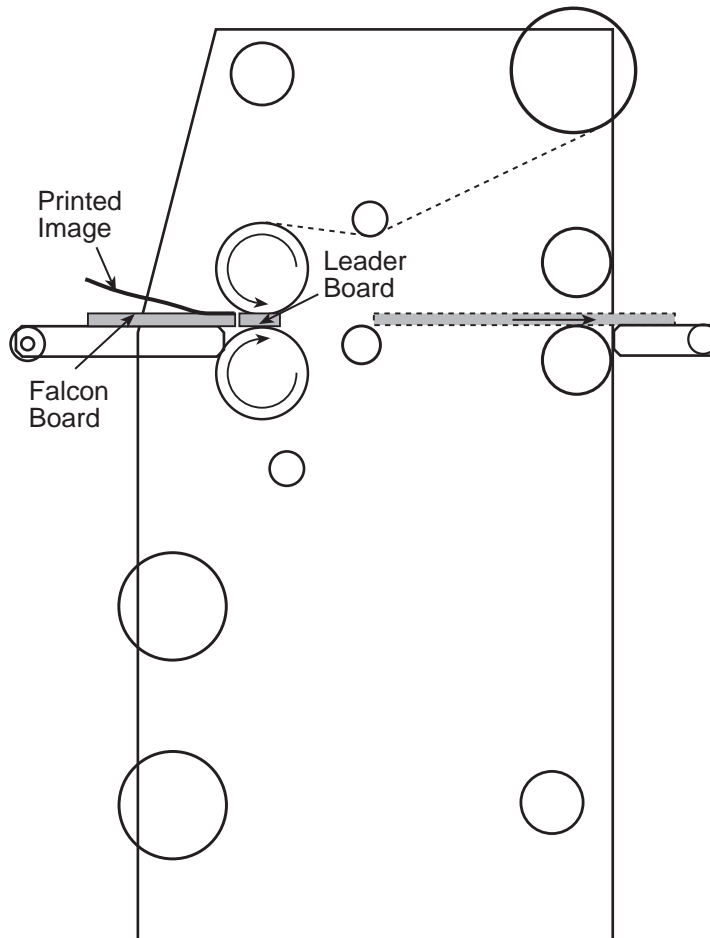

PROCESS CONTROL CHART 3-3

Product: 3 Mil Gloss/3Mil Gloss Process: Encapsulation Date: _____

FRONT CONTROL SETTINGS	
Speed: 0-6 fpm (0-180 cpm)	Reverse/Forward: Forward
Roll Pressure: 30-60%	Top Heater: 230 °F (110 °C)
Cooling: Optional	Bottom Heater: 230 °F (110 °C)

PROCESS CONTROL DIAGRAM 3-3

Encapsulation

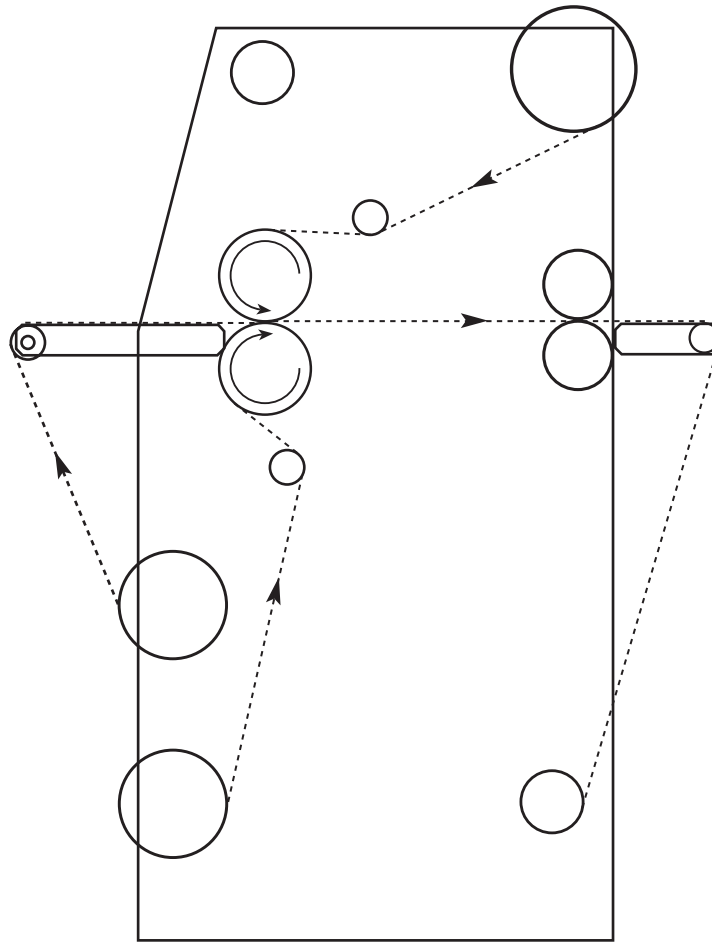

PROCESS CONTROL CHART 3-4

Product: _____ Process: Cold Overlamination _____ Date: _____

FRONT CONTROL SETTINGS	
Speed: 0-6 fpm (0-180 cpm)	Reverse/Forward: Forward
Roll Pressure: 30-60%	Top Heater: 105 °F (40 °C)
Cooling: Off	Bottom Heater: 32 °F (0 °C)

PROCESS CONTROL DIAGRAM 3-4

Cold Overlamination

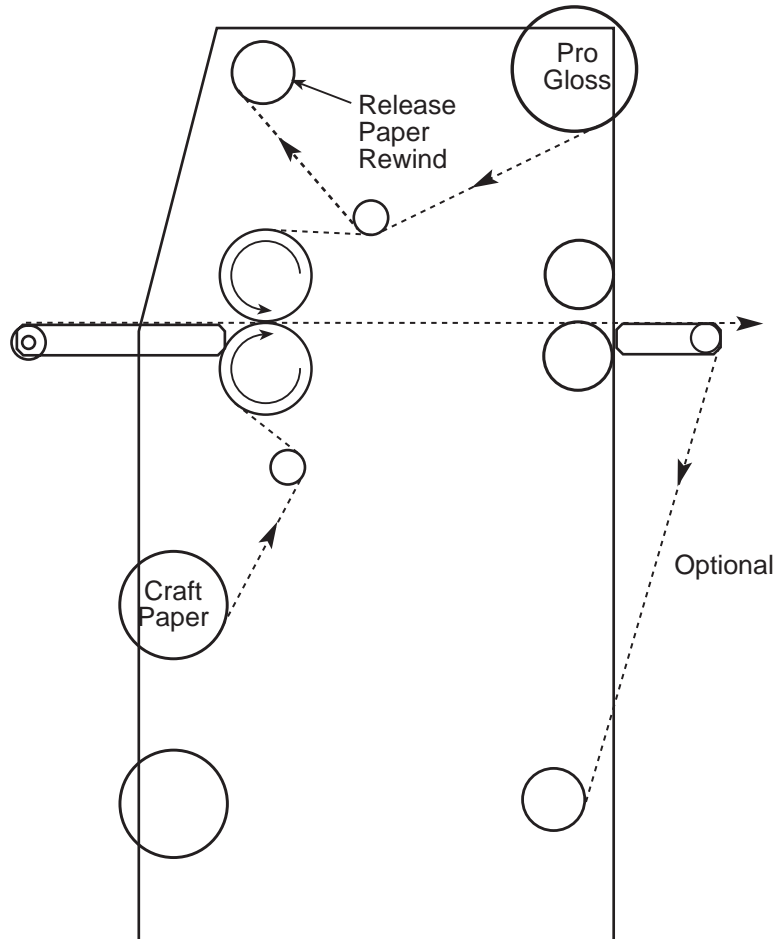

PROCESS CONTROL CHART 3-5A

Product: _____ Process: Cold Mount & Laminate (First Pass) Date: _____

FRONT CONTROL SETTINGS	
Speed: 0-6 fpm (180 cpm)	Reverse/Forward: Forward
Roll Pressure: 30-60%	Top Heater: 105 °F (40 °C)
Cooling: Off	Bottom Heater: 32 °F (0 °C)

PROCESS CONTROL DIAGRAM 3-5A

Cold Mount and Laminate (First Pass)

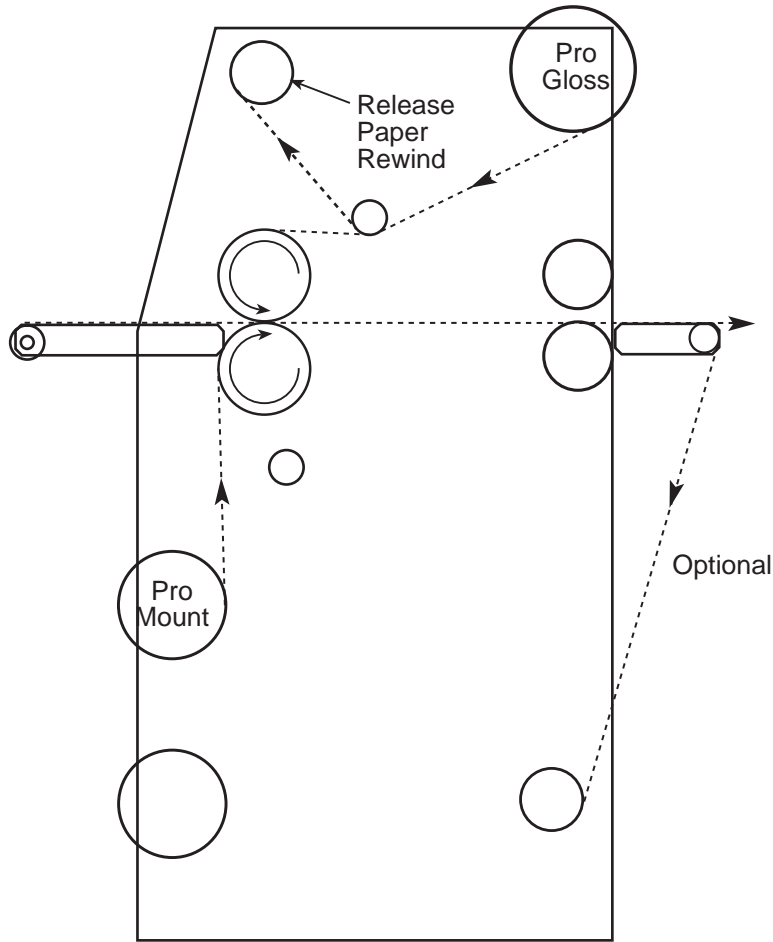

PROCESS CONTROL CHART 3-5B

Product: _____ Process: Cold Mount & Laminate (Second Pass) Date: _____

FRONT CONTROL SETTINGS	
Speed: 0-6 fpm (0-180 cpm)	Reverse/Forward: Forward
Roll Pressure: Trial	Top Heater: 32-105 °F (0-40 °C)
Cooling: Off	Bottom Heater: 32 °F (0 °C)

PROCESS CONTROL DIAGRAM 3-5B

Cold Mount and Laminate (Second Pass)

NOTE

Use footswitch to load, then accelerate materials through rolls.

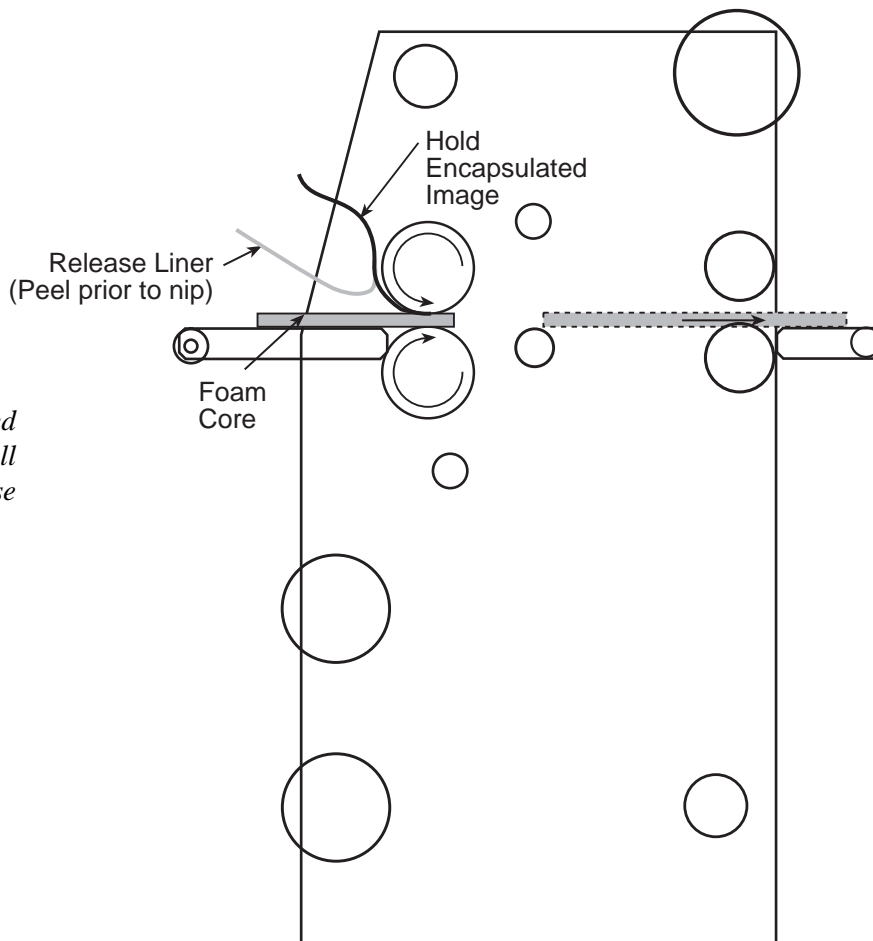

OPTIONAL

Board can be fed through the pull rolls using reverse mode.

PROCESS CONTROL CHART 3-6A

Product: _____ Process: Mount & Hot Overlamine (First Pass) Date: _____

FRONT CONTROL SETTINGS	
Speed: 0-6 fpm (0-180 cpm)	Reverse/Forward: Forward
Roll Pressure: 30-60%	Top Heater: 230 °F (110 °C)
Cooling: Optional	Bottom Heater: 32 °F (0 °C)

PROCESS CONTROL DIAGRAM 3-6A

Mount and Hot Overlamine (First Pass)

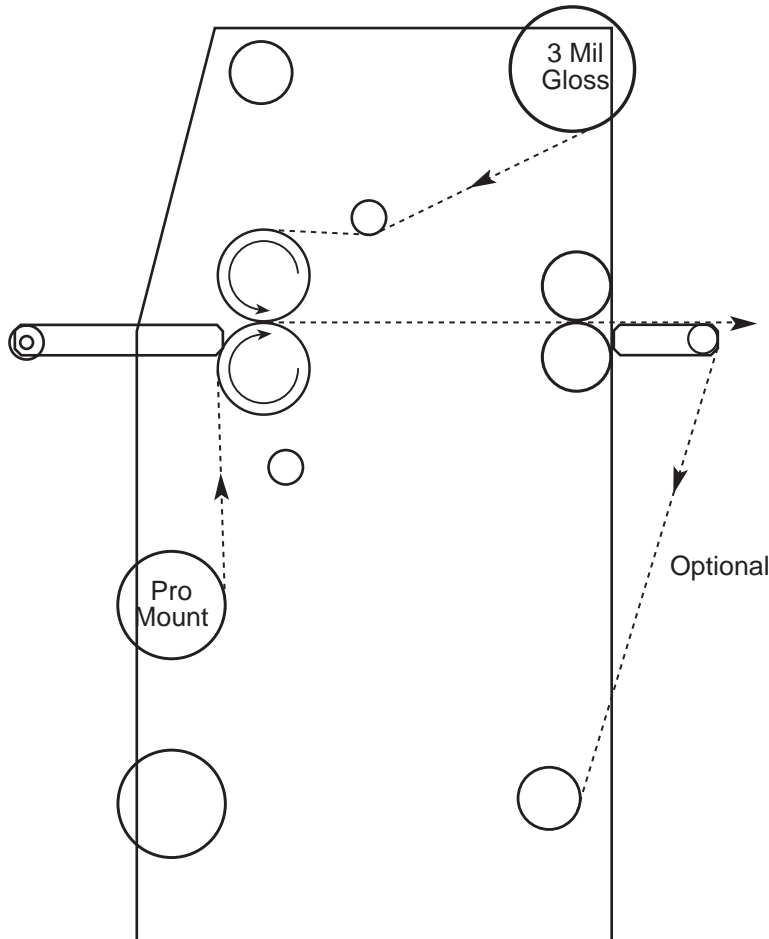

PROCESS CONTROL CHART 3-6B

Product: _____ Process: Mount & Hot Overlamine (Second Pass) Date: _____

FRONT CONTROL SETTINGS	
Speed : 0-6 fpm (0-180 cpm)	Reverse/Forward: Forward
Roll Pressure: Trial	Top Heater: 32-105 °F (0-40 °C)
Cooling: Off	Bottom Heater: 32 °F (0 °C)

PROCESS CONTROL DIAGRAM 3-6B

Mount and Hot Overlamine (Second Pass)

NOTE

Use footswitch to load, then accelerate materials through rolls.

OPTIONAL

Board can be fed through the pull rolls using reverse mode.

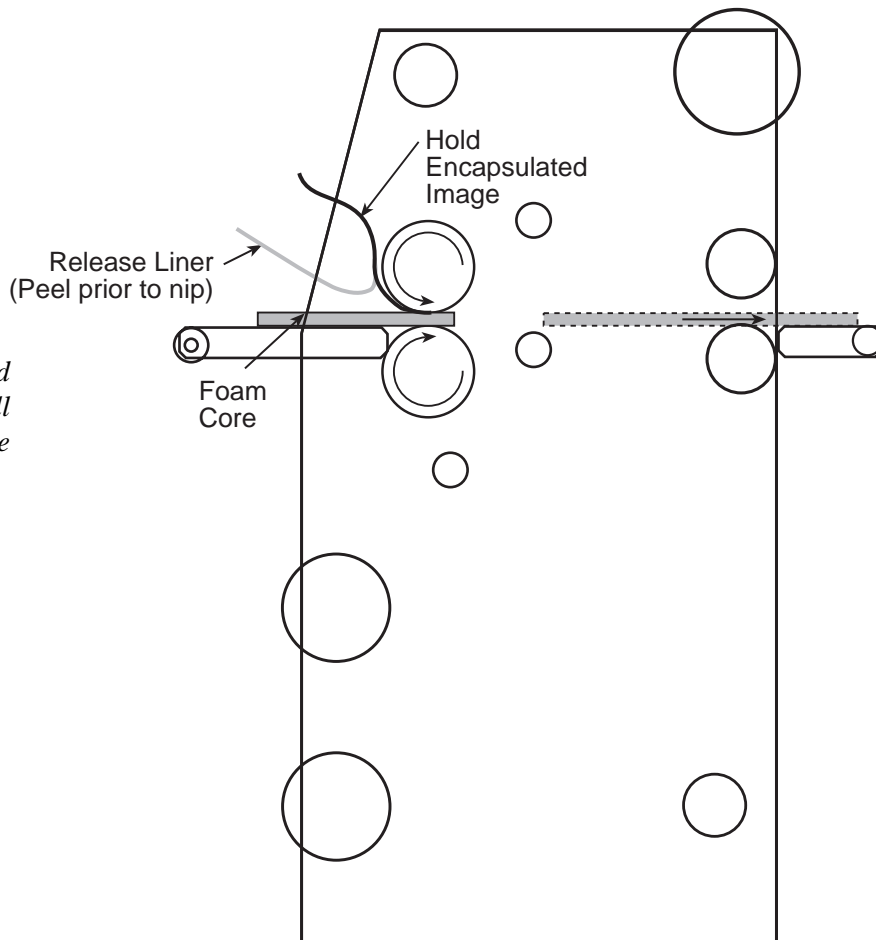

Blank page.

Section 4 : Maintenance and Troubleshooting

GBC Pro-Tech laminators require minimal maintenance. However, regular maintenance is essential to keep any piece of precision machinery at peak performance. A maintenance schedule and a section of procedures are included in this section.

Table 4-1: Maintenance Schedule

Daily	<ul style="list-style-type: none"> • Clean the rolls • Inspect the electrical cord for damage • Inspect the footswitch cord for damage
Monthly	<ul style="list-style-type: none"> • Adjust the nip • Check the chain tension • Inspect the area around the laminator for possible hazards (dust buildup, combustible items stored too close, etc.)
Every Six Months	<ul style="list-style-type: none"> • Lubricate the grease fittings and chain • Check wire termination tightness

Cleaning

Tools required:

- Adhesive coated board
- 80% isopropyl alcohol (or dishwashing detergent)
- Rubber cement eraser
- Several 100% lint free paper or cotton terry cloths
- Protective rubber gloves

To remove heat activated adhesive from laminator rolls:



Exercise extreme caution while cleaning the laminator. You can be caught in the turning rolls and crushed or burned.

While the laminator is still at normal operating temperature (200-250 °F), put on the rubber gloves and, using a rubber cement eraser, remove any heat activated adhesive from the rolls. Use “footswitch mode” and slow speed to rotate the rolls in reverse.



If silicone adhesive contacts the upper or lower roll, remove it IMMEDIATELY using a rubber cement eraser. It can harden within an hour and ruin the roll.



Do NOT pick or pull heat activated adhesive off the rolls when they are cold. You can cause irreparable damage to the laminating rolls.



Do not use compressed air to clean the machine. Blowing debris can be forced into places where it will later ignite or short electric circuits.

To clean beads of adhesive, dust and dirt from the rolls:

1. Allow the laminator to cool slightly to no higher than 110°F (43°C).
2. Set the FWD/REV switch to the REV position.
3. Clean the rolls using a moderate amount of 80% isopropyl alcohol on a cotton terry cloth.



CAUTION

Use the minimum amount of pressure necessary to clean the rolls. You can destroy the silicone layer on the rolls by pressing too hard or scrubbing too long in one spot.



WARNING

Exercise care when cleaning the rolls with 80% isopropyl alcohol:

- Use only in a well ventilated area.
 - Wear rubber gloves.
 - Use only on cool rolls.

Cleaning heated rolls can ignite the fumes.



CAUTION

Use only 80% isopropyl alcohol or a rubber cement eraser to clean the laminating rolls. Harsh chemicals like toluene, acetone or MEK destroy the silicone covering of the rolls.

4. With the laminator rolls no hotter than 110°F, remove dust and dirt from the silicone laminating rolls by running an adhesive-coated board through the laminator. Be sure to set the nip for the thickness of the board used.
5. Allow the laminator to cool.

To clean the cabinet and covers:



WARNING

Remove and lockout power from the laminator while you are performing this procedure. You could be severely shocked, electrocuted, or get your fingers caught in the drive mechanisms.

1. Using a damp cotton terry cloth (water only), clean the exterior of the laminator.



WARNING

Do not use liquid or aerosol cleaners on the laminator. Do not spill liquid of any kind on the laminator. You can be severely shocked, electrocuted or cause a fire. Use only a damp cloth for cleaning.

Adjusting the Nip

The gap between two rolls is called the nip. The purpose of adjusting the nip is to ensure continuous contact between the rolls as the media is drawn through the machine. This procedure must be done regularly for the main rolls. It is not necessary to set the nip on the pull rolls.

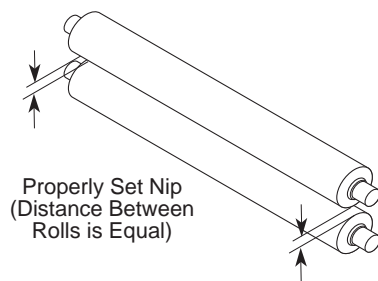

Figure 4-1: Properly Set Nip

Tools required:

- 1/8" hex wrench
- 3/4" hex wrench

To adjust the main roll nip:



The main roll must be at room temperature to achieve a proper nip setting.

1. Remove the left side cabinet cover with the 1/8" hex wrench by removing the seven screws holding the cover in place. Gently rotate the cover around the clutch knob to allow access to the roll lift system.
2. Lower the upper main roll so that there is a small visible gap between it and the lower main roll.
3. Loosen the 3/4" jam nut securing the lift assembly bolt. Adjust the nip by rotating the lift assembly bolt clockwise to raise the end being adjusted and counterclockwise to lower it.

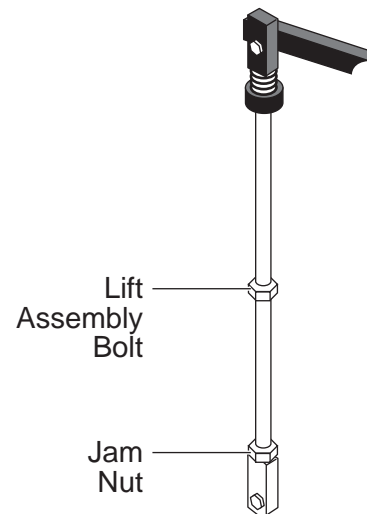

Figure 4-2: Nip Setting Assembly

4. Adjust the nip so that there is an even line of light across the width of the rolls.
5. Secure the jam nut on the lift assembly bolt.
6. Replace the cabinet cover.

Chain Tensioning

Smaller chain tensioning adjustments on the F-60+ Laminator are handled by a secondary chain tensioner, however, when installing a new chain or when the chain tension is more seriously out of adjustment, use the following procedure to adjust the chain tension.

Tools required:

- $\frac{1}{8}$ " hex wrench
- $\frac{7}{32}$ " hex wrench
- $\frac{3}{16}$ " hex wrench
- Screwdriver

To adjust the chain tension:



WARNING

Remove and lockout power from the laminator while you are performing this procedure. You could be severely shocked, electrocuted, or get your fingers caught in the drive mechanisms.

1. Remove the drive side cabinet cover using the $\frac{1}{8}$ " hex wrench by removing the seven screws holding the cover in place.
2. Using a $\frac{7}{32}$ " hex wrench, remove the pull roll height adjust crank from the drive side of the machine.
3. Loosen the top rewind chain tensioner.
4. Loosen all four motor mount bolts using the $\frac{3}{16}$ " hex wrench as shown in the figure below. The motor should just move freely within the slots.

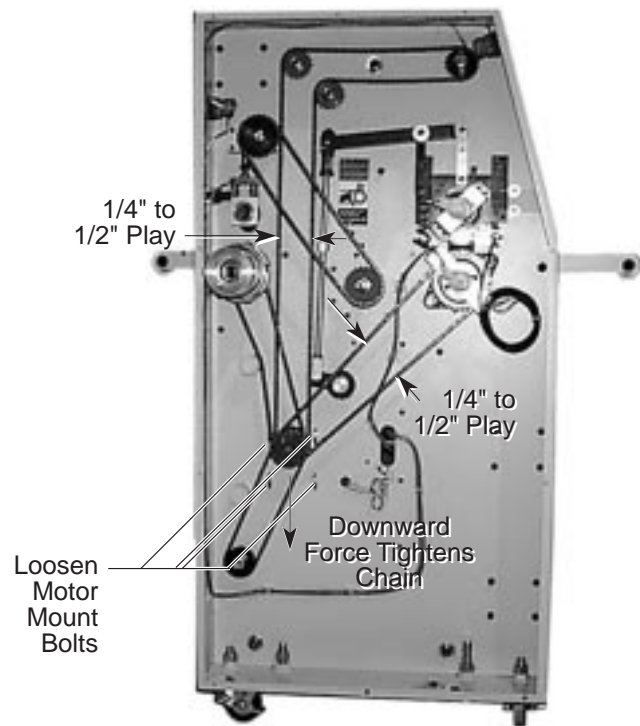

Figure 4-3: Adjusting the Chain Tension

5. Using a screwdriver, apply a small amount of downward pressure on the motor by prying against the inside of the side frame until there is $\frac{1}{4}$ " to $\frac{1}{2}$ " play in the chain.
6. Tighten the mounting bolts while maintaining the downward pressure on the motor.
7. Engage the top rewind chain tensioner and apply pressure until its chain exhibits similar tension to the primary chain tensioner.
8. Engage the bottom rewind chain tensioner and apply pressure until its chain exhibits similar tension to the primary chain tensioner.
9. Replace the cabinet cover.
10. Replace the pull roll height adjust crank.
11. Reapply power to the laminator.

Lubrication

Tools required:

- $\frac{1}{8}$ " hex wrench
- High temperature grease or lithium grease
- Grease gun

To lubricate the laminator:



Do not lubricate the laminator when it is hot. You can be burned.



Remove and lockout power from the laminator while you are performing this procedure. You could be severely shocked, electrocuted, or get your fingers caught in the drive mechanisms.

1. Remove the drive and control side cabinet covers using the $\frac{1}{8}$ " hex wrench by removing the seven screws holding each cover in place. Gently rotate the cover around the clutch knob to allow access to the lubrication points.
2. Using the grease gun, lubricate each grease fitting with one squirt of high temperature grease.
3. Lubricate the chain using a soft cloth and automotive oil.
4. Replace the cabinet covers, close the safety shields and reapply power to the laminator.

Contacting Technical Support

For machine parts and technical service in North America, please call: 1-800-790-7787. **Please provide serial number when calling for service.** In Europe, please call: +44 (0) 1844 202 440 or fax: +44 (0) 1844 202 441.

For film and application questions in North America, please call 1-800-236-8843. In Europe, please call: +44 (0) 1844 202 440 or fax: +44 (0) 1844 202 441.

Output Troubleshooting Guide

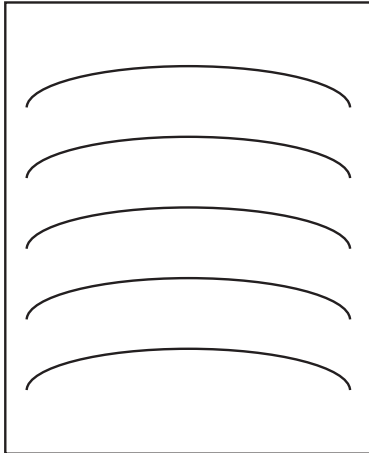

Problem:
D waves in the image, not in the laminate.

Hints:

- Check paper tension.
- Check relative moisture content of the paper.

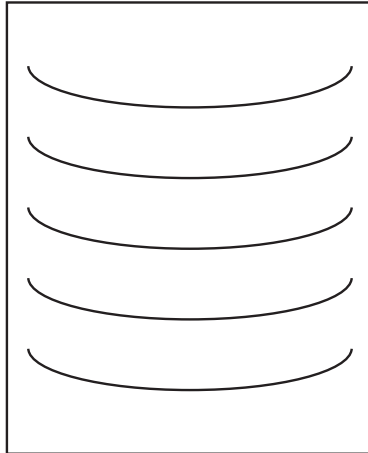

Problem:
D waves in the laminate.

Hints:

- Increase clutch tension.
- Check roll pressures.
- Check nip settings.

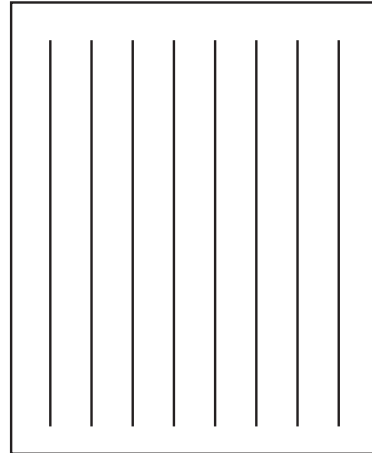

Problem:
Straight waves in the output.

Hints:

- Decrease clutch tension.
- Check operational settings for materials being used.

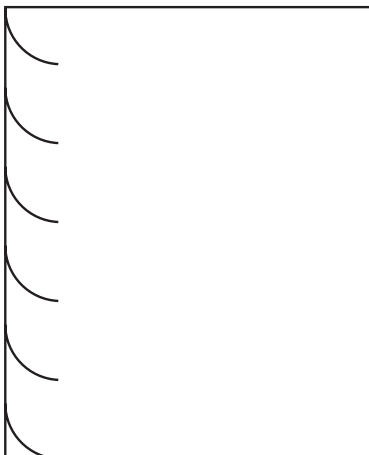

Problem:
Waves on only one side of the output.

Hints:

- Check nip settings.
- Check for even paper tension.

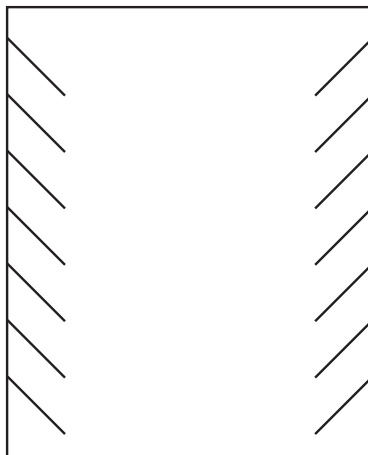

Problem:
Angled waves on the output.

Hints:

- Check for insufficient clutch tension.
- Check for insufficient main roll pressure

Feed Direction



Other Common Problems:

Problem:
Blistering in the image.

Hints:

- Increase speed or lower the operating temperature.

Problem:
Coiling of encapsulated images.

Hints:

- Balance the upper and lower unwind brake tension. Make sure main roll temperatures are the same. Adjust cooling fans.

Problem:
Longitudinal waves or stuttering, jerking, or excessive noise from the drive side of the laminator.

Hints:

- Increase chain tension, decrease unwind brake tension.

Section 5 : Warranty

Limited Warranty

GBC Pro-Tech Engineering Company, Inc. warrants the equipment sold is free from defects in material and workmanship for a period of ninety days (90) **from the date of delivery** to the customer. This warranty is the only warranty made by GBC Pro-Tech and cannot be modified or amended.

GBC Pro-Tech's sole and exclusive liability and the customer's sole and exclusive remedy under this warranty shall be, at GBC Pro-Tech's option, to repair or replace any such defective part or product. These remedies are only available if GBC Pro-Tech's examination of the product discloses to GBC Pro-Tech's satisfaction that such defects actually exist and were not caused by misuse, neglect, attempt to repair, unauthorized alteration or modification, incorrect line voltage, contaminated air supply, or by fire, accident, flood, or other hazard.

This warranty specifically does not cover damage to the laminating rollers caused by knives, razor blades, other sharp objects, failure caused by adhesives or improper use of the machine. Warranty repair or replacement does not extend the warranty beyond the initial ninety day period from the date of delivery.



CAUTION

Unauthorized customer alterations will void this warranty.

THE WARRANTY MADE HEREIN IS IN LIEU OF ALL OTHER WARRANTIES, EXPRESS OR IMPLIED, INCLUDING ANY WARRANTY OR MERCHANTABILITY OR FITNESS FOR A PARTICULAR PURPOSE. GBC PRO-TECH WILL NOT BE LIABLE FOR PROPERTY DAMAGE OR PERSONAL INJURY (UNLESS PRIMARILY CAUSED BY ITS NEGLIGENCE), LOSS OF PROFIT OR OTHER INCIDENTAL OR CONSEQUENTIAL DAMAGES ARISING OUT OF THE USE OR INABILITY TO USE THE EQUIPMENT.

Exclusions to the Warranty

This warranty specifically does not cover:

1. Damage to the laminating rolls caused by knives, razor blades, other sharp objects, or failure caused by adhesives.
2. Damage to the machine caused by lifting, tilting, and/or any attempt to position the machine other than rolling on the installed casters on even surfaces.
3. Improper use of the machine.

Blank page.

Section 6 : Specifications, Parts and Schematic

Table 6-1: F-60+ Laminator Specifications

Characteristic	Specifications
Dimensions (L x D x H)	Uncrated: 80" x 38.5" x 57" (202 x 84 x 145 cm) Crated: 90" x 44" x 68" (202 x 84 x 145 cm)
Weight	Uncrated: 1200 lbs (544 kg) Crated :1700 lbs (771 kg)
Laminating Rolls	64" (163 cm) roll face with a high release surface, upper and lower rolls internally heated.
Laminating Material	Uses pressure sensitive materials up to 62 inches (158 cm) wide and hot/heat activated materials up to 61 inches (155 cm) wide on a 3-inch (7.6 cm) inside diameter core, maximum roll diameter of 10 inches (25.4 cm).
Laminating Speeds	0 to 15 fmp (0 to 4.57 mpm) with variable speed, reversible action at slow speed (less than 3 ft/min (1 m/min)), start and stop controlled either through the instrument panel or with the variable speed footswitch.
Heating	Capable of operating temperatures of up to 270 °F (132 °C).
Safety Features	<ul style="list-style-type: none"> • Redundant circuit protected safety shielding • Photoelectric eye protected on the infeed side of the main nipping rolls • Four emergency stop buttons
Installation Requirement	60A single phase, 220/230/240 VAC or, in Europe, 3 Phase, 240 VAC with 30 Amps per phase.

Table 6-2: Replacement Parts

Part Number	Description	Recommended Quantity
001-374	Assembly, Force Gauge PCB	1
001-505	Assembly, Force Sensor	1
001-515	Assembly, Control PCB	1
186-200	Fuse, SB, 3AG, 3A	3
214-313	Switch, Palm, E-stop	1
230-007	Temperature Control	1
425-003	Motor	1
690-059	Roll, Rubber	1
189-032	Heater, Round	1
230-006	IR Sensor	1
860-014	Tube, Rewind Brake	1
186-135	Fuse, 250V, 20A, Ceramic	1
690-052	Roll, Pull, Upper	1
690-053	Roll, Pull, Lower	1

Blank page.

Section 7: Index**A**

Accessory pack 2-5
Adjusting
 nip 4-3

C

Chain
 Lubrication 4-5
 Tensioning 4-4
Cleaning 4-1
Controls
 front control panel 3-2

E

Emergency stop buttons 1-1, 2-7, 3-1
Encapsulation 3-7
Environment 2-1
Extension cord 2-1

F

Film 3-4
 loading 3-4
 positioning 3-4
Footswitch 3-2, 4-1, 6-1
FWD/REV switch 4-2

G

Grease fittings 4-5
Ground plug 2-1

H

Heater 2-8
 Controller 2-8
Heaters
 Installing 2-6
Heating 3-5

I

Installation requirements 2-1, 6-1
Isopropyl alcohol 4-1

L

Laminate adhesives 3-4
Laminating material 6-1
Laminating rolls 6-1

Laminating speeds 6-1
Leveling 2-7
Lubrication 4-5

M

Main rolls 4-3
Maintenance schedule 4-1
Motor 2-8, 4-4
Mounting 3-6
Mounting/Laminating 3-7

N

Nip 1-2, 2-6, 4-1, 4-2, 4-3

P

Paper 3-5
Power cord 2-1
Power requirement 2-1
Preinstallation checklist 2-1
Pressure
 laminator roll 3-3
Process control charts 3-6
Pull roll
 clutch adjustment 3-5

R

Resetting the laminator 1-1, 3-1
Riggers 1-3, 2-5
Rubber cement eraser 4-1

S

Safety features 6-1
Safety information 1-1
Safety labels 1-3
Setup 3-3
Setup procedure 2-6
Specifications
 Dimensions 6-1
 Laminating material 6-1
 Laminating rolls 6-1
 Laminating speeds 6-1
 Weight 6-1
Startup checklist 2-7

T

Technical support
 Call 1-800-236-8843 4-5
Two-pass mount and laminate 3-7

U

Unpacking 2-4

 Crate 2-4

Upper main roll 1-3

W

Warnings and cautions 1-1

Warranty 5-1