

8.0 PARTS LIST - MP2500iX ELECTRIC PUNCH

8.1 Parts Listing, Machine Front Assembly

Index	Part Number	Description	Qty
1	1902828	SCREW, 8-32 x .75 PHIL PAN HEAD	1
2	1908801	SCREW, 10-32 x 1.0 F.H. SOCKET SCREW	8
3	1929606	PLASTIC RIVET	2
4	7704306	ENDCAP, RIGHT	1
5	7704307	ENDCAP, LEFT	1
6	7704314	DECK, BACK	1
7	7704320	DECK, FRONT	1
8	7704336	SWITCH, START	1
9	7704348	PLATE, EDGE GUIDE ADJUSTMENT	1
10	7704349	PCB, LED, MODULAR PUNCH	1
11	7704364	LABEL, BLACK	2
12	7704369	WIRE RETAINER	1
13	7704441	LABEL, MAIN DECK	1
14	7704446	LED BOARD COVER	1
15	7704495	CABLE ASSEMBLY, RUN SWITCH	1
16	7704497	CABLE ASSEMBLY, LED BOARD	1

8.0 PARTS LIST - MP2500iX ELECTRIC PUNCH

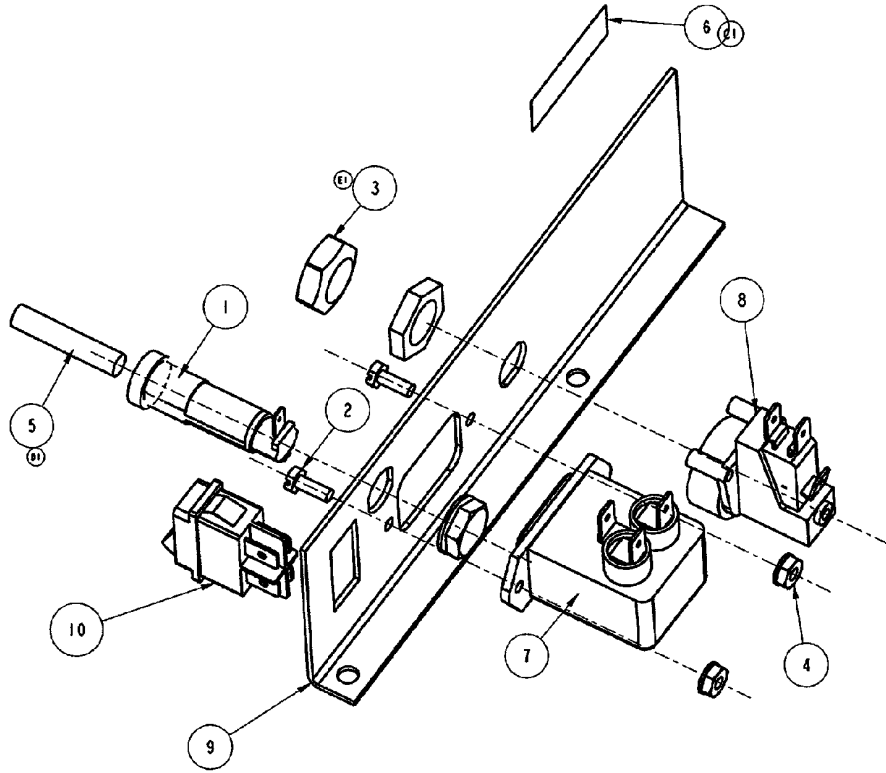

8.2 Parts Listing, Power Switch Assembly

Index	Part Number	Description	Qty
1	1132343	FUSE HOLDER, 115V	1
1	1155063	FUSE HOLDER, 230V	1
2	1907301	SCREW, 6-32 x .38 SLOT HEX HD	2
3	1926612	NUT 1/2 -20	1
4	1926801	NUT, 6-32 KEPS	2
5	1970120	FUSE, 3A, 250V (for use with 115V model)	1
5	1970122	FUSE, 2 A, 250V (for use with 230V model)	1
6	6009402	LABEL, FUSE, 3A, 250V	1
6	1963906	LABEL, FUSE, 2A, 250V	1
7	6195001	SOCKET, POWER LINE, RFI FILTER 115V & 230V	1
8	6202046	SWITCH, PNEUMATIC	1
9	7704354	BRACKET, ELECTRICAL MOUNTING	1
10	7704376	ROCKER SWITCH	1

8.0 PARTS LIST - MP2500iX ELECTRIC PUNCH

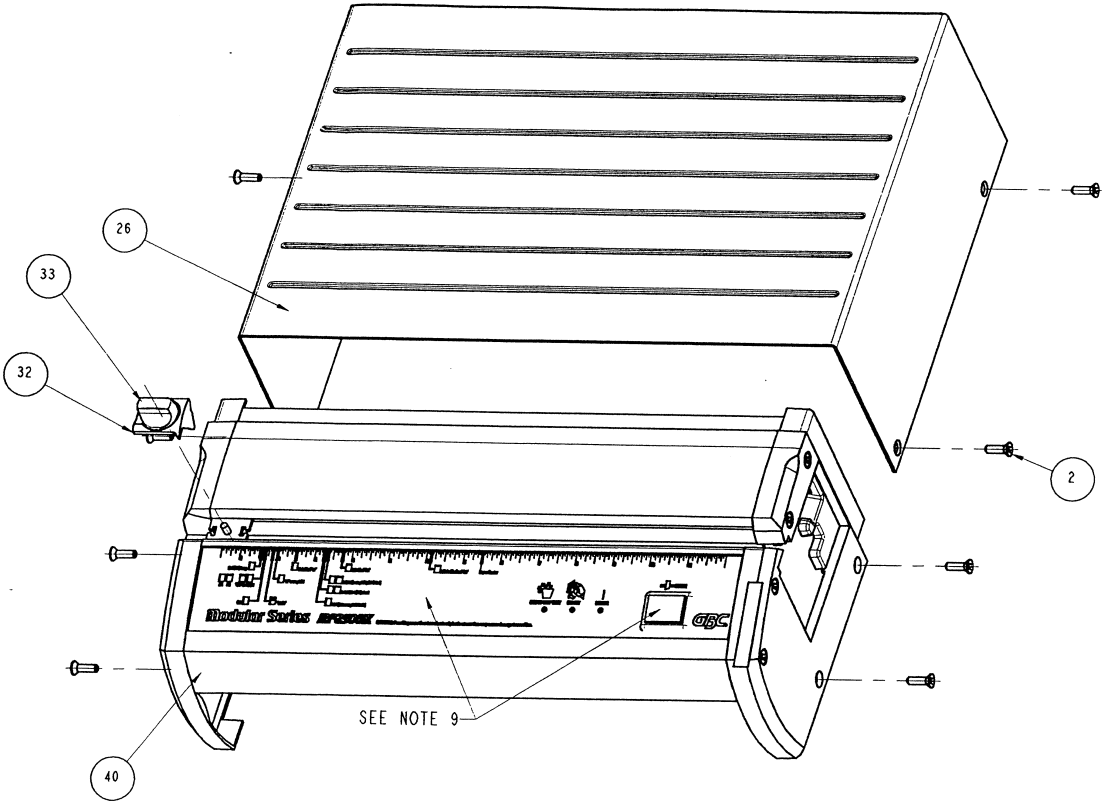

Figure 8-3 - MP2500iX Parts Page 8-5

8.0 PARTS LIST - MP2500iX ELECTRIC PUNCH

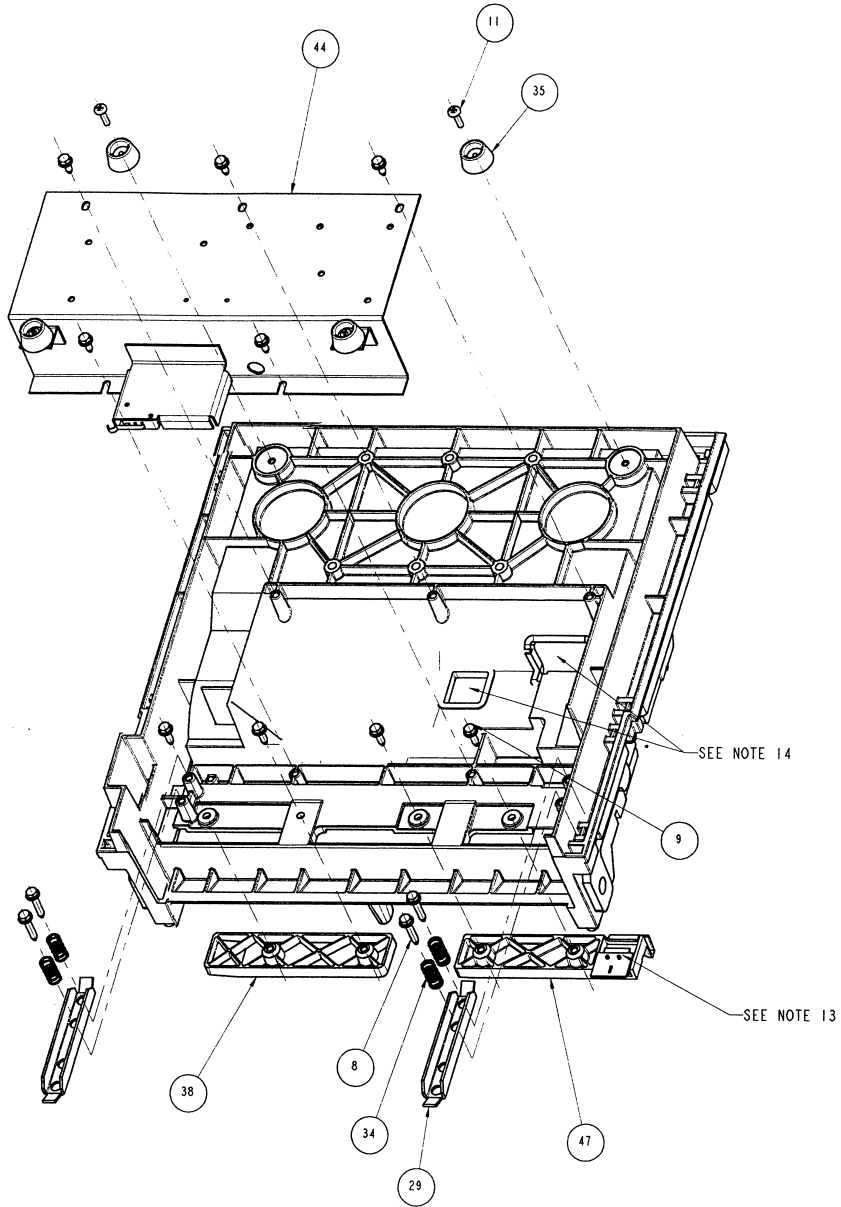

Figure 8-3 - MP2500iX Parts

8.0 PARTS LIST - MP2500iX ELECTRIC PUNCH

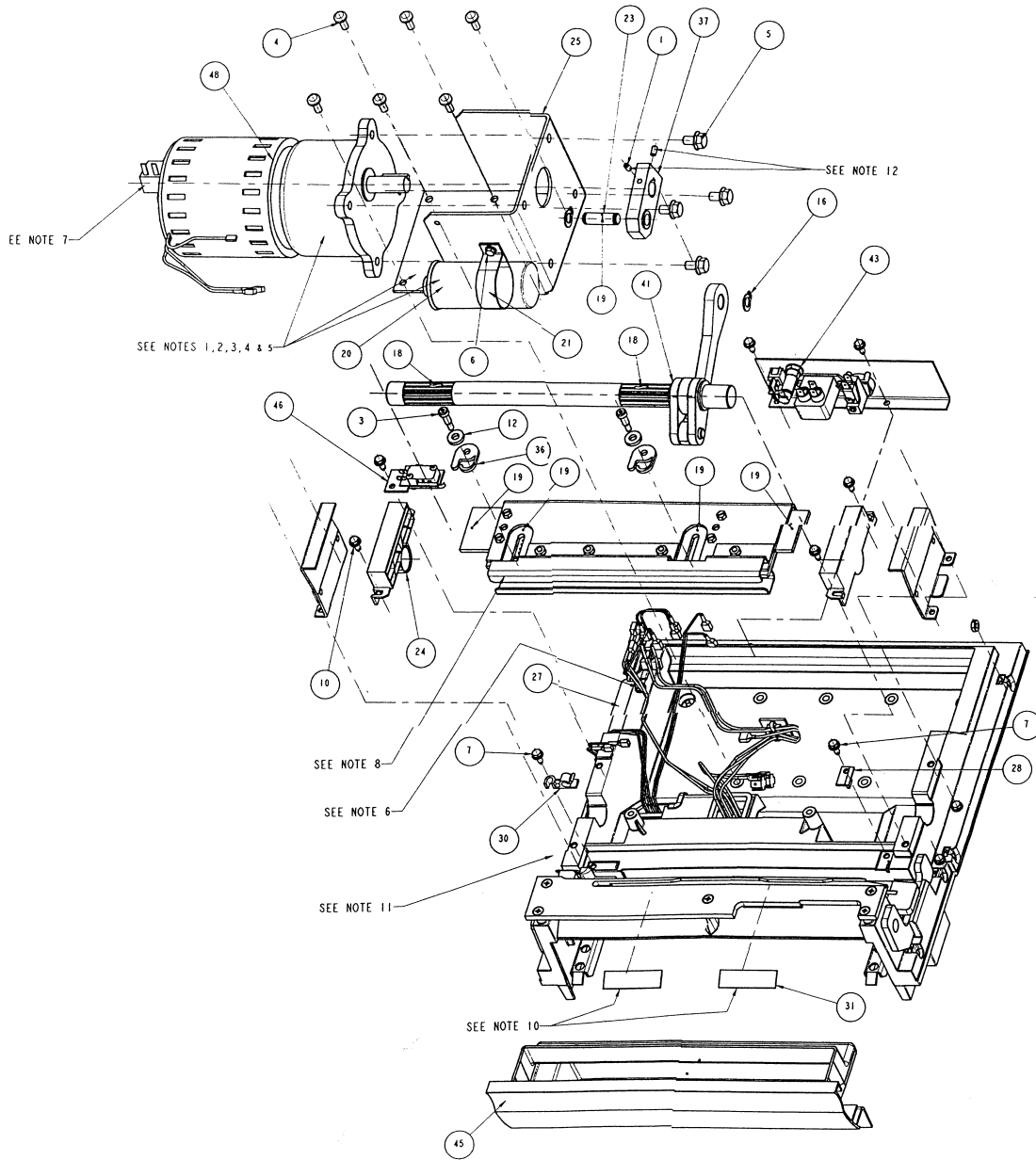

Figure 8-3 - MP2500iX Parts

8.0 PARTS LIST - MP2500iX ELECTRIC PUNCH

1. CAPACITOR AND CAPACITOR BRACKET TO BE INSTALLED PRIOR
 - TO PLACING BRACKET ON BASE.
2. MOTOR BRACKET TO BE INSTALLED BEFORE MOTOR.
3. CLAMP AND TIE WRAP FOOT SWITCH WIRES TO MOTOR MOUNTING BRACKET.
4. INSTALL MOTOR.
5. TIE WRAP INPUT/MOTOR/BRAKE CABLE TO MOTOR WITH 3 TIE WRAPS.
6. SCREW GROUND CABLE TO BASE.
7. BRAKE HUB ASSEMBLY FOR MOTOR 7704442 IS A SERVICE ITEM.
HUB ASSEMBLY PART NUMBER IS 4776308.
8. PRESSURE BAR, SHAFT AND PRESSURE BAR GUIDES CAN BE
PREASSEMBLED OR CAN BE ASSEMBLED IN PLACE.
9. LABEL AND START BUTTON TO BE INSTALLED AFTER EDGE GUIDE
IS ALIGNED IN ASSEMBLY.
10. PLACE DEFLECTORS IN RECESSED AREAS.
11. CABLE CLAMPS NO. 14 AND TIE WRAPS NO. 17 TO BE INSTALLED
ALONG SIDE WALL FOR CABLE ASSEMBLY NO. 55.
12. SET SCREWS TO BE INSTALLED WITH LOCTITE.
13. WIRE SLIDE INTERLOCK SWITCH ASSEMBLY BEFORE ASSEMBLING TO BASE.
14. ACCESS HOLES FOR CABLE ROUTING.

8.0 PARTS LIST - MP2500iX ELECTRIC PUNCH

8.3 Parts Listing

Index	Part Number	Description	Qty
1	1900001	SET SCREW, CUP, 10-32 x 3/8	2
2	1900613	SCREW, 10-32 x 2.25 S.H.C.	8
3	1900827	SHOULDER BOLT	2
4	1951987	SCREW, 1/4 - 20 x 5/8 HX CAP W/NYLOCK	6
5	1903204	SCREW, 5/16-18 x .50 FLANGELOCK	4
6	1907101	SCREW, 10-32 x 11/16 SEMS HX WSH HD TAP SCR	5
7	1907105	SCREW, 10-32 x .50 ST HEX HD	3
8	1907210	SCREW, 10-32 x 1.0 ST HEX HD	4
9	1907215	SCREW, 10-32 x .63 ST HEX HD	4
10	1907807	SCREW, 10-32 x .50 ST HEX HD	11
11	1907843	SCREW, 8-32 x .75 PHIL PH	2
12	1925183	HARDENED WASHER - .281 ID x .63 OD	2
13	1926702	NUT, 10-32 KEPS	8
14	1931047	CABLE CLAMP	4
15	1931250	STRIP, EDGE CORD	1
16	1931612	RETAINING RING	2
17	1932123	TIE WRAP	4
18	1961503	GREASE, LUBRIPLATE #130 AA	2
19	1961531	OIL, GENERAL PURPOSE CITCO	5
20	6205030	CAPACITOR 35UF, 115V	1
20	6205035	CAPACITOR 230V	1
21	6205041	BRACKET, CAPACITOR	1
22	7301052	CABLE, GROUND (PART OF WIRE KIT)	1
23	7704318	PIVOT PIN, CRANK	1
24	7704319	GUIDE	2
25	7704322	MOTOR MTG BRKT	1
26	7704443	HOUSING ASSEMBLY, WITH LABELS - 115V	1
26	7704373	HOUSING ASSEMBLY, WITH LABELS - 230V	1
27	7704329	BASE ASSEMBLY, MACH. & PAINT	1
28	7704331	PAD, ANTI-ROTATION	1
29	7704332	GUIDE, CHIPTRAY	2
30	7704333	DETENT, DIE SET, MOD PUNCH	1
31	7704335	DEFLECTOR, MODULAR PUNCH	2
32	7704339	EDGE GUIDE	1
33	7704340	KNOB, EDGE GUIDE	1
34	7704358	SPRING, CHIPTRAY	4
35	7704368	FOOT, MP2500iX	2

8.0 PARTS LIST - MP2500iX ELECTRIC PUNCH

8.3 Parts Listing

Index	Part Number	Description	Qty
36	7704377	WASHER, PRESSURE BAR, PLASTIC	2
37	7704382	CRANK, 5/8" SHAFT	1
38	7704412	SLIDE, DIE SET, FRONT	1
39	7704414	CHART, FINAL DIESET ASSEMBLY MOD PNC	1
40	7704432	MACHINE FRONT ASSEMBLY	1
41	7704433	LINKAGE ASSEMBLY	1
42	7704434	PRESSURE BAR ASSEMBLY	1
43	7704435	POWER SWITCH ASSEMBLY	1
44	7704436	PCB ASSEMBLY	1
45	7704437	CHIP TRAY ASSEMBLY	1
46	7704438	HOME SWITCH ASSEMBLY	1
47	7704439	SLIDE INTERLOCK SWITCH ASSEMBLY	1
48	7704442	GEAR MOTOR W/SOLE BRAKE – 115V	1
48	6208065	GEAR MOTOR W/SOLE BRAKE – 230V	1
49	7704444	"Z" SUPPORT BRACKET	2
50	7704491	CABLE ASSEMBLY, LINE	2
51	7704492	CABLE ASSEMBLY, NEUTRAL	1
52	7704493	CABLE ASSEMBLY, A.C.	1
53	7704494	CABLE ASSEMBLY, D.C.	1
54	7704496	CABLE ASSEMBLY, TRAY SWITCH	1
55	7704498	CABLE ASSEMBLY, DIESET/FOOT/HOME	1
56	7704499	CABLE ASSEMBLY, INPUT/MOTOR BRAKE	1
57	7704489	WIRE KIT, CABLE ASSEMBLY, ITEM #22, 50-56	1

8.0 PARTS LIST - MP2500iX ELECTRIC PUNCH

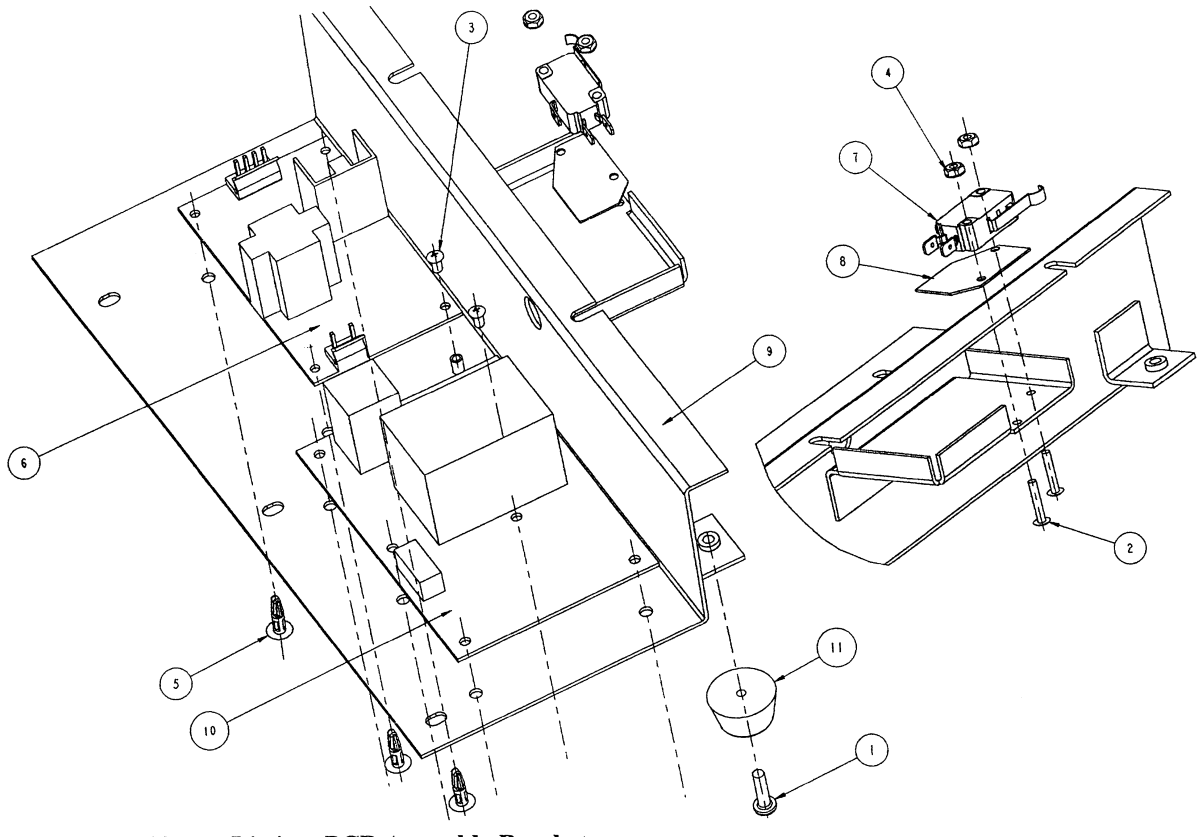

8.4 Parts Listing, PCB Assembly Bracket

Index	Part Number	Description	Qty
1	1902806	SCREW, 8-32 x .63 PHIL PH	2
2	1902834	SCREW, 4-40 x .63 PHIL PH	2
3	1911126	SCREW, 4-40 x .25 PHIL PH, SEMS	2
4	1926804	NUT, 4-40 KEPS	2
5	1951012	P.C.B. SUPPORT	8
6	7301278	POWER SUPPLY	1
7	7301296	SWITCH	1
8	7704334	INSULATOR, CHIPTRAY	1
9	7704353	BRACKET, PCB	1
10	7704355	PC BOARD	1
11	7704368	FOOT, MP2500iX	4

8.0 PARTS LIST - MP2500iX ELECTRIC PUNCH

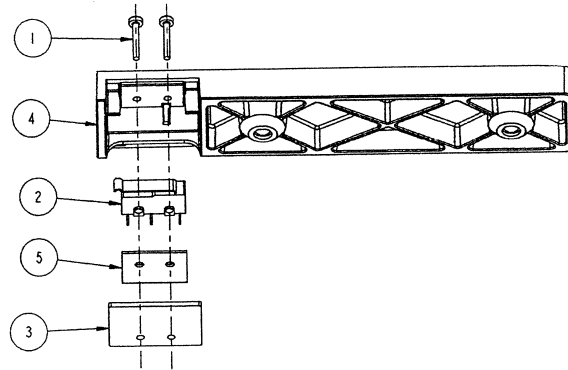

8.5 Parts Listing, Slide Interlock Switch Assembly

Index	Part Number	Description	Qty
1	1902833	SCREW, 2-56 x .5, PHIL PH	2
2	7704326	SNAP SWITCH	1
3	7704328	SWITCH COVER PLATE	1
4	7704357	SLIDE, DIE SET, BACK	1
5	9783651	INSULATOR, SUBMINATURE SWITCH	1

8.0 PARTS LIST - MP2500iX ELECTRIC PUNCH

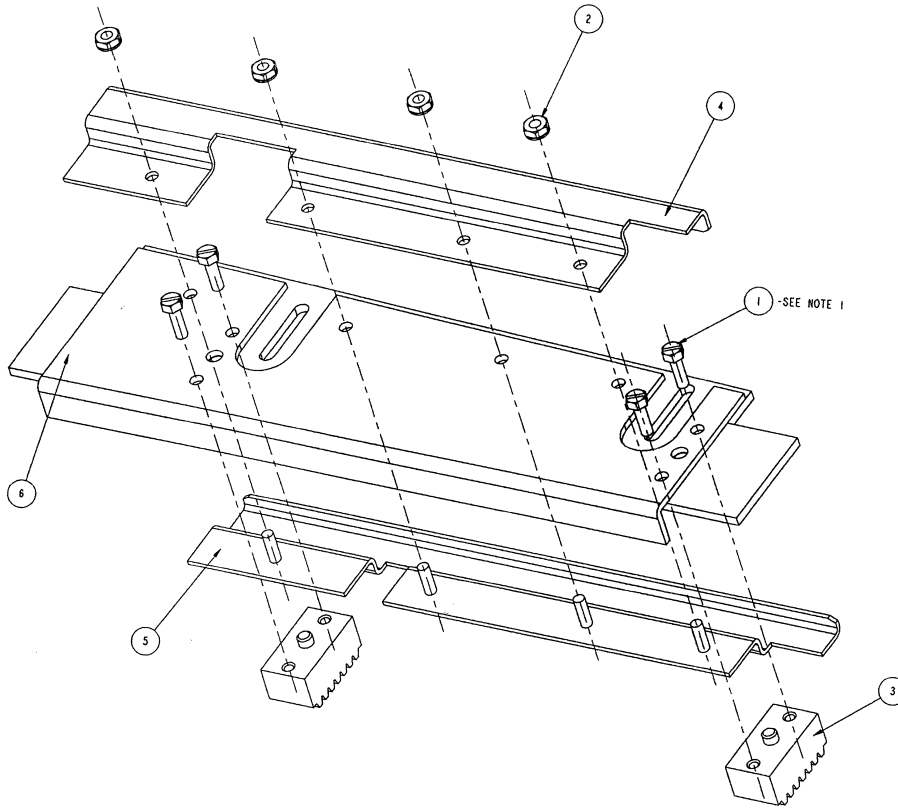

8.6 Parts Listing, Pressure Bar Assembly

Index	Part Number	Description	Qty
1	1907405	SCREW, 10-32 x .63 SLOT HEX HD W/ SEMS	4
2	1926803	NUT, 10-32 KEPS	4
3	7704327	RACK, PRESSURE BAR	2
4	7704343	STRIPPER BRACKET, UPPER	1
5	7704344	STRIPPER BRACKET, LOWER	1
6	7704352	PRESSURE BAR, WELDMENT	1

8.0 PARTS LIST - MP2500iX ELECTRIC PUNCH

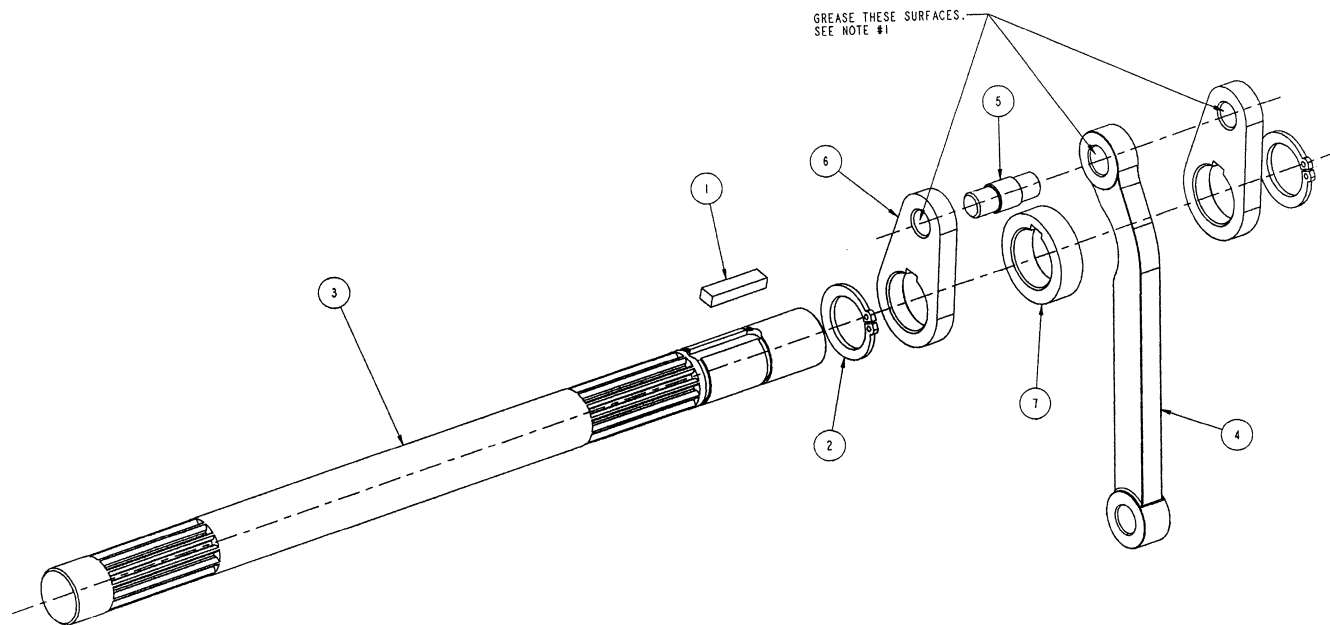

NOTES:

1. APPLY PT. NO. 1961503 (LUBRIPLATE #130-AA)
TO ITEMS #4 & #6 AS SHOWN.
2. ITEM #4 MUST BE FREE TO ROTATE AFTER ASSEMBLY.

Figure 8-7 - MP2500iX Parts, Linkage Assembly

8.0 PARTS LIST - MP2500iX ELECTRIC PUNCH

8.7 Parts Listing, Linkage Assembly

Index	Part Number	Description	Qty
1	1852901	KEY, CONNECTING CRANK	1
2	1931611	RETAINING RING	2
3	7704303	SHAFT, DRIVE	1
4	7704312	CONNECTING LINK	1
5	7704317	PIVOT PIN, SHAFT	1
6	7704350	CONNECTING CRANK	2
7	7704351	SPACER, CONNECTING CRANK	1
8	1961503	LUBRIPLARE #130-AA	.01

8.0 PARTS LIST - MP2500iX ELECTRIC PUNCH

8.8 Die Set Parts Listing (Die Set not shown)

Part Number	Description	Qty
7704445	FELT PAD, OILED	1
7704447	MAGNET, FELT PAD RETAINING	1
7704464	PUNCH PIN, PB	21
7704485	PUNCH PIN, C4	47
7704529	PUNCH PIN, W3 SQUARE	34
7704594	PUNCH PIN, W3 ROUND	34
7704511	PUNCH PIN, W2 SQUARE	23
7704581	PUNCH PIN, W2 ROUND	23
7704543	PUNCH PIN, VELOBIND	12
7704543	PUNCH PIN, SUREBIND	10
7704568	PUNCH PIN, LOOSE LEAF, 2-4 / 3-5-7	11

Die Set repair is not recommended other than to clean and lubricate the Punch Pins. Punch pins are listed here as a service item only in the event that some may be lost.

If a Die Set produces poor hole quality over time, it is more likely a result of Die Plate wear. In this case the Die Set should be replaced with a new one.

8.8 Complete Die Set Assemblies including shipping carton

Part Number	Description
7704450	DIE SET, PB
7704490	DIE SET, C4 GBC
7704590	DIE SET, W3 ROUND
7704520	DIE SET, W3 RECTANGULAR
7704470	DIE SET, W2 ROUND
7704500	DIE SET, W2 RECTANGULAR
7704570	DIE SET, LOOSE LEAF 3-5-7/2-4
7704560	DIE SET, SB
7704550	DIE SET, VB