

Luxor AVJ42 Adjustable Height Black Steel 3- Shelf A/V Cart

Instruction Manual



Provided by

MyBinding.com
When Image Matters.

Call Us at 1-800-944-4573

LUXOR

INNOVATIVE WORKSPACE PRODUCT SOLUTIONS

Adjustable Height Metal Cart Instructions

Parts List

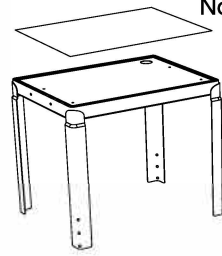

A x1

Non-slip mat

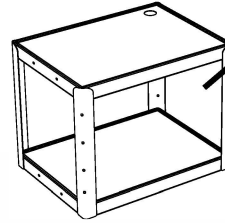

B x1

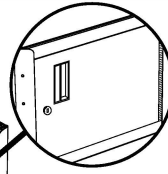

Cabinet comes pre-assembled on units that include a cabinet.

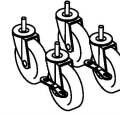

C x4

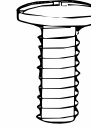

D x4



E x4

Tools Required

- Phillips Screwdriver
- Rubber Mallet
- Pliers or Adjustable Wrench

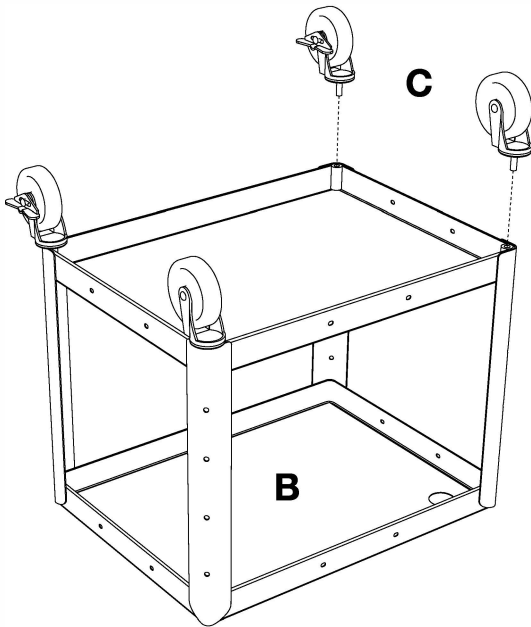

1

Position the bottom shelf **B** so that the caster holes are facing up. Insert caster **C** into the caster holes on the bottom of shelf **B**. Use a mallet to set the casters properly.

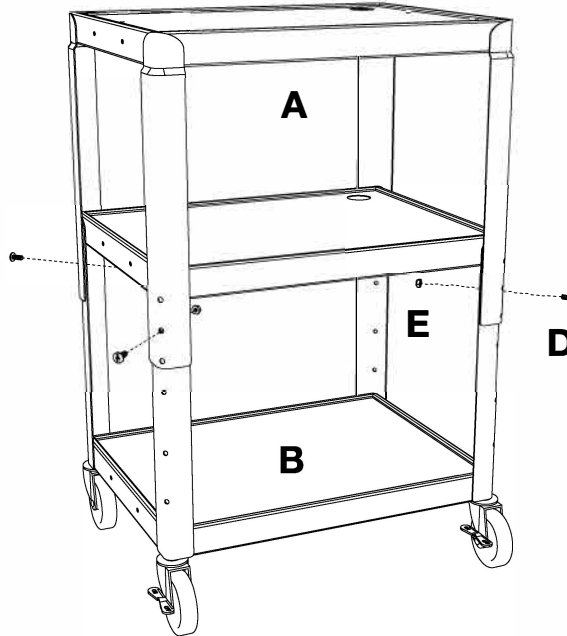

2

Flip bottom shelf **B** so that it is on its side. Set top shelf **A** so that it overlaps bottom shelf **B**. Align the screw holes so that the top shelf **A** is at the desired height.

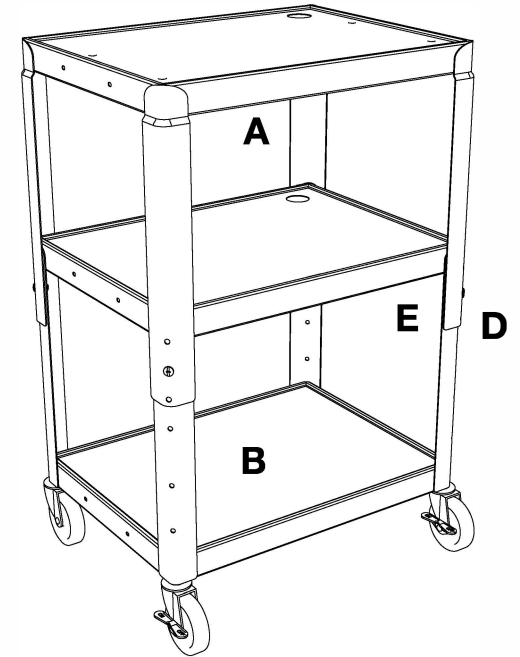

3

Insert screw **D** through the aligned screw hole of **A** and **B** and fasten nut **E** with pliers and screwdriver. Place Non-slip mat on desired shelf. The cart is now complete.

Parts List

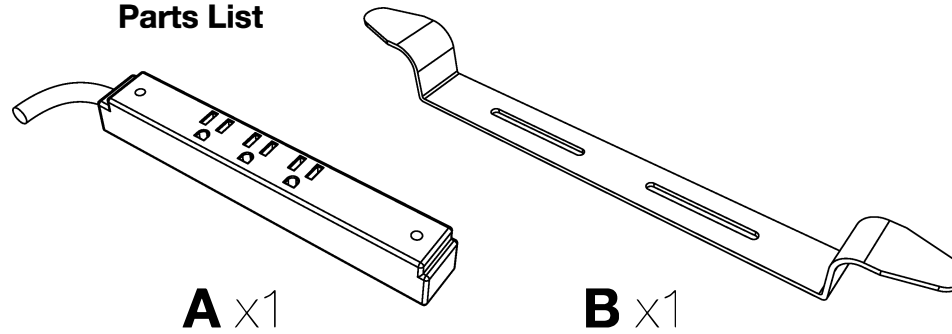

Tools Required

- Screwdriver

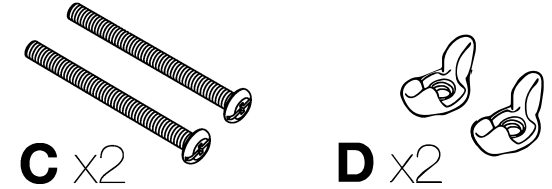

Electric Assembly Instructions

Number of outlets may vary.

Call Us at
1-800-944-4573
for Orders or Inquiries

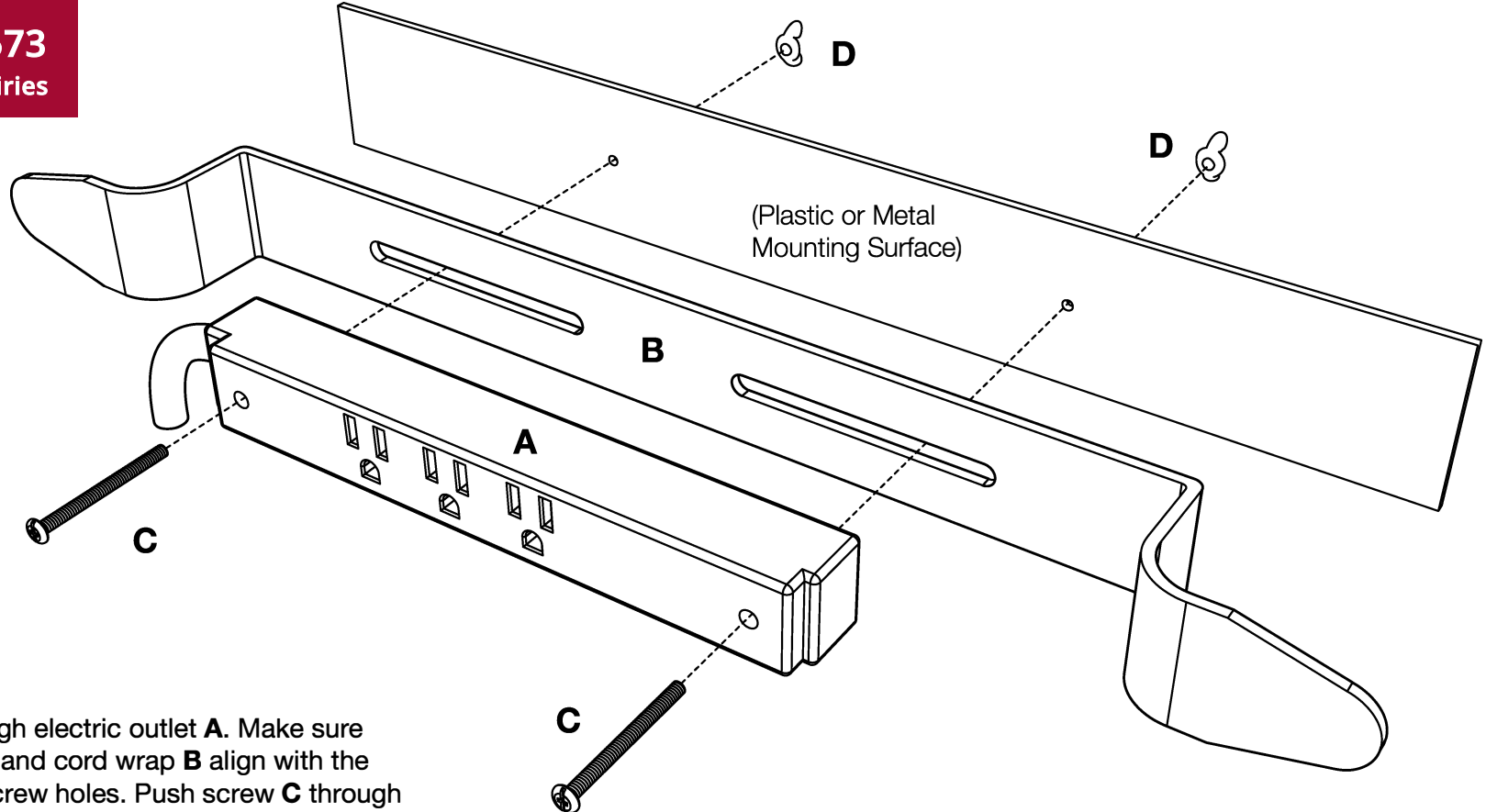

1

Push screw **C** through electric outlet **A**. Make sure the electric outlet **A** and cord wrap **B** align with the mounting surface screw holes. Push screw **C** through cord wrap **B** and the mounting surface screw holes. Use wing nut **D** and screwdriver to fasten.