

***Luxor LE48C-B 48.25" High  
Black 3-Shelf Endura A/V  
Utility Cart with Cabinet***

Instruction Manual



*Provided by*

**MyBinding.com**  
*When Image Matters.*

Call Us at 1-800-944-4573

### Parts List

### Tools Required

- Rubber Mallet

#### NOTICE:

Leg lengths of leg **E** may be shorter than leg **F**

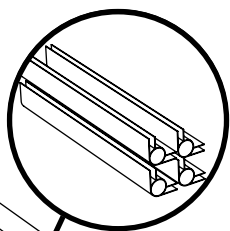

Optional fluted legs for units with cabinet pack

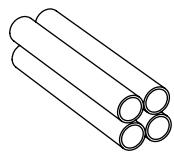

**E** x4

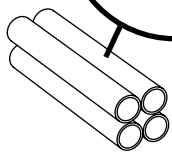

**F** x4

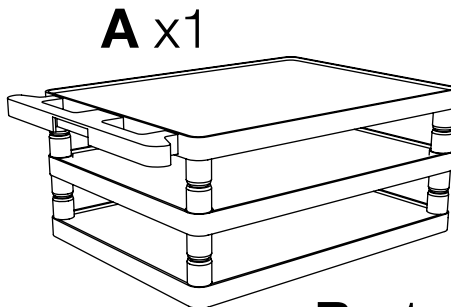

**A** x1

**B** x1

**C** x1

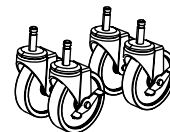

**D** x4

**1**

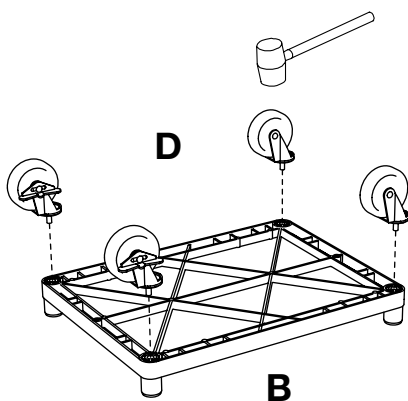

**2**

Install optional cabinet pack / pullout shelf / electrical assembly after step 1

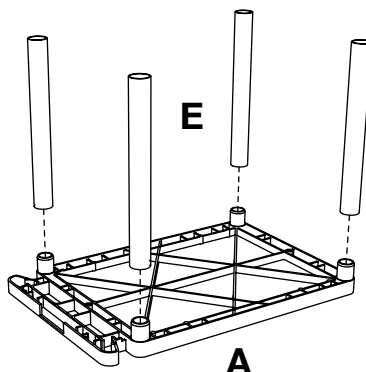

**3**

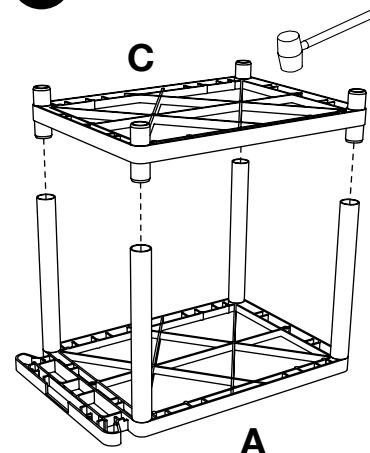

**4**

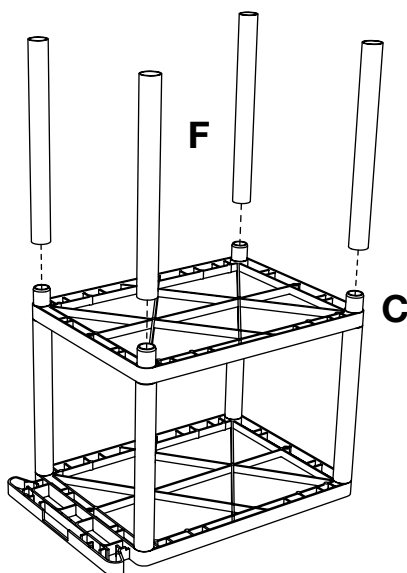

**5**

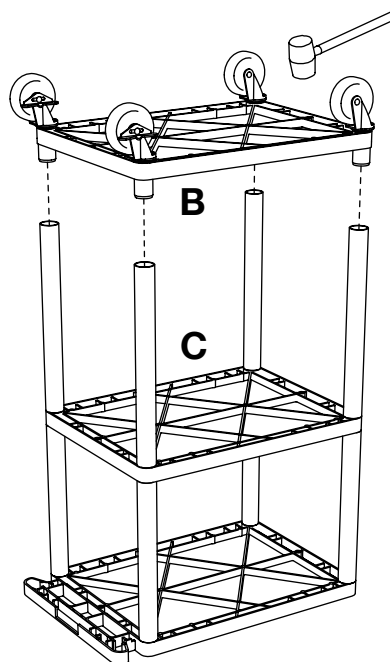

**6**

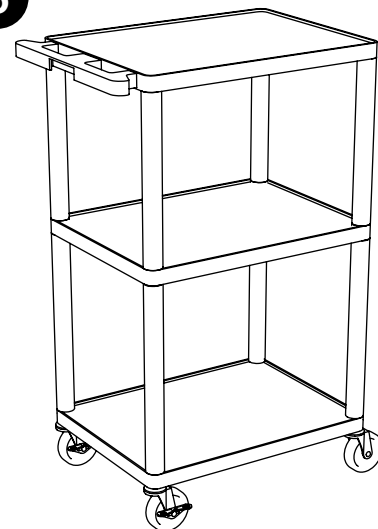

## Parts List

## Tools Required

- Rubber Mallet

## Plastic Cart Cabinet Pack Instructions

Please consult your cart base unit instructions before starting

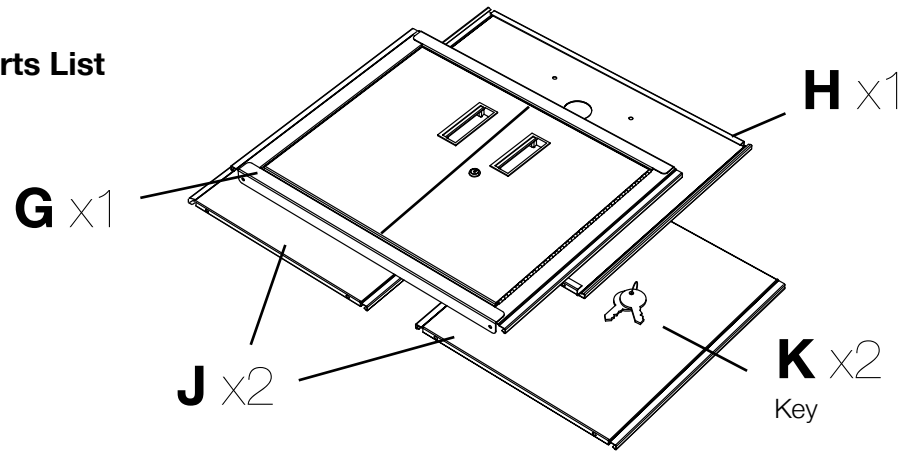

1

**IMPORTANT:** Flip shelf **B**, and lock the 2 locking casters **D** before assembling the unit.

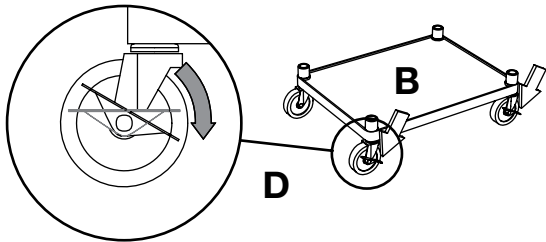

2

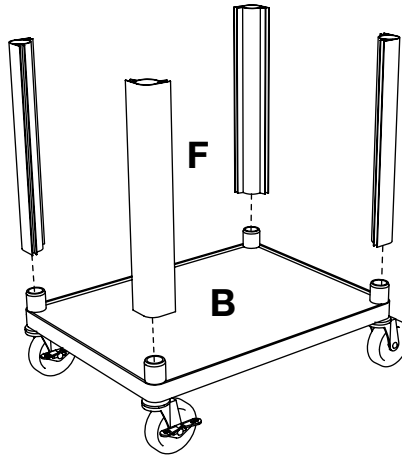

3

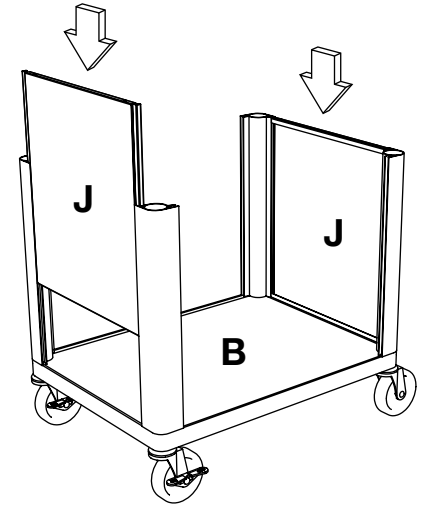

4

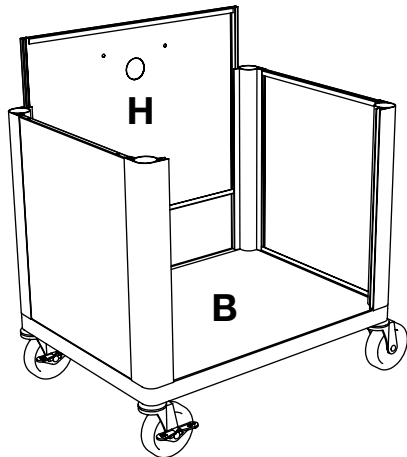

5

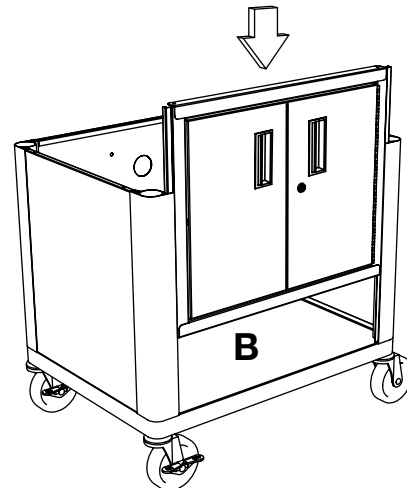

6

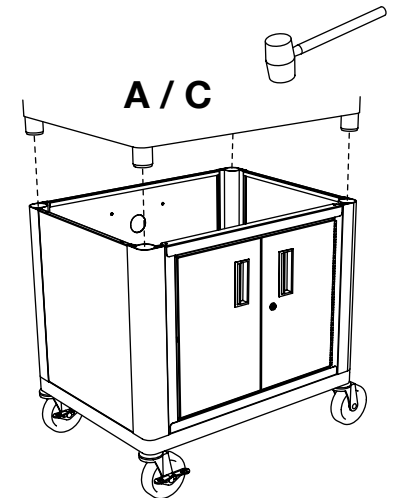

## LP + LE Electrical Assembly Instructions

### Parts List

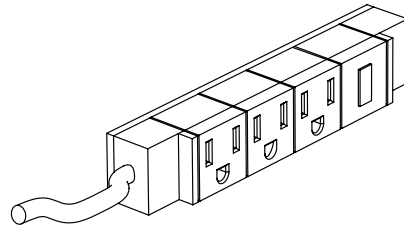

**F** x1

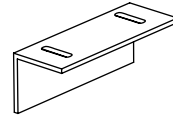

**G** x1

### Tools Required

- Philips Screwdriver

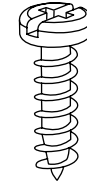

**H** x3

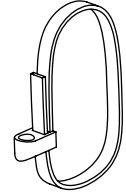

**J** x1

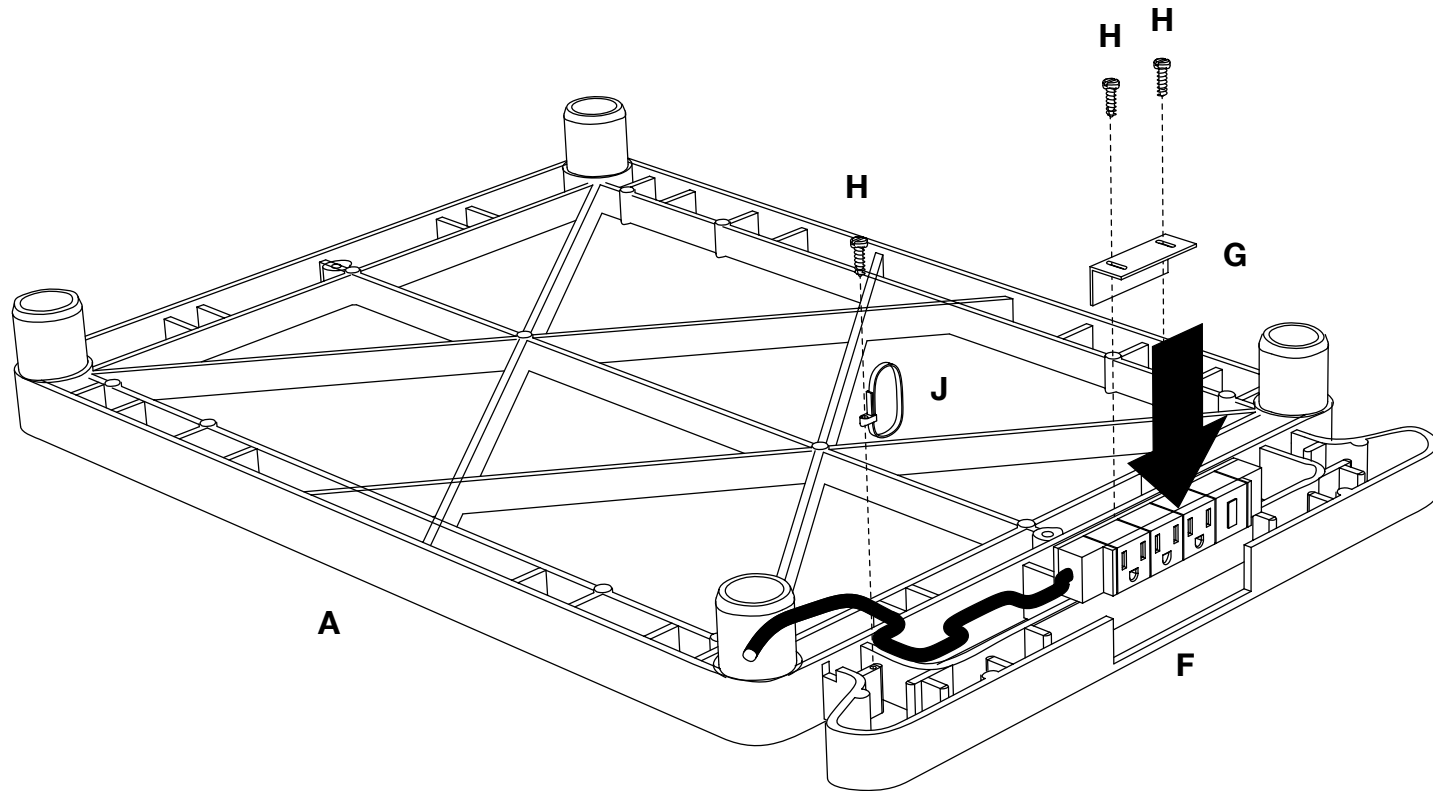

**1**

Attach electric outlet **F** to top shelf **A**, secure with L bracket **G** and cable lock **J**. Loop outlet cable **F** through cable lock **J** and the inserts on shelf **A**. Screw L bracket **G** and cable lock **J** onto top shelf **A** with screw **H** and a philips screwdriver.

Call Us at  
**1-800-944-4573**  
for Orders or Inquiries