

Luxor Endura 26" High Black 2-Shelf A/V Utility Cart with Cabinet

Instruction Manual



Provided by

MyBinding.com

When Image Matters.

Call Us at 1-800-944-4573

Parts List

Tools Required

- Rubber Mallet

NOTICE:
Leg lengths may vary by model

A x1

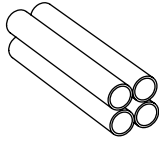

F x4

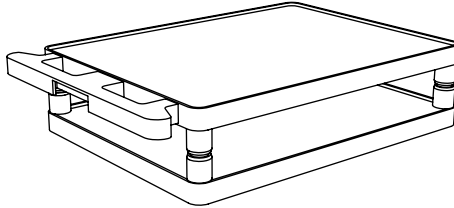

B x1

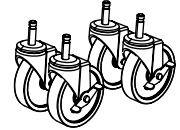

D x4

1

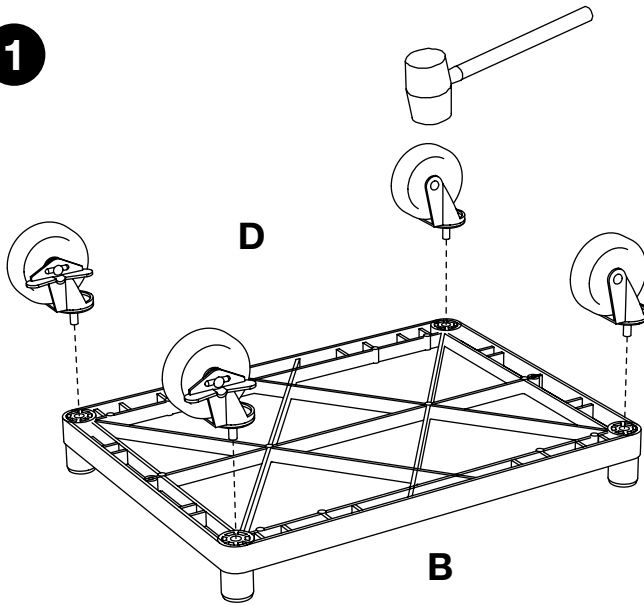

2

Install optional cabinet pack / pullout shelf / electrical assembly after step 1

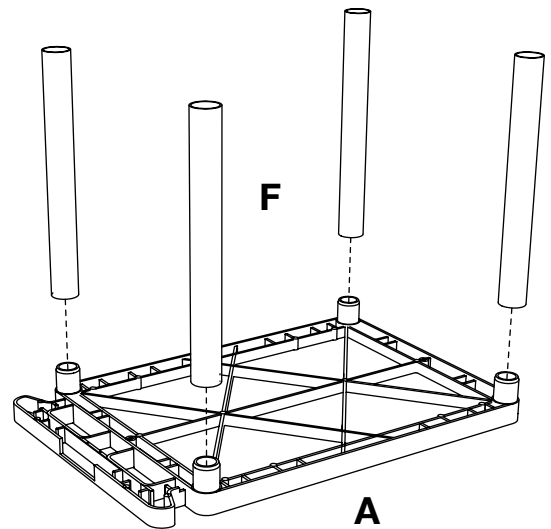

3

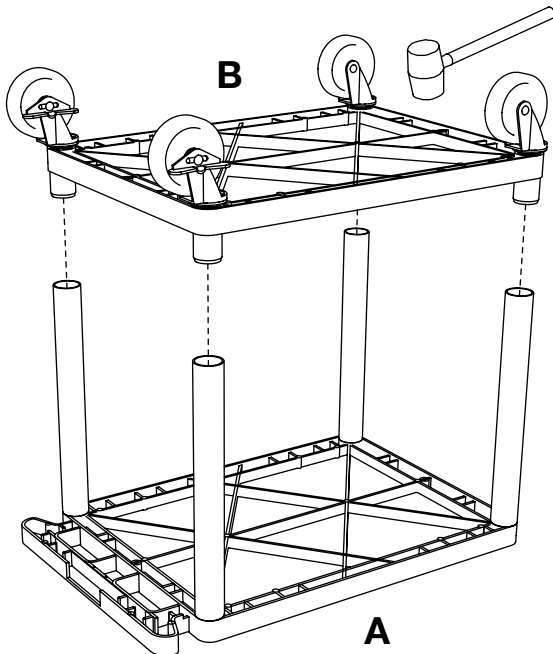

4

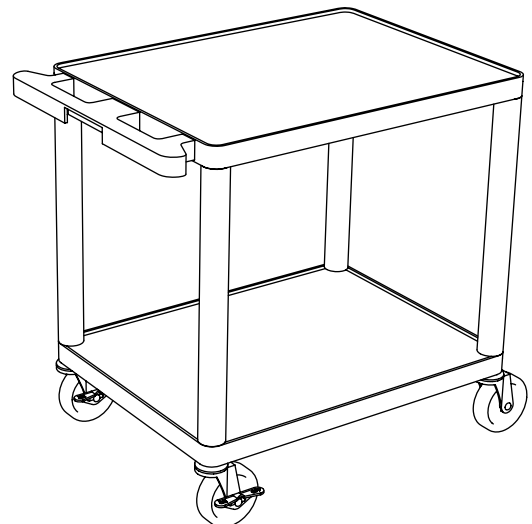

Plastic Cart Cabinet

Pack Instructions

Round Legs

Please consult your cart base unit instructions before starting

Parts List

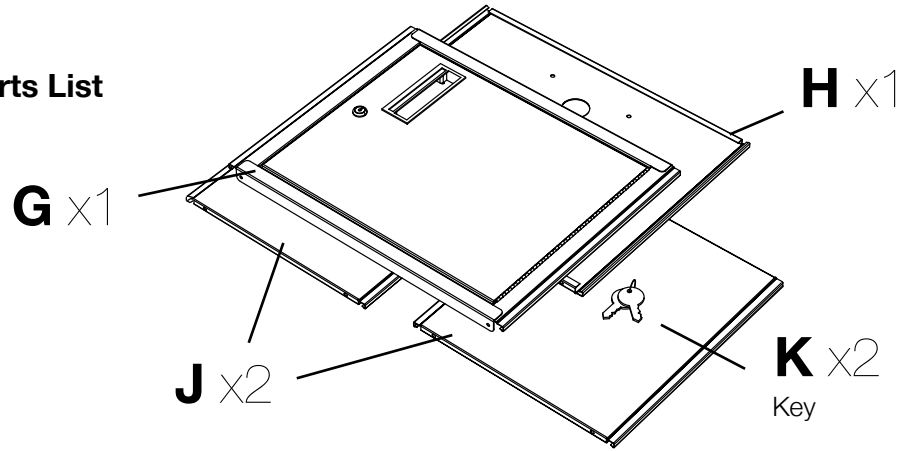

Tools Required

- Rubber Mallet

1

IMPORTANT: Flip shelf **B**, and lock the 2 locking casters **D** before assembling the unit.

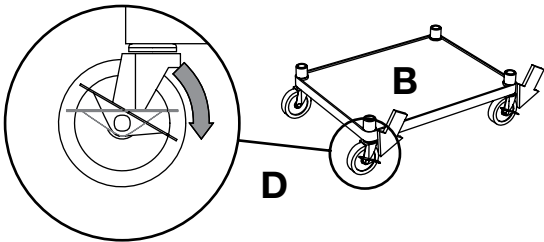

2

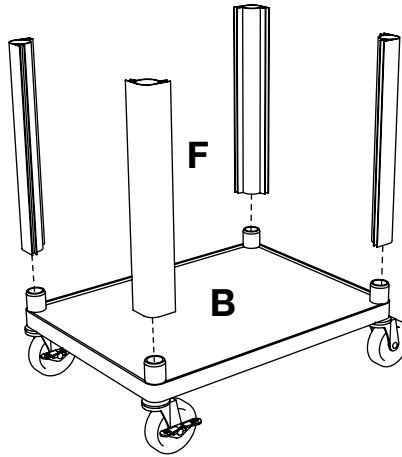

3

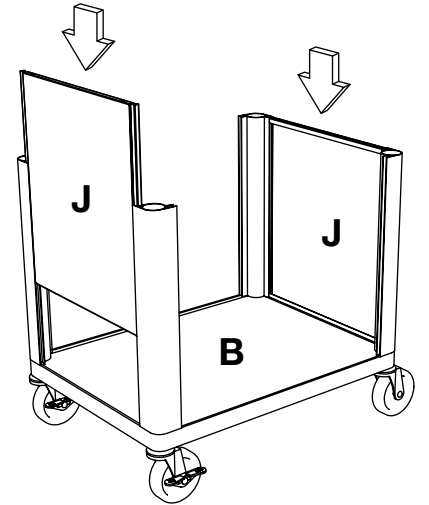

4

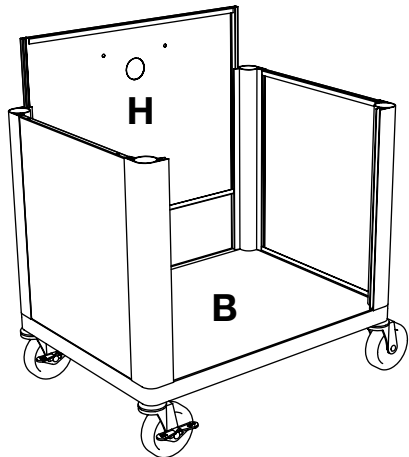

5

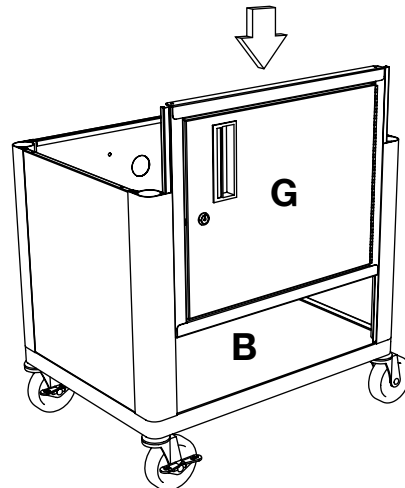

6

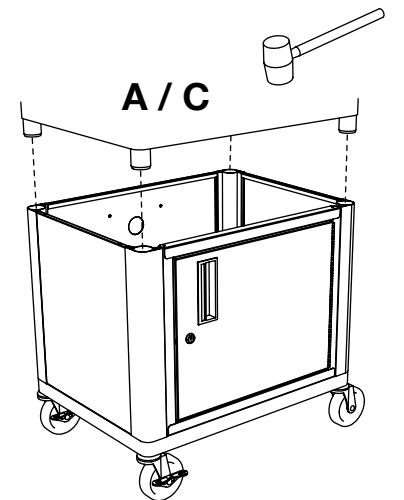

LP + LE Electrical Assembly Instructions

Parts List

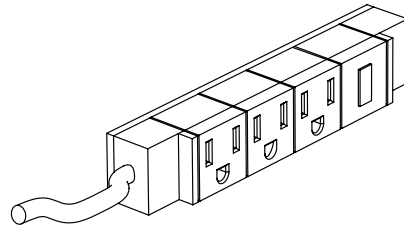

F x1

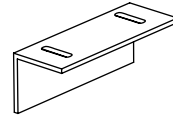

G x1

Tools Required

- Philips Screwdriver

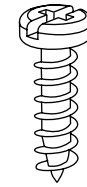

H x3

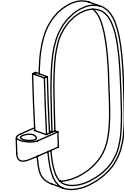

J x1

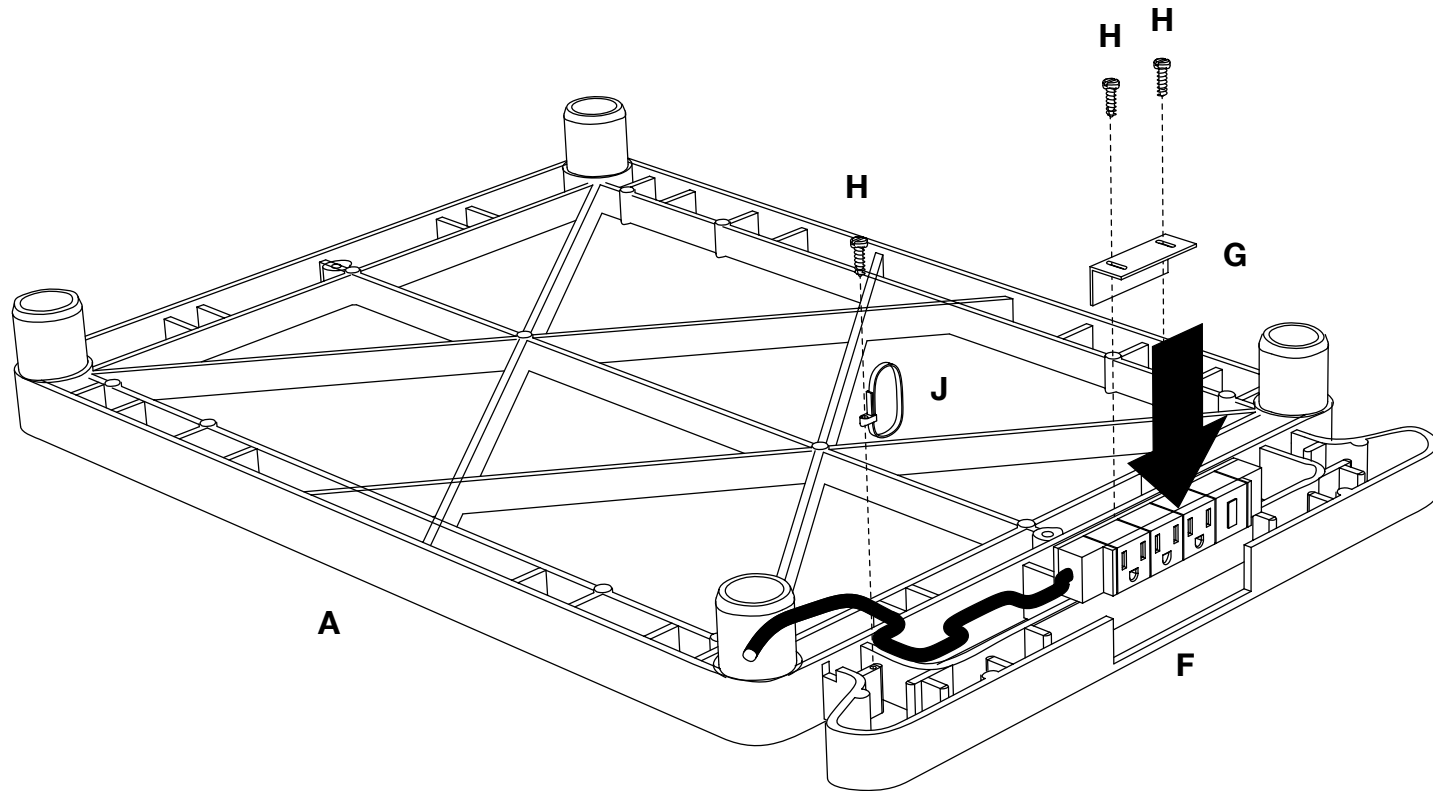

1

Attach electric outlet **F** to top shelf **A**, secure with L bracket **G** and cable lock **J**. Loop outlet cable **F** through cable lock **J** and the inserts on shelf **A**. Screw L bracket **G** and cable lock **J** onto top shelf **A** with screw **H** and a philips screwdriver.

Call Us at
1-800-944-4573
for Orders or Inquiries