

Martin Yale 1632 Automatic Letter Opener

Instruction Manual



Provided By

MyBinding.com®
When Image Matters.

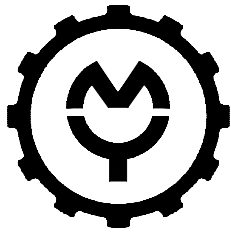

MARTIN YALE

Industries

MODEL 1632

AUTOMATIC LETTER OPENER

INTRODUCTION

Thank you for selecting the Martin Yale Model 1632 Letter Opener. This letter opener was designed for easy installation, set-up, and operation with minimal maintenance required. We recommend that you familiarize yourself with the Martin Yale 1632 Letter Opener by carefully reading this manual. Thorough understanding of this information will eliminate most operator-associated errors.

WARNING! Never connect power to the machine until you are ready to set up and operate the letter opener. During set up, operation, and maintenance keep hands, hair, loose clothing, and jewelry away from all moving parts. Serious bodily injury could result. Service, or disassembly of letter opener should only be attempted with the power disconnected and locked out.

SPECIFICATIONS

Power: 115 V.A.C., 50 or 60 Hz.	Speed: 7,000/hr. (#10 Envelope)
Dimensions: L-13 ¾" x W-10 ¼" x H-5 ½"	Load Capacity: 1 ¾" Stack Height
Max. Envelope Size: 4 1/8" x 9 ½" (#10)	Weight: 6.3 Lbs.

1.0 Features

- * The Martin Yale 1632 Letter Opener quickly and efficiently feeds and opens the most commonly used envelope sizes (#6¾, #8, #9, & #10).
- * Easy to assemble, set-up, and operate
- * Low maintenance

2.0 Parts

1. Power Cord
2. Conveyor Belts
3. Holdback Assembly
4. Bottom Blade
5. Top Blade
6. Feed Deck
7. Top Housing
8. Bottom Housing
9. Chassis
10. Blade Cover

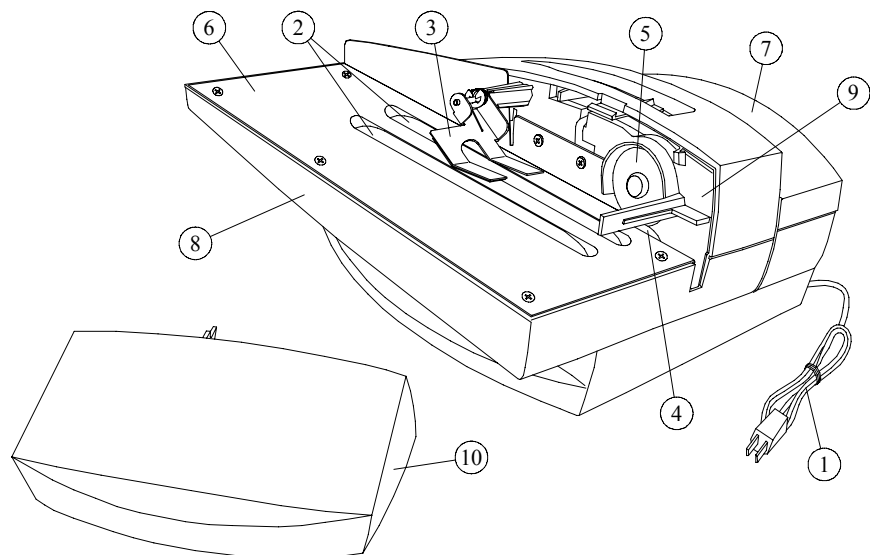

3.0 Installation

3.1 Unpacking

Carefully unpack the letter opener. The rubber feet are in a separate bag. Place all of the packing material back in the shipping box and store the box for any future shipment of the letter opener. Inspect the letter opener and all accessories for shipping damage. If any damage is found, contact the carrier immediately.

3.2 Assembly

Make sure the machine is **OFF** as denoted by the 'O' symbol on the power switch. Plug the power cord into a 115 Volt, 50-60 Hz outlet. The letter opener is now ready to be put into use. Place the letter opener on a flat, level surface where it will be used. It is necessary to have a clear area next to the letter opener for the opened letters and scrap to fall.

***Note:** The letter opener sits at an angle. This is normal.

3.3 Catch Tray Assembly

Carefully unpack the catch tray and catch tray pin. Unfold the catch tray and lay flat on a table (see below). Fold both sides up and install the catch tray pin in the indicated place (see illustration).

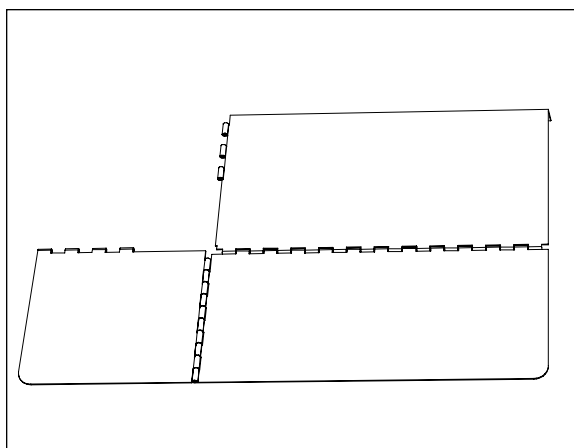

Catch Tray Before Assembly

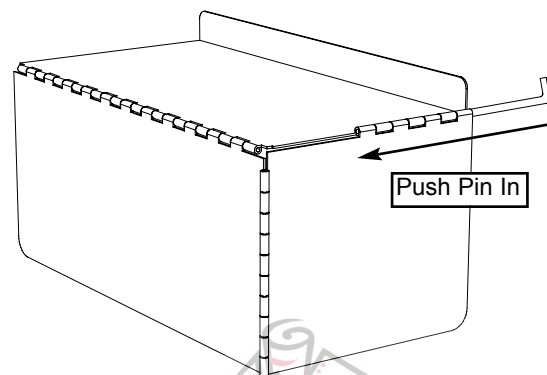

Aligning Hinge and Installing Pin

4.0 Operation

4.1 Preparing Envelopes

Sharply tap the stack of envelopes to be opened against the tabletop or other hard object. This will settle the contents to one side, allowing the opposite side to be opened without cutting into the contents.

4.2 Loading Envelopes

With the letter opener **OFF**, place the stack of envelopes on the feed deck with the side to be opened flat against the back side of the deck and the leading edge of envelopes against or even with blade cover (see photo at right). **NOTE:** Do not push any portion of the stack underneath the blade cover.



HINT: You may find the letter opener feeds more smoothly if the letters are fanned (see photo at left). Also, some types of envelopes may open easier on the bottom edge rather than the top (with the sealed flaps facing up, away from the conveyor belts).

4.3 Opening Envelopes

Turn the letter opener **ON** by pressing the 'I' side of the OFF/ON switch. The envelopes will start feeding and opening. Turn **OFF** the letter opener when the stack of envelopes have been opened by releasing the OFF/ON switch. Repeat this process for each stack of envelopes; do not attempt to add stacks of envelopes with the machine running. Do not run the machine without envelopes in it as premature wear on the conveyor belts and hold back wheels will result. **NOTE: The feed belt bounces up and down during use to facilitate paper feeding. This is normal.**

5.0 Maintenance

5.1 Conveyor belts

When the letter feed becomes erratic, cleaning will be necessary to remove the coated ink, toner, lint and other contaminants. Simply clean the feed belts with a cloth and Martin Yale Roller Cleaner and Rejuvenator. Replace the feed belts when they will no longer feed after cleaning.

5.2 Scrap Removal

Smooth functioning of the Martin Yale 1632 Letter Opener may require cleaning out any accumulated scrap. Pay particular attention to the blade area. Strips of paper may wind up behind the blades and cause trouble. Removing the deck to clean the interior may be necessary. Call Martin Yale Customer Service at (260) 563-0641 for details. Plastic and painted surfaces may be cleaned with a clean cloth dampened with water and/or a mild household cleanser.

6.0 Operator's Troubleshooting Guide

6.1 Envelopes jam in blade and do not exit letter opener.

Paper jamming in letter opener blades is most often caused by scrap paper interfering with the cutting blades. Use the following steps to clear a jam:

1. Disconnect the power cord.
2. Remove blade cover by inserting a coin in the notch on top and prying it off.
3. Use the end of ballpoint pen or other similar object to gently clear the paper from the blade area. **Caution: Be very careful, as the blades are very sharp.**
4. When finished, replace blade cover and run machine without envelopes. Ensure that both blades are spinning.

6.2 Envelopes fail to feed, machine runs

Failure to feed envelopes can be caused by several different reasons; they are listed in declining order of likelihood:

1. Dirty conveyor belts. Clean with Martin Yale Rubber Roller Cleaner and Rejuvenator.
2. Envelopes are too wide to feed. Review maximum envelope sizes listed on the front cover of these instructions.
3. Envelope is too thick. The Martin Yale 1632 Letter Opener was designed to open typical letter and business style envelopes (up to 3/16" thick).
4. Conveyor belts are worn beyond use. Call Martin Yale Customer Service at (260)-563-0641.

6.3 Envelopes feed more than one into the cutting blades

1. Holdback spring is weak or loose. Check to see if spring is in place. If so, it can be easily removed and bent to exert more pressure on the Holdback assembly.

6.4 Machine does not run at all

1. Check that the power cord is plugged into an active line.
2. Self-resetting breaker has tripped. The motor is protected by a built-in thermal breaker. When the motor cools sufficiently, this self-resetting breaker will automatically reset and the letter opener will start running again.
3. Electrical Malfunction. Call Martin Yale Customer Service at (260)-563-0641.
4. The motor drive belt has failed. Call Martin Yale Customer Service at (260)-563-0641.



251 Wedcor Ave. Wabash, IN 46992
Phone: (260) 563-0641 Fax: (260) 563-4575
Website: www.martinyale.com Email: info@martinyale.com