

TABLETOP BUSINESS CARD SLITTER QUICK INSTRUCTIONS

I. Set up from carton to table

- A. Unpack Business card splitter and accessories, place business card splitter on a stable level surface near an electrical outlet.
- B. Untape machine accessories and place aside.
- C. Install paper support as shown in Figure #1 and Figure #2.
- D. Install catch trays. Line up tabs and slots as shown in Figure #3. Let trays hang from splitter. Longer tray goes on lowest level, shorter tray goes on level above. Install Bottom tray first. See Figure #4. **NOTE: On the 410 and 412 Business Card Slitters, the bottom stacking tray and paper support must be moved to the top shelf to utilize the scoring and perforating functions.**

Install
Paper
Support

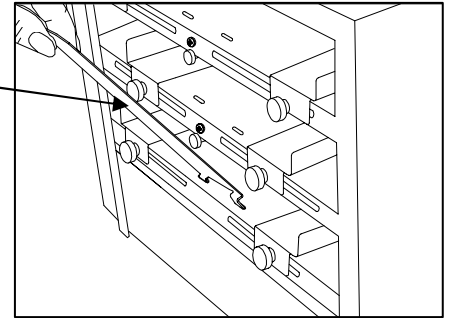

Figure #1

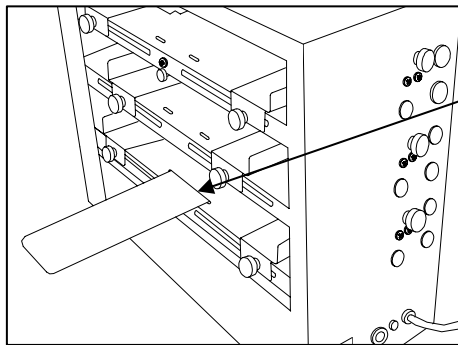

Figure #2

Let Paper Support rest on feed shelves
after inserting tabs

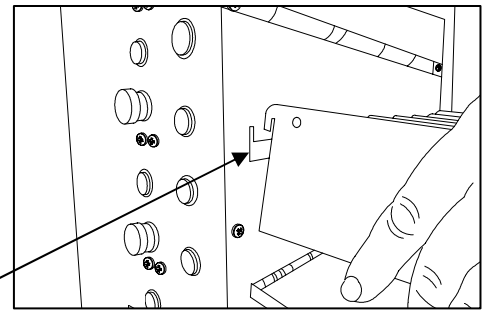

Figure #3

Line tabs of exit trays
up with slots on machine
and "hang" exit trays from splitter

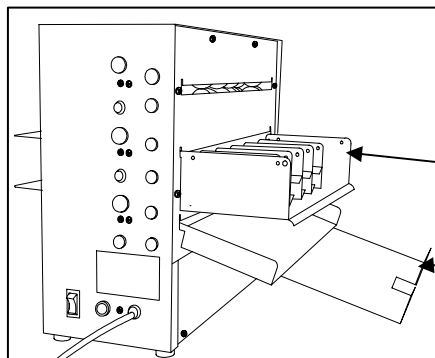

Figure #4

Install short tray on level above

Install longer exit tray on bottom

II. Set-up

A. Paper guide set up. Not all paper widths are necessarily equal from ream to ream and paper guide adjustment may be needed for each size. To adjust paper guides, follow the steps below:

1. Turn splitter off and unplug.
2. Slide a single sheet of stock into the appropriate feed shelf. First pass (3 ½" cut) goes on lower shelf; second pass (2" cut) goes on the shelf above. Registration marks on stock must be face up.
3. Push stock all the way in to the blades.
4. Check location of registration marks to blades. If they do not align, loosen both and move the paper guides with stock left or right until the registration marks (see Figure #6) align themselves with the cutter blades. You may need a flashlight to see the cutter blades from the feed side. Tighten paper guides down so that side-to-side movement of stock is no more than 1/64". Paper guides too tight will result in inconsistent feeding; too loose will result in skewing.

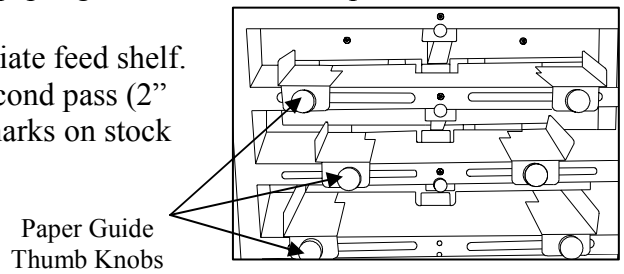

Figure #5

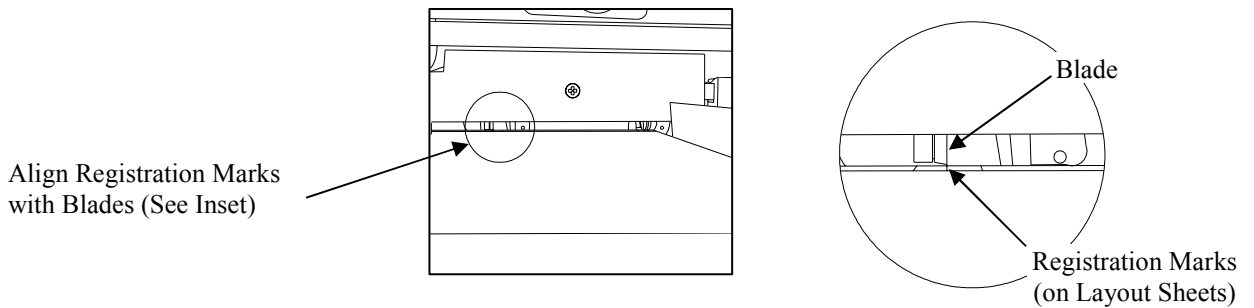

Figure #6

B. Retarder set-up. See Figure #7 for picture of retarder location. Retarder is raised or lowered by turning the retarder adjustment knob as shown in Figure #8. Proceed as listed below.

1. Turn off and unplug machine.
2. Turn all retarder adjustment knobs 1 turn counter clockwise; you should see the paper retarder rise slightly. **Do not turn retarder knob more than 1 turn counter-clockwise.**
3. Place a piece of stock between retarder and feed wheel. Slowly turn the appropriate retarder adjustment knob clockwise until a distinct drag is felt on the feed tire while the stock is moved in and out. Fine tuning of the retarder can be accomplished by slightly turning the retarder knob while the splitter is running with stock in it. **Note: Retarder should not touch feed roller.**

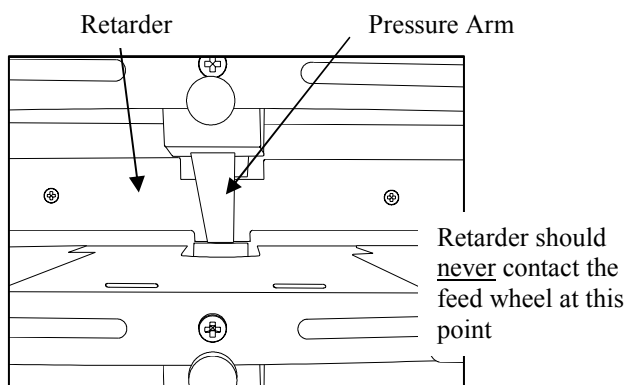

Figure #7

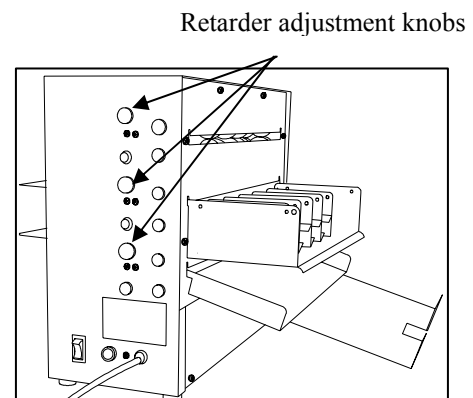

Figure #8

C. Pressure Arm adjustment. See Figure #9 for pressure arm location and pressure arm adjustment Knob. For 65# and heavier stock the pressure arm typically does not need adjusted from the factory location. If adjustment is needed for lighter stock proceed as listed below:

1. Turn off and unplug machine.
2. Turn pressure arm adjustment knob clockwise to lower pressure arm and counter-clockwise to raise pressure arm. **NOTE: Very little turning of the pressure arm adjustment knob is needed to result in a substantial change in pressure arm location.** Typically only a slight turning of the pressure adjustment knob is needed to adjust the machine to the desired point.
3. Turn knob so that the pressure arm slightly drags a single piece of stock, but does not touch the feed wheel. See Figure #10. **NOTE: If the pressure arm drags on the feed wheel, feed wheel damage will occur (if extended operation without stock in place).**

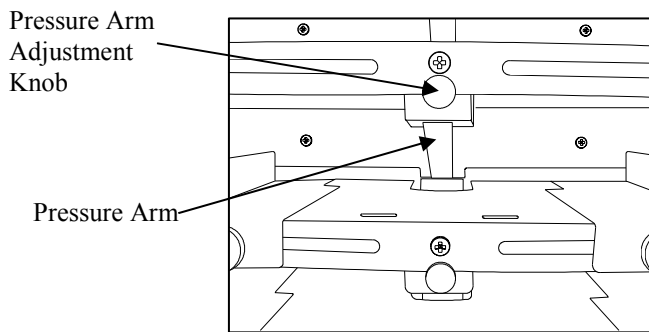

Figure #9

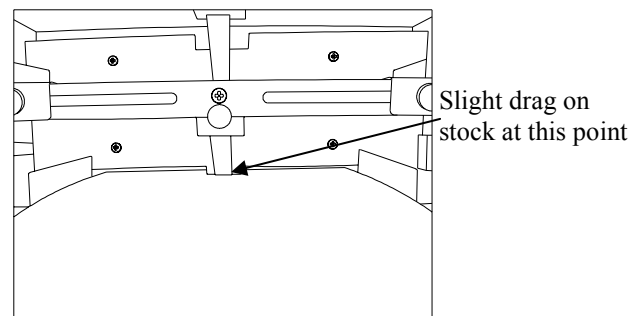

Figure #10

III. Pre-use checks

A. Plug Slitter into a 115 V.A.C. outlet and turn it on (without stock). The machine should immediately begin to run. If slitter stalls for more than 5 seconds, check for:

1. Dead electrical outlet
2. Obstruction in blades
3. Tripped breaker, find source of machine bind and correct. Push in breaker to reset.

Warning: These units contain rotating blades and other dangerous items. Do not remove any safety covers from the machine. Beware that loose jewelry, long hair and loose fitting clothes should be kept away from the unit at all times.

B. Run machine for a couple of minutes without stock to seat the blades.

IV. Running

A. Now that the slitter is set up, card stock can start to be run through it. Follow the steps as listed below. Please note that slitting business cards requires 2 passes through the machine. The 1st pass is done on the lowermost level, the product of that level is then placed on the level above where the business cards are cut to their final 3 1/2" X 2" size.

1. Put a single sheet in the lowest shelf and turn machine 'ON'. It should feed and slit. See Figure #11. **NOTE: You may see oil residue on the first few pieces of stock. This is normal. Use unprinted stock to remove.**
2. If stock goes as far as the blades and then stops, the retarder is slightly too wide. Slowly turn retarder knob clockwise while the machine is running until the stock goes through. **NOTE: Turn the retarder no more than 1/4 turn. Turning the retarder more than this may damage the feed wheel.**

3. Repeat with a single sheet of stock on the other machine levels. See Figure #12.
Note that the full 8 ½” by 11” sheet goes on the lowest bin, the slit product of that bin then is run through the level above.

Loading 8 ½” X 11” Stock in lowest bin

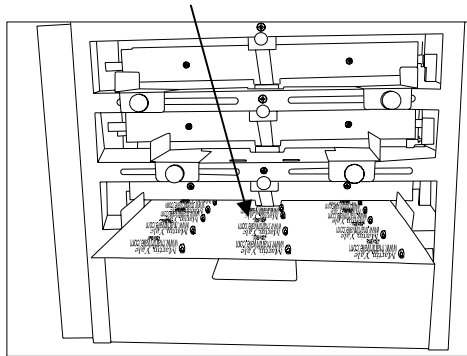

Figure #11

Loading product of lowest bin into the bin above

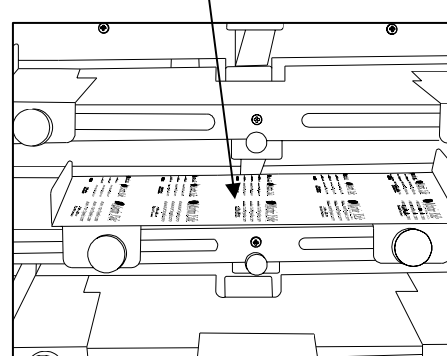

Figure #12

4. Once you are comfortable with the single sheet performance of card slitting, a stack of stock may be slit. **WARNING: Only install stock into the slitter while it is ‘off’. Attempting to load stock while the slitter is running may result in injury or damage to the machine.**
5. Turn slitter ‘ON’, it should feed and slit the stock one sheet at a time. If double feeds or hesitates, follow the steps below:
 - a. Paper guides too tight will result in hesitant feeds; try loosening paper guides slightly as outlined in Section III.
 - b. Retarder too loose or too tight will result in double or hesitant feeds. Slightly adjust retarder as outlined under retarder adjustment in Section III. Usually only a slight turning of the retarder adjustment knob is needed to allow the slitter to function.
 - c. For difficult to feed stocks, substantial improvement can be made in feeding through the use of the supplied stack weights. See Figure #13 for correct use of stack weights. They can significantly improve the feed of curled or otherwise difficult to feed stock.

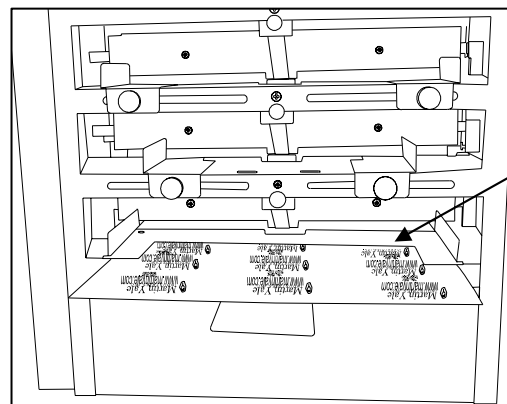

Figure #13



251 Wedcor Avenue • Wabash, Indiana 46992
 Ph# (260) 563-0641 • Fax# (260) 563-4575
 email: info@martinyale.com • website: www.martinyale.com