

# Martin Yale W Series Premier Paper Trimmers

## Instruction Manual



Provided By

**MyBinding**.com®  
*When Image Matters.*

# Premier® Heavy-Duty Paper Trimmers

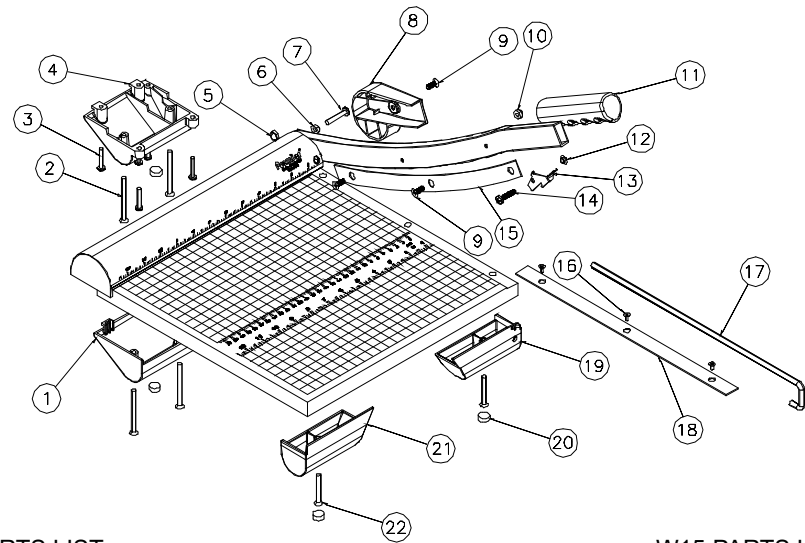

W12 PARTS LIST

W15 PARTS LIST

Part Number	Description	Qty.	
1	M-O017909	LEFT REAR FOOT	1
2	M-S004018	#10 X 2 1/4 LOROOT FLHD	4
3	M-S004078	#8 X 7/8 PH PAN HD LR	5
4	M-O017951	RIGHT REAR FOOT	1
5	M-S007010	10-32 ACORN NUT	1
6	M-S6100058	10-32 HEX NUT	1
7	M-S001149	10-32 X 1.13 P/PH B/O	1
8	M-O017911	HANDLE CAP	1
9	M-S001020	10-32 X 1/2 PHIL UC FH	3
10	M-S007033	HEX ACORN NUT, 10-32	1
11	M-S043013	7/8 MAROON GRIP	1

Part Number	Description	Qty.	
12	M-O017642	LATCH SPACER	1
13	W-O017651	SMALL SAFETY LATCH	1
14	M-S001148	10-32 X 7/8 PHL. P/HB/O	1
15	W-O175012	12" CURVED BLADE	1
16	M-S004063	#8 X 5/8 LR. W/#6 PH. F.H.	3
17	W-O017949	FINGERGUARD	1
18	W-O010512	12" STRAIGHT BLADE	1
19	M-O017906	RIGHT FOOT	1
20	M-S030010	T BUMPER (FOOT)	4
21	M-O017905	LEFT FOOT	1
22	M-S004016	#10 X 1 1/2 LOROOT FLHD	2

Part Number	Description	Qty.	
1	M-O017909	LEFT REAR FOOT	1
2	M-S004018	#10 X 2 1/4 LOROOT FLHD	4
3	M-S004078	#8 X 7/8 PH PAN HD LR	5
4	M-O017951	RIGHT REAR FOOT	1
5	M-S007010	10-32 ACORN NUT	1
6	M-S6100058	10-32 HEX NUT	1
7	M-S001149	10-32 X 1.13 P/PH B/O	1
8	M-O017911	HANDLE CAP	1
9	M-S001020	10-32 X 1/2 PHIL UC FH	4
10	M-S007033	HEX ACORN NUT, 10-32	1
11	M-S043013	7/8 MAROON GRIP	1

Part Number	Description	Qty.	
12	M-O017642	LATCH SPACER	1
13	W-O017651	SMALL SAFETY LATCH	1
14	M-S001148	10-32 X 7/8 PHL. P/HB/O	1
15	W-O017735	15" CURVED BLADE	1
16	M-S004063	#8 X 5/8 LR. W/#6 PH. F.H.	4
17	W-O017950	FINGERGUARD	1
18	W-O010615	15" STRAIGHT BLADE	1
19	M-O017906	RIGHT FOOT	1
20	M-S030010	T BUMPER (FOOT)	4
21	M-O017905	LEFT FOOT	1
22	M-S004016	#10 X 1 1/2 LOROOT FLHD	2

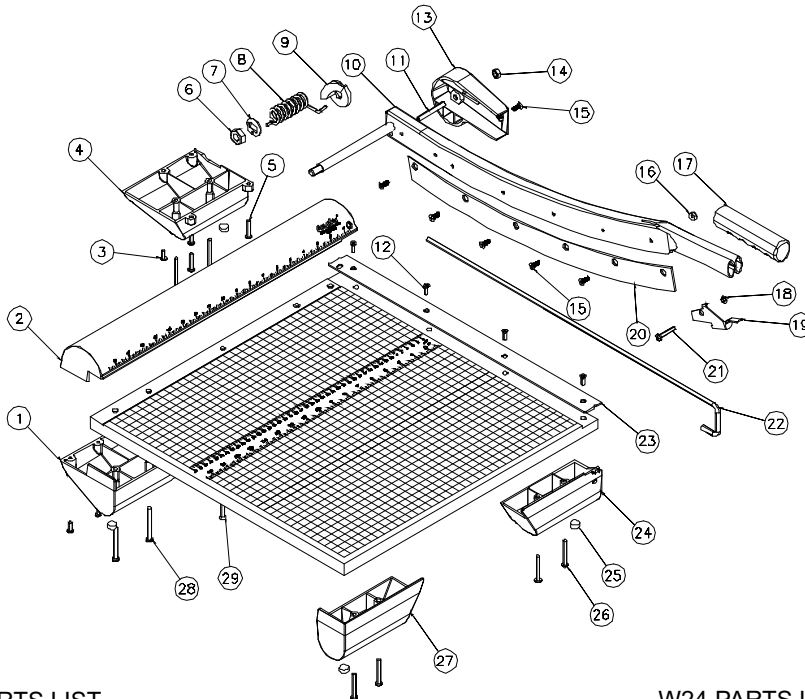
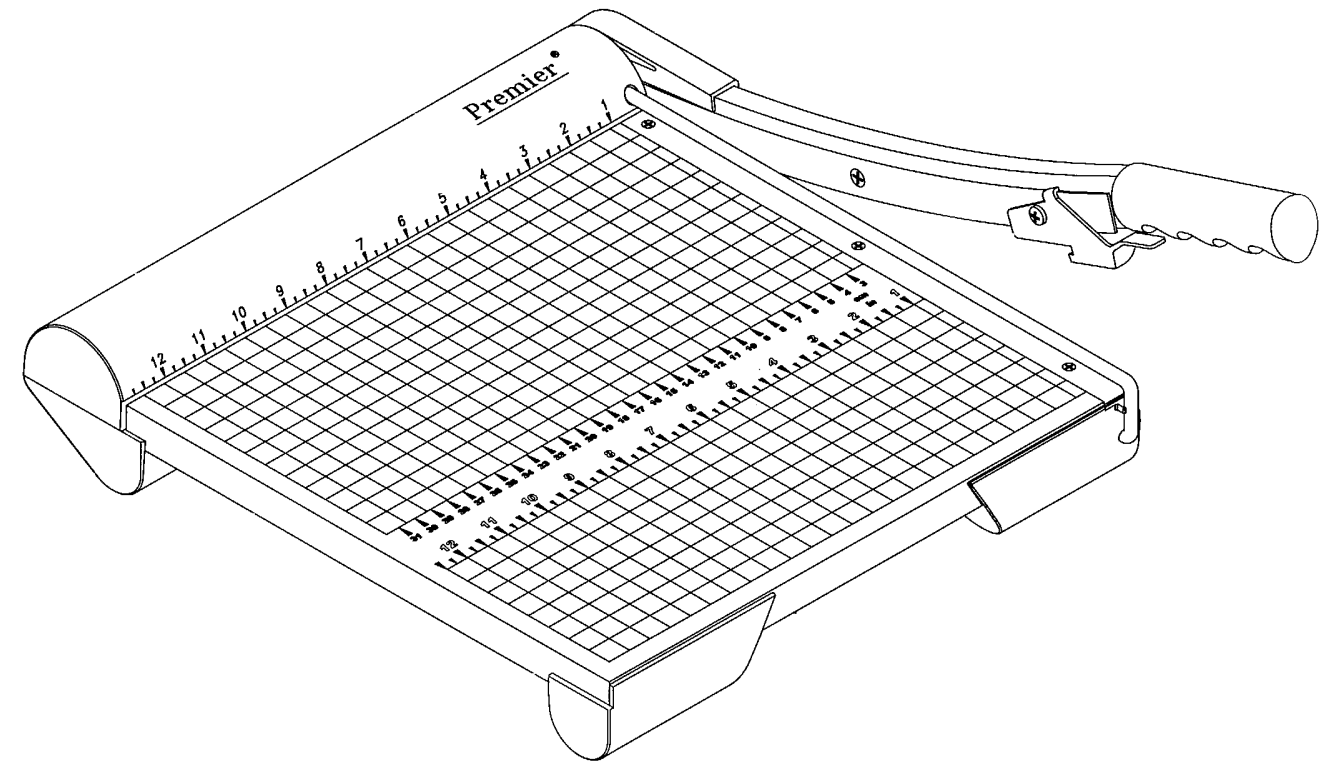

W18 PARTS LIST

W24 PARTS LIST

Part Number	Description	Qty.	
1	M-O017946	W18 & 24 L/REAR FOOT	1
2	W-F017920	W18 & 24 BEARING COVER	1
3	M-S001169	#8 X 1/2 PH. PH. "B" ZINC	4
4	M-O017919	W18 & 24 R/REAR FOOT	1
5	M-S004078	#8 X 7/8 LO ROOT PHIL	2
6	M-S007026	1/2-13 HEX LOCK NUT	1
7	W-O001757	TORQUE WASHER	1
8	M-S031053	LG. TRIMMER SPRING	1
9	M-O017927	W18 & 24 HELICAL WEAR PAD	1
10	W-A017926	W18 BLADE/HANDLE ASSY	1
11	M-S002024	1/4-20X2 CUP PNT. SET SCREW	1
12	M-S004063	#8 X 5/8 W/#6 PHL. F/H SCREW	4
13	M-O017918	W18 & 24 HANDLE CAP	1
14	M-S007017	1/4-20 HEX NUT FULL	1
15	M-S001020	10-32 X 1/2 PHIL UC FH	6

Part Number	Description	Qty.	
16	M-S007033	HEX ACORN NUT, 10-32	1
17	M-S043016	1" HAND GRIP, MAROON	1
18	M-O017642	LATCH SPACER	1
19	W-O017652	LARGE SAFETY LATCH	1
20	W-O017518	18" CURVED BLADE	1
21	M-S001149	10-32 X 1.13 P/PH B/O	1
22	W-O017947	W18 FINGER GUARD	1
23	W-O010518	18" STRAIGHT BLADE	1
24	M-O017908	W18 & 24 R/FRONT FOOT	1
25	M-S030010	T BUMPER (FOOT)	4
26	M-S004039	#10 X 1.5 PHL. P/H SCREW	4
27	M-O017907	W18 & 24 L/FRONT FOOT	1
28	M-S004050	#10 X 2 PH. RD LO-ROOT	4
29	M-S004017	#10 X 1.25 PHL. F/H SCREW	1

Part Number	Description	Qty.	
1	M-O017946	W18 & 24 L/REAR FOOT	1
2	W-F017920	W18 & 24 BEARING COVER	1
3	M-S001169	#8 X 1/2 PH. PH. "B" ZINC	4
4	M-O017919	W18 & 24 R/REAR FOOT	1
5	M-S004078	#8 X 7/8 LO ROOT PHIL	2
6	M-S007026	1/2-13 HEX LOCK NUT	1
7	W-O001757	TORQUE WASHER	1
8	M-S031053	LG. TRIMMER SPRING	1
9	M-O017927	W18 & 24 HELICAL WEAR PAD	1
10	W-A017929	W24 BLADE/HANDLE ASSY	1
11	M-S002024	1/4-20X2 CUP PNT. SET SCREW	1
12	M-S004063	#8 X 5/8 W/#6 PHL. F/H SCREW	5
13	M-O017918	W18 & 24 HANDLE CAP	1
14	M-S007017	1/4-20 HEX NUT FULL	1
15	M-S001020	10-32 X 1/2 PHIL UC FH	8

Part Number	Description	Qty.	
16	M-S007033	HEX ACORN NUT, 10-32	1
17	M-S043016	1" HAND GRIP, MAROON	1
18	M-O017642	LATCH SPACER	1
19	W-O017652	LARGE SAFETY LATCH	1
20	W-O017524	24" CURVED BLADE	1
21	M-S001149	10-32 X 1.13 P/PH B/O	1
22	W-O017948	W24 FINGER GUARD	1
23	W-O010524	24" STRAIGHT BLADE	1
24	M-O017908	W18 & 24 R/FRONT FOOT	1
25	M-S030010	T BUMPER (FOOT)	4
26	M-S004039	#10 X 1.5 PHL. P/H SCREW	4
27	M-O017907	W18 & 24 L/FRONT FOOT	1
28	M-S004050	#10 X 2 PH. RD LO-ROOT	4
29	M-S004017	#10 X 1.25 PHL. F/H SCREW	1

## Key Features and Benefits

- Heavy-duty 3/4" thick wood base
- Fully-hardened self-sharpening steel blades cut up to 20 sheets
- Accurately cuts paper, matte board, cardboard, film, tissue, and textiles
- Permanent 1/2" grid and dual rulers for proper paper alignment
- Patented automatic blade latch locks with every cutting motion
- Finger guard helps protect the entire blade length
- Torsion spring counterbalances blade arm
- Non-skid feet

## Model Numbers

- W12 – 12" cutting length
- W15 – 15" cutting length
- W18 – 18" cutting length
- W24 – 24" cutting length



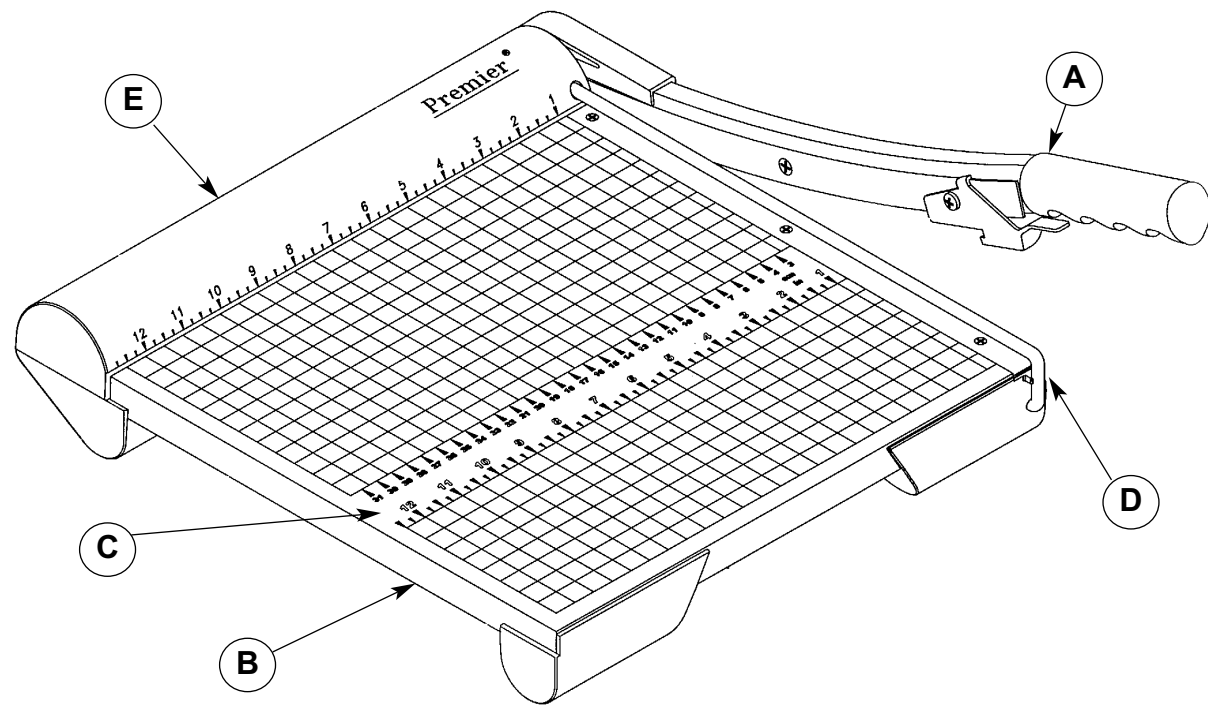

### Key Components

- A – Hand Grip/Blade Arm/Blade Latch Assembly
- B – Wood Base with Molded End Caps
- C – Alignment Ruler
- D – Finger Guard
- E – Paper Guide Ruler

### Assembly Instructions

Place the non-skid rubber feet into position on the bottom of the trimmer.

### Automatic Safety Latch

The patented automatic blade latch is a key safety feature of this trimmer. It will lock with every complete cutting stroke, helping to eliminate forgetfulness. Remember to always push the blade arm down completely when you are finished cutting, to ensure that the latch activates. Never remove the latch for any reason.

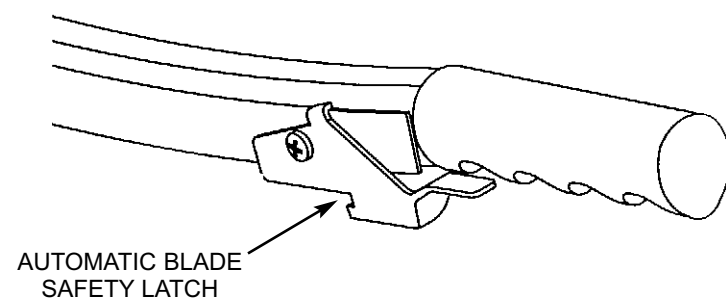

### Operating Instructions

1. Place the trimmer on a flat, stable surface
2. Release the blade latch, which is located on the hand grip (A)
3. Lift the blade arm (A) up into cutting position
4. Using the rulers or the 1/2" grid, align the paper to the proper position, pushing it up against the paper guide ruler (E).

**CAUTION:**  
Keep hands and fingers behind the finger guard (D)  
at all times, away from the cutting blades

5. While holding the paper down with your left hand (to make sure it stays in place), pull down the blade arm (A) to cut.
6. Always make sure that the blade arm is completely down and locked when not in use.

**ATTENTION:**  
Do not force the blade arm  
upward beyond the natural  
stop position.

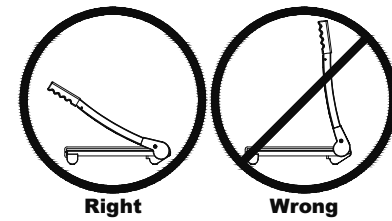

### Safety Information

- Always ensure that the blade arm is fully pushed down, and that the blade latch is engaged, when not in use
- Never operate the trimmer without the finger guard in place
- Always keep clothing, jewelry, watches, and hair away from the cutting blade
- Keep out of the reach of children
- Do not carry the trimmer by the hand grip or the blade arm

### For Best Cutting Performance

Use Trim-Ease Blade Lubricant for a smoother cut and to help preserve the life of the cutting blade. To order, send \$5.50 per stick and a self-addressed, stamped envelope to the address below.

### Customer Service

**Telephone:** (260) 563-0641  
**Fax:** (260) 563-4575  
**Email:** info@martinyale.com  
**Internet:** www.martinyale.com  
**Address:** Martin Yale Industries, Inc.  
 251 Wedcor Avenue  
 Wabash, IN 46992



Visit [www.martinyale.com](http://www.martinyale.com) for information on office products, including paper folding machines, punches, letter openers, catalog racks, and computer keyboard drawers.