

MBM Auto Booklet Maker

Instruction Manual



Provided By

MyBinding.com®
When Image Matters.

Auto BookletMaker

Instruction Manual

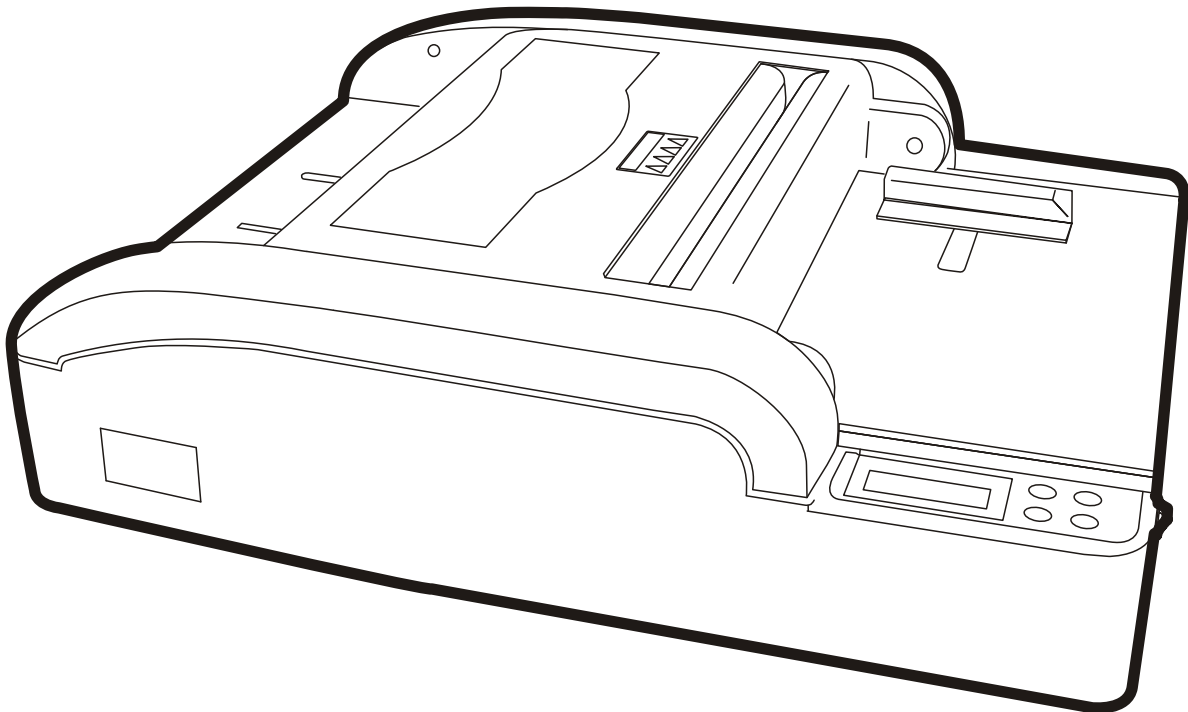

Contents

| | |
|--|---------|
| Introduction | P.2 |
| Safety Precautions | P.3 |
| Safety Precautions | P.4 |
| Usage Precautions | P.5 |
| Specifications | P.6 |
| Part Names | P.7 |
| Accessories | P.7 |
| Control Panel | P.8 |
| Installation | P.9 |
| Operation | P.10-19 |
| Standard Paper Size Selection. | P.10 |
| Non Standard Paper Size Data Input. | P.11 |
| Memory Call Out. | P.12 |
| Trigger Timer Setting. | P.13 |
| Correcting Folding or Stapling Misalignment. | P.14-15 |
| Factory Default Setting. | P.16 |
| Serial Number indication. | P.17 |
| Booklet Making. | P.18 |
| Counter Reset. | P.19 |
| Emergency Stop. | P.19 |
| Remove Jammed Staple From Stapler Head. | P.19 |
| Error Message | P.20 |
| Daily Care | P.20 |



Introduction

Thank you for your purchase of this Booklet Maker.
To ensure correct usage, please read this instruction manual thoroughly, especially the section Safety Precautions. After reading, please keep this instruction manual handy for future reference.





Safety Precautions

Always observe the cautions and warnings given below to prevent personal injury or property damage.

- The degree of danger and damage that could occur is indicated on two levels by the following marks.

-  **WARNING** : Ignoring this mark could result in the possibility of serious injury or even death.
-  **CAUTION** : Ignoring this mark could result in the possibility of injury or physical damage.

- The following graphic symbols indicate the various types of action to be performed or avoided.

-  This graphic symbol indicates a forbidden action.
 -  means "Do not disassemble."
 -  means "Do not touch."
-  This graphic symbol indicates actions that must be performed.
 -  means "Disconnect the power plug."

WARNING:



Do not place metal objects or vessels containing liquids on top of the unit. The entry of any metal object or liquid could result in fire or electrical shock.



Do not insert any metal or easily-combustible object inside this unit. This could result in fire or electrical shock.



Do not touch or insert foreign objects into any rotating part during operation. This could result in injury.



Do not remove the cover or back panel. This unit contains high-voltage components that could cause electrical shock.



Do not disassemble, modify or repair this unit. There is a danger of fire, electrical shock or injury. Contact your dealer when repairs are necessary.



Use only the power supply voltage specified on the main nameplate. Using other voltages could result in fire or electrical shock.



Keep this unit and the power cord away from heaters and heater vents. Excessive heat could melt the cover or power cord covering, and result in fire or electrical shock.

Safety Precautions (Continues)



Make sure that the combined power consumption of the appliances to be connected does not exceed the capacity rating of the power outlets or plug receptacles. Exceeding the capacity rating could cause the power outlets, plug receptacles, or power extension cords to overheat and catch fire.



Remove any dust that accumulates on the power plug prongs and the surface of the plug from which the prongs extend. Accumulated dust could result in fire.



If any foreign object such as metal or liquid should enter this unit, immediately turn the unit off at the power switch and disconnect the power plug from the power outlet. Failure to do so could result in fire or electrical shock. Contact your dealer immediately.



Do not damage the power cord or power plug. (Do not scratch, alter, bend, twist, pull or place heavy objects on the power cord or power plug.) This could result in damage, fire or electrical shock.



Always grip the plug when disconnecting the power plug from the power outlet. Forcibly pulling the power cord could cause damage, resulting in fire or electrical shock.



Do not handle the power plug with wet hands. This could result in electrical shock.



Before cleaning this unit, turn the unit off at the power switch and disconnect the power plug from the power outlet. Accidental operation of the unit during cleaning could result in injury.



Do not touch the power switch with wet hands. Otherwise electric hazards may occur.



Do not use flammable sprays inside or near the unit (e.g. when cleaning the unit). Such flammable gas may ignite and cause fire or combustion.

CAUTION:



Keep away long hair, ties, jewelry and loose clothing. This could result in injury.



Do not use solvent inside or near the unit (e.g. when cleaning the unit). Such solvents may damage the rubber rollers and resin inside the unit, resulting in malfunctions.



Always disconnect the power plug from the power outlet when the unit is not to be used for an extended period. Failure to do so could result in fire due to leakage current if the insulation should deteriorate.



Install this unit on a level, stable stand or floor, with sufficient space around it. Failure to do so could result in the unit overturning and causing injury.



Do not install this unit in a location where there is excessive humidity or where contact with water is possible. Poor choice of location could result in deterioration of the insulation, fire or electrical shock.



Disconnect the power plug from the power outlet before attempting to move this unit. Failure to do so could result in power cord damage, fire or electrical shock.

Usage Precautions

Power Supply

- ◆ This equipment shall be installed near the socket-outlet where the plug on the power supply cord is easily accessible.
- ◆ Make sure the power supply used is always within the following range.
 - 220 - 240VAC, 50Hz in Europe.
 - 110VAC, 60Hz in United State.
- ◆ When you power other appliances from the same AC outlet, make sure that the combined power consumption does not exceed the power supply capacity.
 - Rated power of this equipment: 75 W
- ◆ For continued protection against risk of fire, replace only with same type and rating of fuse.

Operating Environment

Operate this unit in the following environment:

- ◆ Where the temperature range is between 5 and 35°C.
- ◆ Where the humidity range is between 10 and 80% RH (no dew condensation).
- ◆ Which is not subject to direct sunlight,
- ◆ Where the equipment is not exposed to water.

Specifications

| | | |
|----|------------------------------|--|
| 1 | Maximum paper size | 297mm x 432mm 11¾" x 17" |
| 2 | Minimum paper size | 182mm x 257mm 7¼" x 10½" |
| 3 | paper size | A3, B4, F4A, F4B and A4 (Asia) A3, B4, LG, A4 and B5 (Europe) LD, A3, LG, A4 and LT (U.S.A.) |
| 4 | Stapling method | Automatic Stapler Heads |
| 5 | Stapling and folding ability | Equivalent to 15 sheets of 80gsm (20#) bond paper or below |
| 6 | Maximum processing speed | 7 sets / minute |
| 7 | Number of stapler head | 2 |
| 8 | Staple head capacity | 100 staples each |
| 9 | Operation mode | Automatic |
| 10 | Paper size setting | Button select |
| 11 | Fine adjustment | Button setting, auto positioning |
| 12 | Counter | 4 digit |
| 13 | Dimension | W x D x H 560,mm x 455mm x 166mm 22" x 18" x 6¾" |
| 14 | Weight | 20 Kg / 44 lbs |
| 15 | Power consumption | 80W |
| 16 | Power supply | 220V/50Hz (Asia / Europe) 110V/60Hz (U.S.A.) |

Specifications are subject to change without prior notice for improvements.

Paper size reference:

A3 = 297mm x 420mm
A4 = 210mm x 297mm
F4A = 216mm x 343mm
F4B = 216mm x 330mm

LD = 11" x 17"
LG = 8½" x 14"
LT = 8½" x 11"

B4 = 257mm x 364mm
B5 = 182 mm x 257mm

Part Names

- | | | |
|--------------------|------------------|----------------------|
| 1. Stapler assy. | 5. Clincher | 9. Top cover |
| 2. Paper guide | 6. Control panel | 10. folding roller |
| 3. Side cover | 7. Scale | 11. stapler head |
| 4. Pressing roller | 8. power switch | 12. Paper side guide |

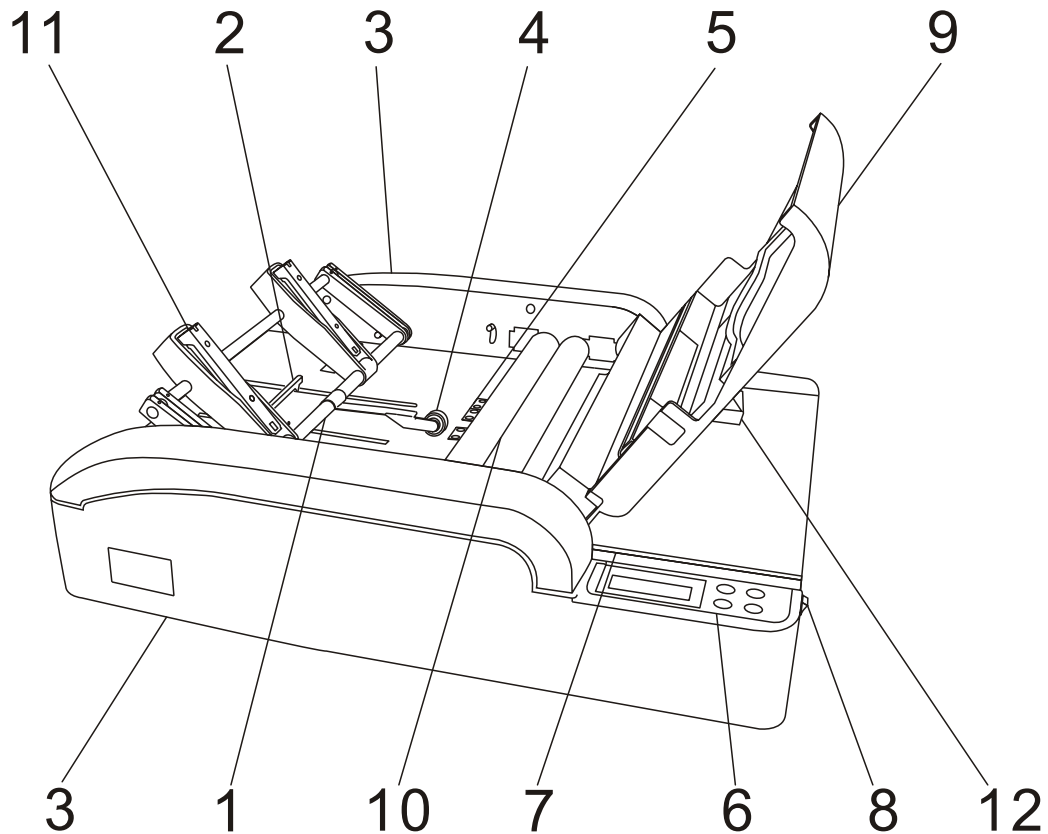

Accessories

Option Stoppers

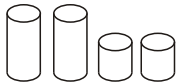

Paper Side Guide



Press roller

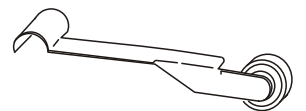

Power Cord (U.S.A. Version)

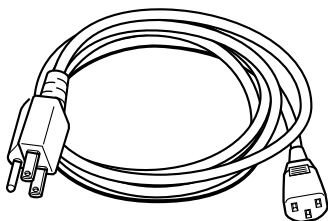

Power Cord (Europe Version)

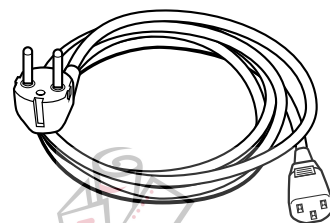

Control Panel

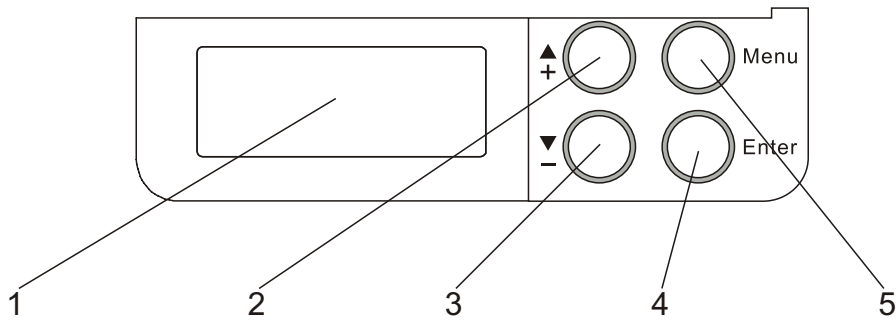

| No | Name | Operation |
|----|--------------------|---|
| 1 | LCD Display | <p>Light up when power on</p> <p>Selected paper size and counter indicate when power on</p> <p>Option menu indicate when press the Menu button</p> <p>Error message indicate when error occur</p> |
| 2 | Scroll up button | <p>Press the button to change the size of standard paper</p> <p>Press the button to select the options of menu</p> <p>Press the button to change the size of non standard paper under option menu</p> |
| 3 | Scroll down button | <p>Press the button to change the size of standard paper</p> <p>Press the button to select the options of menu</p> <p>Press the button to change the size of non standard paper under option menu</p> |
| 4 | Enter button | <p>Press the button to enter the revised setting</p> <p>Press the button to confirm the setting finished</p> <p>Press the button to return to standby mode</p> |
| 5 | Menu button | <p>Press the button to enter the option menu</p> <p>Press the button to escape from the option menu</p> |

Installation

- 1** Open the top cover and get rid off the wire tie from the folding roller.
- 2** Lift up the stapler head lever. Then remove the sponge pad under the stapler head.
- 3** Open the cassette from the stapler head and load staples.
- 4** Move the stapler heads to certain position which are matching the paper size.
- 5** Close the top cover and plug in the power cord.

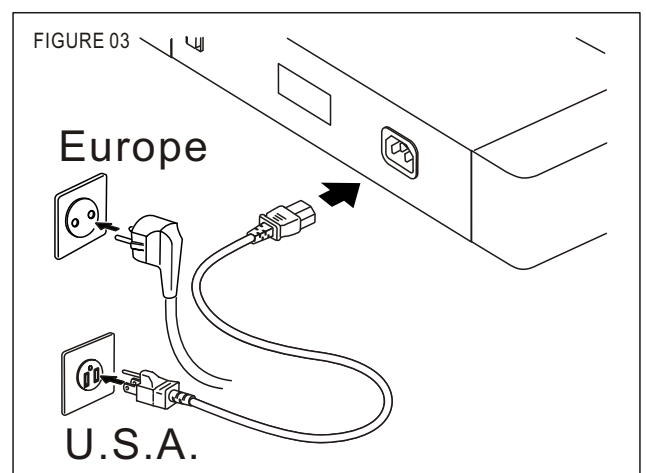
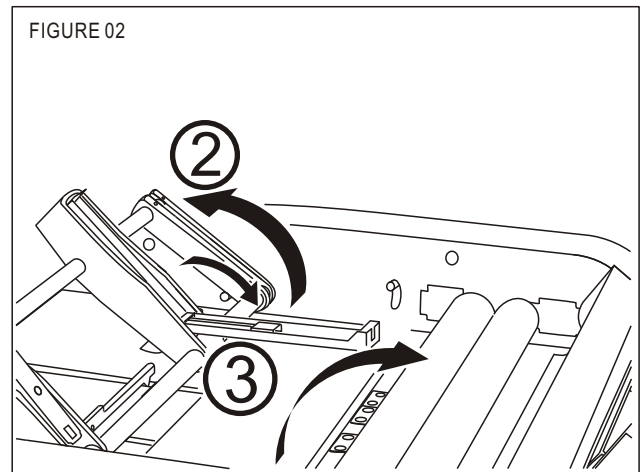
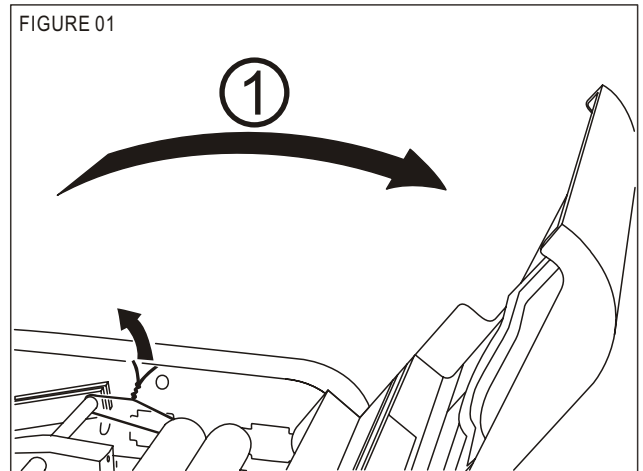

Please check the power requirement of the machine from the serial number tag before plug in the power cord.

Operation

Standard Paper Size Selection.

1 Switch the power on. (See fig. 04)

2 Select the paper size by pressing scroll up or scroll down button. (Example LD paper)

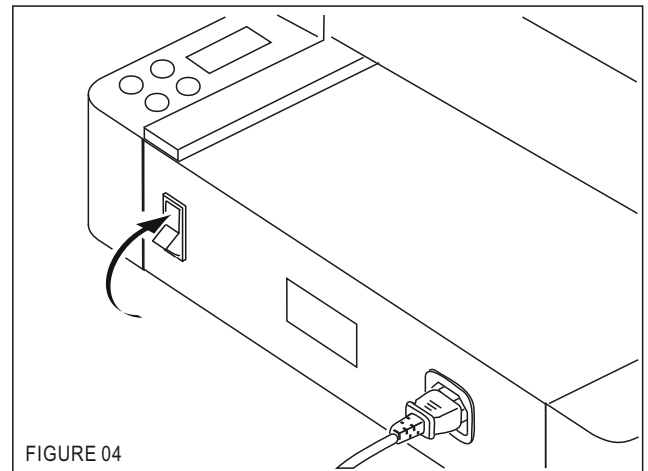
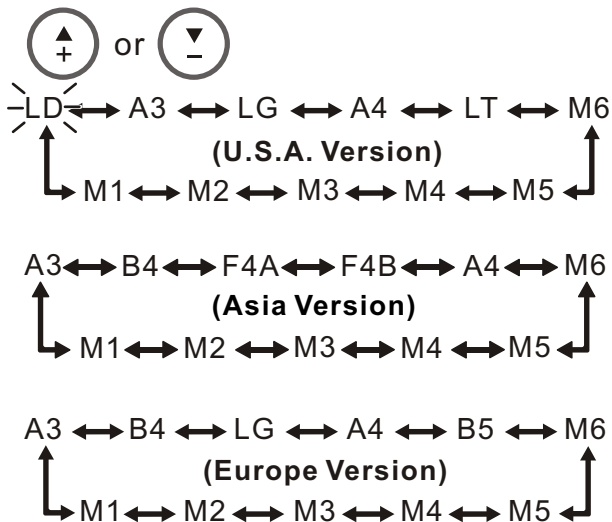

FIGURE 04

3 Press Enter button.



size: LD ?
Reset staples !

4 Move the stapler heads to the correct position by following the stapler head position sticker. (See fig.5)

Reference sticker is located in the back of the top cover.



5 Press Enter button to return to ready.



Size LD Adj +00
Ready 0000Set

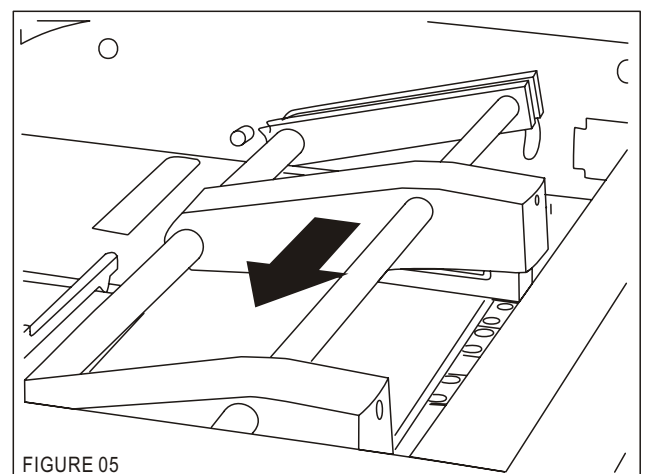

FIGURE 05

Operation

Non Standard Paper Size Data Input.

- 1 Press Menu button to enter option menu.



1.Memo 2.Time
3.F-Adj 4.S-Adj

- 2 Select "1.Memo" then press enter button.



Mem1 Mem2 Mem3
Mem4 Mem5 Mem6

- 3 Select one of Memory from Mem1 to Mem6 by pressing scroll button then press Enter button to enter paper size setting. (For example Mem2)



Mem1 Mem2 Mem3
Mem4 Mem5 Mem6



Memory Size
Mem2: 297mm

- 4 Press down and hold scroll button to change the size of the paper until the value is reach to require value. (Example 250mm)



Memory Size
Mem2: 297mm



Memory Size
Mem2: 250mm

- 5 Press Enter button to input the data to Memory No.2 and return to ready.



Size M2 Adj +00
Ready 0000Set

Operation

Memory Call Out.

- 1 Memory call out by press scroll up or scroll down button. (Example M3)

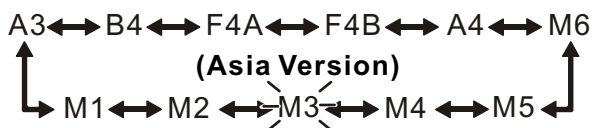
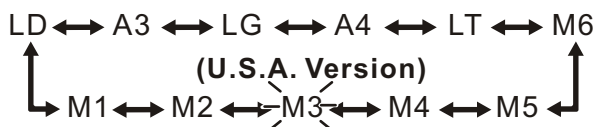
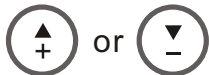

- 2 Press Enter button to enter.



size: M3 ?
Reset staples !

- 3 Move the stapler heads to the correct position based upon paper size.

- 4 Press Enter button to return to ready.



Size M3Adj +00
Ready 0000Set

Operation

Trigger Timer Setting.

- 1 Press Menu button to enter option menu.



1. Memo 2. Time
3. F-Adj 4. S-Adj

- 2 Select 2. Time by press scroll down button.



1. Memo 2. Time
3. F-Adj 4. S-Adj

- 3 Press Enter button to enter trigger timer setting.



Stapling Time
05 second

- 4 Press scroll up or down button to change the setting. (Example 8 second)



Stapling Time
08 second

- 5 Press Enter button to rewrite the previous value and return to ready.



Size M3Adj +00
Ready 0000Set

Operation

Correcting Folding or Stapling Misalignment.

- 1 Fold the book manually to make the center line on the book.
- 2 Check the staples aligning with the center line or not.
- 3 Fine adjustment by following the instruction below.

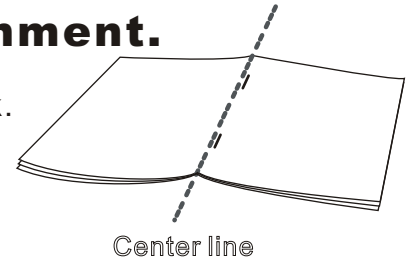









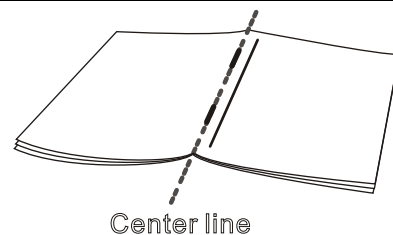

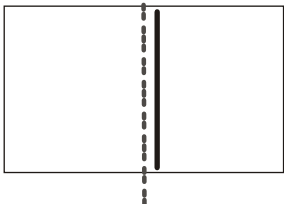

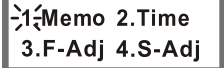

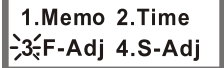

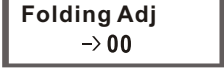

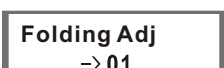

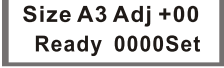
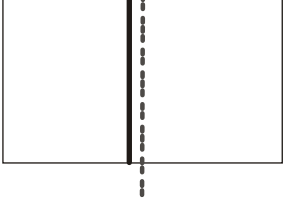

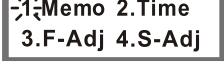
| Align with center line | Staple position | Adjustment | Indication |
|------------------------|--|---|------------|
| No | Staple located on the right side of the center line. | 1. Press Key. | |
| | | 2. Press shift to 4.S-Adj. | |
| | | 3. Press Key. | |
| | | 4. Press move the paper to left. (Paper move left 0.14mm for 1 digit) | |
| | | 5. Press return to "Ready". | |
| | Staple located on the left side of the center line. | 1. Press Key. | |
| | | 2. Press shift to 4.S-Adj. | |
| | | 3. Press Key. | |
| | | 4. Press move the paper to right. (Paper move right 0.14mm for 1 digit) | |
| | | 5. Press return to "Ready". | |
| Yes | | 1. Go to next step 4. | |

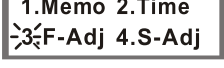
Repeat Step 3. Until stapling align with center line.

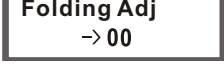
Operation

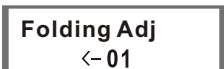
- 5 Check folded position aligning with the center line or not.
- 6 Fine adjustment by following the instruction below.

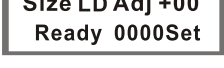
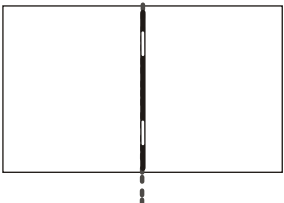

| Align with center line | Staple position | Adjustment | Indication |
|------------------------|--|--|---|
| No | Fold located on the right side of the center line.  | 1. Press  Key. |  |
| | | 2. Press  shift to 3.F-Adj. |  |
| | | 3. Press  Key. |  |
| | | 4. Press  move the paper to left. (Paper move left 0.14mm for 1 digit) |  |
| | | 5. Press  return to "Ready". |  |
| | Fold located on the left side of the center line.  | 1. Press  Key. |  |
| | | 2. Press  shift to 3.F-Adj. |  |
| | | 3. Press  Key. |  |
| | | 4. Press  move the paper to right. (Paper move right 0.14mm for 1 digit) |  |
| | | 5. Press  return to "Ready". |  |
| Yes |  | 3. Fine adjustment finished. |  |

Repeat Step 6 until fold is aligned with center line.

Operation

Factory Default Setting.

- 1 Press Menu button to enter option menu.



1 Memo 2.Time
3.F-Adj 4.S-Adj

- 2 Select 5 "Reset all" by pressing scroll down button.



1.Memo 2.Time
3.F-Adj 4.S-Adj → 5.Reset all.
6.Show serial.

- 3 Press Enter button to reset all data to factory default setting.

Warning! All the value in Memory will be restored to factory default value (297mm)also.



Reset all data → Data restored
015 +005

- 4 Press Enter button to return to ready.



SizeLD Adj +00
Ready 0000Set

Operation

Serial Number Indication.

- 1 Press Menu button to enter option menu.



1. Memo 2. Time
3. F-Adj 4. S-Adj

- 2 Select 6 "Show serial" by pressing scroll down button.



1. Memo 2. Time
3. F-Adj 4. S-Adj



5. Reset all.
6. Show serial.

- 3 Press Enter button to check the serial number.



Machine Serial:
H XXXXXXXXX

- 4 Press Enter button to return to ready.



Size LDAdj +00
Ready 0000Set

Operation

Booklet Making.

- 1** Select the required paper size and adjust the stapler head position by reference to page 11 to page 13.
- 2** For example LD paper selected.
- 3** Open the top cover and insert a set of A3 paper. (See fig. 6)
Align the paper with the edge of the scale.
- 4** Place the paper side guide by aligning it the edge of the paper. (See fig.7)
- 5** Use optional magnetic stops if required. (See fig.8)
- 6** Close the top cover. Then the machine will start to work in 5 seconds.
- 7** Insert paper for next book. (See fig. 9)

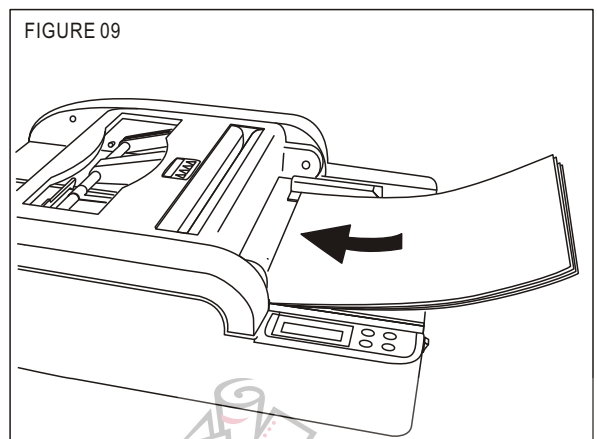
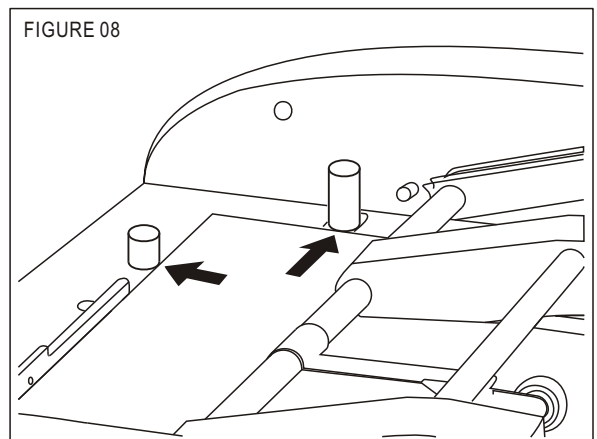
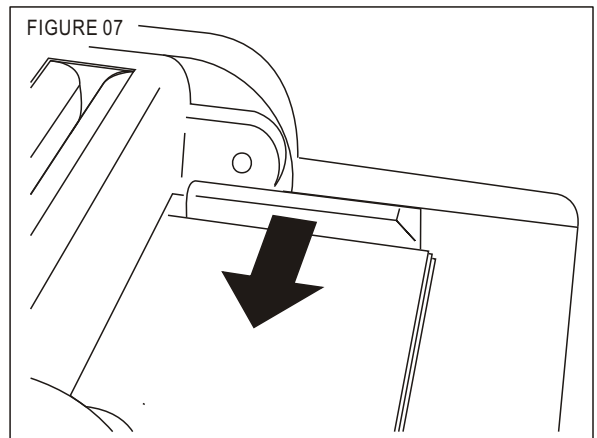
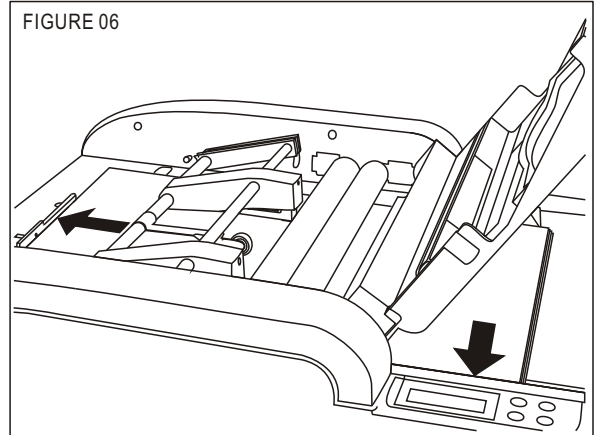

Operation

Counter Reset.

- 1 Remove all the paper from the machine.
- 2 Press Enter button to reset the counter to "0000"



Emergency Stop.

- 1 Press any button on the panel to stop the machine during the booklet making process.

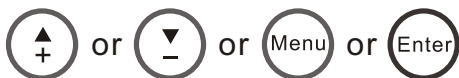

- 2 Switch off the machine then power on the machine to return to ready.



Remove Jammed Staple From Stapler Head.

- 1 Open the top cover and lift up the stapler head lever.
- 2 Open the cassette from the stapler head and remove the jammed staple by using tweezers.

Error Message

| Error Message | Causes | Trouble shooting |
|---|---|--|
| Size LD Adj +00 Cover is open! | Top cover opened in the ready state. | Close the top cover. |
| Cover is open | Top cover opened during booklet making. | Close the top cover. Then press enter button. |
| Reset? | Close the cover after "Cover is open" indicated. | Press enter button to reset the machine. |
| Over loading! Take away paper | Too many paper loaded on the machine cause motor overload. | Remove all the paper from the machine. Then turn off power for 3 second. Power on the machine to ready. |
| Emergency stop! Reset machine! | One of key pressed during booklet making. | Turn off power for 3 second. Then turn on the machine. |

Daily care

Use a soft clean cloth dampened with alcohol or neutral detergent when cleaning. Before cleaning, be sure to turn off the power. The folding rollers may cause paper slipping or smudging with paper dust or ink if they are dirty.

Always disconnect the power plug from the outlet after used.