

MBM Sprint 5000 Booklet Maker

Instruction Manual



Provided by

MyBinding.com
When Image Matters.

Call Us at 1-800-944-4573

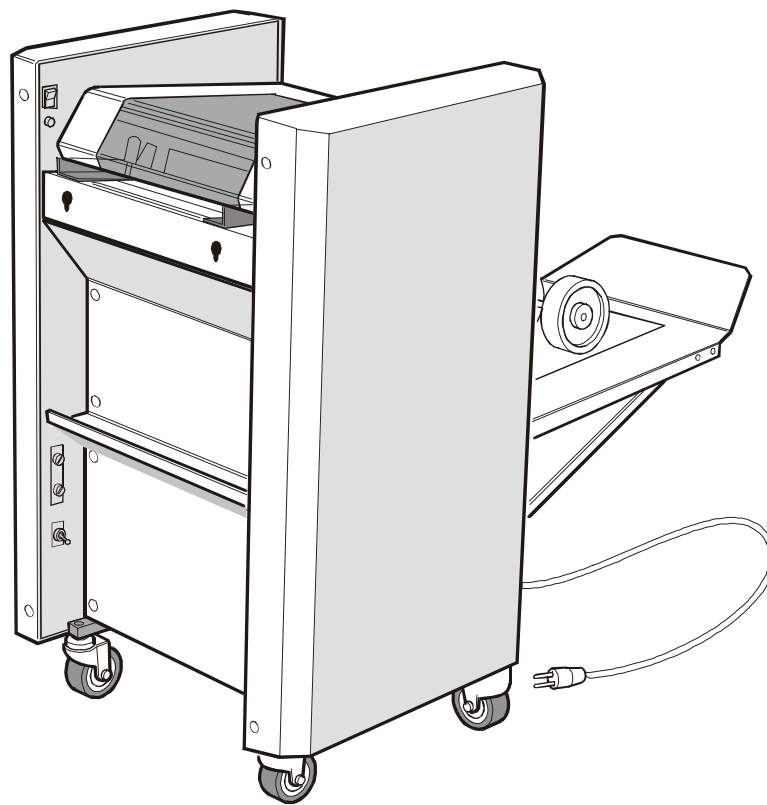

SPRINT 5000

BOOKLETMAKER

OPERATION MANUAL

CONTENTS

1.	Introduction.	2
2.	Specification.	2
3.	Initial setting up.	3
4.	Operation.	4
	4.1 Loading staples.	5
	4.2 Staple out system.	7
	4.3 Staple jam.	7
	4.4 Paper width settings.	8
	4.5 Stapling / folding positions.	9
	4.6 Changing stapling head positions.	11
5.	Booklet making.	12
6.	Corner and edge stapling.	14
7.	Counter.	17
8.	Replacing stapling heads.	17
9.	Aligning of stapling heads.	17
10.	Problem solving.	18

Appendix A: Parts lists and drawings.

MBM Corporation
Michael Business Machines
3134 Industry Drive
North Charleston
South Carolina 29418

Customer Service - Tel: (800) 223 2508
Fax: (803) 552 2974
Parts & Service - Tel: (800) 223 2508
Fax: (803) 760 3814



1 INTRODUCTION

- The Sprint 5000 Bookletmaker centre staples and folds to make booklets between 4" x 5½" and 8½" x 11" with up to 80 pages. On each cycle of the machine one set of sheets is stapled and the preceding set is folded and stacked on the conveyor belt.
- It is also possible to edge and corner staple up to 20 sheets.
- The machine can either be hand fed or placed on-line to one of the various desktop vertical collators, using a KAS conveyor/ jogger link. A stand is also supplied to carry the collator so that it is the correct height for feeding into the Bookletmaker.
- The Sprint 5000 is a floor standing machine fitted with sturdy castors and an integral conveyor which can be folded up in order to occupy minimal floor space when not in use.
- This model has five stapling positions to which the stapling heads can be moved according to the size of paper. The right hand outside position is for corner stapling.
- A Staple Out Detector is fitted to each of the stapling heads, and the Bookletmaker will stop when the stapling head runs out of staples.

2 SPECIFICATION

INPUT CAPACITY:	Booklets	20 sheets of 20 lb bond
	Pads	20 sheets of 20 lb bond
SHEET SIZES:	Booklets	5½" x 8" to 11½" x 17½".
	Pads	8½" x 11½"
STAPLES		5000 staple cartridge
DIMENSIONS		Width 23" Height 36" Length 20" (Conveyor stored). Length 46" (Conveyor in use).
WEIGHT		205 lbs.
POWER		115v 60Hz Consumption approx. 180 Watts Fuse: 10 amp 115v.

3. INITIAL SETTING UP

1. Remove the bolts holding the machine to the pallet.
2. Castors are already fitted to the machine, lift from the pallet on to an even surface.
3. Remove packing from stapling section and from under fold stop beneath the conveyor.
4. Lower output conveyor, allowing the slotted ends on the support bars (part no. 6.06) to locate on the protruding bolts provided. These bolts are located at the base of the machine.
5. When making books, one need only fit the conveyor wheels (part no.6.13) and make sure that the divert plate (part no. 3.71) shown in figure 2 is pushed forward.

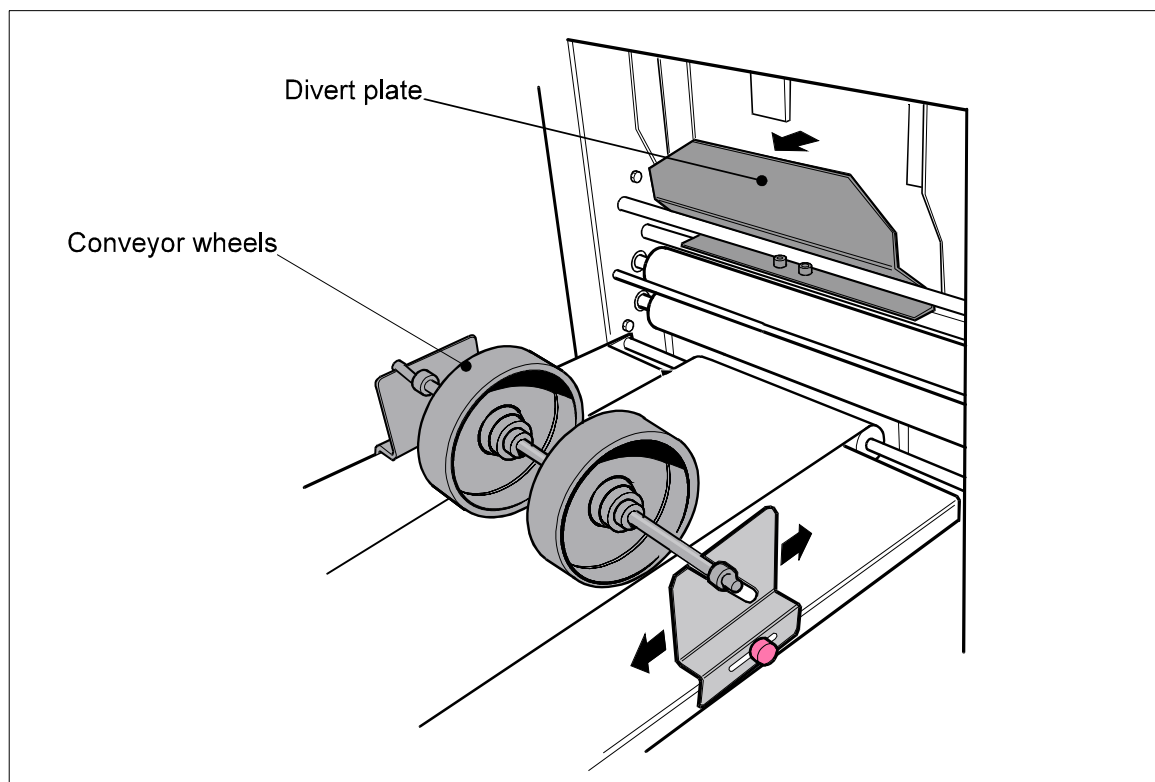

Figure 1 - Conveyor setup.

6. Insert the conveyor end stop (part no. 6.11) at the far end of the conveyor, making sure it does not infringe the belt. It is held in position by a flat magnet.
7. Position the machine near to a suitable socket outlet and ensure outlet is not covered and is easily accessible.
8. Check that the power supply is of the correct voltage for the machine. Once connected, the machine is ready for use.

4. OPERATION

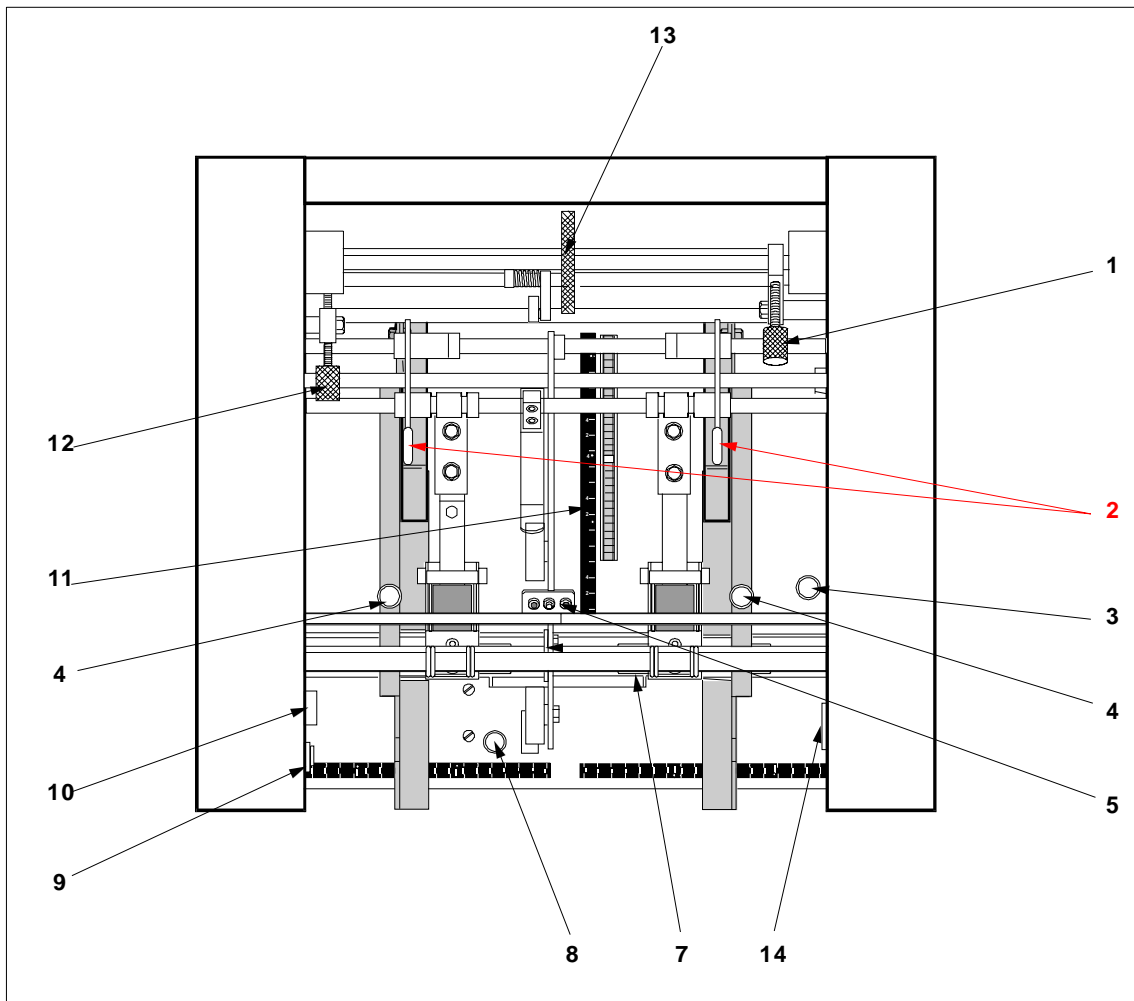

Figure 2 - Control layout

- | | | | |
|---|--------------------------------|----|---------------------------------------|
| 1 | Fold stop lock thumbscrew | 8 | Staple position fine adjustment screw |
| 2 | Stapling head position arm | 9 | On / off button |
| 3 | Edge staple stop thumbscrew | 10 | Staple delay knob |
| 4 | Side guide clamping thumbscrew | 11 | Staple/fold stop indicator |
| 5 | Staple low indicator / reset | 12 | Fold stop tilt adjustment thumbscrew |
| 6 | Anvil | 13 | Staple & fold stops adjustment wheel |
| 7 | Counter | 14 | Counter |

4.1 Loading Staples :

1. Only those staples sold or recommended by your supplier should be used in the Sprint 5000 Bookletmaker. Use of non recommended staples may damage the stapling heads and they are not covered by any warranty.
2. Raise the top cover.
3. Raise metal locking bar upwards and remove spent cartridge. Ensure the bar is in the uppermost position otherwise the cartridge may not load properly.
4. Make sure that staples do not protrude past the staple tear line. If necessary the staples are easily torn off at the tear line by tearing downward.
5. Cartridge should be placed flat on the slide in the body of the stapler and pushed firmly forward. Do not allow the cartridge to move backwards once inserted into the stapler. If this occurs remove cartridge from stapler and tear off staples at tear line again before re-inserting.
6. To keep the cartridge in place push metal locking bar down until it snaps into the groove on the back of the cartridge.
7. Press staple out reset button, lower top cover.
8. The staples do not immediately feed through to the plunger and therefore the machine will not staple during the first three or four cycles after loading. Where this is a problem, refer to 9 and 10 below.
9. Turn off staple out detector (select the centre position on the three-way toggle switch, see 4.2)
10. To avoid books being processed without staples, cycle the machine by placing scrap paper beneath the heads. Repeat this until staples appear in the paper.
11. Turn on staple out detector and continue producing books.

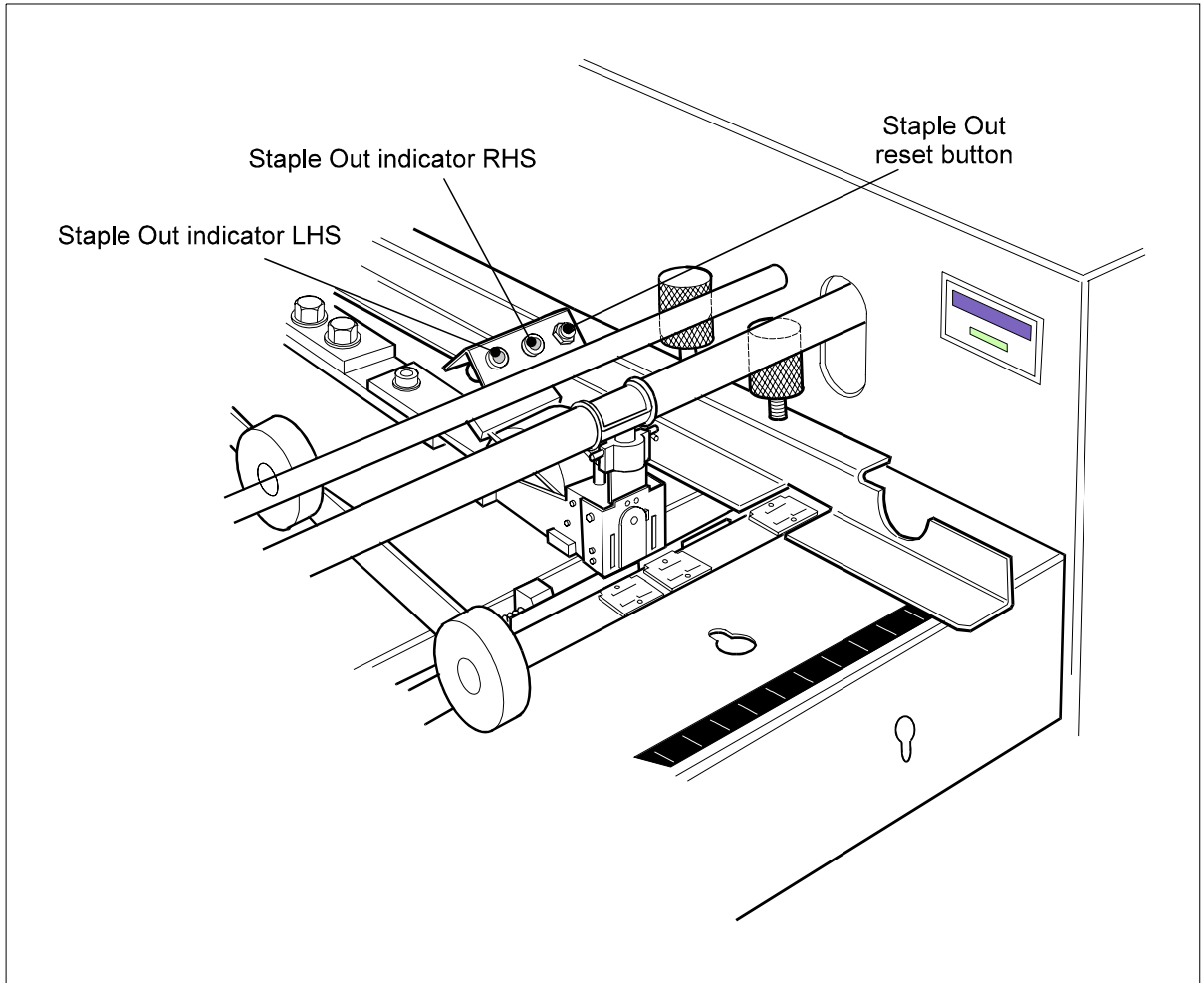

Figure 3 - Staple Out reset/indicators.

4.2 Staple Out System :

This is switched on and off using a three-way toggle switch located on the inside left-hand side wall underneath the shelf. Select the switch position as follows.

1. With the toggle switch is in the central position the staple out detectors on both heads are off.
2. With the toggle switch pushed downwards both staple detectors are on.
3. When the toggle switch is pushed to it's furthest position upwards only the staple out detector on the right-hand head is on (corner stapling).

The above is displayed on the legend plate around the switch (shown in figure 8.).

When the stapling head runs out of staples the red light pertaining to that head will illuminate and the booklet maker will not cycle. The last set will not be stapled and should be removed from the fold section. It can be reprocessed once the staple head(s) has been refilled.

4.3 Staple Jam :

To clear jammed staples from heads, it is best to remove the cartridge, clear any damaged staples from stapling head and anvil, and replace the cartridge as described in 4.1.

WARNING - One may clear the jammed staples by operating the plunger manually. In this instance take care not to put fingers under front-most portion of stapling head, so avoiding injury to fingers from staples being ejected from the head.

4.4 Paper Width Settings:

1. Both sides guides should be adjusted for a given size of paper. Loosen the thumbscrews and move the side guides until their outside edges are level with the marking on the scale corresponding to the width of the paper, and then re-tighten the thumbscrews so that the guides are held in place.

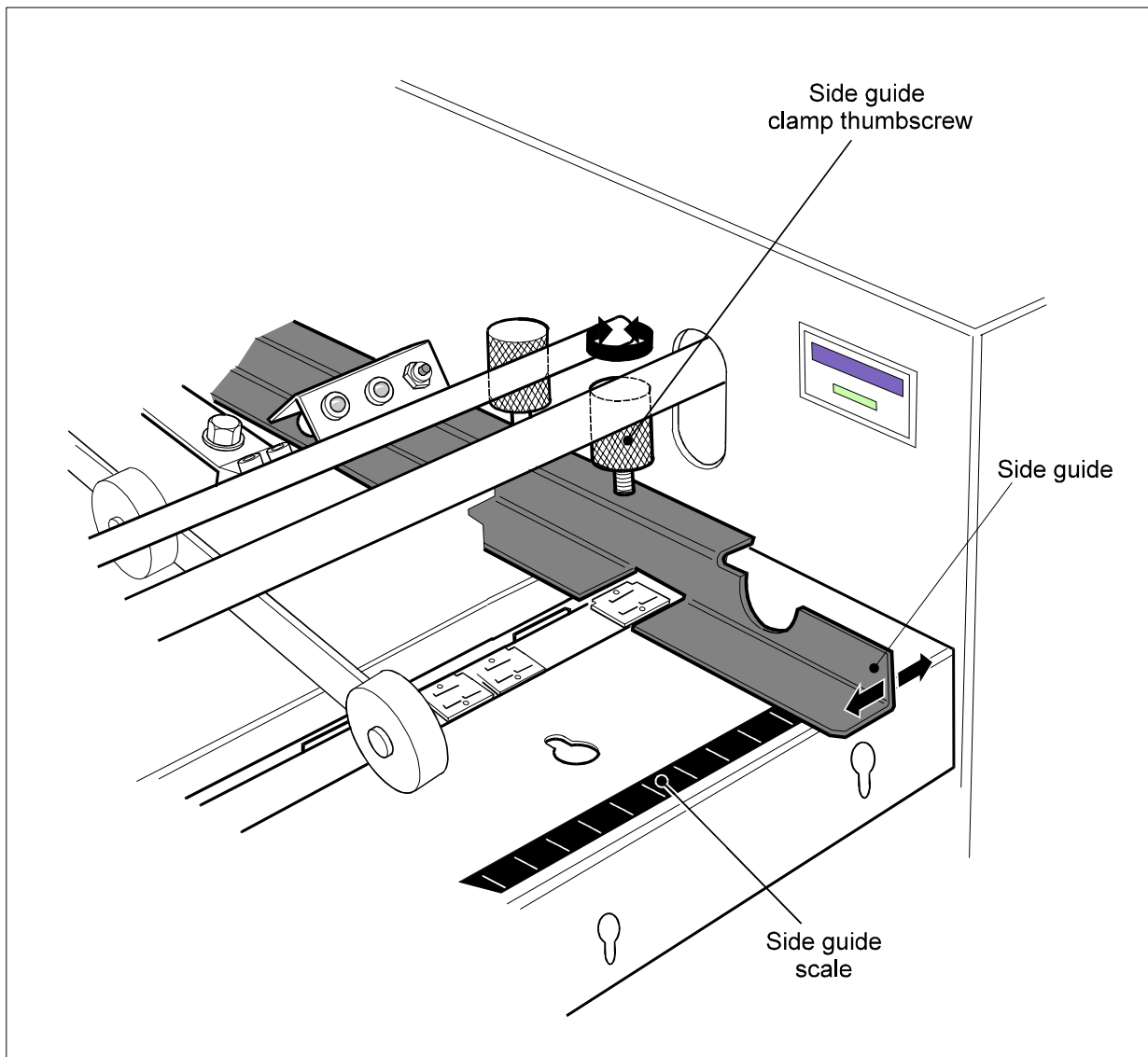

Figure 4 - Side guides.

2. Note that the marked settings are meant to be wider than the paper, to allow for side jog. Both guides move inwards on each cycle to the correct width to ensure that the sheets are aligned before stapling occurs.
3. When corner and edge stapling 8½" x 11" paper, feeding landscape, the guides are set to the 11" x 17" markings.

4.5 Stapling / Folding Positions :

1. The Stapling and the Folding positions are adjusted as one. Loosen fold stop lock thumbscrew, figure 5.
2. Turn the fold stop adjustment wheel until the staple stop aligns with the appropriate calibration on the scale, for the size of paper being used.

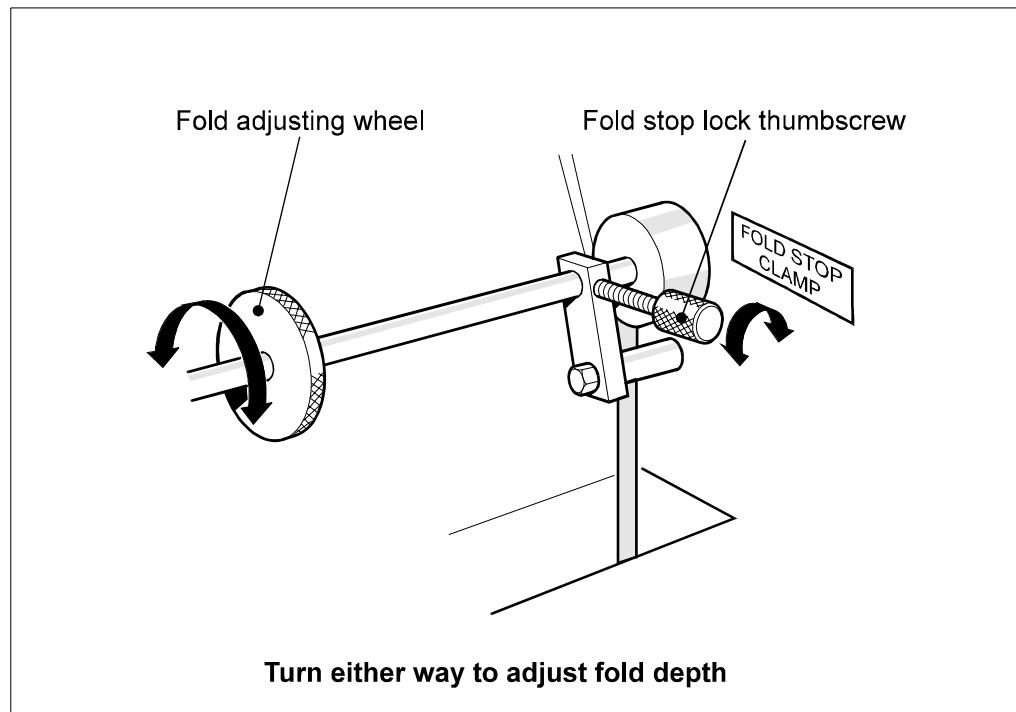

Figure 5 - Fold stop

3. Re-tighten fold stop lock thumbscrew when the stop has been correctly positioned.

4. If fold line is not perpendicular to booklet edges, this can be corrected by adjusting the fold stop tilt thumbscrew, figure 6, on the left-hand side of the fold stop adjusting shaft. Loosen the locking nut and turn the thumbscrew clockwise to raise the left-hand end of the fold stop, or anti-clockwise to lower. Tighten locking nut.

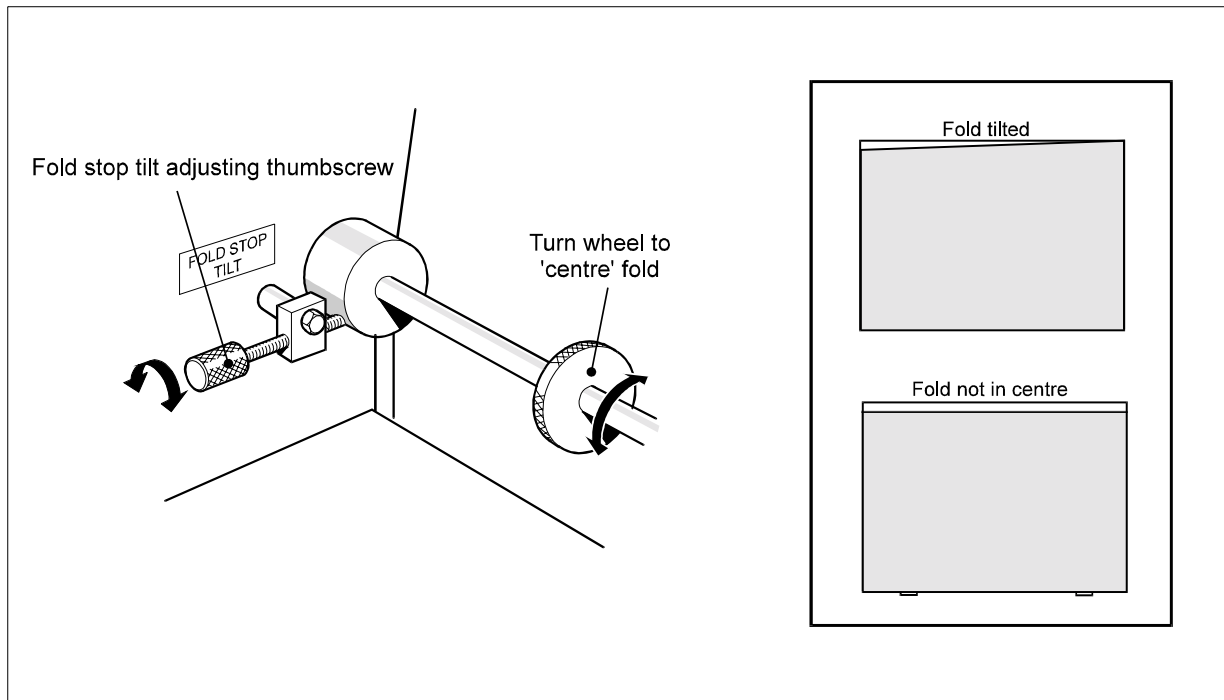

Figure 6 - Fold stop tilt.

4.6 Changing stapling head positions.

1. To move the stapling heads to the alternative positions, lift the stapling head position arm, figure 7, then slide the entire stapling unit to the new position.
2. When moving the stapling head, hold the slide bracket at the retaining plate end, and move to new position.
3. Drop the position arm into the new slot on slide bracket, which will align the stapling head in the new position.

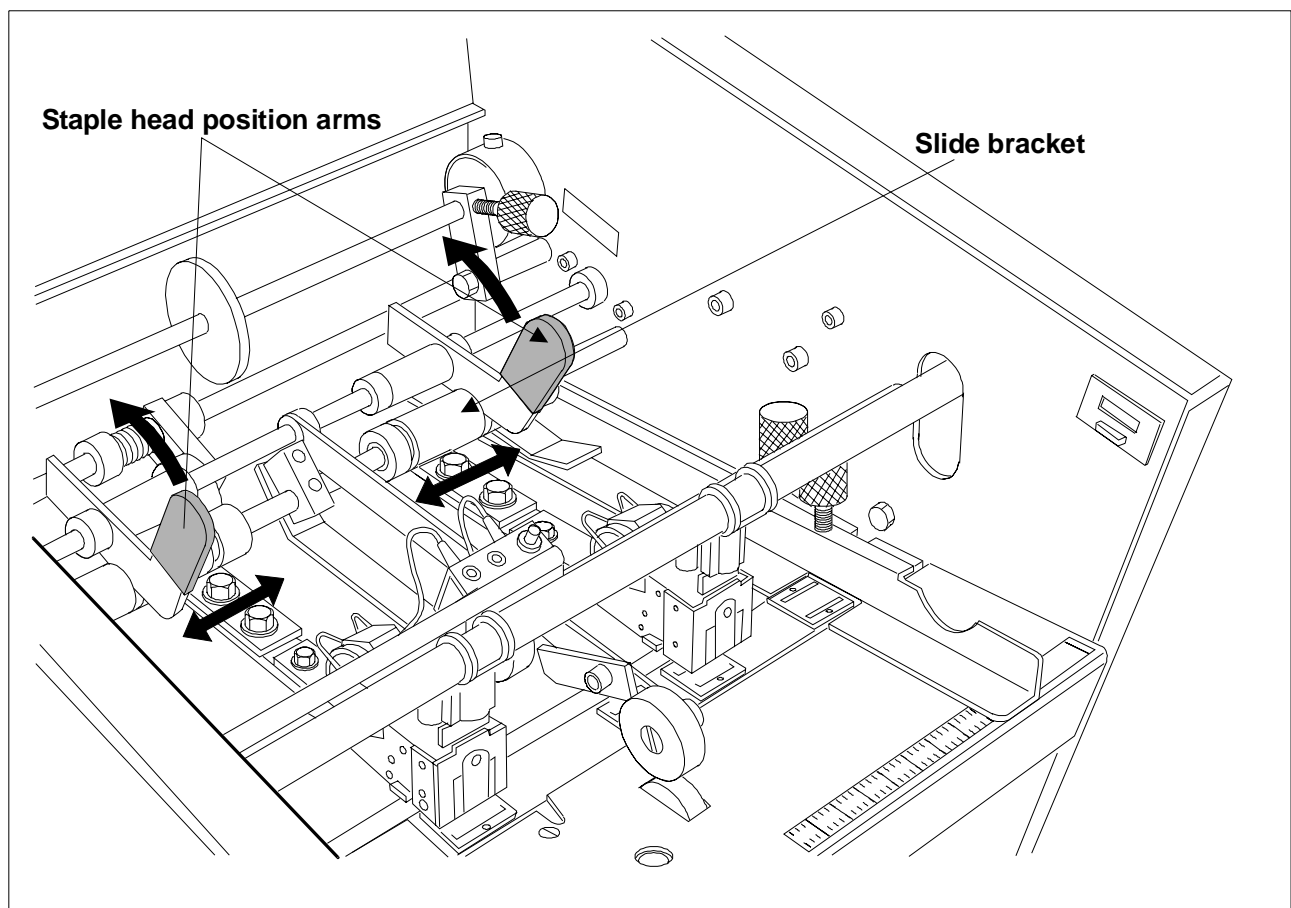

Figure 7 - Stapling head adjustment and anvil positions

4. Positions are provided for the various sized books between 4" x 5½" and 8½" x 11" paper, with an additional position on the far right for corner stapling 8½" x 11".

5. BOOKLET MAKING.

1. The machine will not operate with the top safety cover in the raised position. After closing the top safety cover it is necessary to press the circuit reset button, located in the left hand inside side wall. This is an added safety feature and the machine will not cycle until the button is pressed.

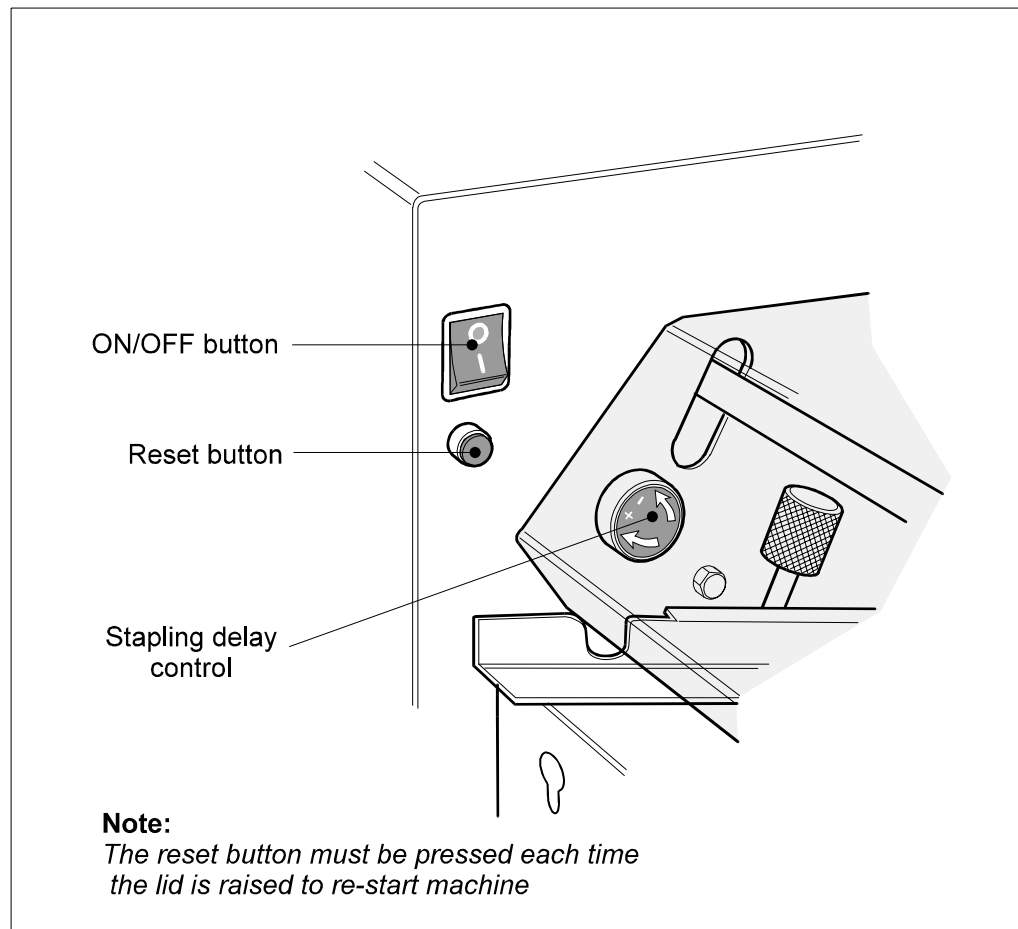

Figure 8 - Operating controls

2. When the machine is switched on the motor will not start until the first set of paper is placed in the machine. If it is left running and not used for a period of more than three minutes the motor will automatically switch off. The motor will re-start when paper is placed in the machine.
3. The stapling / folding operation is started when sensors detect the paper in the machine. The time between the paper entering the machine and the stapling action can be varied. This is achieved by turning the Stapling Delay Control shown in figure 8 clockwise for more time and anti-clockwise for less. When first using the machine, give the Stapling Delay Control a quarter turn clockwise. This will give time for the operator to settle the paper between the guides before the machine cycles.

4. When paper is placed in the machine it breaks the light beam between the photocell emitter (part no. 2.83) and the photocell receiver (part no. 2.71). On the interruption of the beam the time set by the timer expires and the machine will operate for one cycle.
5. If the stapled set fails to drop into the folding position the guides may be set too closely and must be set slightly wider. The first set placed in the machine will not fold and exit to the conveyor until the second set is being stapled. To release the last set from the machine, hold a scrap of paper under the stapling heads for one cycle and then remove it.
6. The conveyor wheels shown in figure 11 should be adjusted so that the wheels are just over a book's distance from the fold rollers. Too close and they will interfere with subsequent booklets coming out of the fold rollers. If the wheels are too far away the booklets will have the tendency to insert themselves inside previously ejected booklets.
7. Staple Position Fine Adjustment. If, after correctly setting the fold stop adjustment wheel, it is found that the staples are not exactly on the fold line, this can be corrected by turning the staple position fine adjustment screw, figure 9.

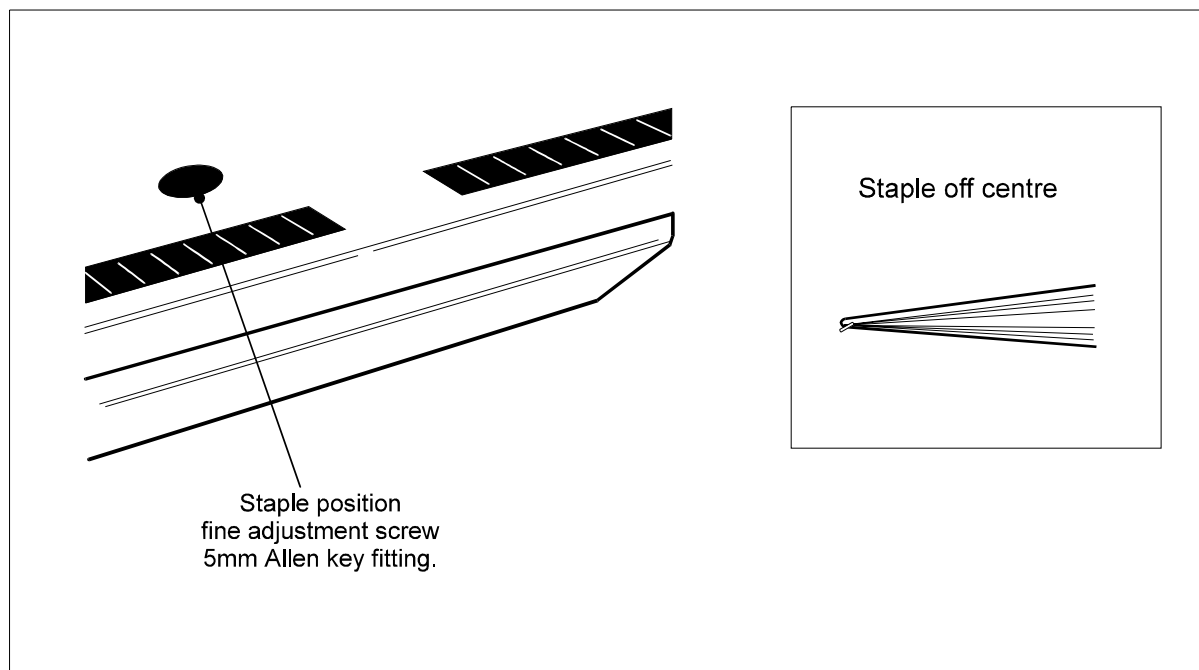

Figure 9 - Staple position fine adjustment

Looking at the finished booklets laying on the stacker table after ejection from the fold rollers, if the staples are visible above the fold, turn adjusting screw anti-clockwise. If the staples are below the fold, turn adjusting screw clockwise.

6. CORNER AND EDGE STAPLING

Refer to figure 10.

1. Open the top perspex cover. Move the paper width guides to the position where they will side jog the set of paper without impeding its path through the machine. For 8½" x 11" paper, set the guides to the 11" x 17" markings.
2. For edge stapling, select the desired pair of anvil positions. When corner stapling move the right hand stapling head to the furthest right position, and remove the staple cartridge from the left hand stapling head. Then move the left-hand stapling head and lock it down in position where it is not over an anvil. Alternatively one could also remove the left-hand stapling head as described in section 8 concerning replacing stapling heads.
3. Turn the corner/edge stop adjust thumbscrew, located in the second paper table shown in figure 10 to the right of the right-hand paper width guide, anti-clockwise. The stop will rise just behind the Anvil bar.

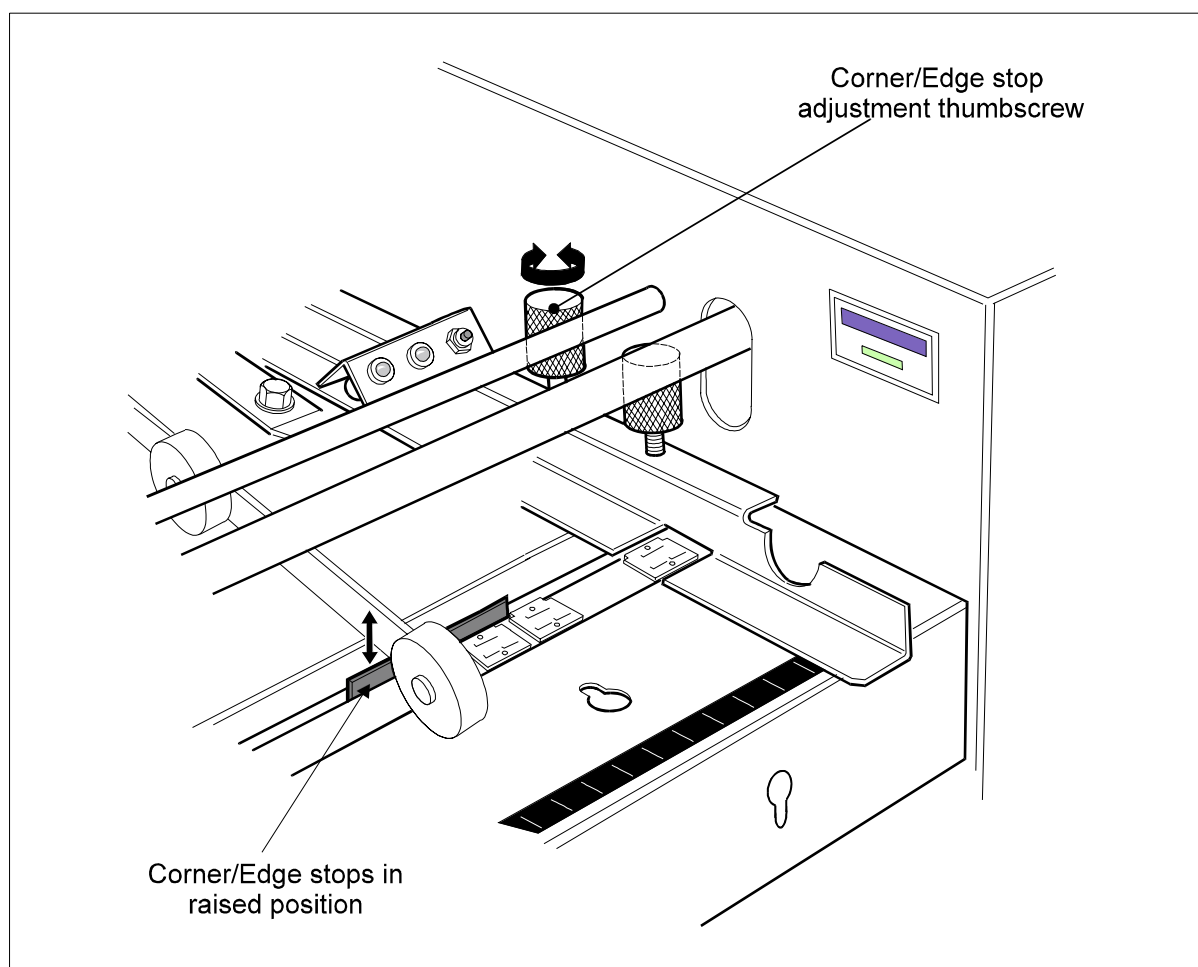

Figure 10 - Corner/Edge stops.

4. Push the divert plate (part no. 3.71) back against the Top front plate (part no. 3.42), figure 11. This will divert the set of paper away from the folding section and out of the machine.

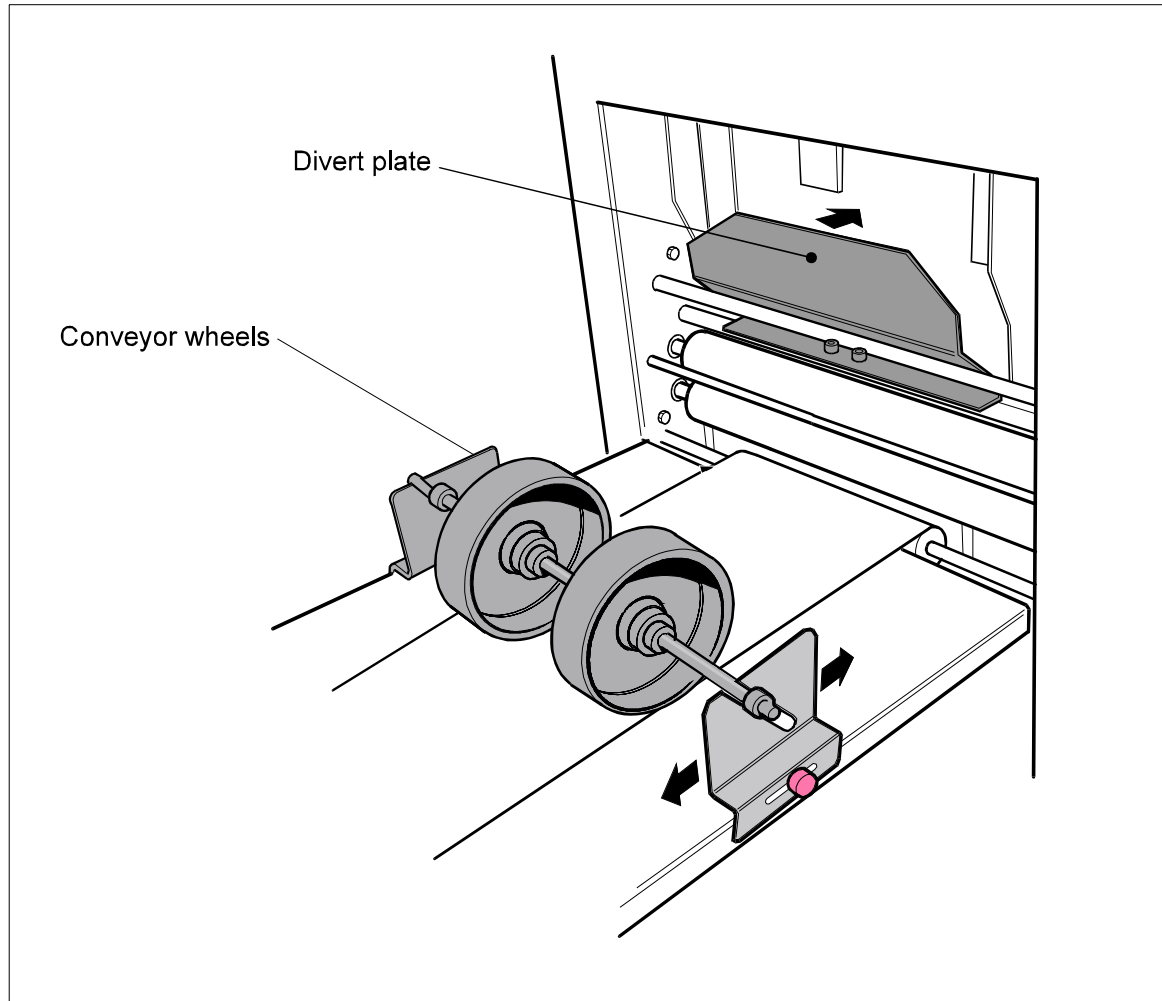

Figure 11 - Conveyor setup 1.

5. Fit the deflector plate, by fitting its hook over the tie bar, so that it rests on the outfeed conveyor.
6. Move the conveyor wheel support brackets which are held in place by thumbscrews, so that the edge nearest the main body of the machine is approximately 6" from the start of the conveyor. Figure 12 shows which way round they are fitted.

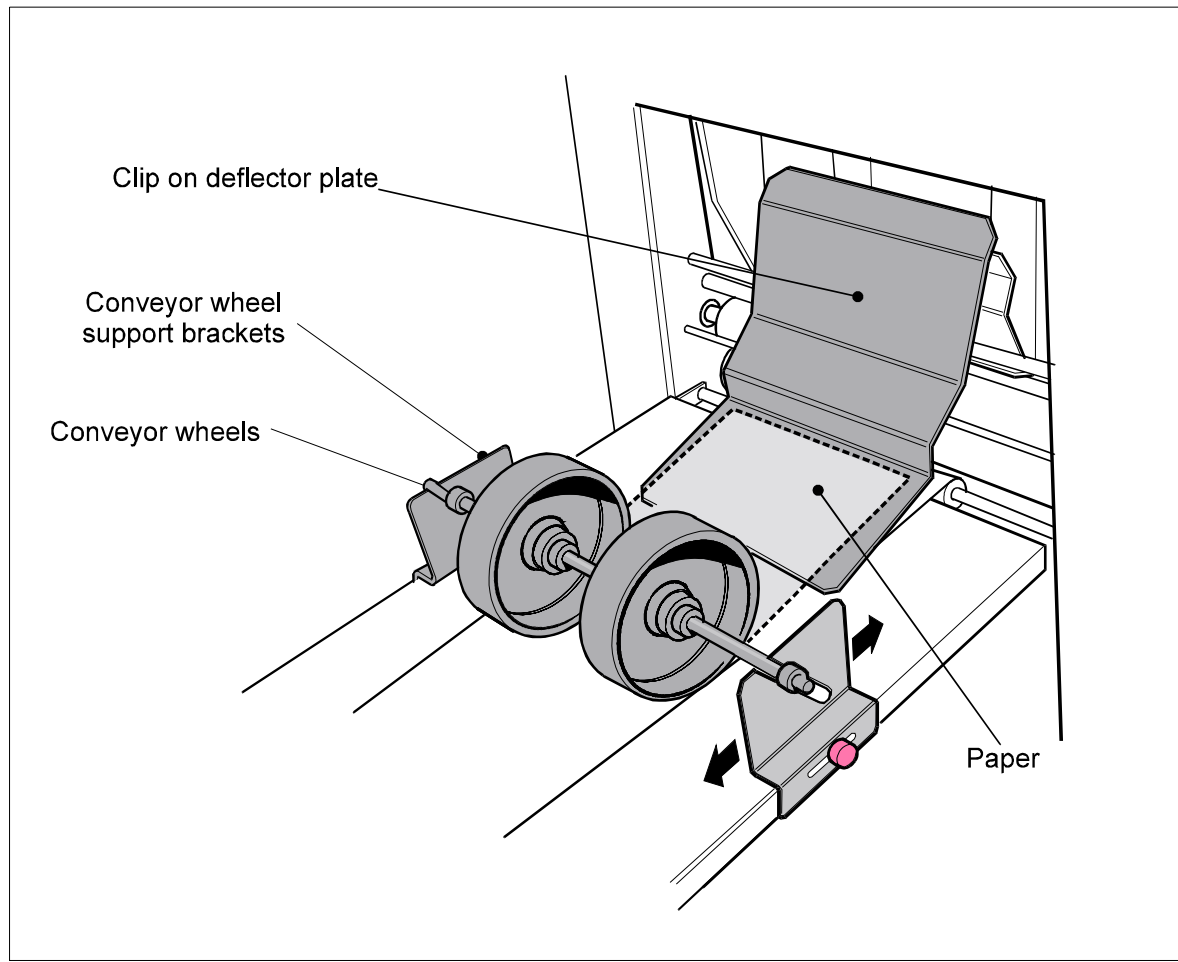

Figure 12 - Conveyor setup 2.

7. Place the conveyor wheel spindle (part no. 6.17) into the slots provided in the conveyor wheel support brackets.
8. As a set exits the machine down the Exit plate it should first come to a stop so that approximately 1" of the tailing edge is still resting on the raised upper portion of the Exit plate. During the next cycle that set will drop down to the next level avoiding the following set which will lay on top.
9. Ensure that the appropriate stapling head(s) is loaded, and the staple cartridge firmly pushed home. If staple out system is in use, press the staple out reset button. Close Perspex cover.
10. When hand feeding, insert the set to be stapled into the machine, underneath the stapling heads, until the leading edge touches the paper stops. The machine will cycle, when the sensors detect the paper, taking the set through the machine.
11. When on-line to a desk top collator, running 8½" x 11" paper, using a KAS conveyor/ jogger the link bracket should be fitted using the 11" x 17" bookletmaking slot. The back jogger should also be in the 11" x 17" position.

7. COUNTER

The counter can be reset to '0000' by pressing the rectangular black button below the number window.

8. REPLACING STAPLING HEADS

Should it become necessary to remove either or both of the stapling heads follow the procedure below.

1. Pull the left-hand side of the spring clip so that the eye clears the pin and swivel the spring clip anti-clockwise around the actuating bar. This should remove the hook on the right-hand side of the clip from the other end of the pin.
2. Unplug the electrical lead from the bracket containing the reset button and lights.
3. Loosen the small (M6) bolt in the stapling head retaining plate sufficiently so that the retaining plate can be lifted and pushed aside revealing the trough in which the bar at the back of the stapling head is located.
4. Take the bar from the trough and having removed the head completely replace the retaining plate in it's original position and tighten the bolt.
5. To re-fit a new head place the bar at the back of the stapling head into the trough, position the retaining plate over the top and tighten the bolt and replace the spring clip. Replace electrical lead.

9. ALIGNING OF STAPLING HEADS

Replacement stapling heads may be fitted to the Bookletmaker. If the replacement head is giving a bad staple, then remove power from the machine and re-align the head as below.

1. Remove cassette of staples from stapler.
2. Loosen the hex screws holding part no. 2.105
3. Place the adjustment guide between stapler and anvil.
Align and insert the raised lugs of the guide into the underside of the stapler where the staple exits, making sure the metal locating pip is to the front. When inserted replace the cassette of staples.

4. Locate pip on adjustment guide into small hole at front of anvil and then retighten hex screws. The stapling head should now be in a position to carry on stapling after removing adjustment guide.

10. PROBLEM SOLVING.

PROBLEM	POSSIBLE CAUSES	REMEDY
Motor will not start	Blown Fuse	Switch off and unplug machine. Check and replace fuses as necessary
Machine will not start when paper is inserted	Powerful light source from above	Shield safety cover from light or move machine
Machine will not cycle	Machine in jam mode	Remove paper from machine in stapling section to allow photo-cell to reset
Stapling head jammed	Incorrectly fitted staple cartridge	Switch off machine, lift safety cover, remove cartridge, clear jammed staples and replace.
Repeated jamming of stapling head.	Miss aligned head with anvil	Check alignment of stapling head and anvil.
Staple legs breaking.	Miss aligned head with anvil	Check alignment of stapling head and anvil.
One staple not on fold line	Fold stop out of line	Adjust tilt screw
Book does not travel through machine after stapling	Side guides too tight	Open right hand side guide
Pinching around staples	Residue being left on rollers	Clean rollers