

***Rhin-O-Tuff Onyx
PAL-14 Paks-A-Lift
Electric Paper Separator***

Instruction Manual



Provided by

MyBinding.com

When Image Matters.

Call Us at 1-800-944-4573

PAL-14 Piks-A-Lift Operator's Training Manual



Issue "0" 03/05

PDI Part # 900770

Performance Design Inc.
2350 East Braniff St.
Boise Idaho 83716

***This manual contains very important safety information
and must be read!***

PAL-14 Operator's Training Manual

Issue "0" 01/05

The PAL-14 paper separator will greatly increase productivity. An in-depth look at set up procedures is necessary to achieve maximum results.

The PAL-14 can attach to the OD-4000, OD-4012, OD-4800, HD-6500, HD-7000, or HD-7700 Performance Design Inc. punches and can also stand alone. The PAL-14 can also directly mount on top of Performance Design's APES-14 and APES-14-77. Paper sizes range from 5-1/2" x 5-1/2" (140mm) through 14" x 14" (356mm). A maximum of 6" (152mm) can be stacked at a time. This manual discusses all of the necessary steps to use and care for your machine.

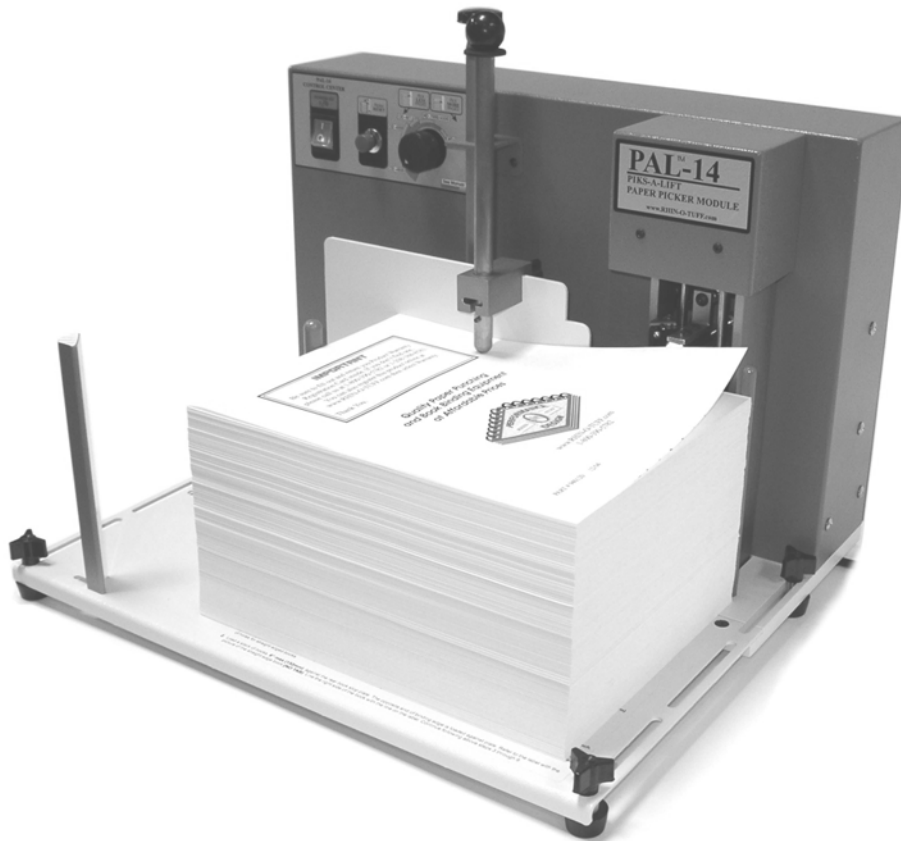

Table of Contents

Chapter:	Page Number:
1) Important safety notice!	4
2) Shipment Overview of the PAL-14	5
3) Assembly of PAL-14	6
4) Placing the PAL-14 in the proper location & Binding Styles	7
5) Mounting the PAL-14 onto the HD-6500, HD-7000 or HD-7700	7
6) Mounting the PAL-14 onto the OD-4012, OD-4000 or OD-4800	8
7) Mounting the PAL-14 onto an APES-14	9
8) Use as stand alone	10
9) Overview of your PAL-14 paper separator	10
➤ Power Switch.	
➤ Green Start Button.	
➤ Paper Amount, Adjustment Knob.	
➤ Book Stop Plate.	
➤ Tall Clamp Rod.	
➤ Left Book Stop assembly	
➤ Plunger Bracket	
➤ Sensor and Stabber	
➤ Reflector	
➤ Straight Edge Stop	
➤ Fuse Holder.	
10) Detailed Use of the PAL-14	11
➤ Powering up the PAL-14	
➤ Green Start Button	
➤ Book Stop Plate Adjustment Procedure.	
➤ Left Book Stop Rod Adjustment Procedure	
➤ Plunger Bracket	12
➤ Loading Paper	
➤ Paper Amount Adjustment Knob	13
11) Paper Separating and Punching.	13
12) Quick Setup Guide	14
13) Trouble Shooting	15
14) Schematics	16
15) Product Registration and Contact Information	17

Important Safety Notice!

Make sure you read this section very carefully! Learn to recognize this **Safety Alert Symbol**. The PAL-14 has been designed to provide a very high level of protection to an operator. Follow the guidelines below while installing, operating and maintaining your machine. Read this manual and keep for future use.



- Always replace fuses with the correct amperage and type:
 - ✓ 115VAC model use:
 - 2ea. #007120 FUSE, 2 AMP MDL SLO 1/4 X 1 1/4
 - 1ea. #001659 FUSE, 1.5 AMP GMA M5 X 20MM (circuit board)
 - ✓ 230VAC model use:
 - 2ea. #007019 FUSE, 1 AMP GDC SLOW M5 X 20
 - 1ea. #001659 FUSE, 1.5 AMP GMA M5 X 20MM (circuit board)

Refer to the serial number label on the rear of the machine to determine the voltage of your machine.

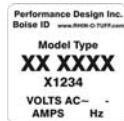

Serial Number Label Example.



- If the machine runs erratically while the machine is on, unplug the PAL-14 and call your dealer immediately for service.



- Never attempt to service your machine unless you are a qualified Technician. There are no user serviceable parts inside the PAL-14. **NEVER REMOVE BACK COVER! Doing so may result in personal injury!**



- Never operate the PAL-14 if the provided power cord does not fit your outlet. **Power cord shall be certified for the country where the machine will be installed.**

Shipment Overview of the PAL-14;

The very first step is to un-box the PAL-14 including the smaller accessory kit inside. Your PAL-14 requires some assembly before it can operate. Find an open area and layout the components inside the boxes as shown in illustration 2.0;

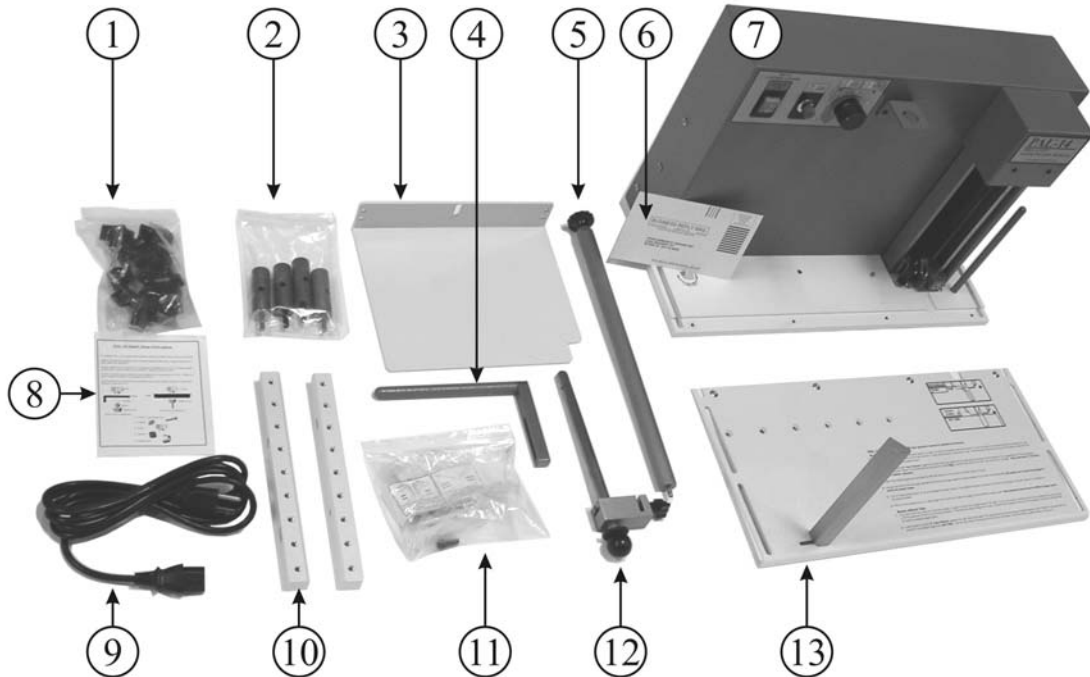

Illustration **2.0**

Listed below are the items in illustration 2.0. Please refer back to this list when the manual describes their use.

- 1) Knob, screw, washer, and spacer kit.
- 2) APES Module standoff kit.
- 3) Book Stop Plate, remove from standoffs on PAL-14 subassembly.
- 4) Left Book Stop assembly.
- 5) Tall Clamp Rod.
- 6) Warranty Registration Card, Please fill this out immediately and mail in.
- 7) Main PAL-14 subassembly.
- 8) Information sheet for PAL-14 stand-alone assembly.
- 9) Power Cord (Boxed separately in Europe).
- 10) Mate Blocks, used in mounting with HD-7000 and HD-7700 punches.
- 11) OD Bracket Kit, used in mounting with OD-4012, OD-4000, and OD-4800 punches.
- 12) Plunger Bracket.
- 13) PAL-14 Table.

Some of these items will not be required depending on your mounting style. Later in the manual we will describe the many mounting options for your PAL-14 including using the stand-alone option. When you have chosen your mounting option store the extra components for future use.

Assembly of PAL-14: See illustration 3.0

Some assembly is required before using the PAL-14.

- ✓ Locate the PAL-14 table (1), table attachment screws (2) and Allen key (3). Using the screws provided, attach the table to the main machine assembly (4) as shown.
- ✓ Attach the left book stop assembly (5) using the three winged knob (6). This can be installed at several different locations depending on the length of the book. This will be covered later in this manual.
- ✓ Attach the Book Stop Plate (7) on the two dowel studs with the short flange (8) facing toward the rear of the machine. The Book Stop has two possible locations, use the forward position for now, use of locations will be covered later in the manual. Use the Tall Clamp Knob (9) to secure plate in place as shown.
- ✓ Attach the plunger bracket (10) to the book stop plate (7). The location of this is not important at the moment. This will be covered later in this manual.

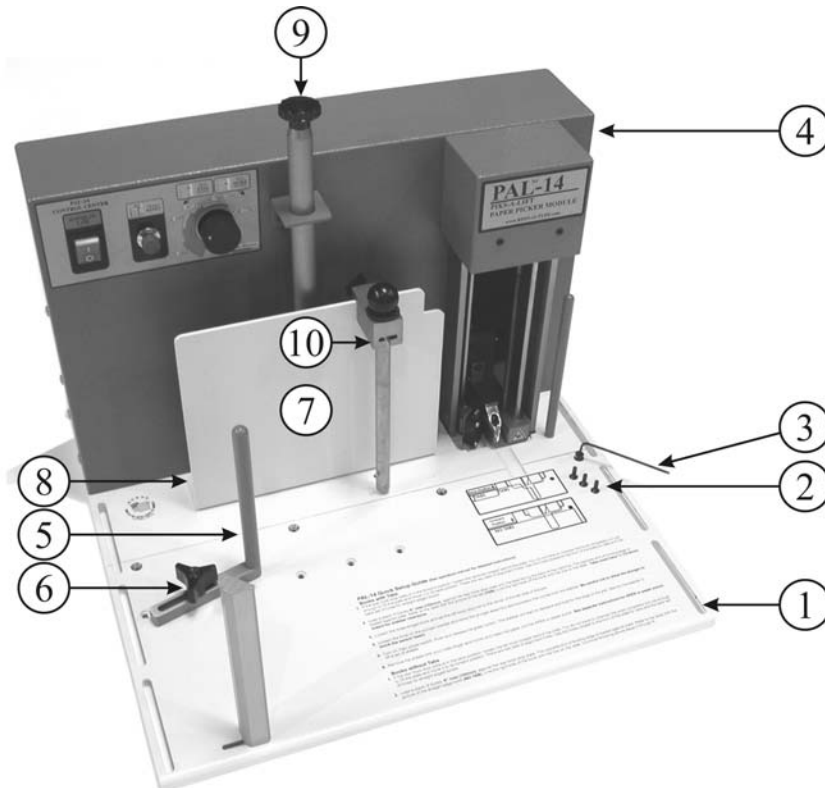

Illustration **3.0**

CHAPTER 4

Placing the PAL-14 in the proper location & Binding Styles;

Locate a clear work area with an outlet within 5 feet that provides a 15-amp service (16-amp European) which is protected at the customer's circuit box. The work area must be a solid, firm cabinet or a heavy duty table with a flat level surface. **Power cord shall be certified for the country where the machine will be installed.**

Placing your PAL-14 in the proper location will also depend on your punching technique. If you like to stand while punching, mount the PAL-14 on top of your punch machine or Performance Design's APES-14 or APES-14-77. If you want to punch paper while seated, and the PAL-14 is attached to the APES-14, you may notice an inconvenience while trying to pick paper and load it into the APES-14 paper slot while the previous loaded paper is exiting. It may be best to use the PAL-14 as a stand alone unit. The best location when using the PAL-14 in this mode would be to the right of the APES-14 and punch. The next chapters will cover all the optional mountings. Review all of them, pick and follow one then continue to Chapter 9; Overview of the PAL-14 Paper Separator.

CHAPTER 5

Mounting the PAL-14 onto the HD-6500, HD-7000 or HD-7700;

Locate the Mate Blocks, 1 ¼" long ¼"-20 socket head screws, and Allen wrenches provided inside the shipping kit as shown to the right.

These will be required in the next step.



ALWAYS USE TWO PEOPLE TO MOVE AN ELECTRIC PUNCH!



HD-6500 and HD-7000 Instructions;

See Illustration 5.1 on next page. Locate the two top-most and rear-most screws on the side of your HD-6500/7000. Inserting the short end of the Allen wrench into the screw head, remove the two screws.

HD-7700 Instructions;

See Illustration 5.2 on next page. Locate the two top-most and forward-most screws on the side of your HD-7700. Inserting the short end of the Allen wrench into the screw head, remove the two screws.

Both HD-6500/7000 and HD-7700 Instructions cont...

Store the two screws removed from the punch. Locate one of the Interface Blocks and orient it against the two now-available holes. Orient the block so that the interface block oval hole (1) is forward and the counter bores face out. To the right is an example of a counter bore. Use the 1 ¼" long ¼"-20 socket head screws provided to secure the block to the machine with the short end of the Allen wrench. Tighten the rear screw first then the forward screw. Repeat this step on the other side of your punch with the other block.

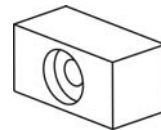

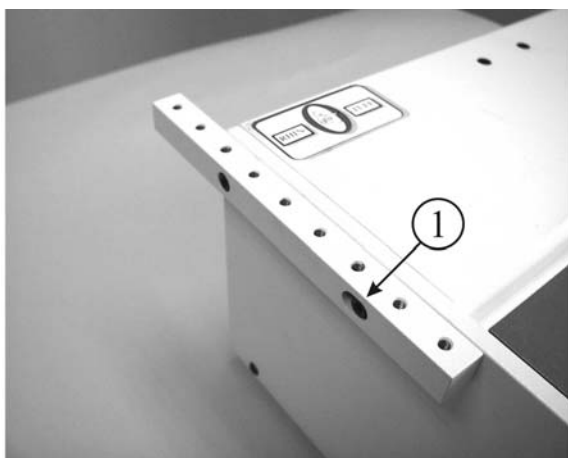

Illustration **5.1**

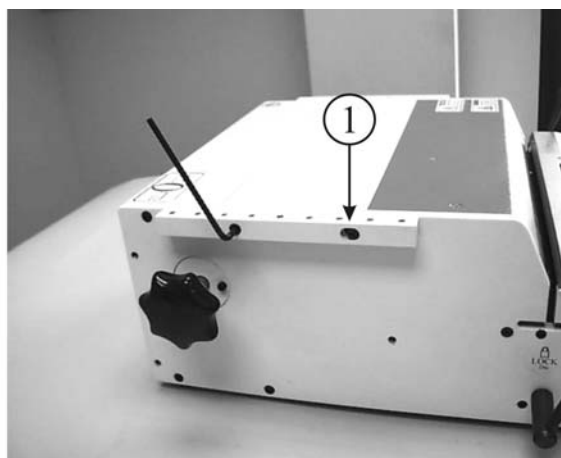

Illustration **5.2**

Place your PAL-14 on top of your punch, as shown in illustration 5.3. Use a white spacers (1) under the forward sheet metal portion of the table as shown, then use the 3-winged knobs to fasten the PAL-14 to your punch as shown. Repeat on opposite side of your PAL-14. Only three knobs are actually required, the knob that is located on the machine forward and right may be removed if there is interference with the paper stack.

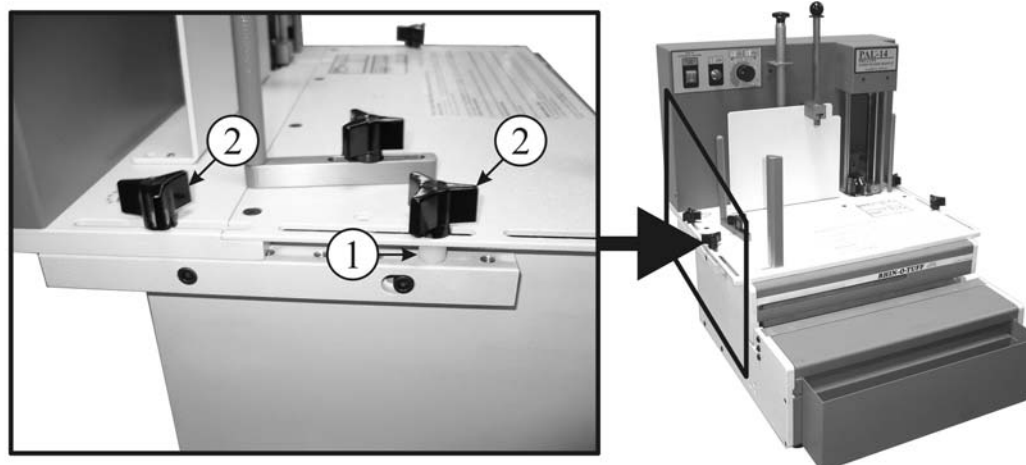

Illustration **5.3**

CHAPTER **6**

Mounting the PAL-14 onto the OD-4000, OD-4012 or OD-4800:

See illustration 6.0.

Locate the OD hardware kit included with the PAL-14. The kit includes the following parts; Two OD brackets (1) (left hand & right hand), four mounting screws, and an Allen wrench. Attach the brackets as shown using the screws and wrench, place your PAL-14 on top of the OD punch and secure with the two 3-winged knobs. The (OD-4800 users: Most likely you will never find a need for mounting the PAL-14 on an OD-4800 but it is possible. Call the factory at 1-800 390-5782, ask for technical support, and make sure you have the most recent model punch or a shaft extension upgrade will be required for the OD-4800).

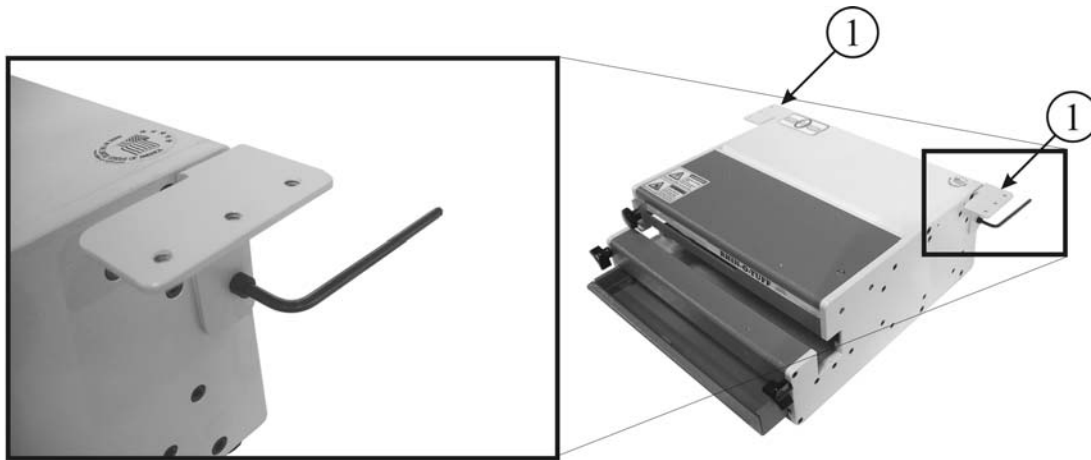

Illustration **6.0**

CHAPTER 7

Mounting the PAL-14 onto an APES-14:

See illustration 7.0.

Make sure the APES is mounted on the HD punch before proceeding with this step, refer to the APES manual.

Locate the APES module standoff kit. Remove the four long metal spacers (1) and find the two short plastic spacers (2). The position of these standoffs will be determined by the slots located on the APES base plate. There is no exact location for these standoffs or which slots are used. Use the 3-winged knobs (3) to secure the PAL-14 to the APES. The operator can choose a comfortable working distance for the PAL-14 by choosing different mounting positions. The long spacers will be used toward the rear of the PAL-14 base plate. There is a threaded shaft protruding from one end of the long spacer. Insert this threaded shaft through the slot of the APES, and screw it into the interface blocks previously mounted on the HD punch. Use the same procedure for the front two spacers except this time, insert the threaded shaft through the plastic washer first, and then through the slots of the PAL-14. Only three knobs are actually required, the knob that is located on the machine forward and right may be removed if there is interference with the paper stack.

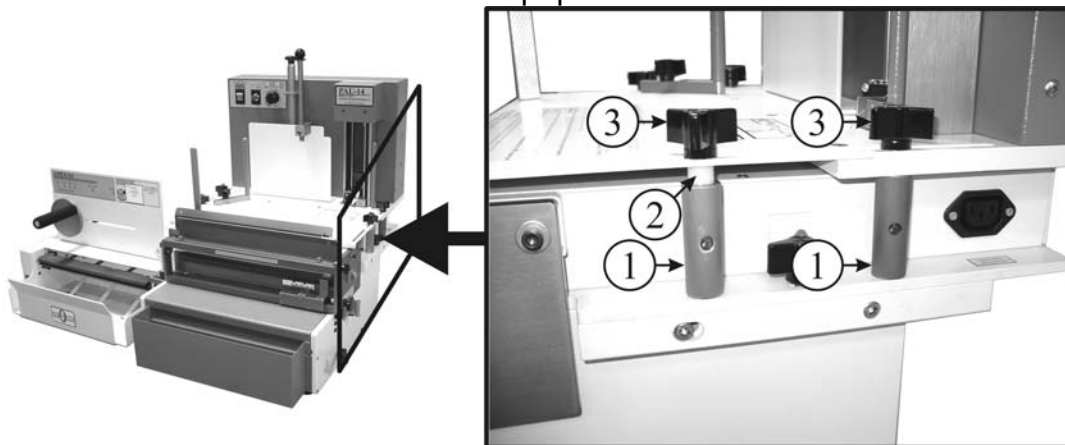

Illustration **7.0**

CHAPTER 8

Use as stand alone:

Locate the Information sheet for PAL-14 stand-alone assembly. Follow the instructions.

CHAPTER 9

Overview of the PAL-14 Paper Separator:

See illustration 9.0.

The PAL-14 has many useful features to increase your punching productivity.

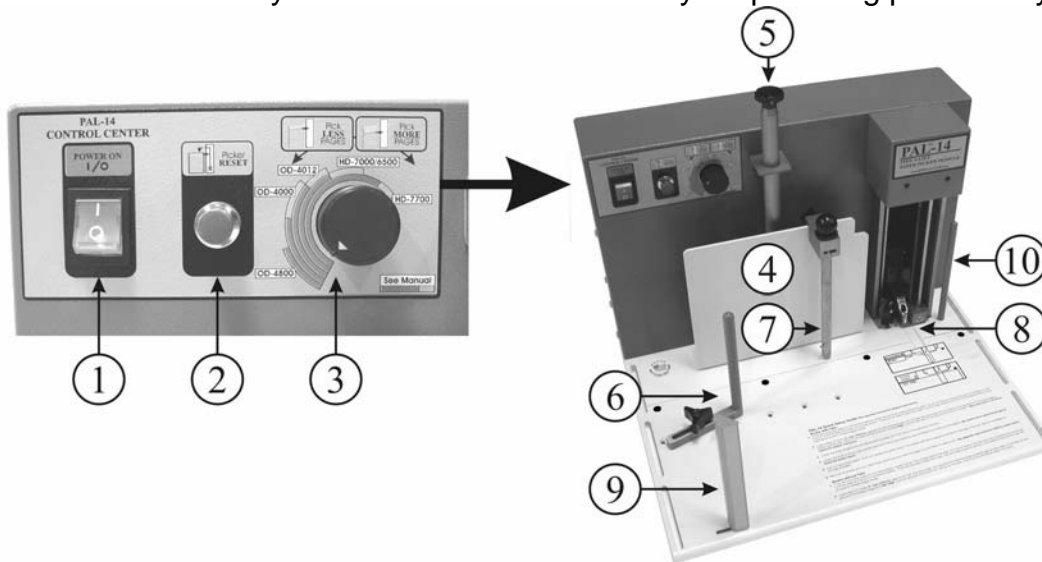

Illustration 9.0



1. **Power Switch:** This switch turns on the main power to the PAL-14. **In case of any emergency use the power cord as the main power cutoff!**
2. **Green Button:** Press this button to start the picking process. It is also used to reset the stabber to the pile more quickly so you do not have to wait for it to travel to its top position.
3. **Paper Amount Adjustment Knob:** Use this knob to adjust the number of sheets to be separated. This adjustment should be determined by the type of die being used and the type of machine.
4. **Book Stop Plate:** The Book Stop plate will need to be adjusted when changing a job from tabs to straight edge binding or vice versa.
5. **Tall Clamp Knob:** Allows 2-position movement of the Book Stop Plate.
6. **Left Book Stop assembly:** The Book Stop Rod acts as a left hand book stop for different length paper.
7. **Plunger Bracket:** The plunger will prevent the sheets being lifted from moving forward. Only use the plunger rod if the paper is being pushed forward as the stabber is entering the pile of paper.
8. **Sensor and Stabber:** Detects and picks paper. Never adjust sensor!
9. **Reflector:** Works with the sensor to detect paper.
10. **Straight Edge Stop:** Assists in aligning non-tabbed paper.
11. **Fuse Holder:** Not Shown, located on the rear of machine. Always replace fuses with the correct amperage and type.

- ✓ 115VAC use:
 - 2ea. #007120 FUSE, 2 AMP MDL SLO 1/4 X 1 1/4
 - 1ea. #001659 FUSE, 1.5 AMP GMA M5 X 20MM (circuit board)
- ✓ 230VAC use:
 - 2ea. #007019 FUSE, 1 AMP GDC SLOW M5 X 20
 - 1ea. #001659 FUSE, 1.5 AMP GMA M5 X 20MM (circuit board)

CHAPTER 10

Detailed Use of the PAL-14 Paper Separator:

See illustration 9.0 on previous page.

1. Powering up the PAL-14:

Make sure the PAL-14 is plugged into a wall outlet. Press the main switch to turn the machine on. The stabber assembly may move to its uppermost position if not already there.

2. Green Start Button:

Press this button to start the picking process. It is also used to reset the stabber to the pile more quickly so you do not have to wait for it to travel to its top position. You can push this button anytime the paper stabber needs to be reset. **The Stabber will reset to the back position after several minutes. If no paper is removed when this happens you will need to push the green reset button again.**

3. Book Stop Plate Adjustment Procedure:

There are two possible adjustment positions for this plate. All the way toward the back of the machine which is for tabs and all the way forward for straight edge books.

Books with Tabs

If the rear book stop plate is in the forward position, loosen the tall clamp knob located behind the plate. You do not have to unscrew the tall clamp knob completely but just enough to lift the plate and move it to its back position. There are two sets of alignment holes. Use the holes closest to the front of the plate for tabs and the back set of holes for straight edged books.

Books without Tabs

If the rear book stop plate is in the back position, loosen the tall clamp knob located behind the plate. You do not have to unscrew tall clamp knob completely but just enough to lift the plate and move it to its forward position. There are two sets of alignment holes. Use the holes closest to the front of the plate for tabs and the back set of holes for straight edged books.

4. Left Book Stop Rod Adjustment Procedure: See illustration 10.0.

The left book stop rod is used to position the pile laterally so the stabber enters the pile of paper in the proper location. Use the reference labels located next to the stabber for the proper location of the pile, Use the right position for straight edged books and the left position for book with tabs. *Tabs*

must have a 1/2" (12.5mm) indent so stabber enters pile correctly. **Be careful not to allow the left stop rod (1) to block sensor beam (2).**

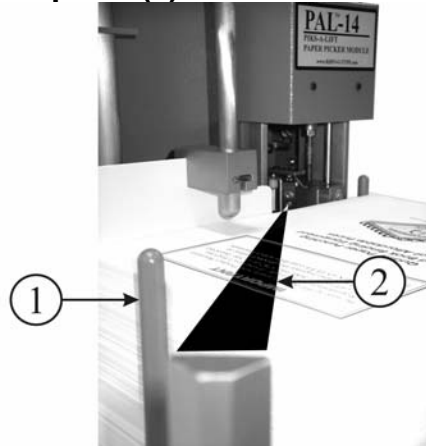

Illustration **10.0**

5. **Plunger Bracket:** See illustration 10.1.

The plunger is used to add weight to the top of the pile. The only time it will be necessary to use this is when a lift of paper slides forward as the stabber enters the pile. Occasionally a lift of paper will slide forward as it enters the pile even with the plunger on the paper. This usually happens when heavy cover stock is being separated. This is normal. The lift that pushed forward of the pile will be equal to the amount which would have been lifted. Insert this into the punch or APES as you would normally do. **Be careful not to allow plunger (1) to block sensor beam (2), the machine will not pick paper.**

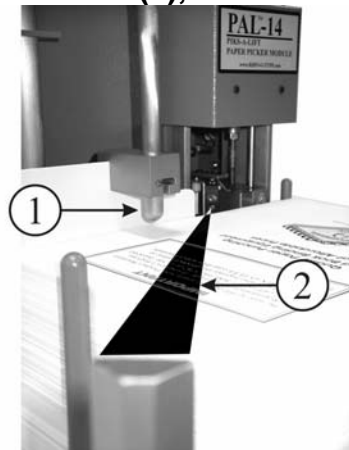

Illustration **10.1**

6. **Loading Paper:**

Load up to 6" of paper with the top of the book facing the rear of the machine. If tabs are being separated, jog the book on the binding edge and place the tabs against the book stop plate. Try not to let the stack of paper and tabs become misaligned as you place the stack in position.

7. **Paper Amount Adjustment Knob:**

Set the adjustment knob clockwise to increase the number of sheets and counterclockwise to decrease the number of sheets. Depending on the model punch and type of die being used, this amount will vary. Use a comfortable setting so the sheets fit into the die without much effort. The Green area is the normal setting for narrow mouth dies, the yellow indicated the wider mouth dies such as 3-Hole, VELO™_{GBC}, and Comb. The PAL-14 is not a paper counter. The amount of paper can vary a small amount. This is usually do to the paper relaxing which causes the pile to grow in height or the pile compressing as the stabber enters which causes the pile to shrink. Normally, it will vary only by a few sheets so unless you have the amount setting to high, the paper will enter the die with no problem.

CHAPTER

1 1

Paper Separating and Punching:

The PAL-14 has been designed to save time by always having a predetermined amount of paper lifted from the pile, and ready for an operator to insert either into a paper punch or the APES-14 attachment. Set the paper adjustment knob so the stabber lifts an amount of paper which comfortably fits into the die slot. The machine and type of die being used will determine how much paper can be picked. The label should only be used as a reference.

PAL-14 Quick Setup Guide:**Books with Tabs**

1. If the rear book stop plate is in the forward position, loosen the tall knob located behind the plate. You do not have to unscrew this knob completely but just enough to lift the plate and move it to its back position. There are two sets of alignment holes. Use the holes closest to the front of the plate for tabs and the back set of holes for straight edged books.
2. Load a stack of books, **6" max (152mm)**, against the rear book stop plate with the tabs facing the back of the machine. The opposite end of the binding edge is loaded against plate. Refer to the label with the picture of the tab (**TAB**). Line the right side of the book with the line on the label. **Tabs must have ½" (12.5mm) indent for stabber clearance.**
3. Loosen the three winged knob and set the left book stop rod to the center of the left side of the pile.
4. Loosen the knob on the plunger bracket and move the plunger assembly approximately five inches from the stabber. **Be careful not to allow the left stop rod to block sensor beam.**
5. Turn on main power switch. Push and release the green button. The stabber will start to descend and look for the edge of the pile. Wait for the stabber to lift a set of sheets.
6. Remove the sheets with your index finger and thumb and insert into the APES or paper punch. **See separate instructions for APES or paper punch.**

Books without Tabs

1. If the rear book stop plate is in the back position, loosen the tall knob located behind the plate. You do not have to unscrew this knob completely but just enough to lift the guide and move it to its forward position. There are two sets of alignment holes. Use the holes closest to the front of the plate for tabs and the back set of holes for straight edged books.
2. Load a stack of books, **6" max (152mm)**, against the rear book stop plate. The opposite end of binding edge is loaded against plate. Refer to the label with the picture of the straight edge book (**NO TAB**). Line the right side of the book with the line on the label. Continue following above steps 3 through 6.



Trouble Shooting;
Only qualified personnel should attempt to work on this equipment!

Most of the problems you may encounter are due to setup problems. There are two fuses on the 115VAC machine and two fuses on the 230VAC machine located on the rear of the PAL-14 that can be replaced by the customer. Below is a troubleshooting guide to help you through most of the problems that may be encountered.

Trouble Shooting

Symptom	Possible Cause	Action
Stabber assembly does not move up or down when green button is pushed. (Main power switch lamp not illuminated)	1) Machine is off. Switch is in down position with light off. 2) Machine is not plugged in. 3) Blown fuse.	1) Place switch in up position with light illuminated. 2) Check both ends of the power cord. 3) Check fuse. See Chapter 1 for fuse listing.
Stabber goes to very top and stays after a reset.	1) Plunger is mounted to far right. 2) Left book stop is positioned between sensor and reflector.	1) Re-adjust plunger to the left. 2) Re-adjust left book stop to the left.
Stabber moves back and is not picking paper.	1) Stabber timed-out after a few minutes.	1) This is normal. Push the reset button to continue job.
Stabber stays pushed out or is jammed inward.	1) Stabber may have been bumped.	1) If this continues contact your dealer immediately.

CHAPTER 14

Schematics;

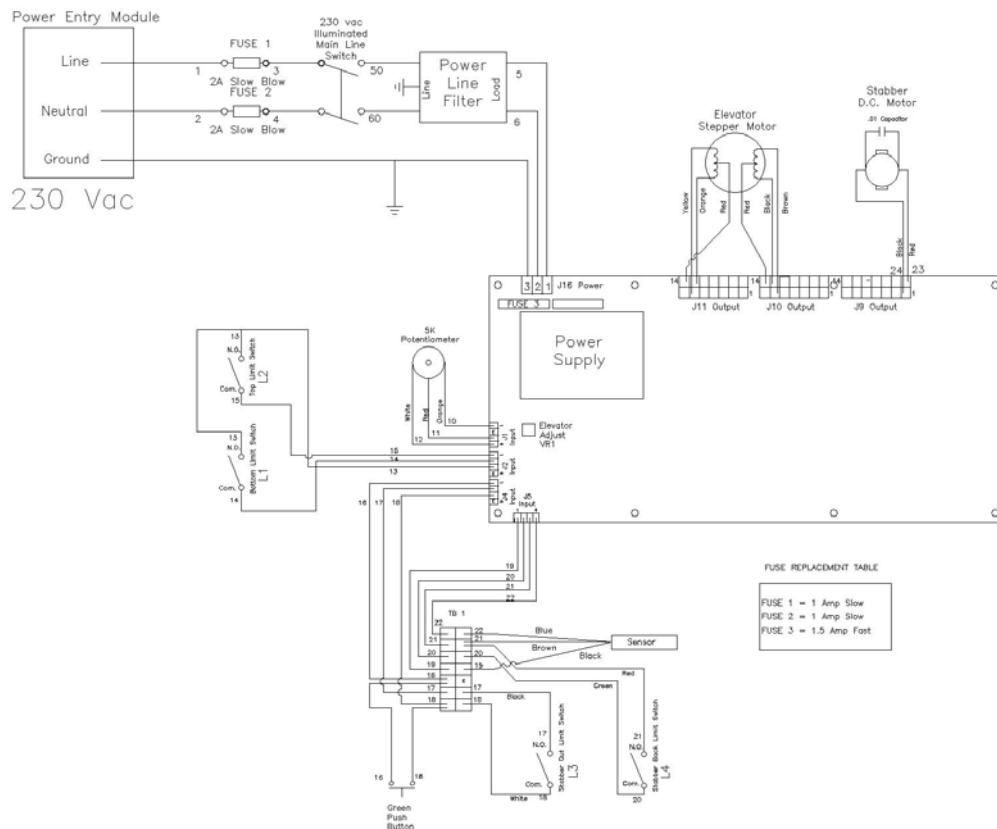
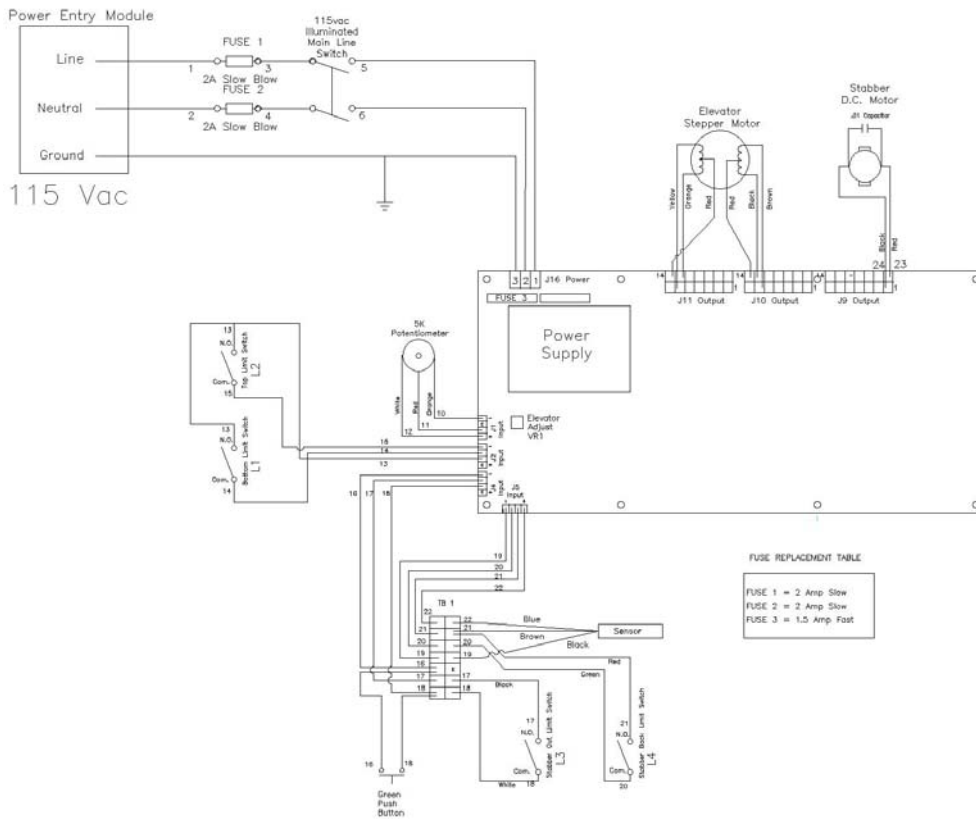

CHAPTER 15

Product Registration and Contact Information;

Product registration is important to establish trouble free warranty repair of any of your Rhin-O-Tuff equipment. Please fill out and mail in the card provided with your machine or register on-line at www.RHIN-O-TUFF.com then select Warranty.

For repair, service, supplies, or any other help, contact your dealer.