

Standard PS-P61 Punch Stapler

Parts Manual



Provided By

MyBinding.com®
When Image Matters.

PARTS BOOK



PS-P61

とじ機
Punch Stapler

Horizon

This page is intentionally left blank.



PS-P61 Revision Control List

Correction (a: Parts No. · c: Description · d: S/N · e: Remarks · f: Other · g: Registration · h: Illustration · i: Qty · j: Delete)

Book No.	Date	Bulletin Code	S/N applied	Fig.	Ind.	Correction	Before	After	Remarks
UB701015-03	Jan/31/2002			10	1	a	NO510	4009362-00	
	Jan/31/2002			10	10	h			
	Jan/31/2002			10	11	h			
	Jan/31/2002			11	18	a	A803217-00	26C-AM-5-Y195	
	Jan/31/2002			13	29	a	L001824-00	4011278-00	
	Jan/31/2002			13	29	a	L001825-00	4011279-00	
	Jan/31/2002			13	29	a	L001826-00	4011280-00	
	Jan/31/2002			14	2	a	M021894-00	M021894-01	
	Jan/31/2002			14	9	a	4004546-00	4001438-00	
	Jan/31/2002			14	9	d		40001	S/N From
	Jan/31/2002			14	9	e		3mm	
	Jan/31/2002			14	9	f	9	10	Change index
	Jan/31/2002			14	10	e		4mm	
	Jan/31/2002			14	10	f	10	9	Change index
	Jan/31/2002			14	11	a	UM101023-00	UM101023-04	
	Jan/31/2002			14	11	a	UM201013-01	UM201013-04	
	Jan/31/2002			16	18	a	CSK-268-AP	4700005-00	
Jan/31/2002			16	19	a	ARM-075	4011971-00		
Jan/31/2002			16	20	a	CSD-2120-P	4700006-00		
UB701015-04	Dec/24/2002			2	9	a	M041523-11	M041523-12	
	Dec/24/2002			5	19	a	M041534-50	M041534-51	
	Dec/24/2002			7	9	d		036899	M021745-00
	Dec/24/2002			7	10	a	M041645-30	M041645-31	
	Dec/24/2002			7	13	a	M041555-00	M041555-01	
	Dec/24/2002			7	17	a	M041644-30	M041644-31	
	Dec/24/2002			7	18	d		036899	M021744-00
UB701015-05	Jly/23/2003			1	8	a	M041548-30	M041548-31	
				1	13	a	M041641-12	M041641-13	
				1	17	a	M041546-13	M041546-15	
				1	21	a	TL-71S	4011009-00	
				1	23	i	8	4	M001898-03
				2	3	a	TM-218-16	4006983-00	
				2	3	i	2	1	4006983-00
				2	6	d		051899	A803203-00
				2	6	g		A924605-01	
				3	7	a	M041501-23	M041501-26	
				3	11	a	M032257-10	M032257-11	
				3	12	a	M041550-00	M041550-03	
3	13	a	TL-99	4011008-00					

PS-P61 Revision Control List

Correction (a: Parts No. · c: Description · d: S/N · e: Remarks · f: Other · g: Registration · h: Illustration · i: Qty · j: Delete)

Book No.	Date	Bulletin Code	S/N applied	Fig.	Ind.	Correction	Before	After	Remarks
UB701015-05				3	14	a	M041672-00	M041672-01	
				3	16	d		051899	M041528-10
				3	20	d		-006917	M074809-00
				3	20	d		-007901	M074809-10
				4	4	a	M901254-30	M901254-31	
				4	5	a	M901250-30	M901250-31	
				4	7	a	M021749-00	M021749-10	COMPATIBLE
				4	8	i	3	1	M021776-00
				4	10	a	M041628-61	M041628-64	
				4	13	i	2	1	M041631-11
				4	16	a	M001897-02	M001898-03	
				4	19	a	M041630-20	M041630-21	
				4	42	d	006917	-006917	
				5	1	a	M041535-21	M041535-22	
				5	2	a	M041536-31	M041536-32	
				5	3	a	M041531-21	M041531-22	
				5	9	d	006917	-006917	M041684-10
				5	10	d	008917	-008917	M041532-40
			-051899	5	10	d		051899	M041532-51
			100001-	5	10	g		M041532-60	
				5	12	d	006917	-006917	M041659-40
				5	12	d	007901	-007901	M041659-41
				5	15	a	M041626-44	M041626-46	
			-051899	5	16	a	M041623-11	M041623-13	
			100001-	5	16	g		M041623-20	
			-051899	5	17	d		051899	M041529-10
				5	19	a	M041534-51	M041534-52	
				5	20	d	008917	-008917	M041530-60
				5	20	a	M041530-70	M041530-78	
				5	21	d	007901	-007901	M074823-01
				5	22	d	007901	-007901	M074826-00
				5	23	d	007901	-007901	M074824-10
				6	1	a	M041617-02	M041617-04	
			6	2	a	M041619-20	M041619-21		
			6	3	a	M041613-20	M041613-21		
			6	5	a	CBS0806615F	4011016-00		
			6	11	i	2	1	M021763-01	
			6	13	a	M041312-30	M041312-31		
			6	16	a	M041614-30	M041614-31		
			6	24	g		4007706-00		
			7		h				

PS-P61 Revision Control List

Correction (a: Parts No. · c: Description · d: S/N · e: Remarks · f: Other · g: Registration · h: Illustration · i: Qty · j: Delete)

Book No.	Date	Bulletin Code	S/N applied	Fig.	Ind.	Correction	Before	After	Remarks
UB701015-05			-051899	7	1	d		051899	STW-10
			-051899	7	3	d		051899	M041554-11
			-051899	7	4	d		051899	M900961-10
				7	5	d	008917	-008917	M041551-30
			001001-051899	7	5	d		051899	M041551-50
			-051899	7	6	d		051899	M041622-10
			-051899	7	7	d		051899	M041642-20
			-051899	7	8	d		051899	M041643-20
				7	10	d	008917	-008917	M041645-21
			-051899	7	10	d		051899	M041645-31
			001001-051899	7	11	d		051899	STW-8
			-051899	7	12	d		051899	M001897-02
			-051899	7	13	d		051899	M041555-01
			-051899	7	15	d		051899	M001844-02
			-051899	7	16	d		051899	M001954-02
				7	17	d	008917	-008917	M041644-21
			001001-051899	7	17	d		051899	M041644-31
				8	2	a	M041602-30	M041602-31	
				8	5	a	M041605-10	M041605-11	
				8	6	a	M041603-30	M041603-31	
				8	8	a	M041609-20	M041609-21	
				8	23	a	M041595-10	M041595-11	
				8	30	i	2	1	M021763-01
				8	38	a	M041616-00	M041616-01	
				8	42	g		4007706-00	
				9		h	←008917	-S/N-008917	
				9	1	a	D2D-2000	4011033-0	
				9	2	d	008917	-008917	M041581-10
				9	4	a	M041578-71	M041578-73	
				9	4	d	008917	-008917	M901151-22
				9	5	a	M041652-31	M041652-33	
			-051899	9	12	d		051899	M041696-01
			100001-	9	12	g		M041696-10	
			-051899	9	13	d		051899	M901142-12
			100001-	9	13	g		M901142-20	
			-051899	9	14	d		051899	A803212-00
			100001-	9	14	g		M087669-10	
				9	16	a	348XL037	4011327-00	
				10		h	←008917	-S/N-008917	
				10	3	d	008917	-008917	M041572-21
			10	3	a	M041572-23	M041572-25		

PS-P61 Revision Control List

Correction (a: Parts No. · c: Description · d: S/N · e: Remarks · f: Other · g: Registration · h: Illustration · i: Qty · j: Delete)

Book No.	Date	Bulletin Code	S/N applied	Fig.	Ind.	Correction	Before	After	Remarks
UB701015-05				10	4	d	008917	-008917	M041581-10
				10	6	a	M041575-40	M041575-42	
				10	7	a	M041571-41	M041571-43	
				10	9	a	M041574-30	M041574-31	
				10	10	d	008917	-008917	A983223-00
				11		h	008917	-008917	
				11	3	d	008917	-008917	M041662-00
				11	4	d	008917	-008917	98XL025
				11	5	d	008917	-008917	A803213-00
				11	6	d	008917	-008917	M901144-10
				11	7	d	008917	-008917	A803214-00
				11	8	d	008917	-008917	M041683-02
				11	9	d	008917	-008917	M041660-10
				11	10	d	008917	-008917	A803215-00
				11	11	d	008917	-008917	112-03-11
				11	12	d	008917	-008917	M041661-00
				11	13	d	008917	-008917	M900975-00
				11	14	d	008917	-008917	4005256-00
				11	15	d	008917	-008917	M900974-10
				11	16	d	008917	-008917	A803216-00
				11	17	d	008917	-008917	M041552-20
				11	18	d	008917	-008917	26C-AM-5-Y195
				12	12	a	LCA100S-24	4011029-00	
				12	12	a	LCA100W-24	4011030-00	
				12	13	a	4007693-00	4011267-00	
				12	13	a	LDA10F-51	4011268-00	
				12	16	a	418037	4006964-00	
				13	12	a	M041556-21	M041556-22	
				13	21	a	M041546-10	M041546-11	
				13	23	d	008917	-008917	M001790-06
				13	24	d	008917	-008917	M041675-00
				14	11	a	UM201013-04	UM201013	
				15	12	a	M041591-30	M041591-31	
			16		h				
			-051899	16	17	d	051899	M041552-30	
			-051899	16	19	d	051899	4011972-00	
			100001-	17	1	g	STW-12		
			100001-	17	2	g	4000912-00		
			100001-	17	3	g	M041554-20		
			100001-	17	4	g	M001852-04		
			100001-	17	5	g	M041551-70		

PS-P61 Revision Control List

Correction (a: Parts No. · c: Description · d: S/N · e: Remarks · f: Other · g: Registration · h: Illustration · i: Qty · j: Delete)

Book No.	Date	Bulletin Code	S/N applied	Fig.	Ind.	Correction	Before	After	Remarks
UB701015-05			100001-	17	6	g		M041622-20	
			100001-	17	7	g		M041642-30	
			100001-	17	8	g		M041643-30	
			100001-	17	9	g		M041555-01	
			100001-	17	10	g		M041606-00	
			100001-	17	11	g		M001870-01	
			100001-	17	12	g		M041644-31	
			100001-	17	13	g		4014380-00	
			100001-	17	14	g		M048800-01	
			100001-	17	15	g		M036652-02	
			100001-	17	16	g		M041552-40	
			100001-	17	17	g		4013890-00	
			100001-	17	18	g		M001790-06	
			100001-	17	19	g		4013376-00	
UB701015-06	Mar/19/2004		100001-	17	13	a	4014380-00	4014591-00	4014591-00
			100001-	17	13	e		96XL037	
			100001-	17	15	a	M036652-02	M041700-00	
UB701015-07	Oct.18.2007			2	6	a	A803203-00	A803203-01	
				2	6	d	051899		
				2	6	j	A924605-01		
				2	11	a	A803204-00	A803204-01	
			070307_AA	4	1	e	cm	mm	
			070307_AA	4	2	e	cm	mm	
			070307_AA	4	3	e	cm	mm	
			070307_AA	4	4	e	cm	mm	
			070307_AA	4	5	e	cm	mm	
			070307_AA	4	6	e	cm	mm	
			070307_AA	4	7	i	3	2	
			070307_AA	4	8	i	1	2	
			070307_AA	4	12	i	2	4	
			070307_AA	4	13	i	1	2	
			070307_AA	4	14	e		Inch	
			070307_AA	4	15	e		Inch	
			070307_AA	4	16	i	1	2	
			070307_AA	4	37	e		mm	
			070307_AA	4	38	e	cm	mm	
			070307_AA	4	39	e	cm	mm	
070307_AA	4	41	e	cm	mm				
070307_AA	4	43	g		M072326-02				
006687			14	6	a	4007736-00	4011011-10		

PS-P61 Revision Control List

Correction (a: Parts No. · c: Description · d: S/N · e: Remarks · f: Other · g: Registration · h: Illustration · i: Qty · j: Delete)

Book No.	Date	Bulletin Code	S/N applied	Fig.	Ind.	Correction	Before	After	Remarks
UB701015-08	Apl.8.2008	CD080018_00	-138899	2	5	d		138899	M041513-01
		CD080018_00	139001-	2	5	g		M041513-10	
		CD080018_00	139001-	2	15	g		UD4-10	
		CD080018_00	-138899	3	17	d		138899	M041514-30
		CD080018_00	139001-	3	17	g		M041514-40	
		CD080018_00	139001-	3	22	g		UD4-10	
UB701015-09	Aug.12.2008	DW080522_00		4	20	a	M900979-10	M172951-00	
		DW080522_00		4	25	a	M900980-10	M172952-00	
		DW080522_00		4	29	a	M9000982-00	M172953-00	
		DW080522_00		4	30	a	M900983-00	M172954-00	
		DW080522_00		4	31	a	M900971-00	M172950-00	
		DW080522_00		9	26	a	M901152-10	M172956-00	
				12	18	a	M901303-00	M074821-00	
				14	1	a	M901253-10	A983225-00	
		DW080409_50		17	14	a	M048800-01	M048800-02	
		DW080409_50		17	14	e		@	M048800-02

Important Information

This parts book is designed to help you to have easy access to a part or parts you need. Whenever you need to locate a part or parts of the machine involved in repair, service or for some other reason, please use this Parts Book as a guide source reference.

When ordering a part or parts, please be sure to give us the following parts information.

1. Model Name
2. Machine Serial Number
3. Fig. No.
4. Index No.
5. Parts No.
6. Quantity

(Example)

<u>Model</u>	<u>S/N</u>	<u>Fig.No.</u>	<u>Ind.No.</u>	<u>Parts No.</u>	<u>Qty</u>
ABC-12	001001	1	3	M009999-99	2

In the Remark column, additional information is provided with abbreviation style. Please check the Remark column to find necessary parts.

(Abbreviation)

IND.1-10	Assembled parts using parts through Ind.1 to 10
S/N From	Parts applied to machines from stated S/N
S/N To	Parts applied to machines up to stated S/N
400V	Only for 400V Machine
230V	Only for 230V Machine
220V	Only for 220V Machine
200V	Only for 200V Machine
115V	Only for 115V Machine
100V	Only for 100V Machine
mm	Only for mm Version
inch	Only for inch Version
Compatible	Compatible with Mxxxxxx-xx



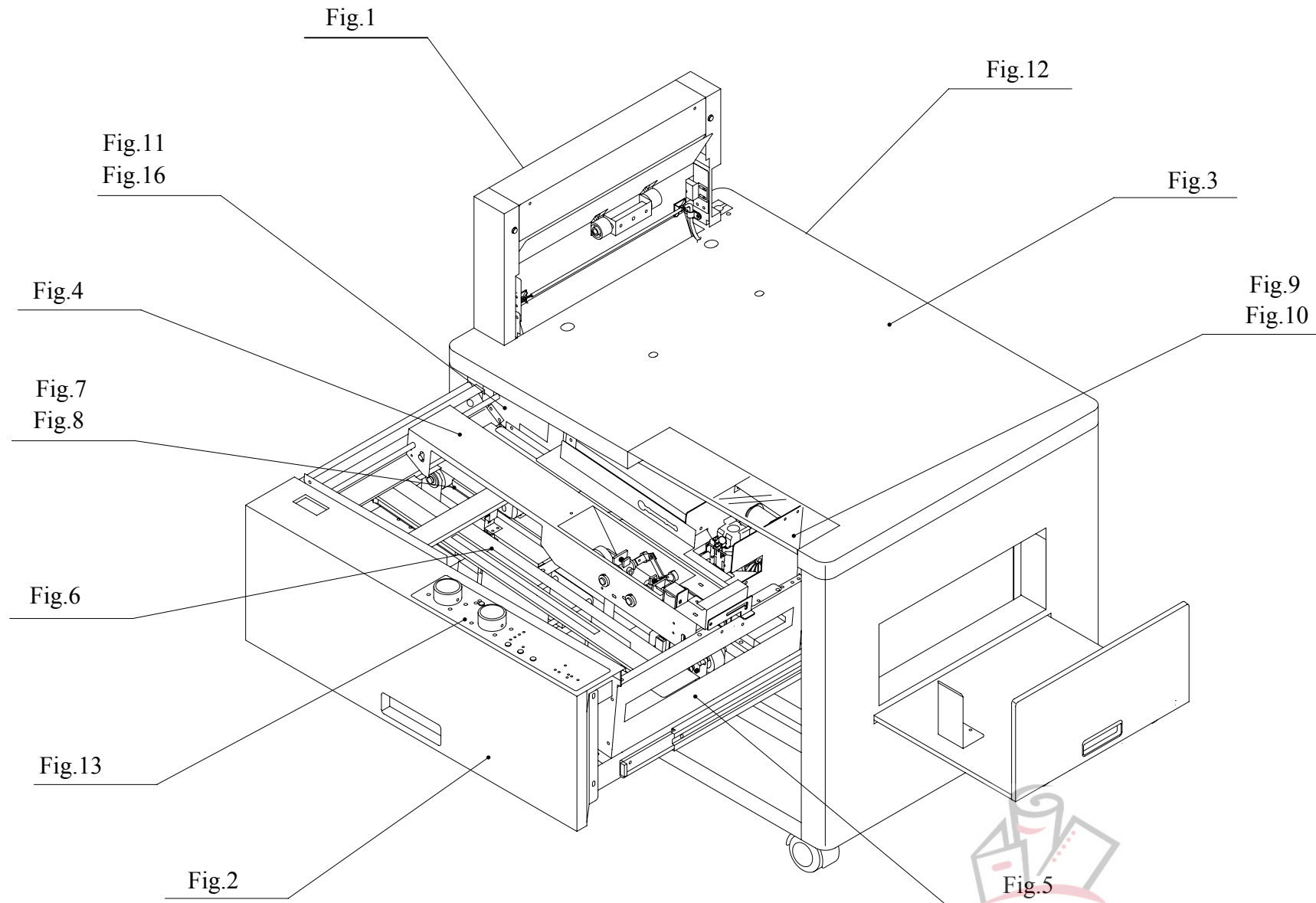

This page is intentionally left blank.



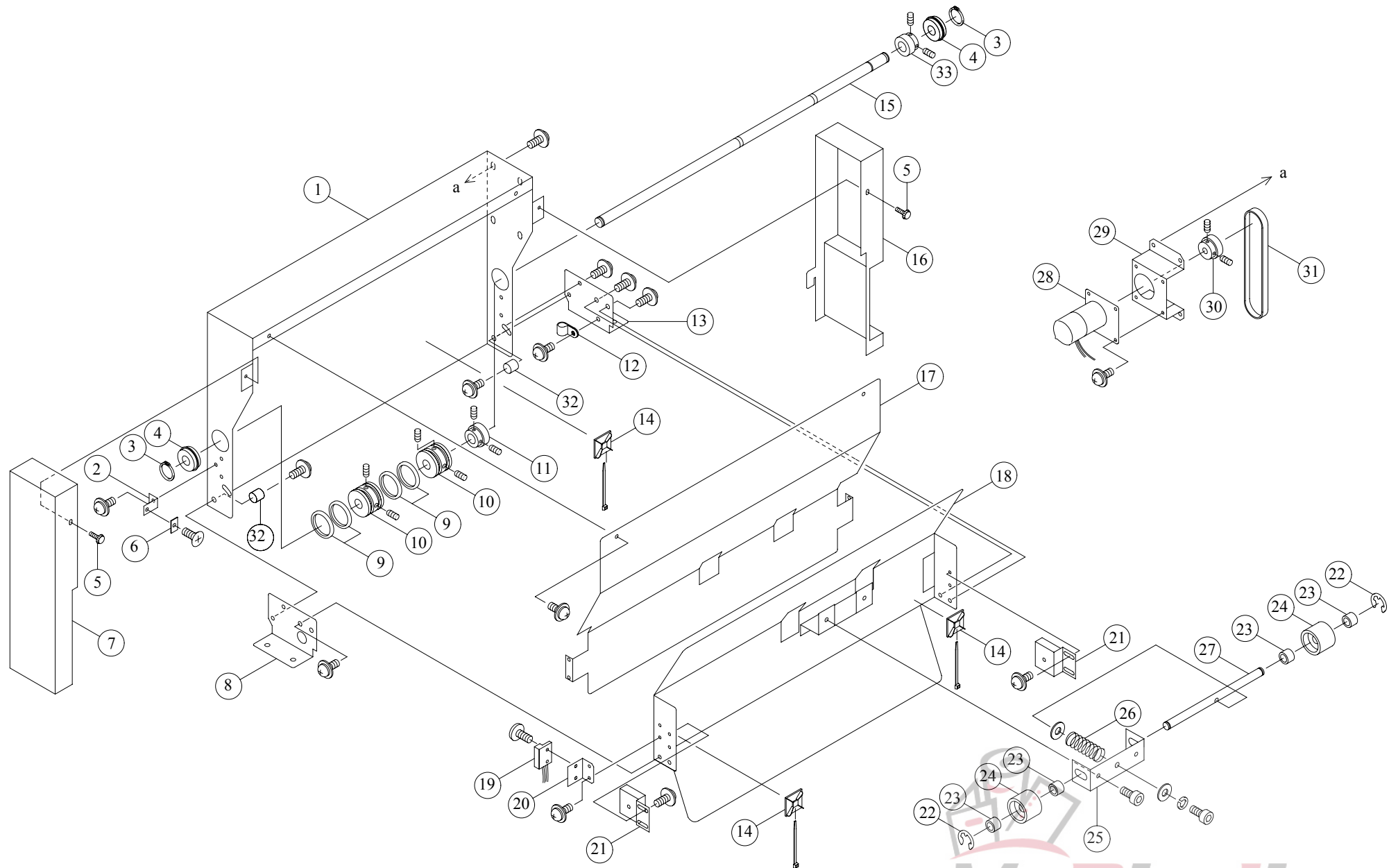

PS-P61

Fig. 1

INDEX	Parts No.	Description	Qty	Price	S/N From	To	Remarks
1	M041549-31	SIDE FRAME	1				
2	M041658-10	PLATE	1				
3	STW-10	SNAP RING	2				
4	4000912-00	BEARING	2				
5	M3-8	KNOB	2				
6	4003648-00	MAGNET	1				
7	M041656-10	COVER(F)	1				
8	M041548-31	BASE PLATE	1				
9	P22.4-1A	O-RING	4				
10	M041538-10	ROLLER	2				
11	M041540-00	PULLEY	1				
12	4002193-00	WIRE CLAMP	1				
13	M041641-13	BASE PLATE	1				
14	4004220-00	BASE	3				
15	M041539-10	DRIVE SHAFT	1				
16	M041655-10	COVER(R)	1				
17	M041546-15	GUIDE PLATE(F)	1				
18	M901153-11	GUIDE PLATE(R)	1				
19	A803201-00	SWITCH	1				
20	M041657-00	SWITCH MOUNT	1				
21	4011009-00	MAGNET	2				
22	ETW-7	SNAP RING	2				
23	M001898-03	SPACER	4				
24	M001846-02	TRANSPORT ROLLER	2				
25	M901300-00	BRACKET	1				
26	M016629-00	SPRING	1				
27	M041537-20	ROLLER SHAFT	1				
28	A803202-00	DC MOTOR	1				
29	M041545-20	MOTOR BASE	1				
30	M041540-00	PULLEY	1				
31	M041542-20	DRIVE BELT	1				

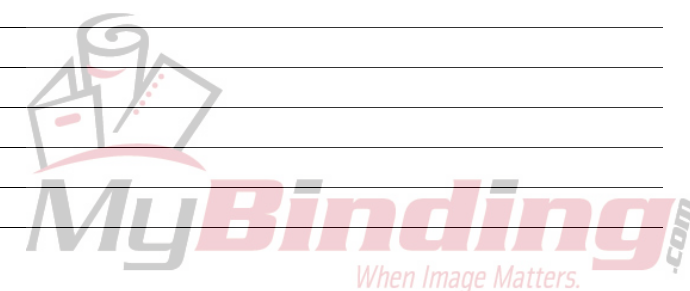

PS-P61

Fig. 1

INDEX	Parts No.	Description	Qty	Price	S/N From	To	Remarks
32	4X4	SPACER	2				
33	M041543-10	PULLEY	1				

This page is intentionally left blank.



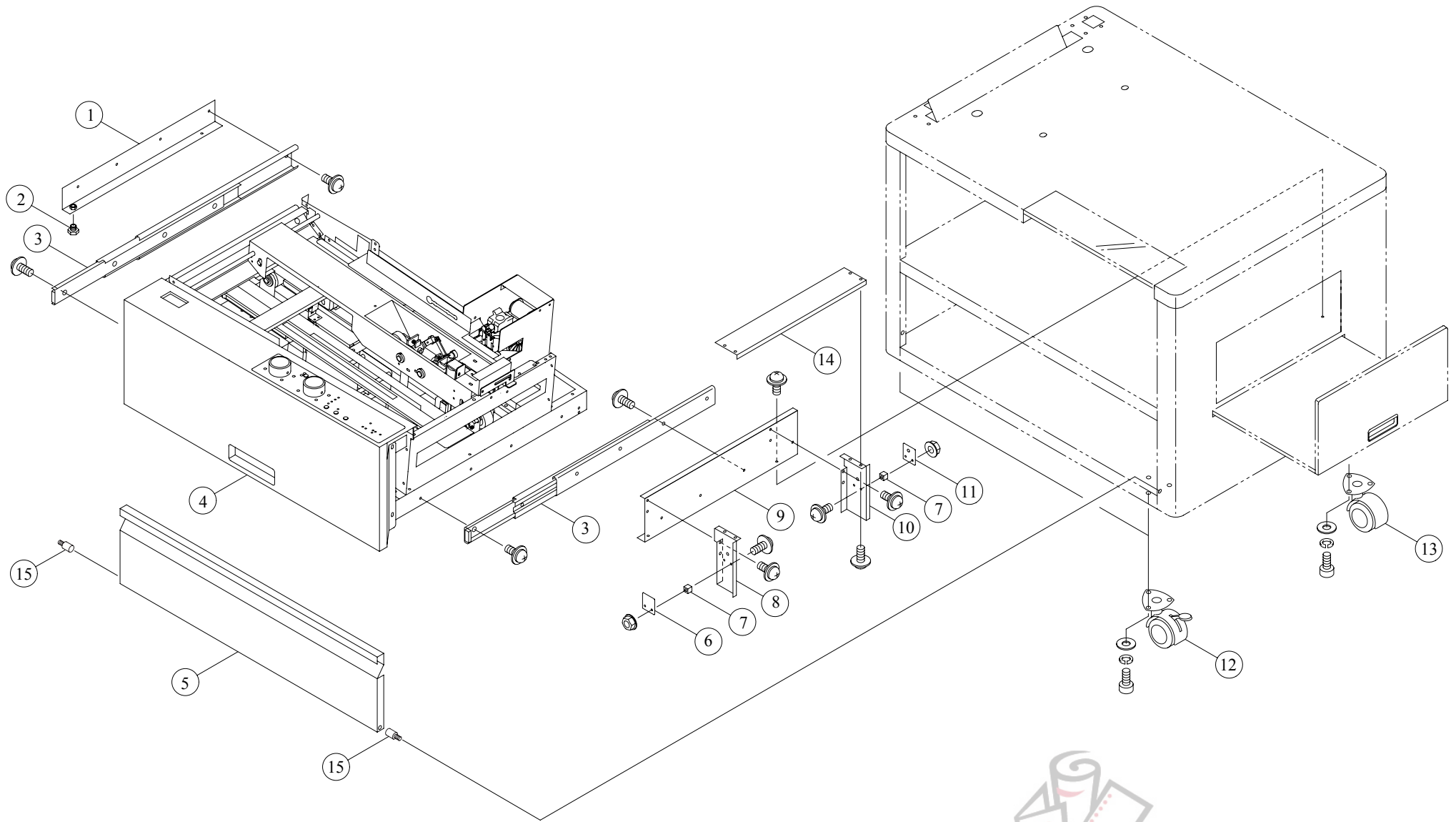

PS-P61

INDEX	Parts No.	Description	Qty	Price	S/N From	To	Remarks
1	M041522-00	RAIL(L)	1				
2	M021707-00	ADJUST BOLT	1				
3	4006983-00	RAIL	1				2pcs/set
4	M041511-11	FRONT COVER(U)	1				
5	M041513-01	FRONT COVER(L)	1			138899	
5	M041513-10	FRONT COVER(L)	1		139001		
6	A803203-01	SENSOR (PROJECTOR)	1			051899	
7	M001790-06	SPACER	4				
8	M041685-12	SENSOR COVER(F)	1				
9	M041523-12	RAIL(R)	1				
10	M041686-13	SENSOR COVER(R)	1				
11	A803204-01	SENSOR(RECIEVER)	1				
12	4006987-00	CASTER (A)	2				
13	4006986-00	CASTER (B)	2				
14	M074802-00	COVER	1				
15	UD4-10	SCREW	2		139001		



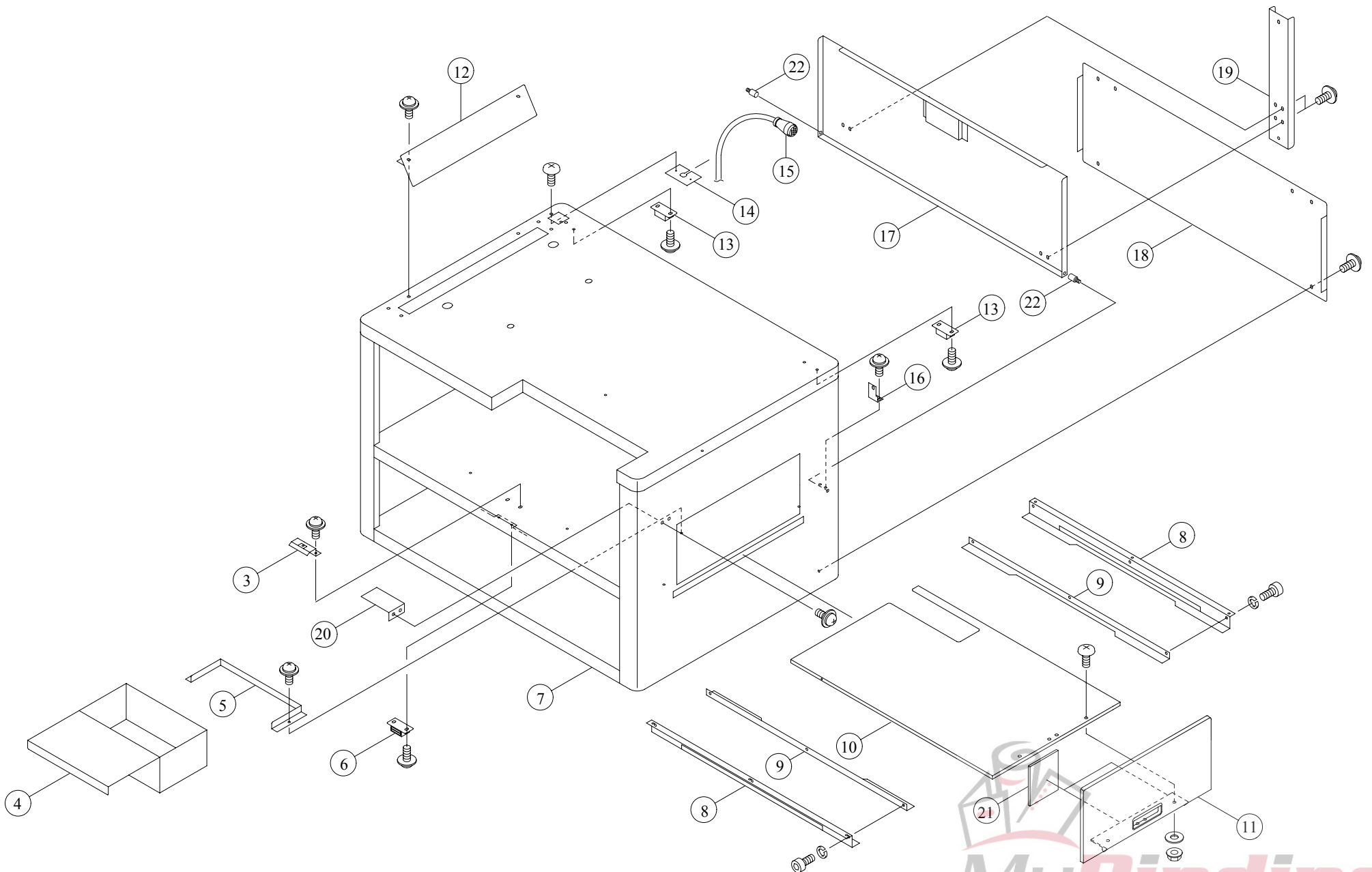

INDEX	Parts No.	Description	Qty	Price	S/N From	To	Remarks
3	M041524-21	HOLDER	1				
4	M041594-20	BOX	1				
5	M041593-11	GUIDE	1				
6	4006985-00	MAGNET A	1				
7	M041501-26	CHASSIS	1				
8	M041520-41	RAIL	2				
9	A803205-00	RAIL HOLDER	2				
10	M041519-21	SHEET TRAY	1				
11	M032257-11	TRAY SIDE PANEL	1				
12	M041550-03	GUIDE	1				
13	4011008-00	MAGNET	2				
14	M041672-01	PLATE	1				
15	4000791-00	CONNECTOR	1				
16	M041528-10	PLATE	1			051899	
17	M041514-30	REAR COVER(U)	1			138899	
17	M041514-40	REAR COVER(U)	1		139001		
18	M041517-20	REAR COVER(L)	1				
19	M074819-00	PLATE	2				
20	M074809-00	PLATE	1			-006917	
20	M074809-10	PLATE	1		-007901		
21	M074830-00	SPONGE	2		011001		
22	UD4-10	SCREW	2		139001		



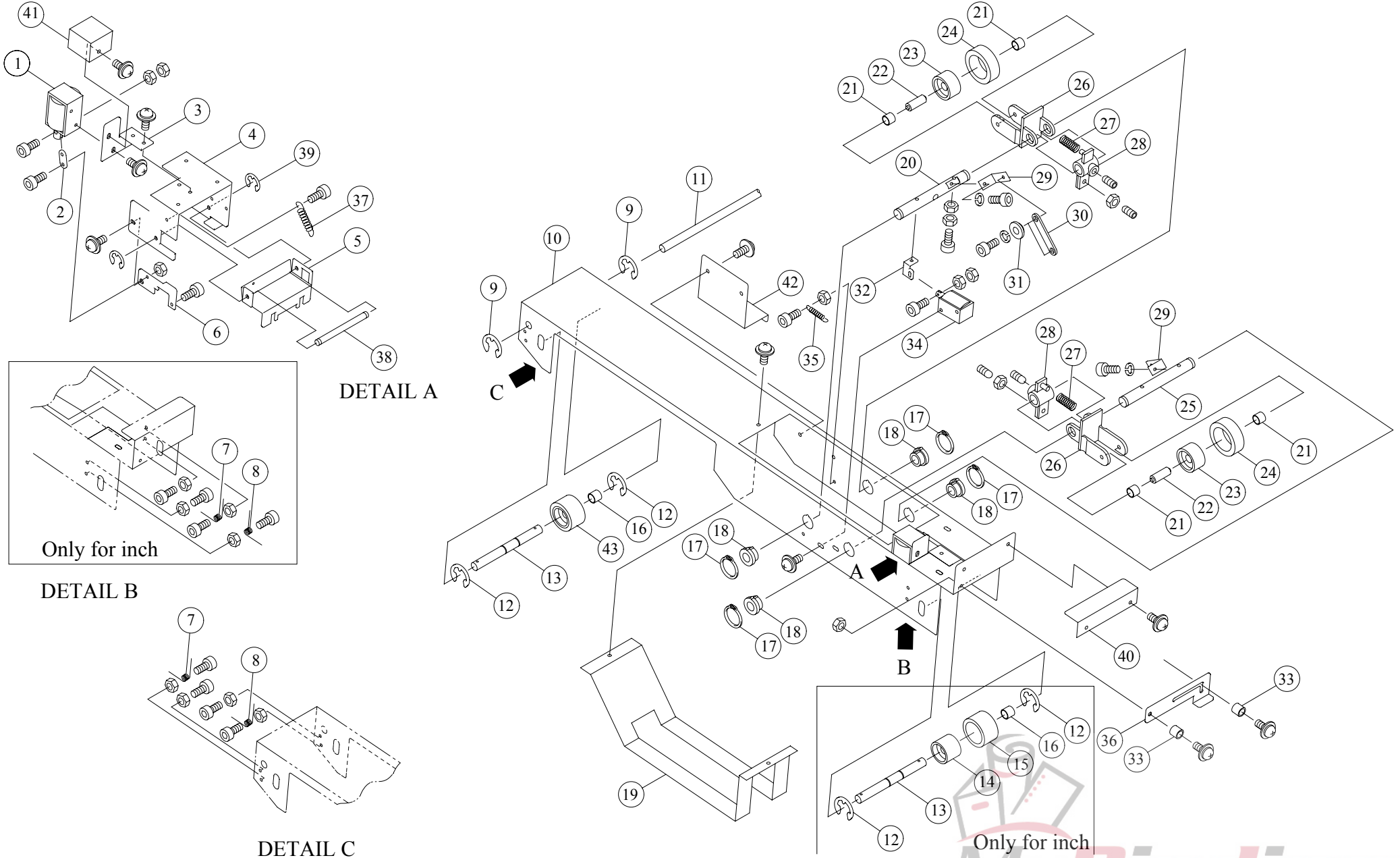

PS-P61

INDEX	Parts No.	Description	Qty	Price	S/N From	To	Remarks
1	A803206-00	SOLENOID	1				mm
2	M041577-01	LINK	1				mm
3	M901530-10	BRACKET	1				mm
4	M901254-31	B4 STOPPER BASE	1				mm
5	M901250-31	B4 STOPPER	1				mm
6	M901531-10	PLATE	1				mm
7	M021749-10	SPRING	2				
8	M021776-00	SPRING	2				
9	ETW-7	SNAP RING	2				
10	M041628-64	TRNSPORT GUIDE	1				
11	M041629-01	SHAFT	1				
12	ETW-7	SNAP RING	4				
13	M041631-11	SHAFT	2				
14	M001844-02	ROLLER BUSH	1				Inch
15	M001954-02	RUBBER ROLLER	1				Inch
16	M001898-03	SPACER	2				
17	STW-10	SNAP RING	4				
18	M001785-00	BUSH	4				
19	M041630-21	HOLDER	1				
20	M172951-00	SHAFT	1				
21	M001897-02	COLLAR	4				
22	M004228-01	ROLLER SHAFT	2				
23	M001952-01	ROLLER WHEEL	2				
24	M001953-02	SUPPORT ROLLER	2				
25	M172952-00	SHAFT	1				
26	M001955-02	ROLLER BRACKET	2				
27	M002790-01	ROLLER SPRING	2				
28	M001820-01	ADJUSTER	2				
29	M172953-00	PLATE	2				
30	M172954-00	LINK	1				
31	M172950-00	BUSH	2				

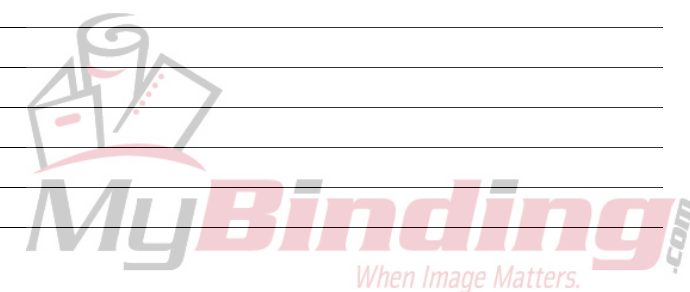

PS-P61

INDEX	Parts No.	Description	Qty	Price	S/N From	To	Remarks
32	M021778-00	LINK	1				
33	3X3	SPACER	1				
34	A803206-00	SOLENOID	1				
35	M021802-00	SPRING	1				
36	M901150-20	STOPPER	1				
37	M021800-01	SPRING	1				mm
38	M074801-01	SHAFT	1				mm
39	ETW-3	SNAP RING	1				mm
40	M074814-00	HANDLE	1				
41	M074812-00	SOLENOID COVER	1				mm
42	M074818-00	PLATE	1			-006917	
43	M072326-02	ROLLER	1				



This page is intentionally left blank.



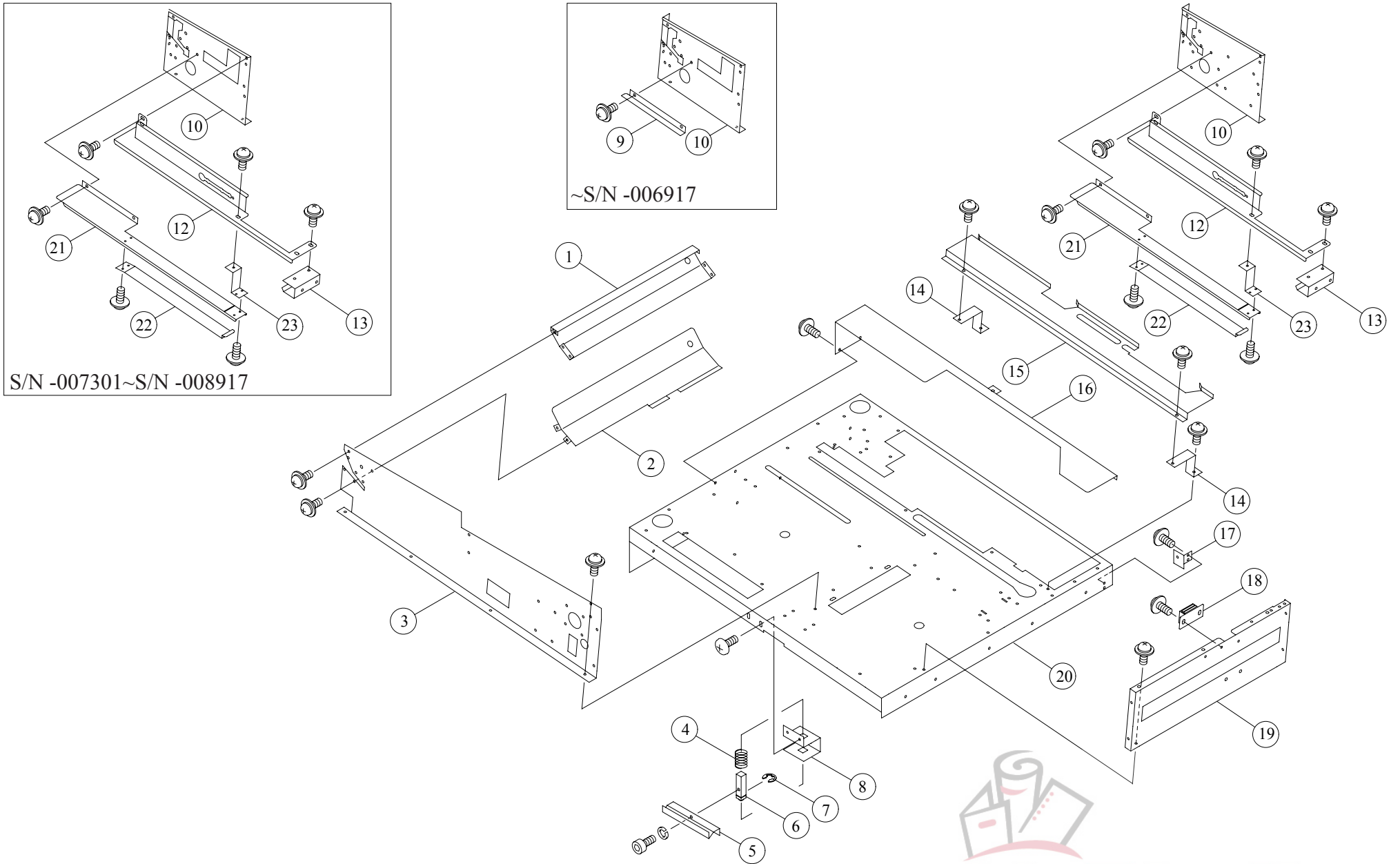

INDEX	Parts No.	Description	Qty	Price	S/N From	To	Remarks
1	M041535-22	GUIDE(U)	1				
2	M041536-32	GUIDE(L)	1				
3	M041531-22	SIDE FRAME	1				
4	M021892-00	SPRING	1				
5	M041681-00	KNOB	1				
6	M021891-01	PIN	1				
7	ETW-9	SNAP RING	1				
8	M021887-00	SLIDE	1				
9	M041684-10	GUIDE	1			-006917	
10	M041532-40	PLATE	1			-008917	
10	M041532-51	PLATE	1		001001	051899	
10	M041532-60	PLATE	1		100001		
12	M041659-40	PUNCH HOLDER	1			-006917	
12	M041659-41	PUNCH HOLDER	1		-007901		
13	M901305-20	PLATE	1				
14	M041621-10	Z-PLATE	2				
15	M041626-46	GUIDE	1				
16	M041623-13	SUPPORT PLATE	2			051899	
16	M041623-20	SUPPORT PLATE	2		100001		
17	M041529-10	PLATE	1			051899	
18	TL-75S	MAGNET	1				
19	M041534-52	EXIT PLATE	1				
20	M041530-60	BASE	1			-008917	
20	M041530-78	BASE	1		001001		
21	M074823-01	GUIDE	1		-007901		
22	M074826-00	SPRING	1		-007901		
23	M074824-10	PLATE	1		-007901		



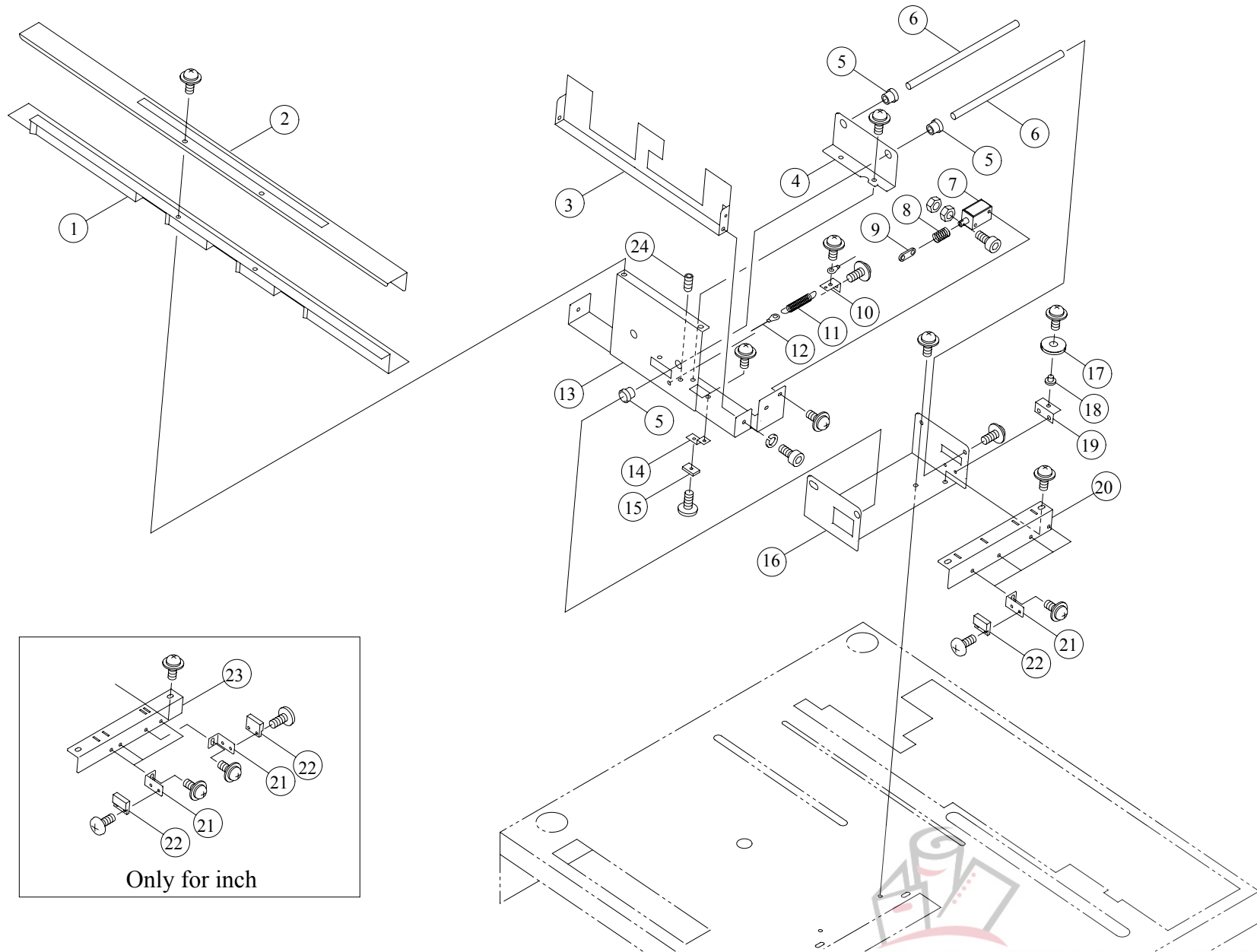

PS-P61

Fig. 6

INDEX	Parts No.	Description	Qty	Price	S/N From	To	Remarks
1	M041617-04	JOG GUIDE(L)	1				
2	M041619-21	SUPPORT	1				
3	M041613-21	JOG PLATE	1				
4	M901147-10	BRACKET	1				
5	4011016-00	BEARING	4				
6	M041615-00	SLIDE SHAFT	2				
7	A803206-00	SOLENOID	1				
8	M021803-00	SPRING	1				
9	M041577-01	LINK	1				
10	M041639-00	PLATE	1				
11	M021763-01	SPRING	1				
12	M041570-20	WIRE	1				
13	M041612-31	UNIT BASE	1				
14	M041674-00	PLATE	2				
15	4003648-00	MAGNET	1				
16	M041614-31	SLIDE BASE	1				
17	A803207-00	PULLEY	5				
18	M041663-00	PULLEY SHAFT	3				
19	M041566-00	PLATE	1				
20	M041670-10	PLATE	1				cm
21	M041673-10	BRACKET	4				
22	A803201-00	SWITCH	4				
23	M041671-10	PLATE	1				INCH
24	4007706-00	PLUNGER	1				

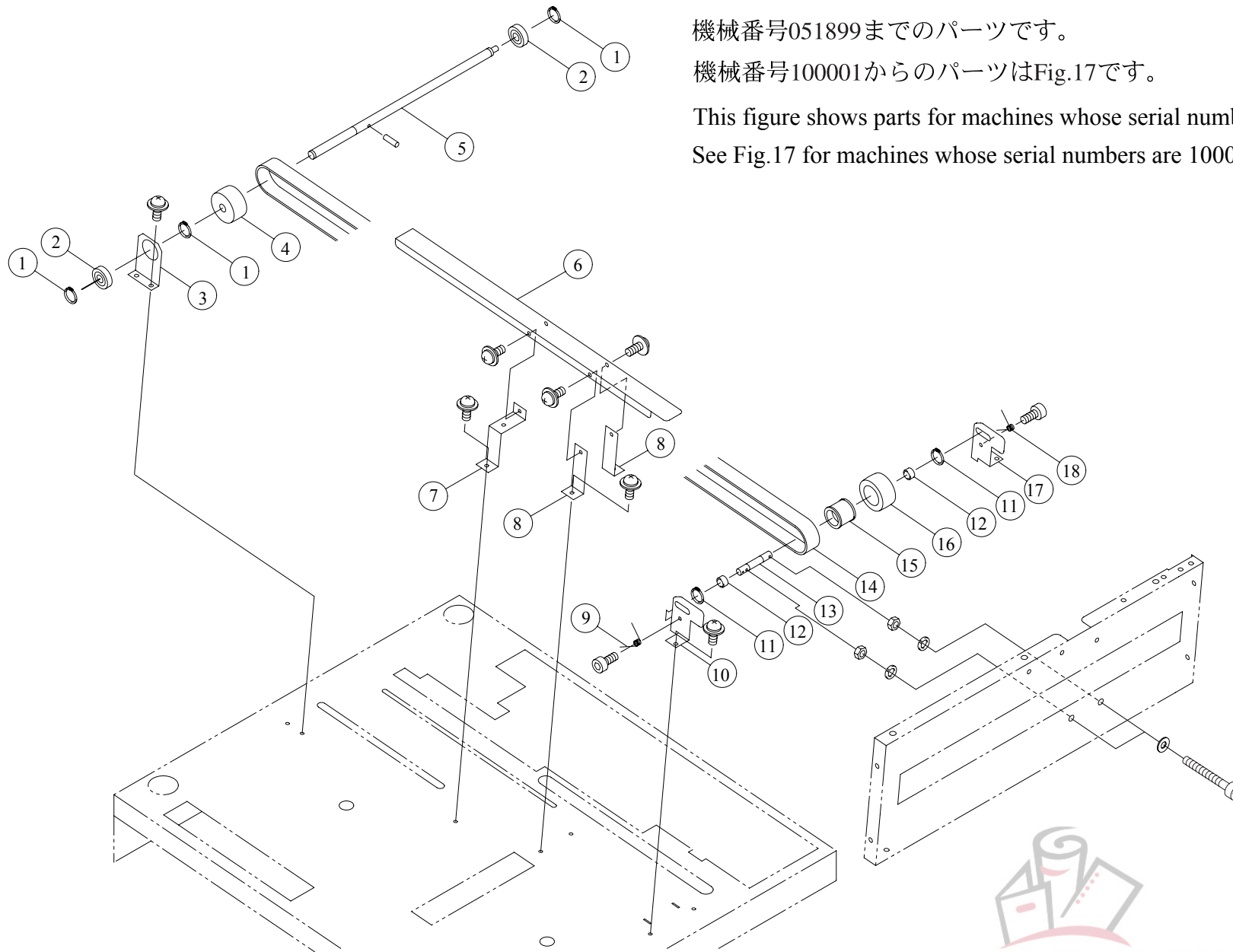

機械番号051899までのパーツです。

機械番号100001からのパーツはFig.17です。

This figure shows parts for machines whose serial numbers are 051899 or below.

See Fig.17 for machines whose serial numbers are 100001 or above.

INDEX	Parts No.	Description	Qty	Price	S/N From	To	Remarks
1	STW-10	SNAP RING	2			051899	
2	4000912-00	BEARING	2				
3	M041554-11	BRACKET	1			051899	
4	M900961-10	DRIVE PULLEY	1			051899	
5	M041551-30	DRIVE SHAFT	1			-008917	
5	M041551-50	DRIVE SHAFT	1		001001	051899	
6	M041622-10	BELT SUPPORT	1			051899	
7	M041642-20	BRACKET(A)	1			051899	
8	M041643-20	BRACKET(B)	2			051899	
9	M021745-00	SPRING	1			036899	
10	M041645-21	BRACKET	1			-008917	
10	M041645-31	BRACKET	1		001001	051899	
11	STW-8	SNAP RING	2			051899	
12	M001897-02	COLLAR	4			051899	
13	M041555-01	ROLLER SHAFT	1			051899	
14	M041606-00	BELT	1				
15	M001844-02	ROLLER BUSH	1			051899	
16	M001954-02	RUBBER ROLLER	3			051899	
17	M041644-21	BRACKET	1			-008917	
17	M041644-31	BRACKET	1		001001	051899	
18	M021744-00	SPRING	1			036899	

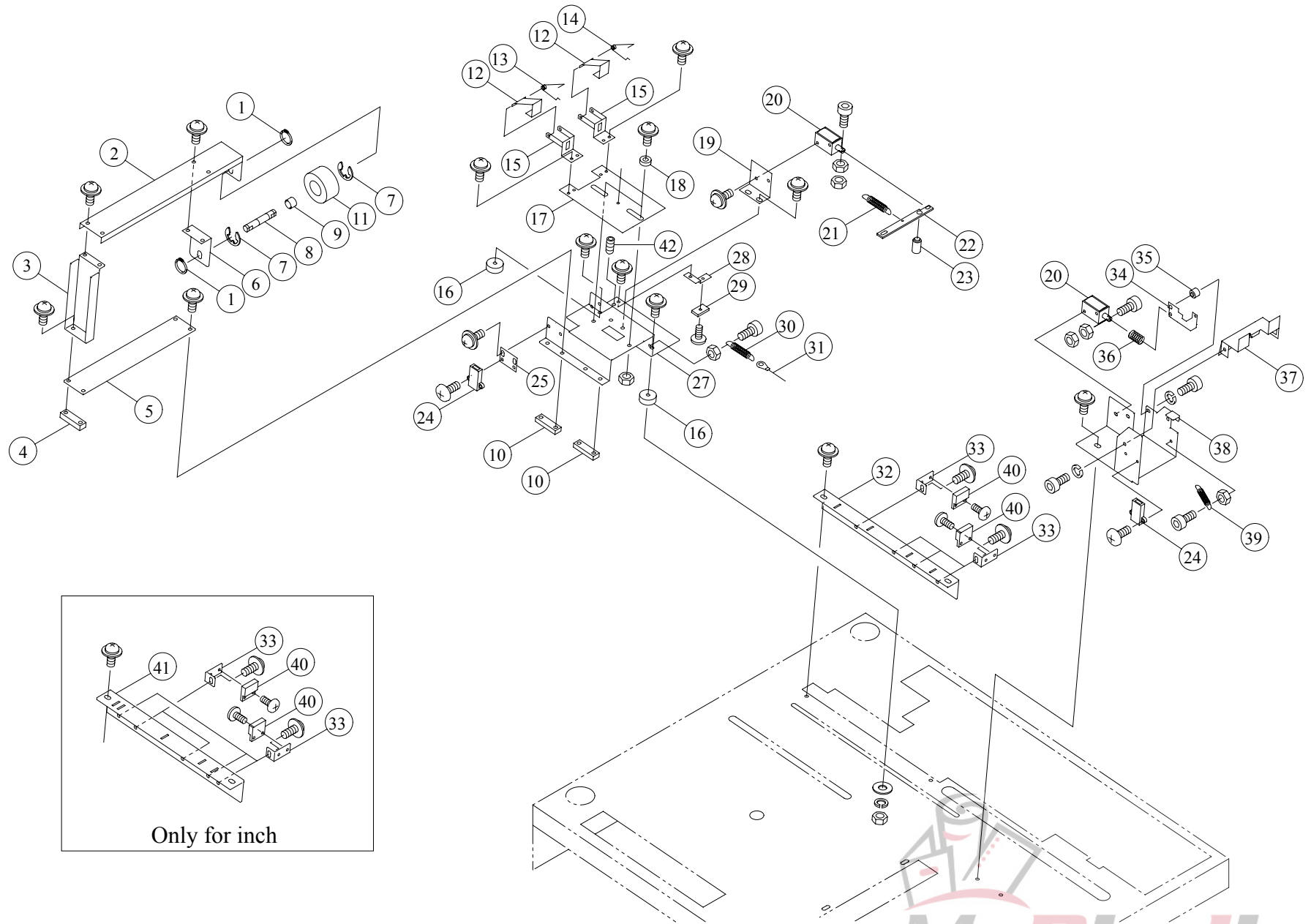

INDEX	Parts No.	Description	Qty	Price	S/N From	To	Remarks
1	STW-8	SNAP RING	2				
2	M041602-31	ROLLER ARM	1				
3	M041604-10	ARM STAY	1				
4	M041611-20	ARM SLIDE	1				
5	M041605-11	ARM BASE	1				
6	M041603-31	BRACKET	1				
7	ETW-7	SNAP RING	2				
8	M041609-21	ROLLER SHAFT	1				
9	M001898-03	SPACER	1				
10	M041608-30	ARM SLIDE	3				
11	A803208-00	ROLLER	1				
12	M021791-01	JOG PLATE	2				
13	M021795-02	SPRING A	1				
14	M021895-00	SPRING B	1				
15	M021792-00	HOLDER	2				
16	M041600-20	SLIDE SPACER	2				
17	M041599-00	SLIDE PLATE	1				
18	M041607-00	SLIDE GUIDE	2				
19	M041597-20	BRACKET	1				
20	A803206-00	SOLENOID	1				
21	M021802-00	SPRING	2				
22	M041598-00	LEVER	1				
23	M041595-11	LEVER PIN	1				
24	A803209-00	SENSOR	1				
25	M041638-01	BRACKET	1				
27	M041601-40	SLIDE BASE	1				
28	M901301-11	BRACKET	1				
29	4003648-00	MAGNET	1				
30	M021763-01	SPRING	1				
31	M041569-10	WIRE	1				
32	M041669-30	PLATE	1				

PS-P61

Fig. 8

INDEX	Parts No.	Description	Qty	Price	S/N From	To	Remarks
33	M041673-10	BRACKET	4				
34	M021799-01	LINK PLATE	1				
35	M021798-01	PIN	1				
36	M021803-00	SPRING	1				
37	M021797-00	STOPPER	1				
38	M041616-01	STOPPER BASE	1				
39	M021800-01	SPRING	1				
40	A803201-00	SWITCH	4				
41	M041677-20	PLATE	1				INCH
42	4007706-00	PLUNGER	1				

This page is intentionally left blank.



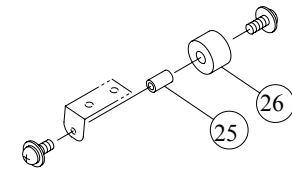
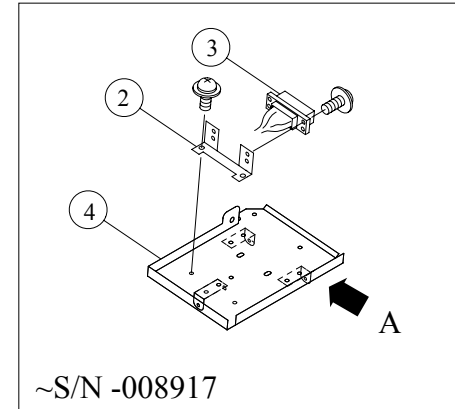
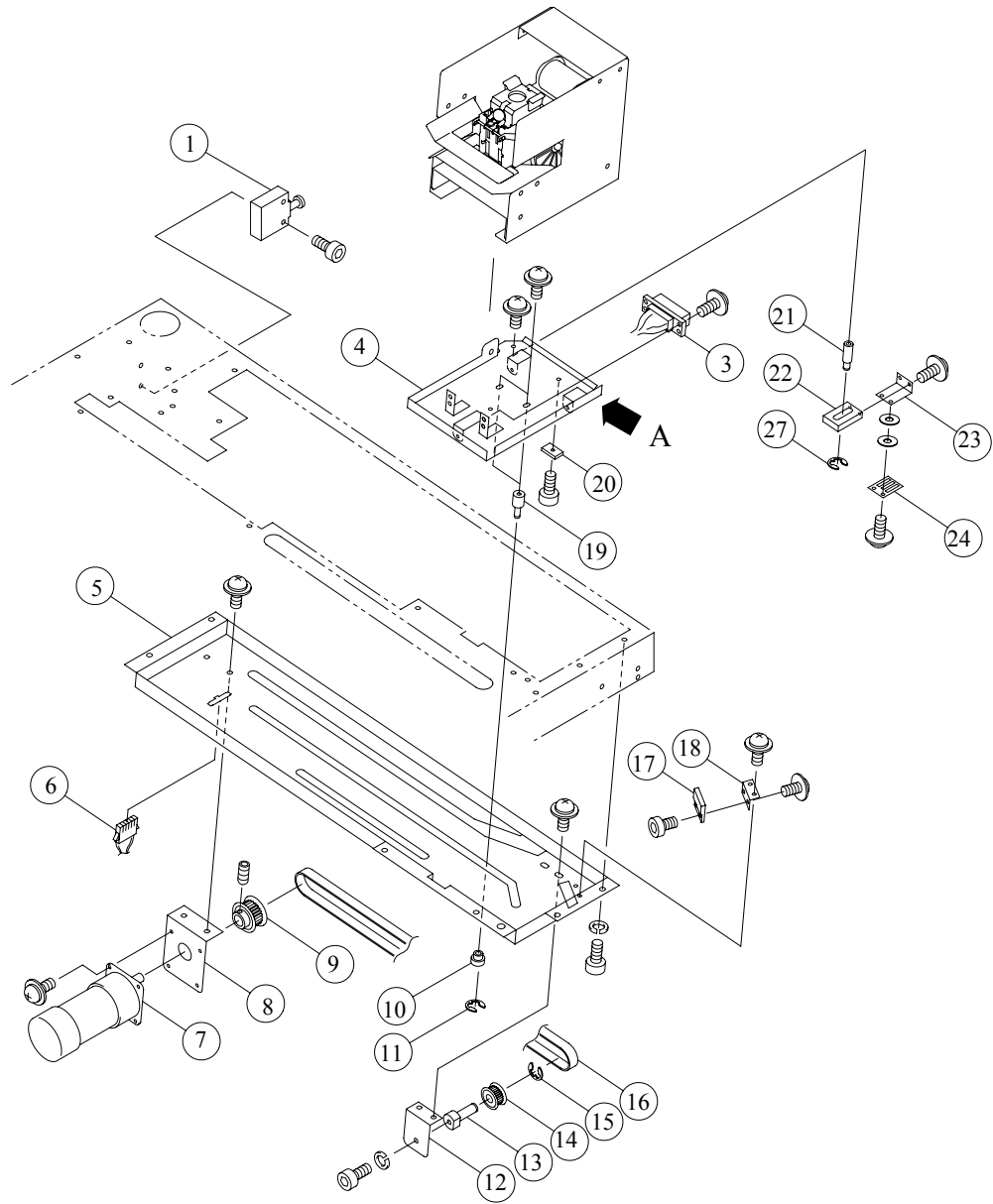

DETAIL A

INDEX	Parts No.	Description	Qty	Price	S/N From	To	Remarks
1	4011033-00	SWITCH	1				
2	M041581-10	BRACKET	1			-008917	
3	4006984-00	CONNECTOR	1				
4	M041578-73	BASE	1		001001		
4	M901151-22	BASE	1			-008917	
5	M041652-33	SLIDE BASE	1				
6	4007007-00	CONNECTOR	1				
7	A803210-00	DC MOTOR	1				
8	M041697-10	BRACKET	1				
9	A803211-00	PULLEY	1				
10	M041692-01	GUIDE ROLLER	2				
11	ETW-4	SNAP RING	1				
12	M041696-01	BRACKET	1			051899	
12	M041696-10	BRACKET	1		100001		
13	M901142-12	PULLEY SHAFT	1			051899	
13	M901142-20	PULLEY SHAFT	1		100001		
14	A803212-00	PULLEY	1			051899	
14	M087669-10	IDLER	1		100001		
15	ETW-7	SNAP RING	1				
16	4011327-00	TIMING BELT	1				
17	A803201-00	SWITCH	1				
18	M041668-10	BRACKET	2				
19	M041693-02	ROLLER SHAFT	2				
20	4003648-00	MAGNET	1				
21	M074820-10	GUIDE PIN	1				
22	M041699-10	PIN HOLDER	1				
23	M901141-10	BRACKET	1				
24	M041698-10	BELT HOLDER	1				
25	M041691-00	ROLLER SHAFT	3				
26	M172956-00	ROLLER	3				



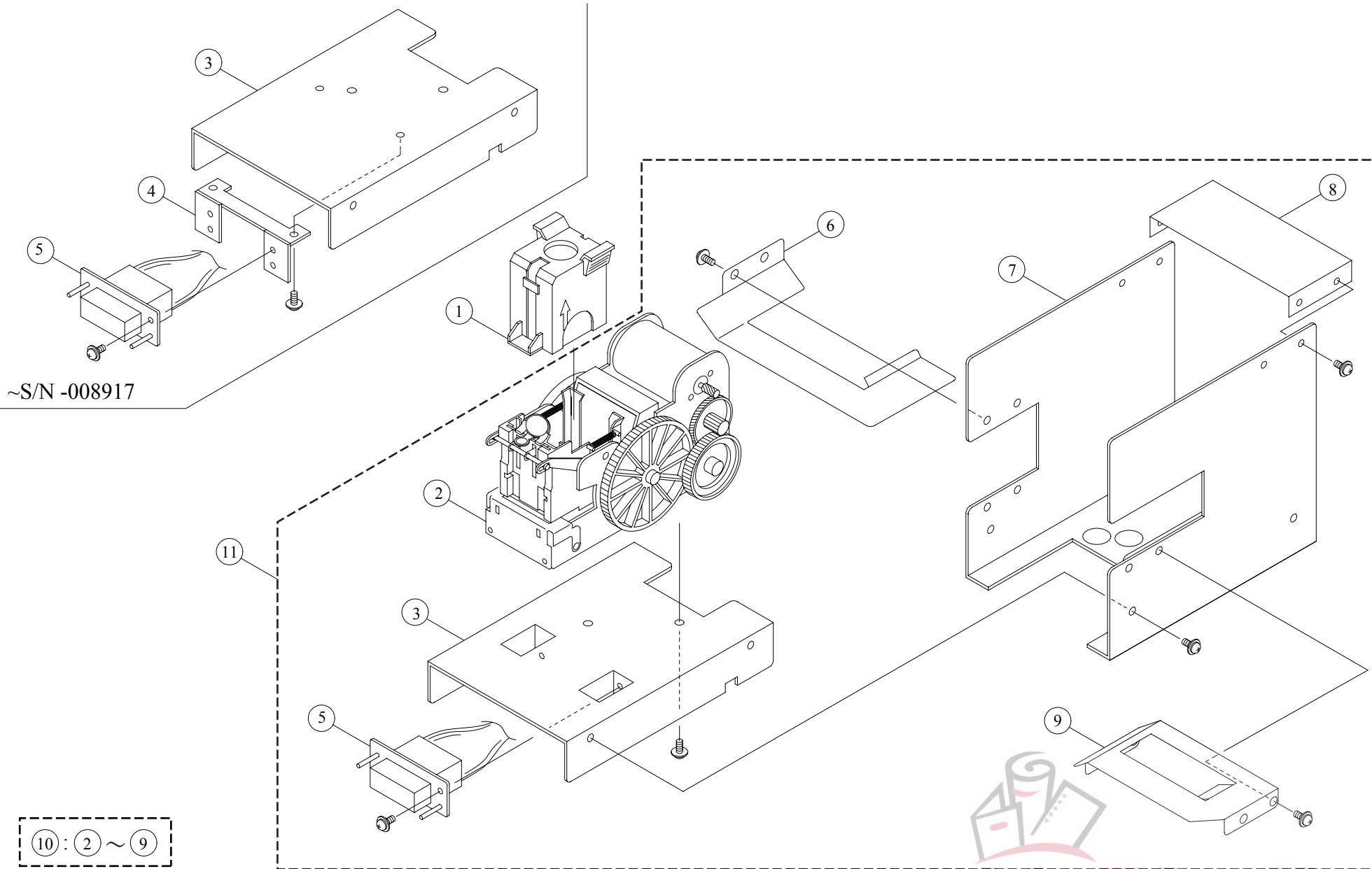

PS-P61

Fig. 10

INDEX	Parts No.	Description	Qty	Price	S/N From	To	Remarks
1	4009362-00	STAPLE NO.510	1				
2	4009185-00	STAPLER UNIT	1				
3	M041572-21	STAPLE BASE	1			-008917	
3	M041572-25	STAPLE BASE	1		001001		
4	M041581-10	BRACKET	1			-008917	
5	4006982-00	CONNECTOR	1				
6	M041575-42	GUIDE(U)	1				
7	M041571-43	HOUSING	1				
8	M041576-00	STAY	1				
9	M041574-31	GUIDE(L)	1				
10	A983223-00	STAPLE UNIT AS	1			-008917	IND.2-9
11	A983222-00	STAPLE UNIT AS	1		001001		IND.2&3&5-9



機械番号-008917までのパーツです。

機械番号001001からのパーツはFig.16です。

This figure shows parts for machines whose serial numbers are -008917 or below.

See Fig.16 for machines whose serial numbers are 001001 or above.

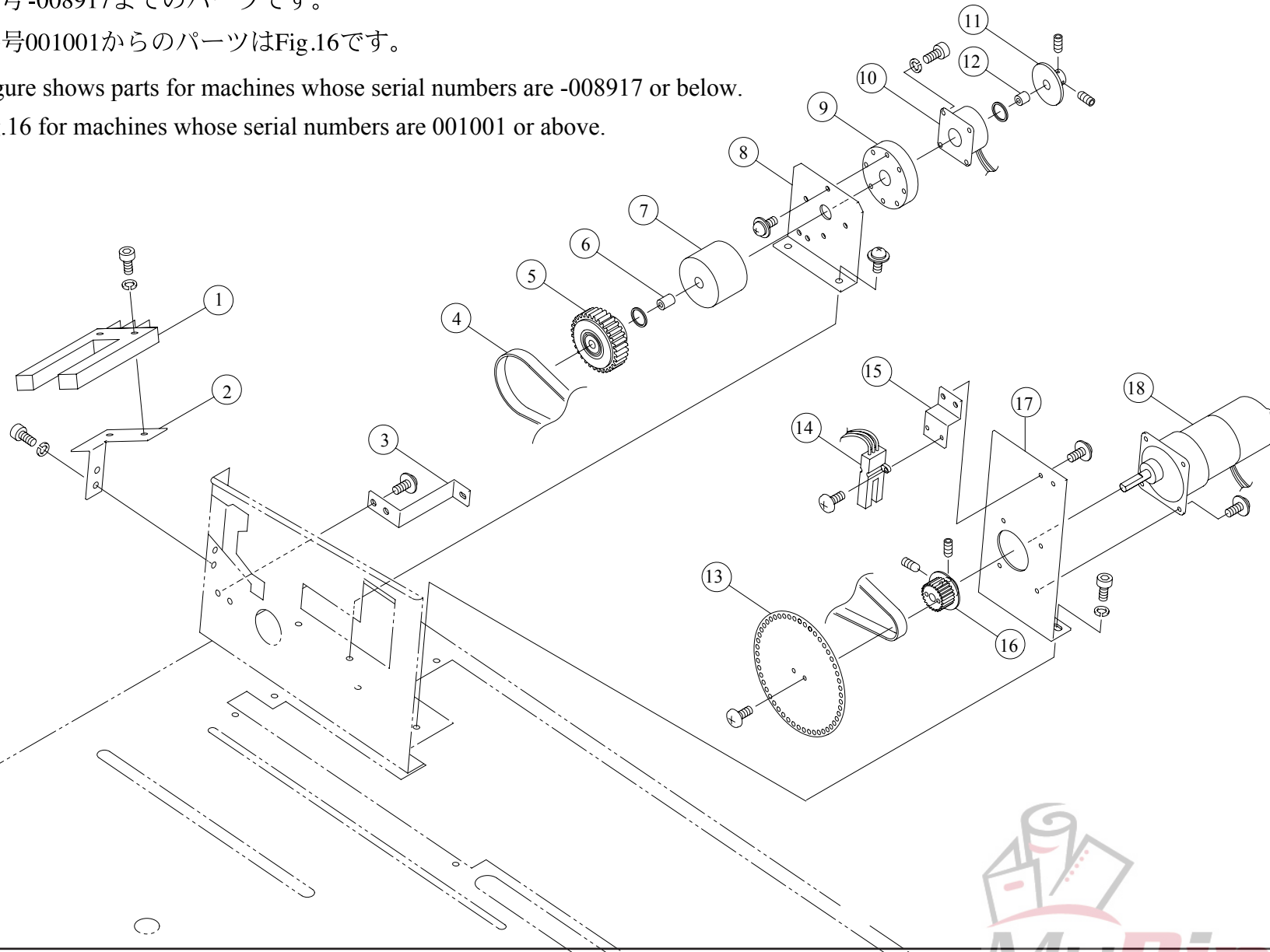

INDEX	Parts No.	Description	Qty	Price	S/N From	To	Remarks
1	4006989-00	SENSOR	1				
2	M041625-00	BRACKET	1				
3	M041662-00	SUPPORT	1			-008917	
4	98XL025	TIMING BELT	1			-008917	
5	A803213-00	TIMING PULLEY	1			-008917	
6	M901144-10	COLLAR	1			-008917	
7	A803214-00	CLUTCH	1			-008917	
8	M041683-02	BRACKET	1			-008917	
9	M041660-10	BRAKE HOUSING	1			-008917	
10	A803215-00	BRAKE	1			-008917	
11	112-03-11	ARAMATURE	1			-008917	
12	M041661-00	COLLAR	1			-008917	
13	M900975-00	PLATE	1			-008917	
14	4005256-00	SENSOR	1			-008917	
15	M900974-10	BRACKET	1			-008917	
16	A803216-00	TIMING PULLEY	1			-008917	
17	M041552-20	MOTOR BASE	1			-008917	
18	26C-AM-5-Y195	MOTOR	1			-008917	

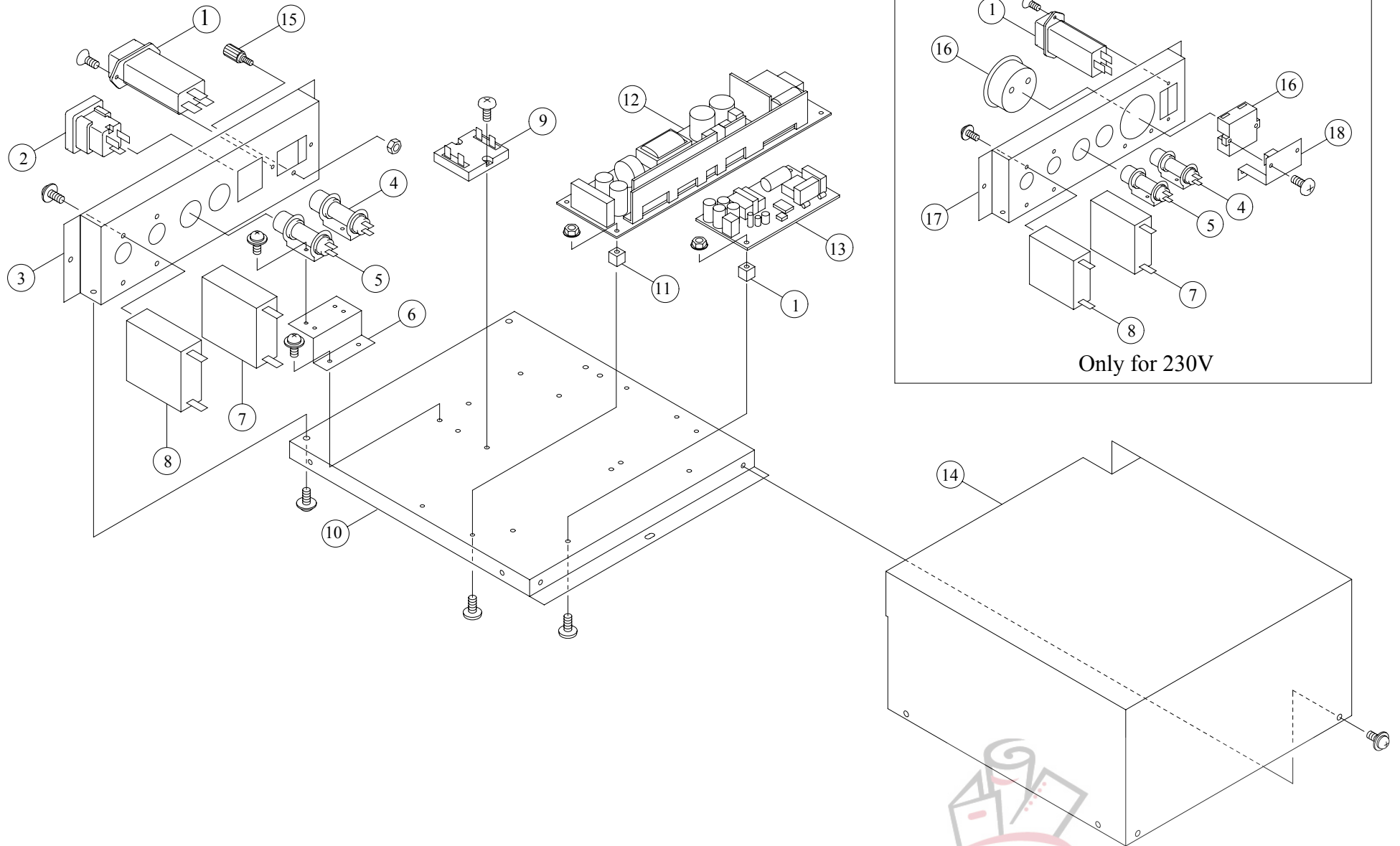

PS-P61

Fig. 12

INDEX	Parts No.	Description	Qty	Price	S/N From	To	Remarks
1	4008583-00	NOISE FILTER	1				
2	4007997-00	RECEPTACLE	1				
3	M041633-21	BRACKET	1				
4	4003597-00	CIRCUIT PROTECTOR	1				
5	4005456-00	CIRCUIT PROTECTOR	1				
6	M021870-00	MOUNT PLATE	1				
7	4007676-00	CIRCUIT PROTECTOR	1				
8	NRAS11001A	CIRCUIT PROTECTOR	1				
9	4006992-00	SSR	1				
10	M041635-31	CHASSIS	1				
11	M001790-06	SPACER	6				
12	4011029-00	POWER SUPPLY	1				100V/115V
12	4011030-00	POWER SUPPLY(24V)	1				230V
13	4011267-00	POWER SUPPLY(5V)	1				100V/115V
13	4011268-00	POWER SUPPLY(5V)	1				230V
14	M041596-20	COVER	1				
15	M002043-00	GROUND TERMINAL	1				
16	4006964-00	RECEPTACLE	1				230V
17	M041634-20	BRACKET	1				230V
18	M074821-00	BRACKET	1				230V

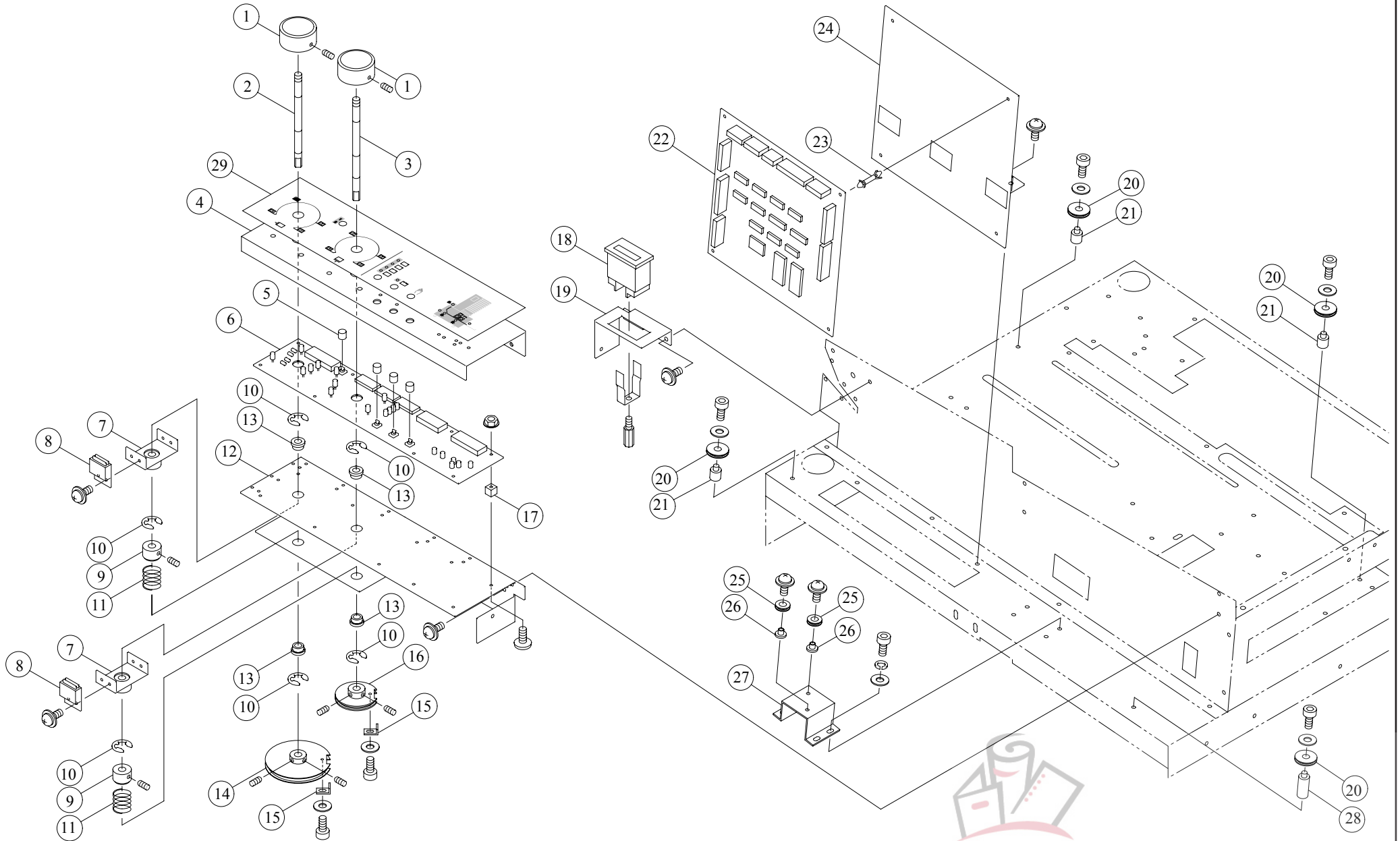

PS-P61

INDEX	Parts No.	Description	Qty	Price	S/N From	To	Remarks
1	M041562-11	KNOB	2				
2	M041558-01	SHAFT	1				
3	M041557-10	SHAFT	1				
4	M900984-02	PANEL	1				cm
4	M900985-02	PANEL	1				INCH
5	M032234-10	BUTTON	4				
6	QPW-458	P.C.B.	1				
7	A803218-00	BASE	2				
8	4007305-00	MAGNET	2				
9	M041568-00	BOSS	4				
10	ETW-7	SNAP RING	4				
11	M041688-10	LOCK SPRING	2				
12	M041556-22	SHAFT BASE	1				
13	M001784-00	BUSH	4				
14	M041559-11	PULLLEY	1				
15	M021783-00	WIRE HOLDER	2				
16	M041560-11	PULLLEY	1				
17	M001790-06	SPACER	4				
18	4001564-00	COUNTER	1				
19	M041544-01	BRACKET	1				
20	A803207-00	PULLLEY	5				
21	M041564-11	SHAFT	4				
22	QPW-457	P.C.B.	1				
23	4000951-00	SPACER	4		001001		
23	M001790-06	SPACER	4			-008917	
24	M041632-11	CHASSIS	1		001001		
24	M041675-00	CHASSIS	1			-008917	
25	A803219-00	PULLLEY	2				
26	M041663-00	PULLLEY SHAFT	3				
27	M041561-20	BASE	1				
28	M041565-10	SHAFT(L)	1				



PS-P61

Fig. 13

INDEX	Parts No.	Description	Qty	Price	S/N From	To	Remarks
29	4011278-00	PANEL LABEL	1				cm
29	4011280-00	PANEL LABEL	1				INCH



This page is intentionally left blank.



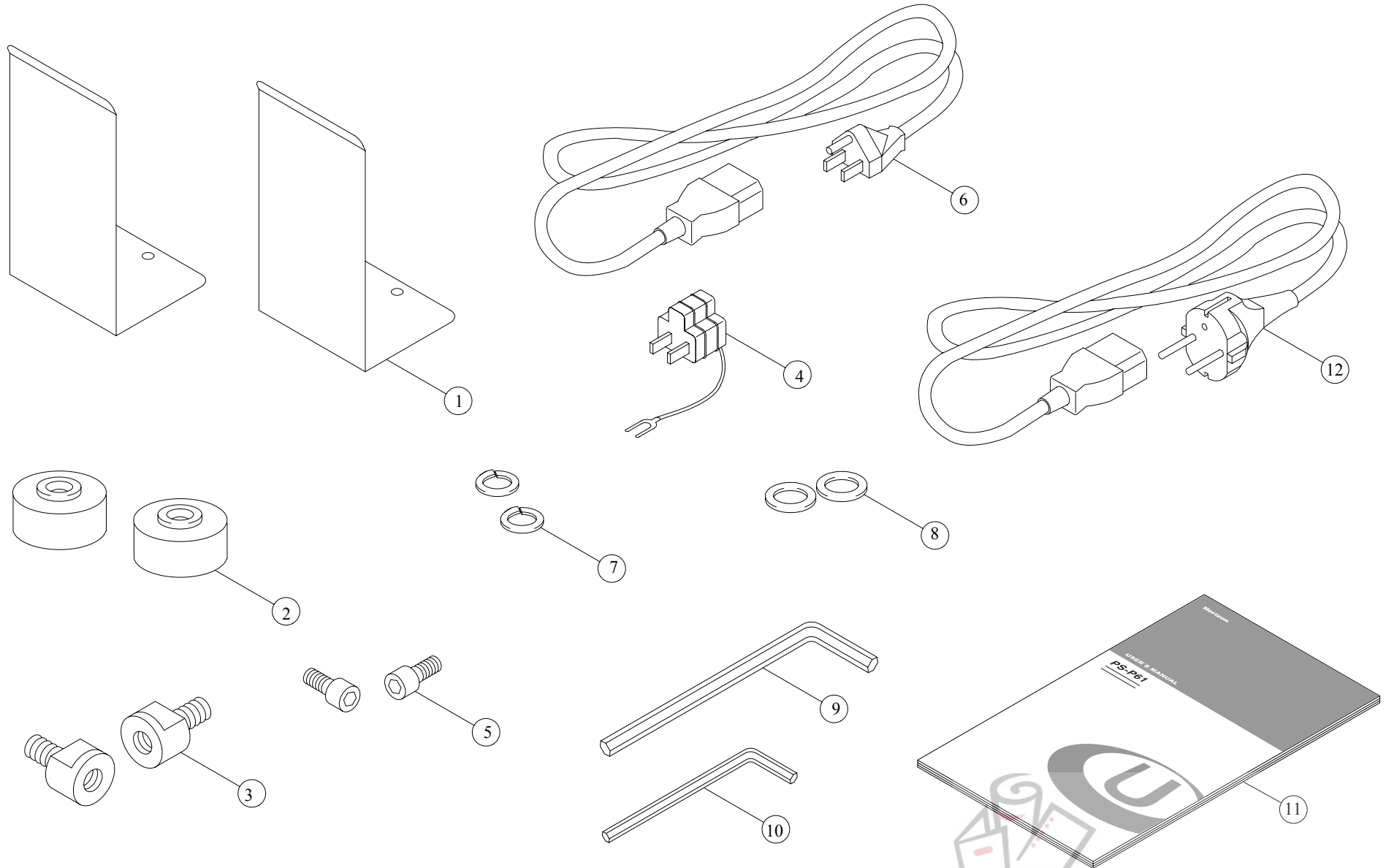

PS-P61

Fig. 14

INDEX	Parts No.	Description	Qty	Price	S/N From	To	Remarks
1	A983225-00	SHEET GUIDE	2				
2	M021894-01	LEG	2				
3	M021879-00	LOCK BOLT	2				
4	4007858-00	ADAPTER	1				100V/115V
5	SB10-15	SCREW	2				
6	4011011-10	POWER CABLE	1				100V/115V
7	W10S	SPRING WASER	2				
8	W10	WASHER	2				
9	4001439-00	ALLEN WRENCH	1				4mm
10	4001438-00	ALLEN WRENCH	1		040001		3mm
11	UM201013	OPERATION MANUAL	1				
12	4007737-00	POWER CABLE	1				230V

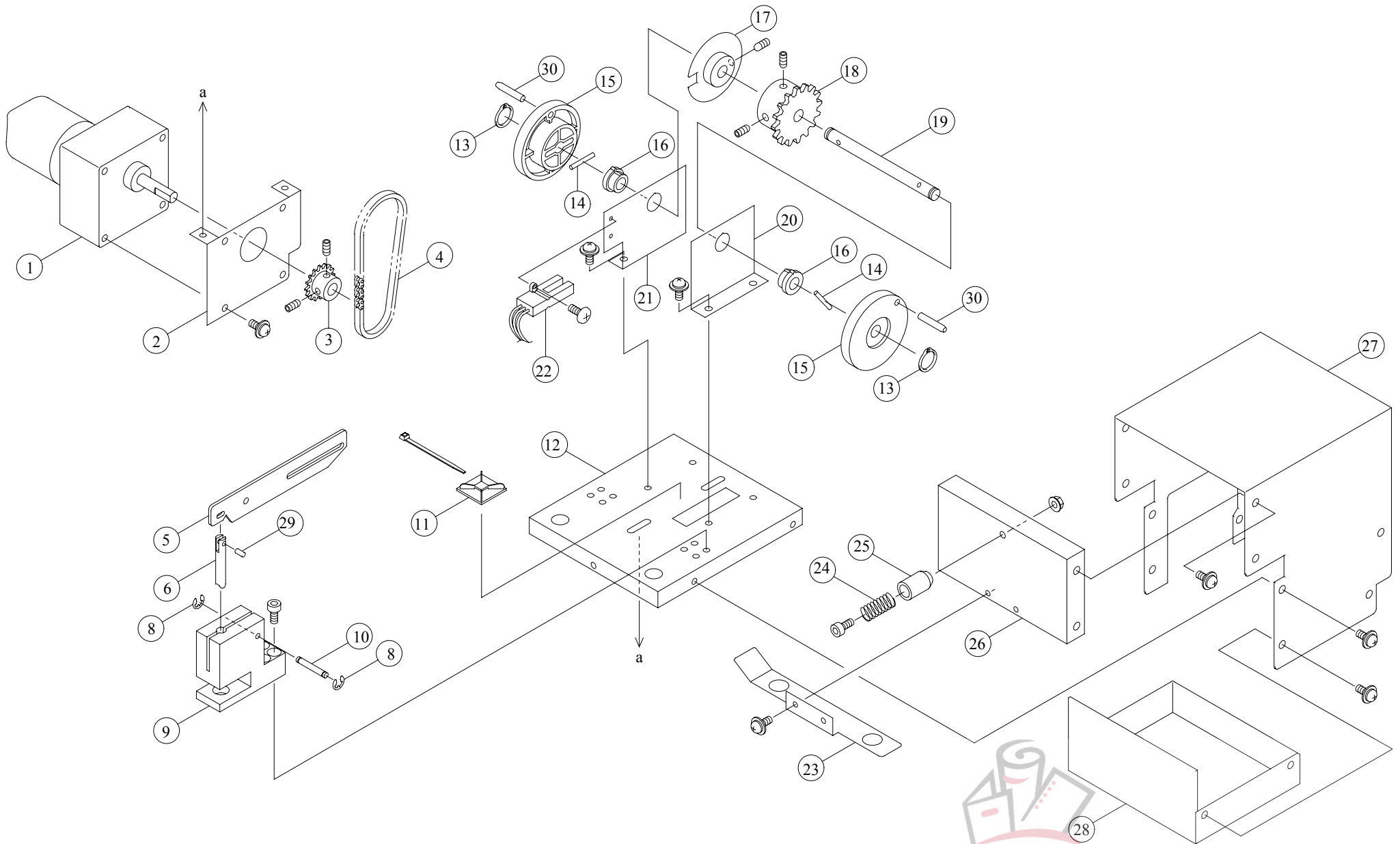

INDEX	Parts No.	Description	Qty	Price	S/N From	To	Remarks
1	A803220-00	MOTOR	1				
2	M041590-20	BRACKET	1				
3	M021823-00	SPROCKET	1				
4	NO15-44L	CHAIN	1				
5	M021826-00	LINK	2				
6	M021827-01	PUNCH	2				
8	ETW-3	SNAP RING	4				
9	A803221-00	DIE	2				
10	CCPH4-21	PIN	2				
11	MB-3A	BASE	1				
12	M041591-31	FRAME	1				
13	STW-8	SNAP RING	2				
14	PP4-15H7	PIN	2				
15	M021825-01	CRANK DISC	2				
16	M001784-00	BUSH	8				
17	M021828-01	SENSOR CAM	1				
18	M901304-00	SPROCKET	1				
19	M021824-01	CRANK SHAFT	1				
20	M021821-00	BUSH BRACKET(L)	1				
21	M021820-00	BUSH BRACKET(R)	1				
22	4005256-00	SENSOR	1				
23	M041592-30	GUIDE	1				
24	M002790-01	ROLLER SPRING	1				
25	M901302-00	KNOB	1				
26	M041650-11	COVER(L)	1				
27	M041647-30	COVER(U)	1				
28	M041648-20	BASE	2				
29	4006970-00	PIN	2				
30	MS4-15	PIN	2				

機械番号001001から051899までのパーツです。
機械番号100001からのパーツはFig.17です。

This figure shows parts for machines whose serial numbers are from 001001 to 051899.
See Fig.17 for machines whose serial numbers are 100001 or above.

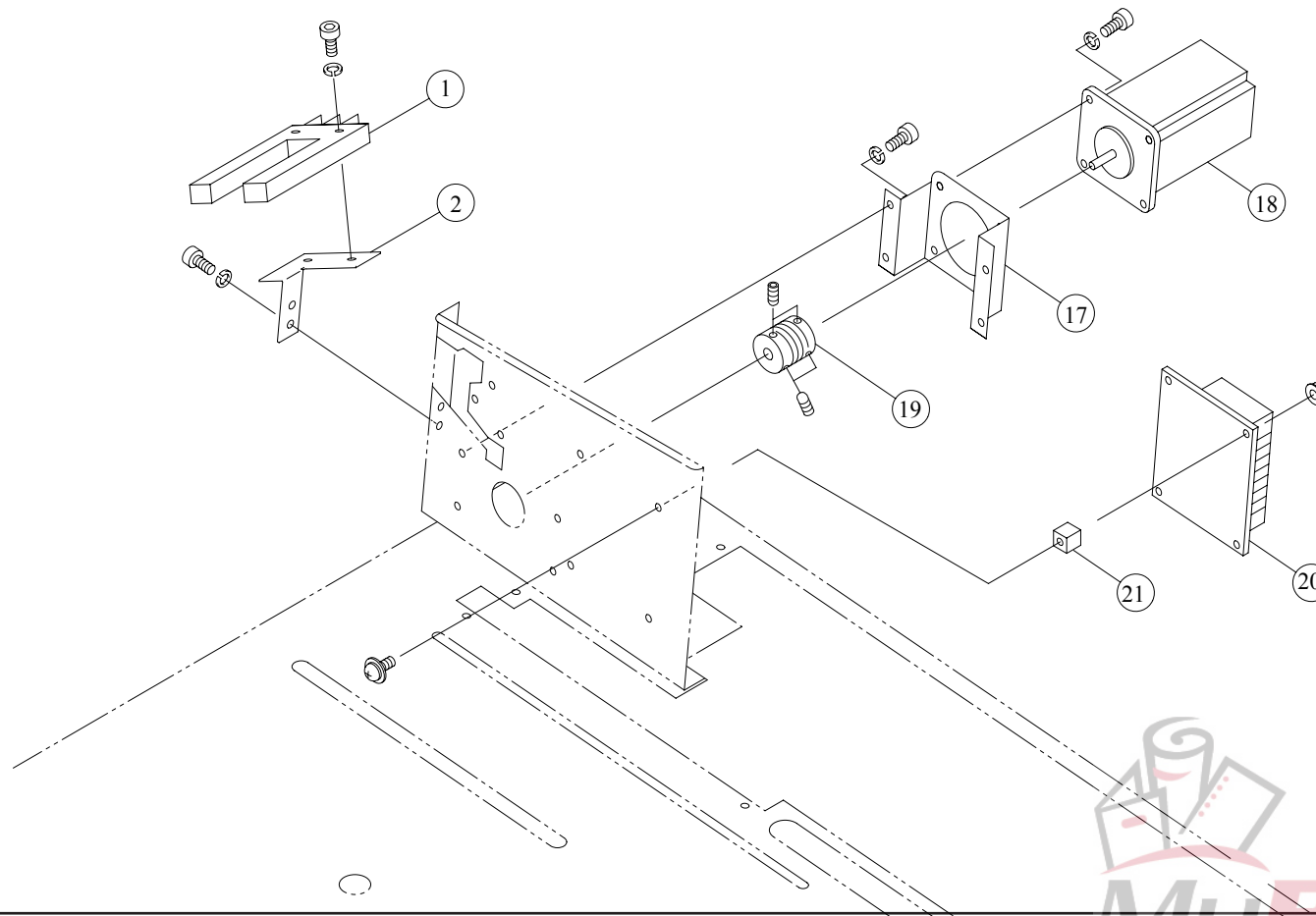

PS-P61

Fig. 16

INDEX	Parts No.	Description	Qty	Price	S/N From	To	Remarks
1	4006989-00	SENSOR	1				
2	M041625-00	BRACKET	1				
17	M041552-30	MOTOR BASE	1		001001	051899	
18	PK268-02A	MOTOR	1		001001		
19	4011971-00	COUPLING	1			051899	
20	CSD2120-P	MOTOR DRIVER	1		001001		
21	M001790-06	SPACER	4		001001		

機械番号100001からのパーツです。

This figure shows parts for machines whose serial numbers are 100001 or above.

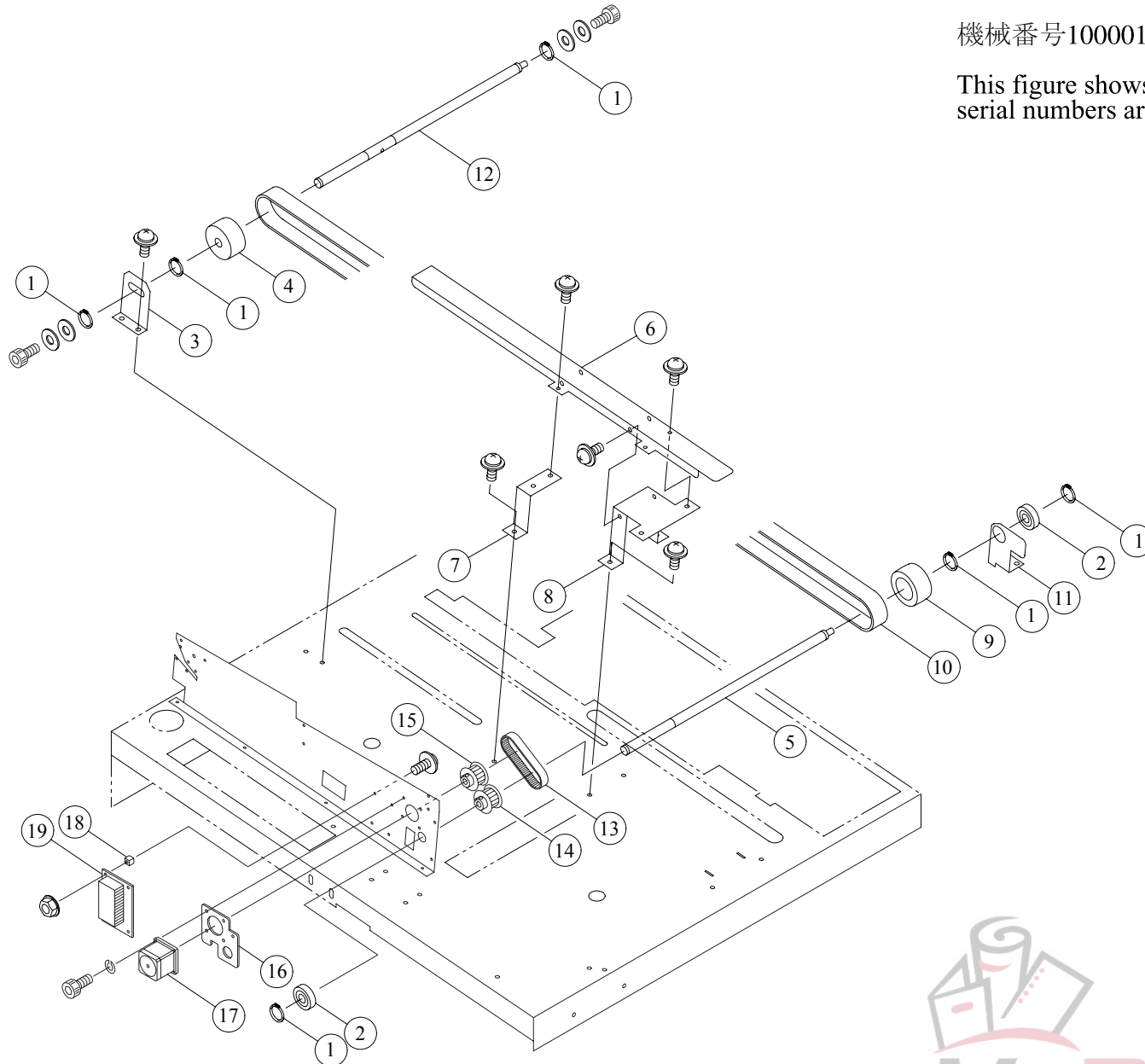

INDEX	Parts No.	Description	Qty	Price	S/N From	To	Remarks
1	STW-12	SNAP RING	4		100001		
2	4000912-00	BEARING	2		100001		
3	M041554-20	BRACKET	1		100001		
4	M001852-04	IDLE PULLEY	1		100001		
5	M041551-70	DRIVE SHAFT	1		100001		
6	M041622-20	BELT SUPPORT	1		100001		
7	M041642-30	BRACKET(A)	1		100001		
8	M041643-30	BRACKET(B)	1		100001		
9	M041555-01	ROLLER SHAFT	1		100001		
10	M041606-00	BELT	1		100001		
11	M001870-01	PULLEY	3		100001		
12	M041644-31	BRACKET	1		100001		
13	4014591-00	TIMING BELT	1		101010		96XL037
14	M048800-02	TIMING PULLEY(S)	1		100001		@ 
15	M041700-00	MOTOR PULLEY	1		100001		
16	M041552-40	MOTOR BASE	1		100001		
17	PK268-02A	MOTOR	1		100001		
18	M001790-06	SPACER	1		100001		
19	CSD2120-P	MOTOR DRIVER	1		100001		