

# Standard PS-P61 Punch Stapler

## Service Manual



Provided By

**MyBinding.com**  
*When Image Matters.*

# SERVICE MANUAL

## *PS-P61 Punch Staple*

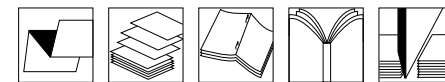

**Horizon**

HORIZON INTERNATIONAL, INC.

510 Kuze Ooyabu-cho Minami-ku, Kyoto 601-8206, Japan  
Phone:+81-75-934-6700, Fax:+81-75-934-6708, [www.horizon.co.jp](http://www.horizon.co.jp)

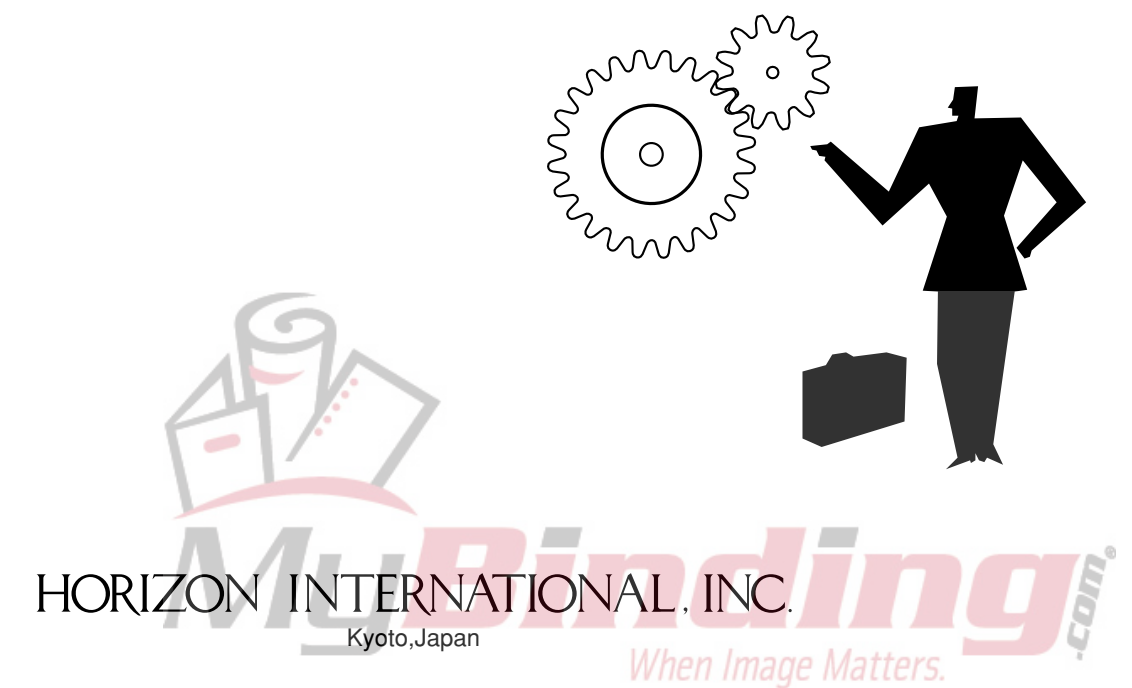

# **FOREWORD**

## **Punch Staple**

### **Model PS-P61**



This manual is designed to help you to keep the machine in a good operating condition. Read, study and keep this manual in a safe and convenient place.

Do not perform any maintenance until you read and understand the instructions in this manual.

If you have questions regarding maintenance or this publication, please contact our service division.

The machine design and specifications are subject to change without notice.

## **Safety Instruction**

1. Read and understand all safety instructions with a signal  **WARNING**, and  **CAUTION**. If safety instructions are ignored, personal injury will result.
2. HORIZON INTERNATIONAL INC. cannot anticipate every possible situation that might involve a potential hazard. The instruction in this manual are therefore not all inclusive.
3. Be sure to unplug the power cord when replacing the parts or repairing the machine.
4. Take care with the rotating parts when the machine is operated with the covers being opened.
5. Use the original HORIZON spare parts when replacing the parts.

# I Necessary Tool for Maintenance and Repair

Use the following tools for maintenance and repair.

- |    |                    |                                |        |         |
|----|--------------------|--------------------------------|--------|---------|
| 1. | Screw Driver       | No. 2                          |        |         |
| 2. | Screw Driver       | 6 to 7 mm                      |        |         |
| 3. | Allen Wrenches     | 1.5, 2, 2.5, 3, 4, 5, and 6 mm |        |         |
| 4. | Open-ended Wrench  | 5.5 x 7 mm                     | 8 x 10 | 13 x 17 |
| 5. | Box Wrench         | 5.5 mm                         |        |         |
| 6. | Snap-ring Expander |                                |        |         |

# II Signs and Abbreviations in This Manual

1. The following signs in this manual represent wire color.
2. The following abbreviations in this manual represent electronic and electrical parts.

Sign	Color
------	-------

<b>C</b>	<b>Brown</b>
<b>R</b>	<b>Red</b>
<b>O</b>	<b>Orange</b>
<b>Y</b>	<b>Yellow</b>
<b>G</b>	<b>Green</b>
<b>B</b>	<b>Blue</b>
<b>V</b>	<b>Violet</b>
<b>H</b>	<b>Gray</b>
<b>W</b>	<b>White</b>
<b>D</b>	<b>Black</b>
<b>S</b>	<b>Transparent</b>

Abbreviation	Meaning
--------------	---------

<b>CL</b>	<b>Clutch</b>
<b>BK</b>	<b>Brake</b>
<b>SW</b>	<b>Switch</b>
<b>mSW</b>	<b>Microswitch</b>
<b>M</b>	<b>Motor</b>
<b>LED</b>	<b>Light Emitted Diode</b>
<b>VR</b>	<b>Potentiometer</b>
<b>RY</b>	<b>Relay</b>

# Contents

<b>FOREWORD .....</b>	<b>I</b>
<b>Safety Instruction .....</b>	<b>II</b>
I Necessary Tool for Maintenance and Repair .....	III
II Signs and Abbreviations in this manual .....	III
<b>1. PS-P61 Specifications .....</b>	<b>1</b>
<b>2. Operation Overview .....</b>	<b>2</b>
<b>3. Sheet Flow .....</b>	<b>3</b>
<b>4. How to Remove Cover .....</b>	<b>4</b>
<b>5. Sensors and Electronic Parts Descriptions .....</b>	<b>5</b>
<b>6. Sensor Location and Descriptions .....</b>	<b>6</b>
<b>7. Transport Belt Drive Descriptions .....</b>	<b>7</b>
<b>8. Troubleshooting .....</b>	<b>8</b>
<b>9. LED and Connector Descriptions on P.C.B. ....</b>	<b>11</b>
<b>10. Power &amp; Signal Line Diagram .....</b>	<b>12</b>
<b>11. Panel Sensor Line Diagram .....</b>	<b>13</b>
<b>12. Staple Unit Inside Line Diagram .....</b>	<b>14</b>
<b>13. Power Supply Line Diagram .....</b>	<b>15</b>
<b>14. Punch Unit and Sensor .....</b>	<b>16</b>
<b>15. Timing Chart 1 .....</b>	<b>17</b>
<b>16. Timing Chart 2 .....</b>	<b>18</b>
<b>17. Timing Chart 3 .....</b>	<b>19</b>
<b>18. Check Mode .....</b>	<b>20</b>

---

# 1. PS-P61 Specifications

---

Product	Staple and Punch Unit for QC-P8/P10
Integrated Model	QC-P8, QC-P10
Jobs	A4 : Corner Staple, Top Staple, and other Side Corner Staple A3: Corner Staple NOTE - Only corner staple can be done with optional punch. - Two hole punch (option) can be performed only on A4 size.
Sheet Size with Operation Panel	A4 and A3 NOTE - Sheet size must be within +,-0.5 mm.
Sheet Size	Width : Maximum 298 mm (11.8") Minimum : 182 mm (7.2") Length : Maximum 432 mm (17") Minimum : 257 mm (10.2") NOTE - Other side corner staple and top staple are limited in size.
Sheet Quality	Normal Paper
Stapling and Punching Thickness	10 Sheets of 135 gsm (36# Bond)
Sheet Thickness	53 to 135 gsm (16# Bond to 36# Bond)
Optional Punch Capacity	Up to 105 gsm of normal paper
Production Speed	25 Sets/min. (Corner Staple) 15 Sets/min. (Top Staple, Other Side Corner Staple and Staple with Punch)
Transport Method	Connecting Section : Roller Transport Producing Section : Belts Transport
Detector	Sheet Jam, No Staple, Door, Staple Trouble, Punch Trouble, and Full Tray (LEDs illuminate on operation panel.)
Counter	4 digits (For Maintenance)
Drive	DC Motor : 3 x 24 V DC Solenoid : 4 x 24 V/35 W DC Motor : 1 x 24 V (with Punch)
Power	100 V 50/60 Hz, 115 V 60 Hz, 230 V 50 Hz
Power Consumption	150 W
Machine Dimensions (W x D x H)	Tray Open : 1,115 x 562 x 582 mm (43.9" x 22.2" x 22.9") Tray Close : 775 x 562 x 580 mm (30.6" x 22.2" x 22.9")
Machine Weight	77 kg (170 lb)

---

---

## 2. Operation Overview

---

1. Pile sheets into bins and turn on power switch.
  - Staple unit will be reset if staple unit is not at home position before power is on.
  - LED conditions of operation panel

Jog Guide	Illuminates at the current position. Not illuminates when irregular sheets are used.
Staple Mode	Illuminates at the angled side staple position.
Punch	Not illuminates.
Jog Time	1 time lamp illuminates.
2. Press option button on collator.
  - Option LED illuminates.
  - Gate in collator moves.
3. Set jog guides according to sheets.
  - LED in the selected sheet size illuminates.
4. Select required mode with staple mode button.
  - LED illuminates in different position as staple button is pressed.
  - Staple unit moves to set position a few seconds after staple mode is selected.

### NOTE

- **In the case of other side corner staple or top staple, staple mode cannot be selected because of limited sheet size.**
  - **In the case of staple with punch, staple mode cannot be selected because of limited sheet size.**
5. Set receiving tray and receiving tray guide according to sheet size.
  6. Press check button of collator twice. As collator starts, transport unit will transport a set of sheets. The set is stapled and/or punched and delivered to receiving tray.
  7. Press start button of collator. Collator starts collating and sets of sheets are produced. When miss/double or other troubles happen on collator, collating job stops with LED illuminated.

Collator's Error : Sheet jam, misfeed, and double feed are indicated on panel of collator.

PS-P61's Error : QC-P10 : Option error message is indicated on collator.

QC-P8 : Receiving tray lamp illuminates on collator.

PS-P61 : Monitor lamp illuminates.

8. When preset counter reaches to set number, collating stops and then transport unit stops.
  - In the case of the number of sets are not input in preset counter, collator stops because sheets run out, or because receiving tray of PS-P61 is full.



---

### 3. Sheet Flow

---

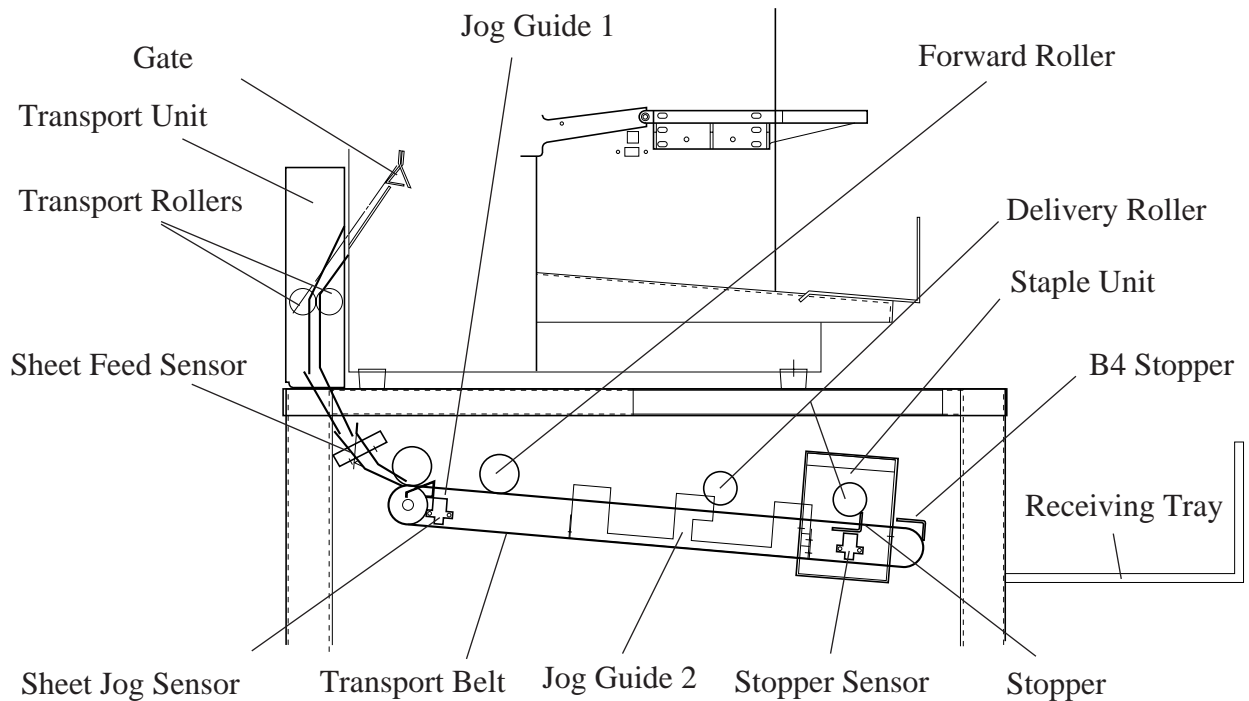

#### **A. Corner Staple with A4 and A3 Sheet Size (8.5" x 11"/11" x 17")**

1. A set of collated sheets are delivered to transport unit.
2. A set of sheets are transported by transport rollers and pass sheet feed detector.
3. Transport belt and forward roller transport a set of sheets to stopper.
4. Transport belt stops.
5. Jog solenoids is activated and jog sheets.
6. Stapler staples sheets.
7. Delivery roller lowers and transport belt delivers a set of sheets to receiving tray.

#### **B. Top Staple with A4 Sheet Size (8.5" x 11")**

Staple unit moves to top staple position and is ready to staple. The procedures 1 to 6 are the same as A.

7. Delivery roller lowers and transport belt delivers a set to the second staple position.
8. Jog solenoids is activated and jog sheets.
9. Stapler staples sheets.
10. Transport belt delivers a set of sheets to receiving tray.

#### **C. Other Side Corner Staple with A4 Sheet Size (8.5" x 11")**

Staple unit moves to the other side corner staple position and is ready to staple. The rest procedures are the same as A.

#### **D. Punch**

The procedures 1 to 6 are the same as A.

7. Punch punches sheets.
8. Delivery roller lowers and transport belt delivers a set to receiving tray.

---

## 4. How to Remove Cover

---

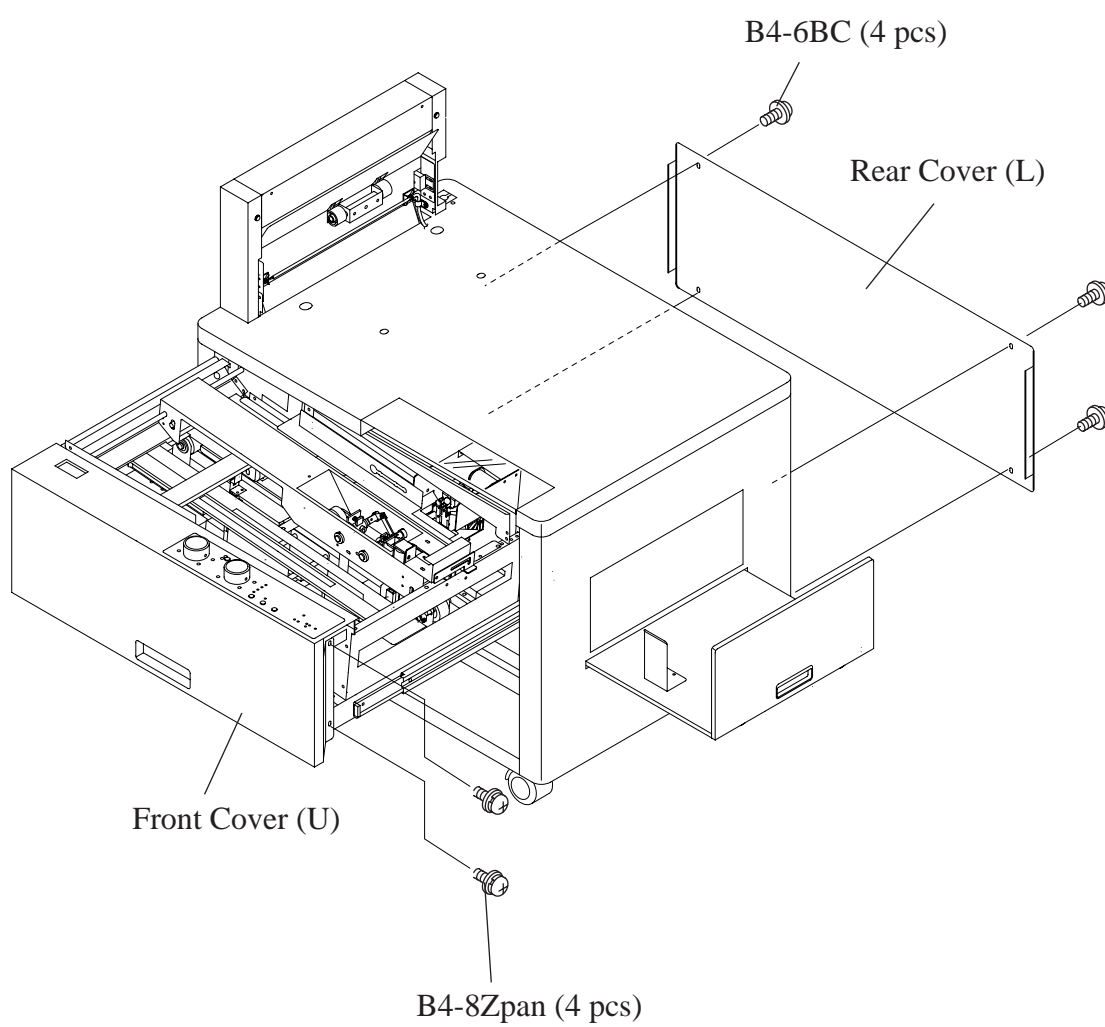

## 5. Sensors and Electronic Parts Descriptions

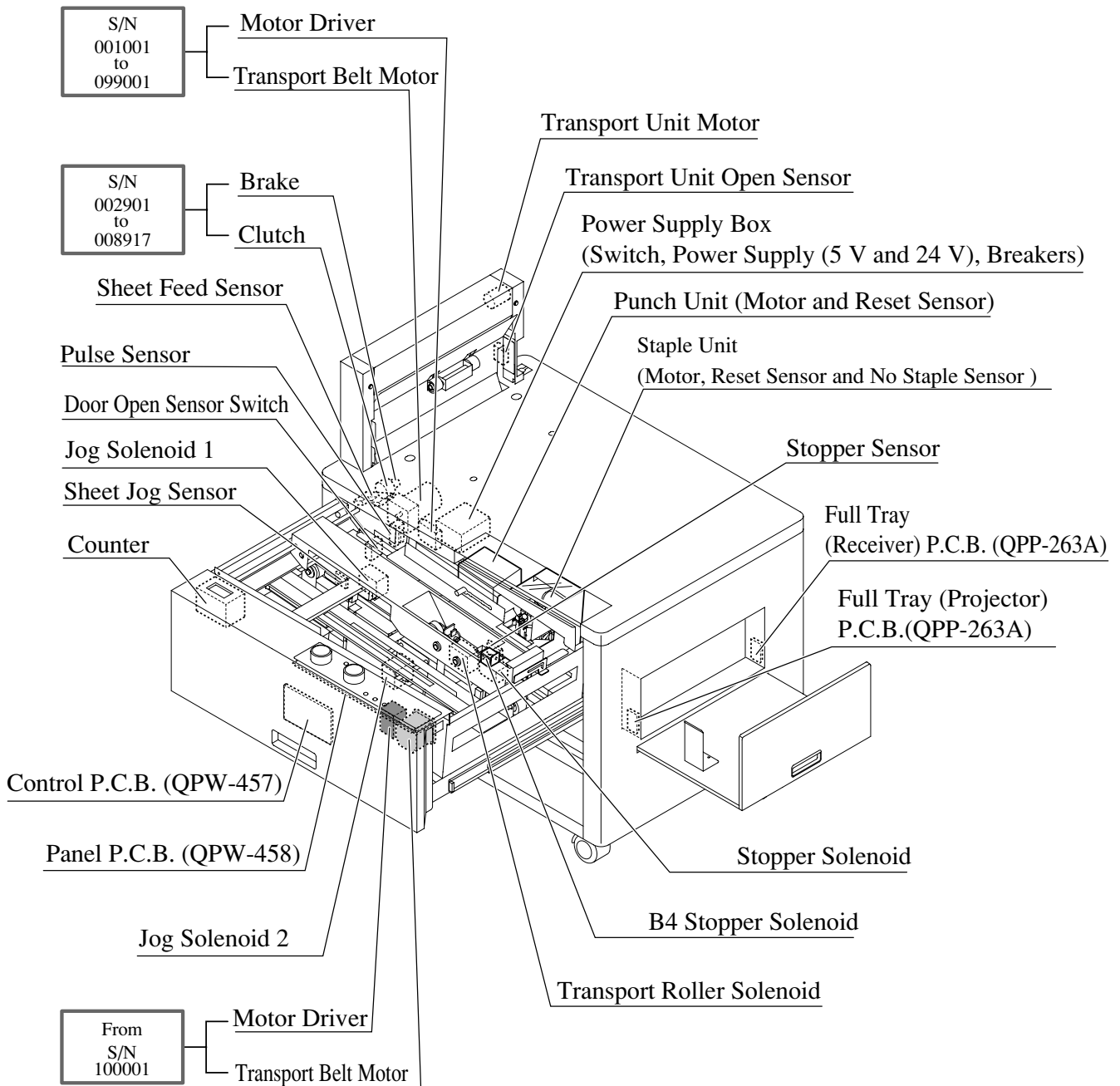

---

## 6. Sensor Location and Descriptions

---

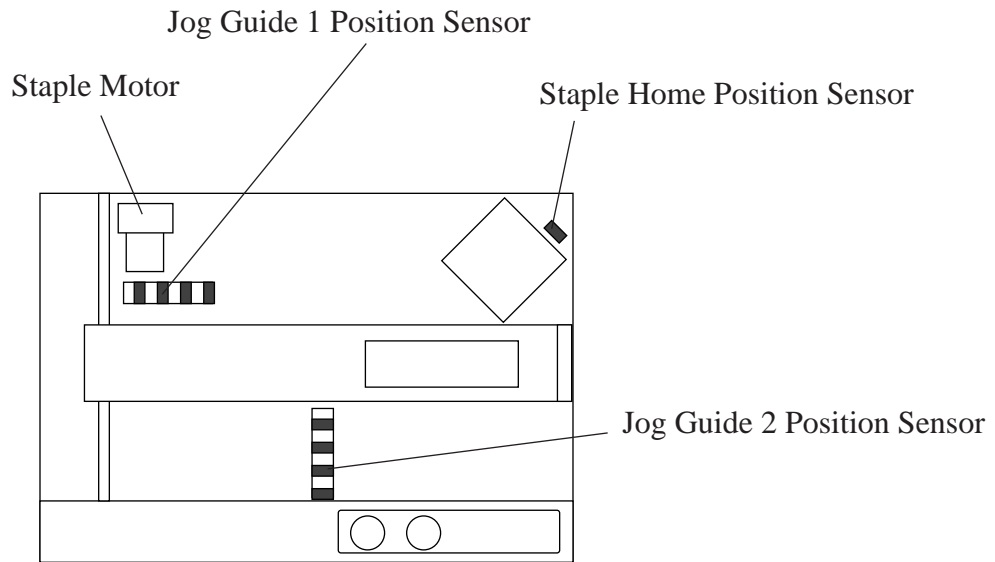

**Sketch of Staple Cabinet**

---

## 7. Transport Belt Drive Descriptions

---

(1) Applied Serial Number : S/N from 002901 to 008917

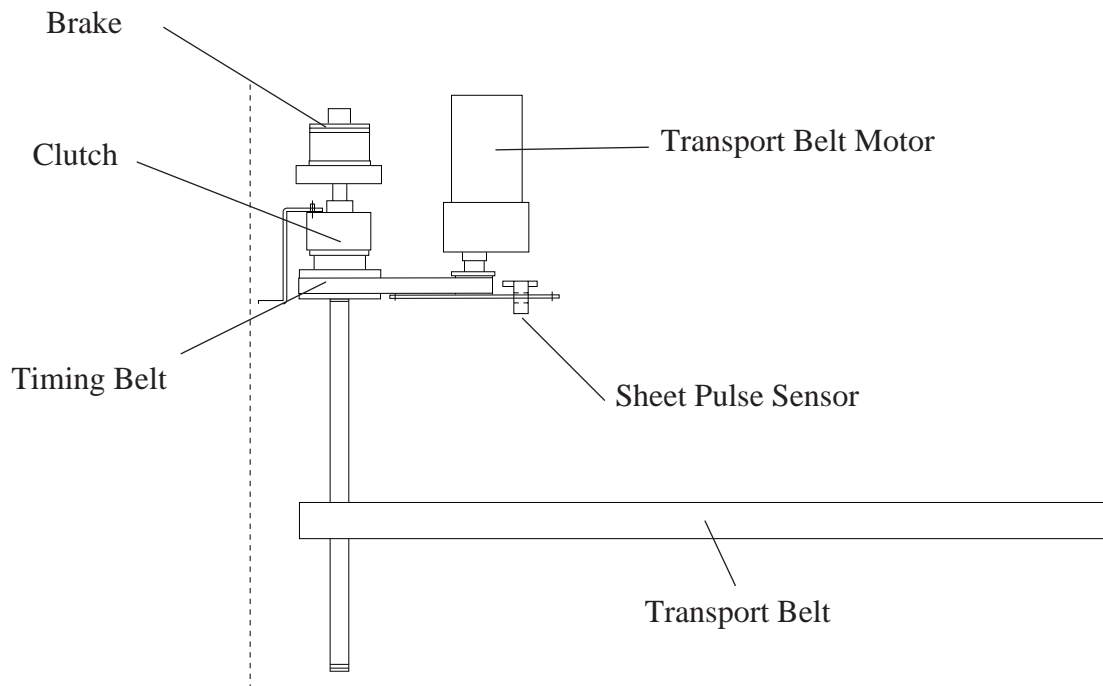

**Sketch of Inside of Staple Unit**

(2) Applied Serial Number : S/N 001001 or up

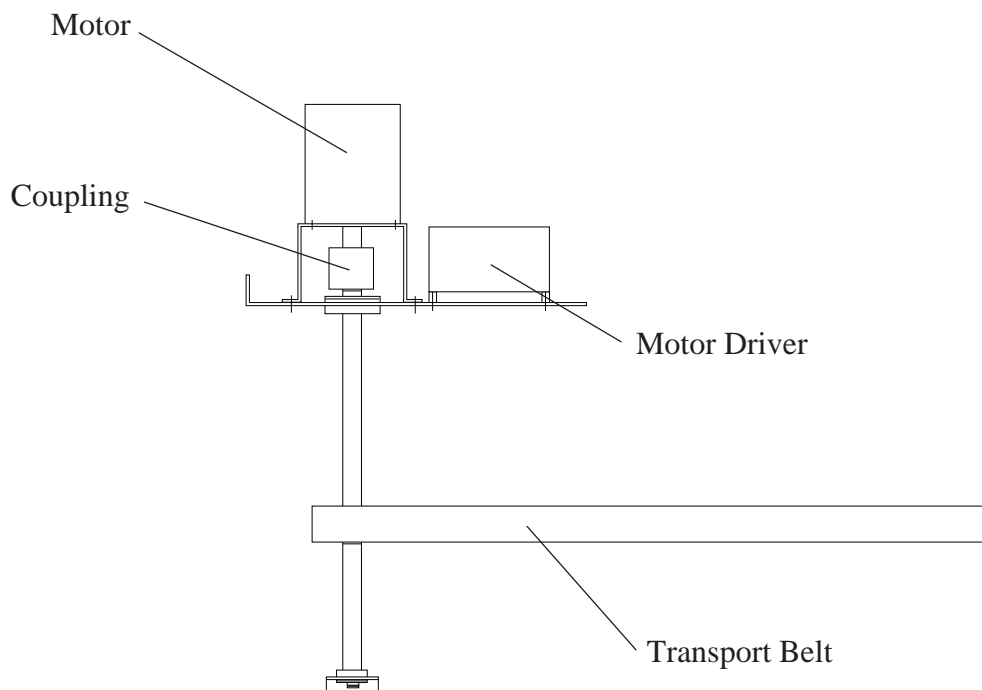

---

## 8. Troubleshooting

---

### A. Staple position (top staple) varies by more than 10 mm.

<p><b>(Cause)</b> Delivery roller does not lower enough and not deliver a set of sheets. Transport belt is dirty. Clearance between clutch and brake gets wider.</p>	<p><b>(Remedy 1)</b> Adjust delivery roller so that it lowers enough. - Adjust solenoid so that delivery roller touches transport belt and spring is compressed about 1 mm when solenoid activates.</p> <p><b>(Remedy 2)</b> Clean transport belt with alcohol soaked cloth.</p> <p><b>(Remedy 3)</b> Check the clearance between clutch and brake. Standard clearance is 0.15 (+,-0.05) in both clutch and brake. Applied Serial Number : S/N from 002901 to 008917</p>
--	--

### B. When sheet jam 1 lamp illuminates.

<p><b>(Cause)</b> Sheets are jammed in transport unit or transport unit is open.</p>	<p><b>(Remedy)</b> Open transport unit and remove jammed sheets. And close transport unit firmly.</p>
--	---

### C. When sheet jam 2 lamp/ sheet jam 3 lamp illuminates.

<p><b>(Cause)</b> Sheets are jammed in staple cabinet.</p>	<p><b>(Remedy 1)</b> Press eject button.</p> <p><b>(Remedy 2)</b> Pull out staple cabinet and remove jammed sheets. In the case sheet jam 3 lamp illuminates, lift support guide unit and remove jammed sheets.</p>
--	---

### D. When punch trouble lamp flashes.

<p><b>(Cause)</b> Punch unit is locked. <u>Attention</u> Punch Capability: up to 10 sheets of 105 gsm normal paper.</p>	<p><b>(Remedy)</b> Turn off power switch of collator, then turn on again after a few seconds. Press eject button, open staple cabinet and remove jammed sheets.</p>
---	---

---

## 8. Troubleshooting

---

### E. When no staple/staple trouble lamp illuminates.

<b>(Cause 1)</b> Out of staples.	<b>(Remedy 1)</b> Refill staples.
<b>(Cause 2)</b> Staple unit head is not set on the proper position.	<b>(Remedy 2)</b> Press eject button to reset staple unit.

### F. When no staple/staple trouble lamp flashes.

<b>(Cause)</b> Staple unit is locked because of staple jam.	<b>(Remedy)</b> Turn off power switch of collator, then open staple cabinet and remove jammed sheets or staples. Close staple cabinet, turn on power switch of collator and press eject button. Staple unit will be reset. Check for proper stapling by collating several sets (7 to 8 sets).
--	--

### G. When door lamp illuminates.

<b>(Cause)</b> Staple cabinet or rear cover is open.	<b>(Remedy)</b> Close staple cabinet or rear cover.
---	--

### H. When receiving tray lamp illuminates.

<b>(Cause)</b> Receiving tray is full, or sheets are not delivered completely.	<b>(Remedy)</b> Remove sheets from receiving tray, or delivery area.
---	---

### I. When sheets are delivered without stapling. (Collating Continues.)

<b>(Cause)</b> Staples are not fed to stapling position in staple unit.	<b>(Remedy 1)</b> Set unnecessary sheets on bin, and check for proper stapling by collating several sets (7 to 8 sets).  <b>(Remedy 2)</b> Open staple unit, pull up and release staple cartridge and clean staple feed roller with alcoholic soaked cloth.
--	---

---

## 8. Troubleshooting

---

### J. When sheets are delivered without stapling. (Collating stops.)

<p><b>(Cause)</b> Collated sheets are not jogged neatly.</p>	<p><b>(Remedy 1)</b> Open staple cabinet and check whether jog guide is positioned to sheet size properly.</p> <p><b>(Remedy 2)</b> Straighten curled sheets, and fan them well.</p> <p><b>(Remedy 3)</b> Press jog switch and select 2-time jog.</p>
--	---

### K. When circuit breaker trips.

	<p><b>(Remedy)</b> Turn off power switch of collator. Check inside of collator for obvious problems such as jammed sheets. If there is a problem, remove the cause. Reset circuit breaker a few minutes after turning off power switch. Push two left breakers to reset. Push up two right breakers to reset.</p>
--	---



## 9. LED and Connector Descriptions on P.C.B.

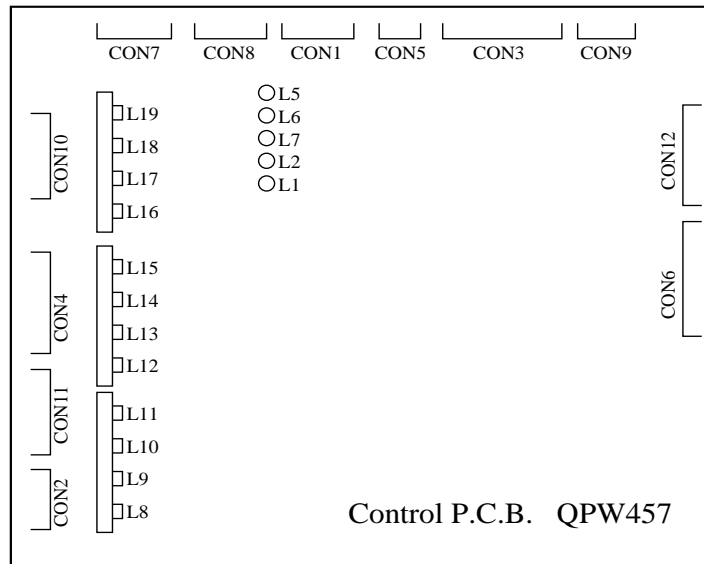

### LED Indication

L1	Staple Reset Position	Illuminates at the reset position.
L2	No Staple	Illuminates when staples remain in cartridge.
L5	Punch Home Position	Illuminates at the home position.
L6	No Starting PS-P61	Illuminates when PS-P61 cannot start.
L7	Staple/Punch	Illuminates when punch is selected.
L8	Staple Home Position	Illuminates at home position.
L9	Not Used	
L10	Transport Unit Open Sensor	Illuminates when transport unit is closed.
L11	Not Used	
L12	Sheet Feed Sensor	Illuminates when no sheets under sensor.
L13	Sheet Jog Sensor	Illuminates when no sheets over sensor.
L14	Stopper Sensor	Illuminates when no sheets over stopper.
L15	Staple Cabinet Rear Cover Open	Illuminates when cover is open.
L16	Staple Mode Button	Illuminates when button is pressed.
L17	Eject Button	Illuminates when button is pressed.
L18	Jog Button	Illuminates when button is pressed.
L19	Punch Button	Illuminates when button is pressed.

### Connector

CON1	To Staple Unit	CON7	To Punch Unit
CON2	To Sheet Size Sensor and Panel P.C.B.	CON8	To Connector which connects Collator
CON3	To Solenoids and Transport Motor	CON9	To Power Supply 5V 24V
CON4	To Sensors	CON10	To Panel P.C.B Switch
CON5	To Transport Roller Solenoid and B4 Stopper	CON11	To Sensors
CON6	To Indicate Panel P.C.B LED	CON12	To Staple Motor, Clutch, Blake and Pulse Sensor

# 10. Power & Signal Line Diagram

Applied Serial Number :  
S/N from 002901 to 008917

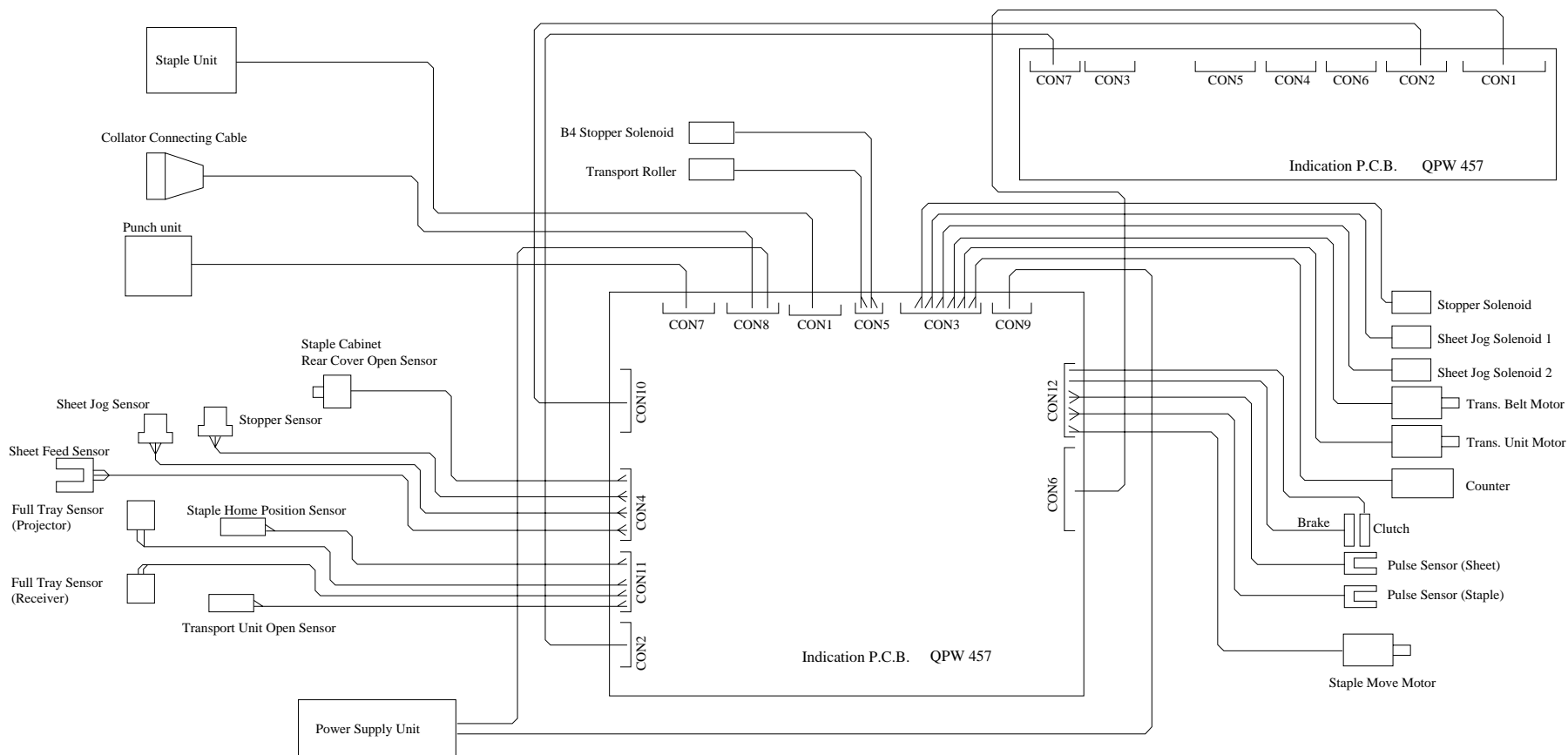

# 11. Power & Signal Line Diagram

Applied Serial Number :  
S/N 001001 or up

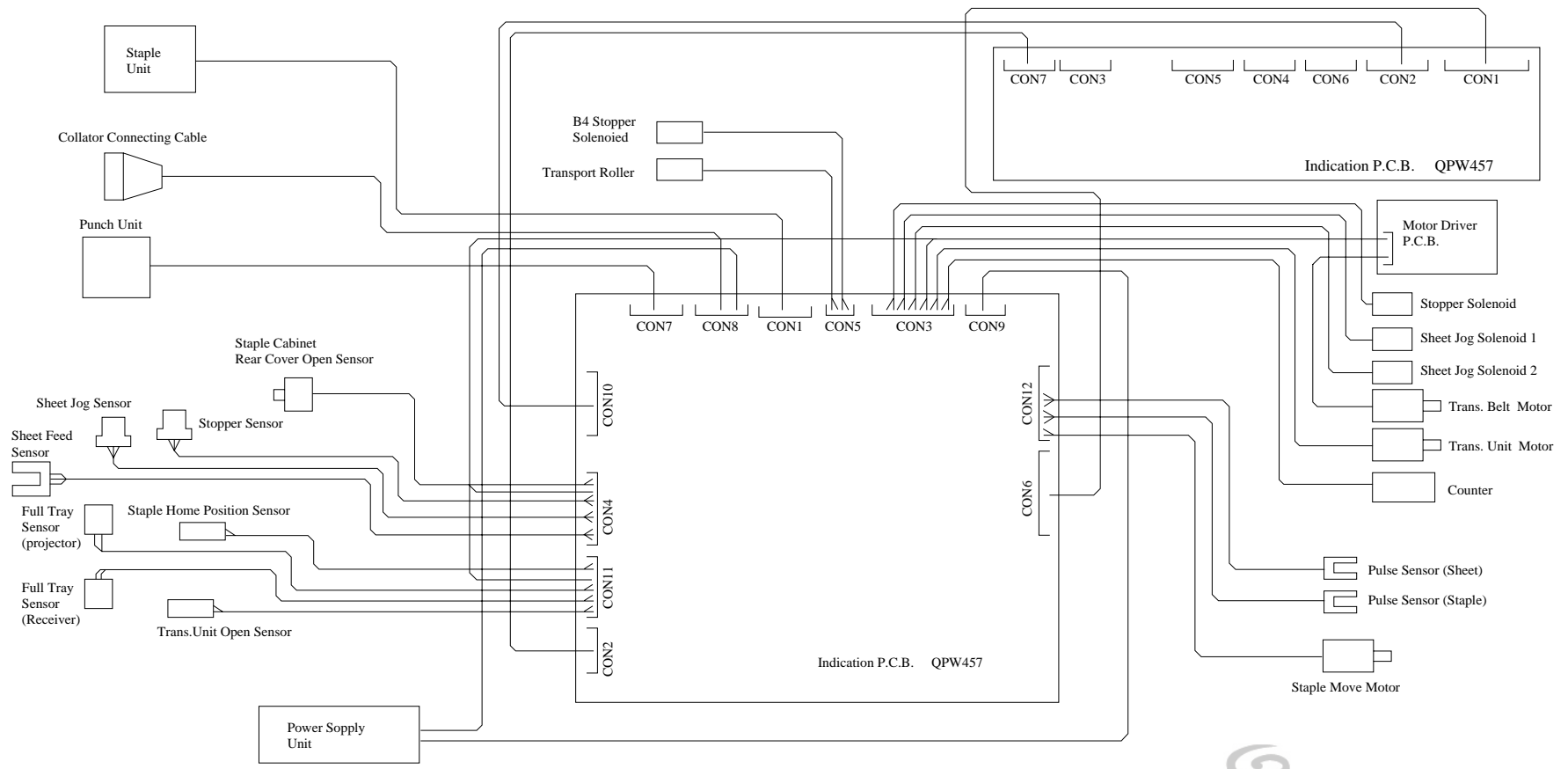

# 12. Panel Sensor Line Diagram

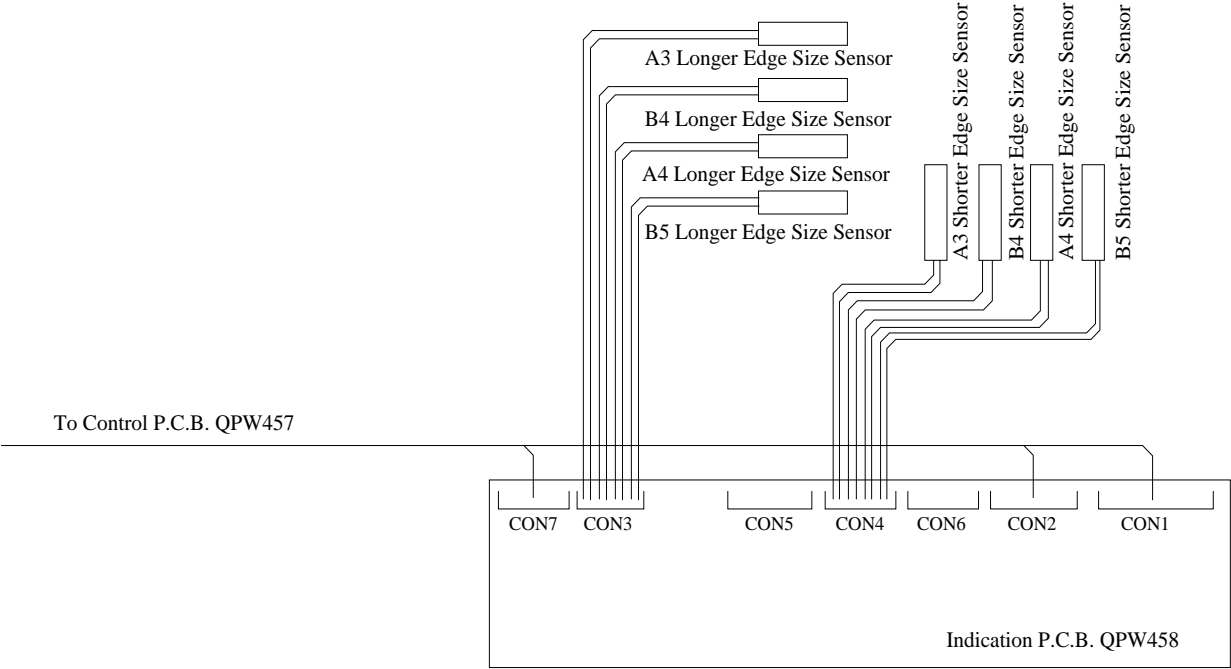

## 13. Staple Unit Inside Line Diagram

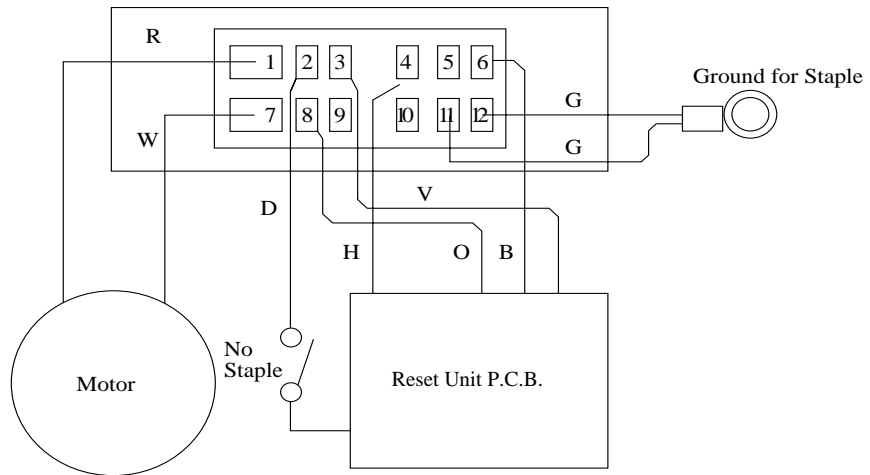

← View from Arrow Mark (Leading Cable)

Side View of Staple Unit

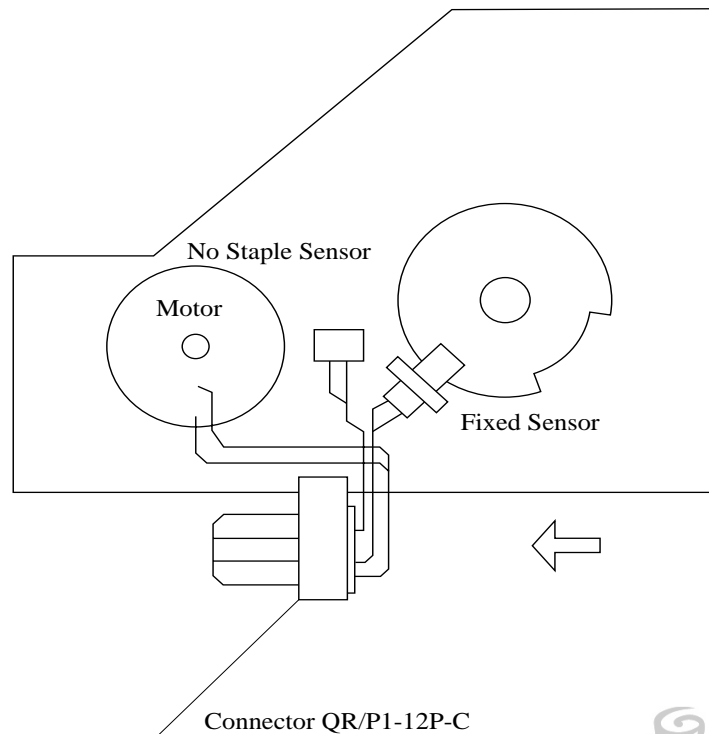

# 14. Transport Belt Motor Driver Wiring

Applied Serial Number : S/N 001001 or up

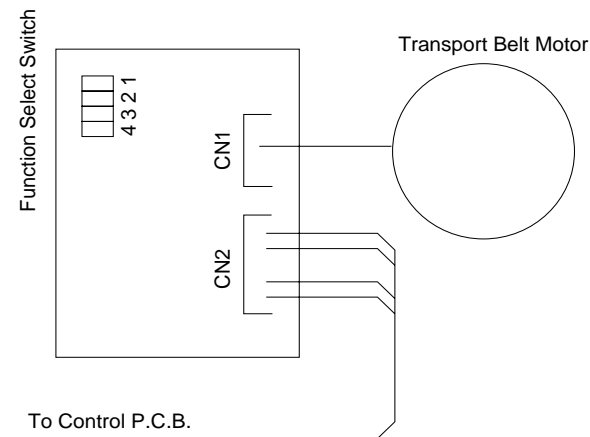

CN1	CN2	
	S/N099999 or before	S/N100001 or after
To Transport Belt	To Motor	To Control P.C.B.
1 Green	1 To Connector 4-10	None
2 Black	2 To Connector 3-10	None
3 Blue	3 None	To Connector 4-10
4 Red	4 None	To Connector 3-10
5 Yellow	5 None	None
6 White	6 None	None
	7 None	None
	8 None	None
	9 None	None
	10 None	None
	11 To Connector 3-9	To Connector 3-9
	12 To Connector 11-4	To Connector 11-4

The following list is shown the function select switch position in normal operation condition.

The machines having S/N 007006 or up equip with ver. 3.03 rom.

Function Select Switch	ROM Version			
	3.00		3.03	3.20
	Normal Position	Another Position	Normal Position	Normal Position
1. Automatic Current Reducing Function	ON	OFF	ON	ON
2. Step Select Switch	ON 1.8°	OFF 0.9°/stp	OFF	OFF
3. Input Pulse Select Switch	OFF 2 pulse	ON 1 pulse	OFF	OFF
4. Power Voltage Select Switch	ON 24 V	OFF 36 V	ON	ON

# 15. Power Supply Line Diagram

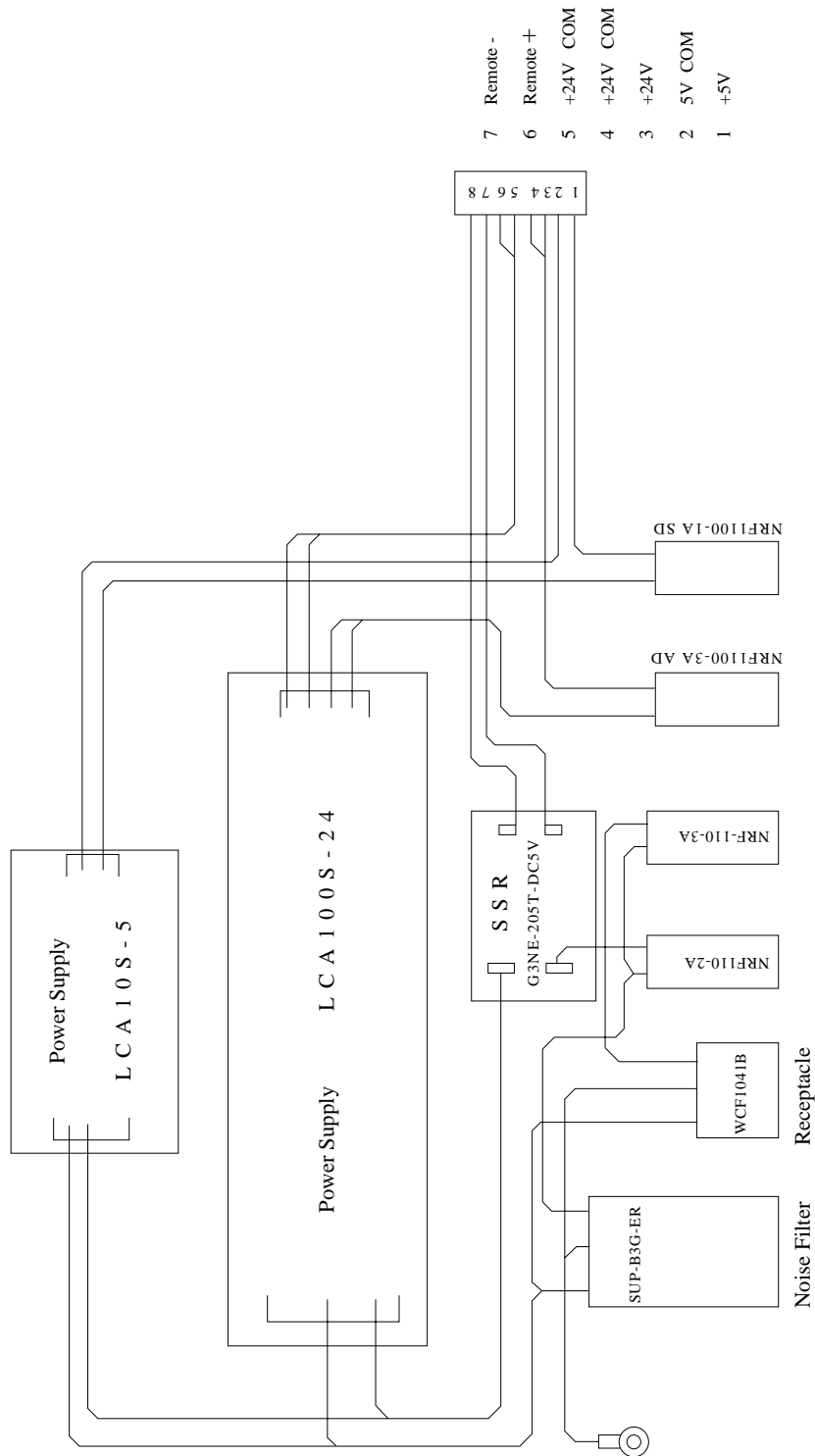

# 16. Punch Unit and Sensor

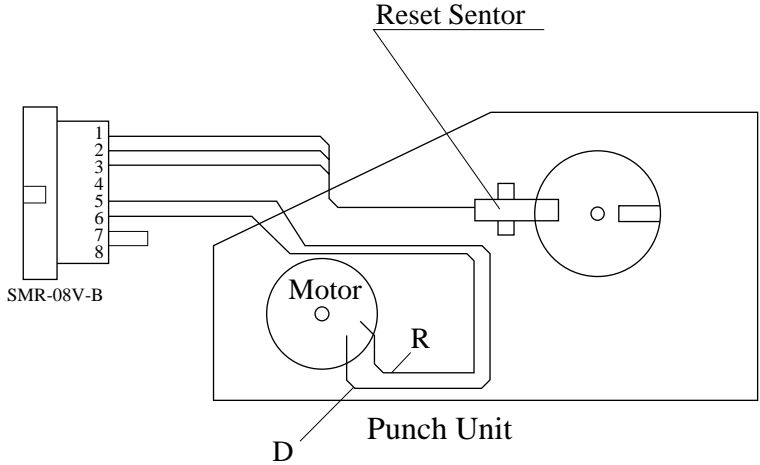





# 18. Timing Chart 2

(Applied Serial Number : S/N from 002901 to 008917)

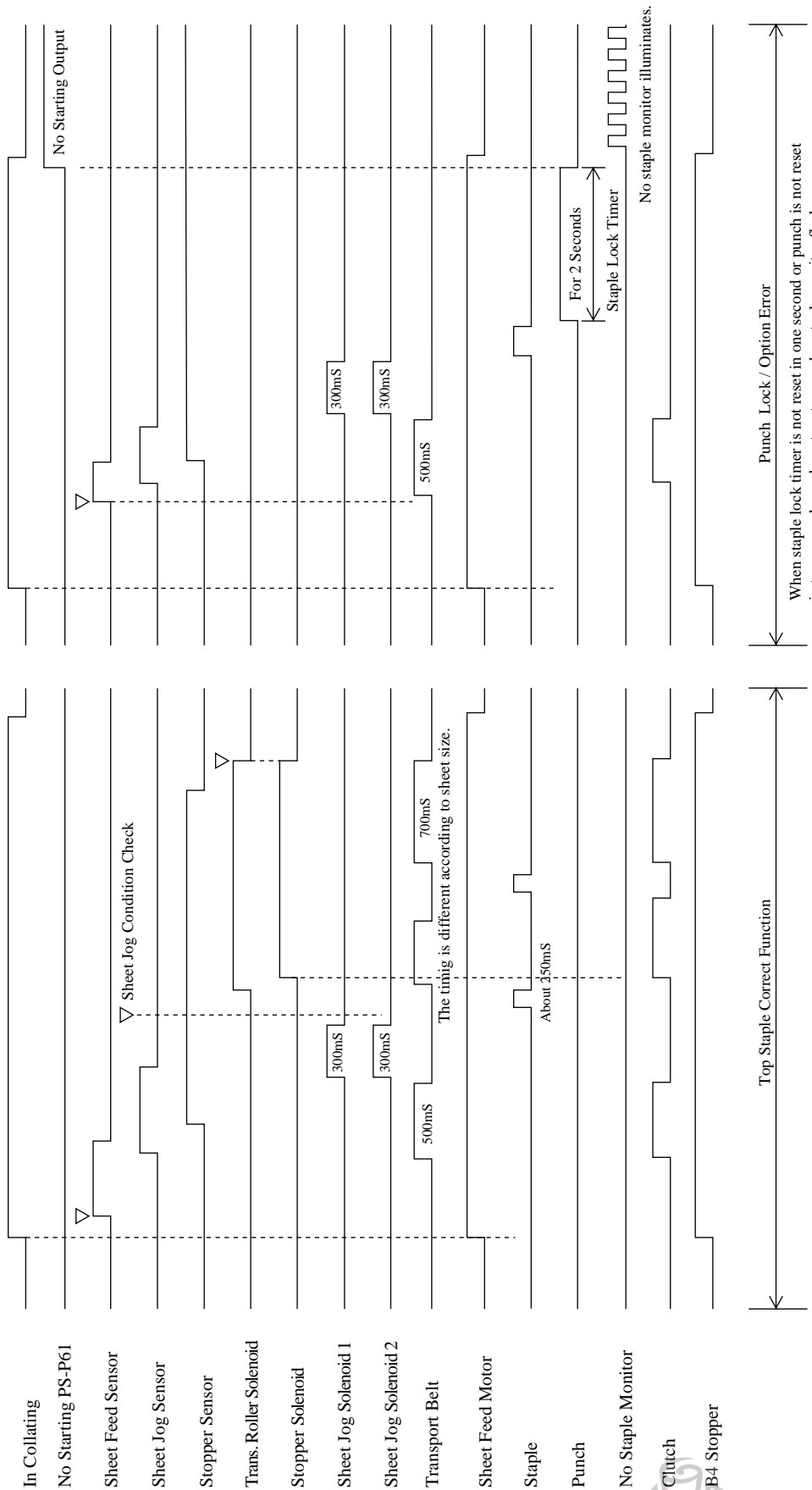

# 19. Timing Chart 2

( Applied Serial Number : S/N 001001 or up )

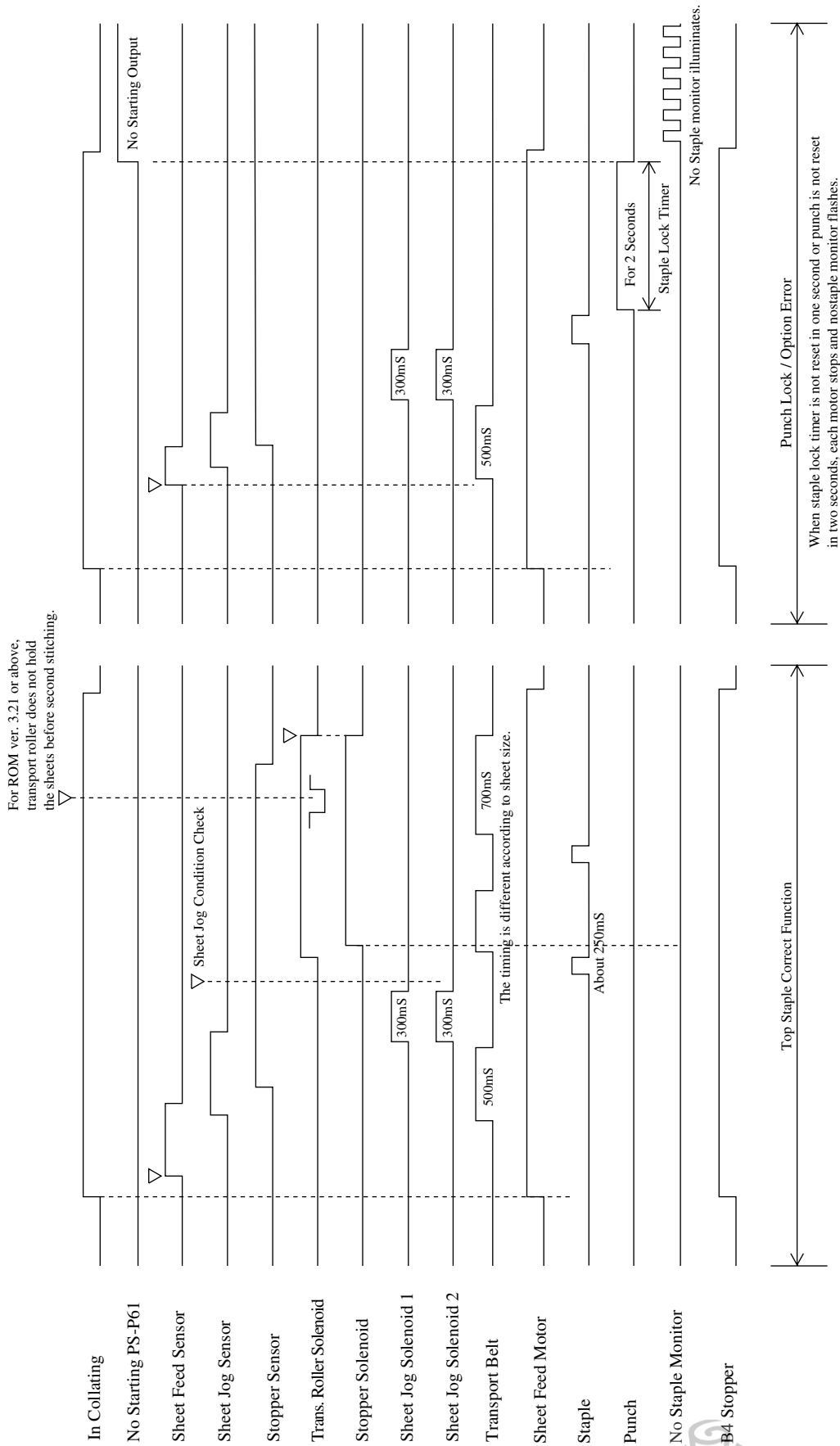

When staple lock timer is not reset in one second or punch is not reset in two seconds, each motor stops and nostaple monitor flashes.



## 20. Timing Chart 3

(Applied Serial Number : S/N from 002901 to 008917)

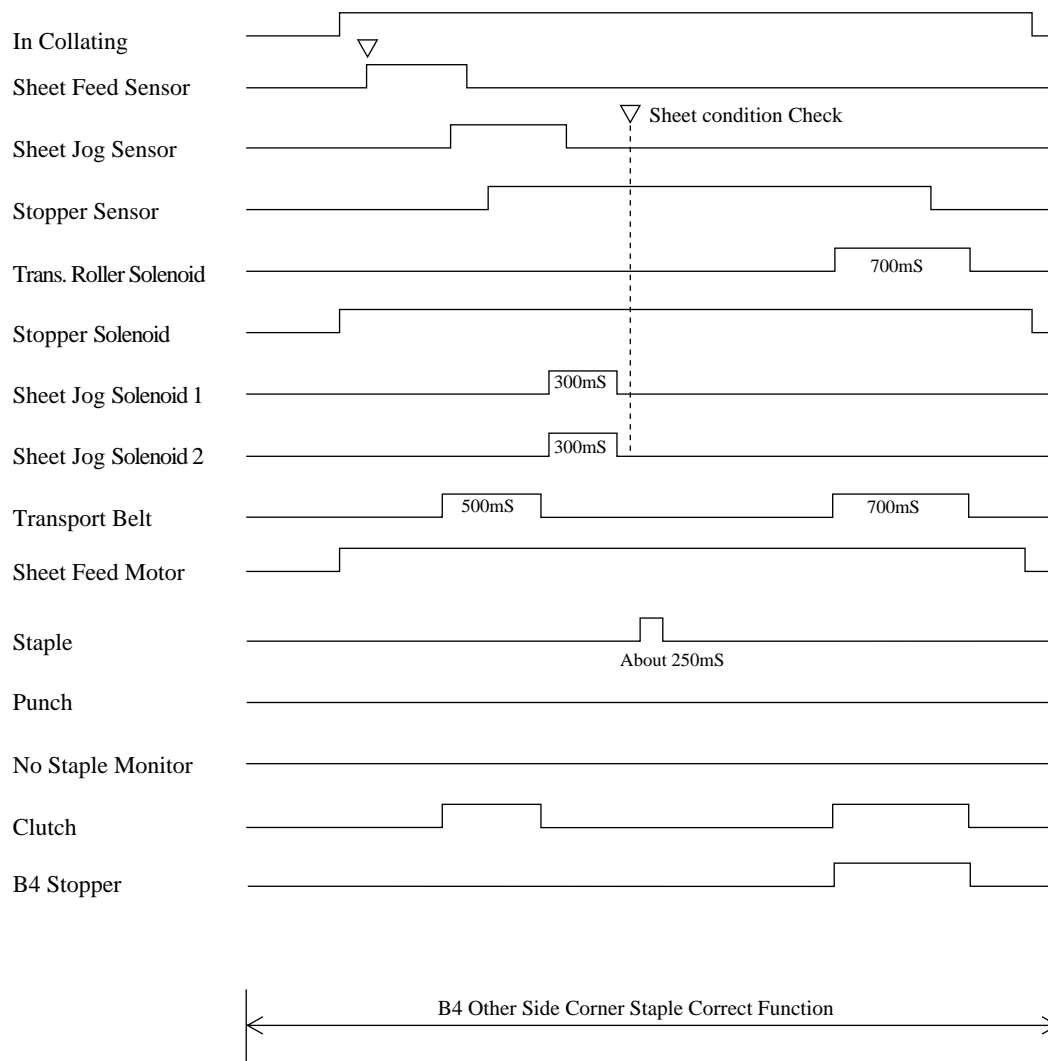

## 21. Timing Chart 3

(Applied Serial Number : S/N 001001 or up )

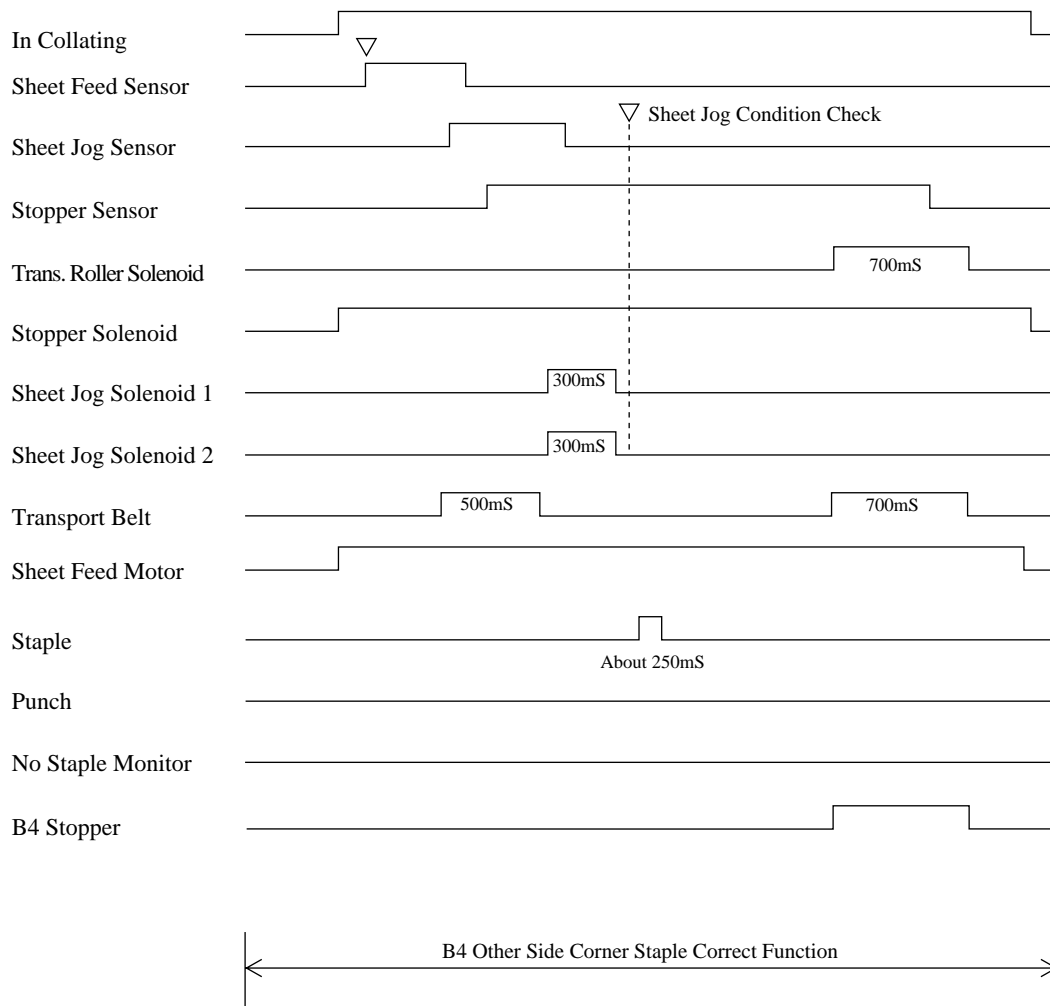

---

## 22. Check Mode

---

### 1. Staple Unit Check Mode

- Turn on power with eject button pressed.
- Every time eject button is pressed, staple works.
- Lock sensor works during check mode. If staple lock continues for more than 1 second, staple motor stops and staple trouble lamp on monitor flashes

### 2. Punch Unit Check Mode

- Turn on power with eject button pressed.
- Press staple mode switch to select "corner staple 0°".
- Every time eject button is pressed, punch works.

#### NOTE

**- Operate punch unit with 3 to 4 seconds intervals. Otherwise, motor or controller may be broken. Lock sensor works during check mode. If punch lock continues for more than 2 seconds, punch motor stops and punch trouble lamp on monitor flashes.**

### 3. Check on Complete Functions

- Turn on power with staple mode button and eject button pressed at the same time. And complete function of PS-P61 will work successively except punch.

#### NOTE

**- Operating PS-P61 with staple cartridge in check mode may cause staple jam. When operating in check mode, remove staple cartridge or insert sheets into staple section.**

**- When each of monitor lamp flashes, PS-P61 does not work. Turn off power and turn on again.**

**- Check mode does not reset until power is turned off. Turn on again when collating job is started.**