

Tamerica TW3100

3:1 Pitch Twin Loop Wire

Binding Machine

Instruction Manual



Provided by

MyBinding.com
When Image Matters.

Call Us at 1-800-944-4573

- 1** 1. Install two handles from right side and attach handle onto master shaft. Then insert knob set and tighten the handle.

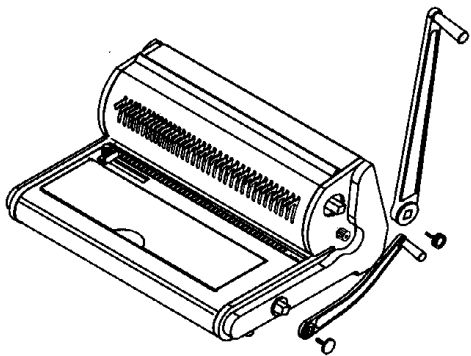

- 3** 1. Adjust side guide.
2. Pull set pin out to cancel this die if you find edge of document partially covers one of white rectangles on the alignment scale.
3. Adjust knob for binding depth to 1.2.3 or 4

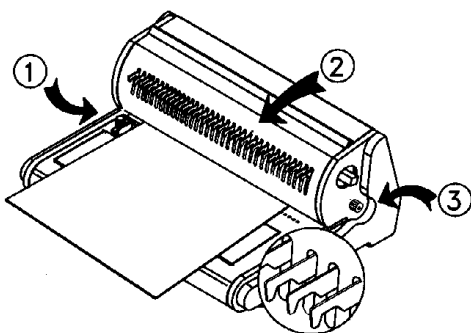

- 5** 1. Select the wire size, according to the number of sheets.
2. Open the clamp and place the wire with narrow side out onto the clamp.

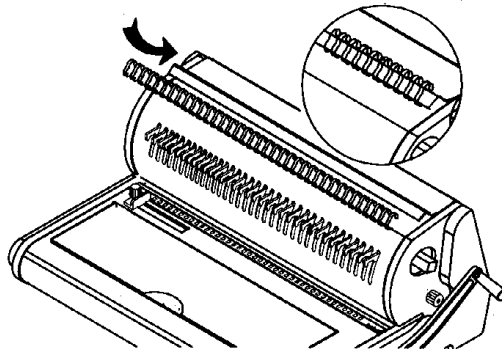

- 7** 1. Open the front plastic cover.
2. Adjust the wire closer to the size of wire being used by sliding the knob.

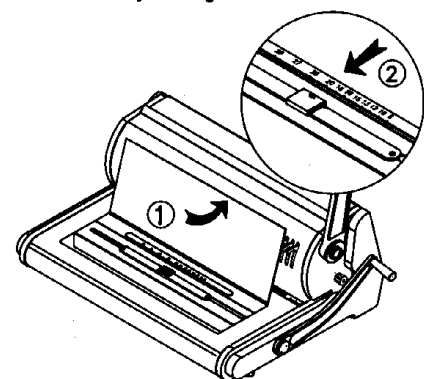

- 2** Measure the thickness of paper to be bound and determine punching depth by using binding gauge. Select correct diameter of binding wire to use.

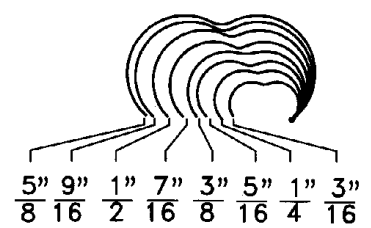

- 4** 1. Insert paper into punch throat.
2. Pull handle down to punch. Return handle to upright and pull paper out.
3. Continue this step until all sheets are punched.

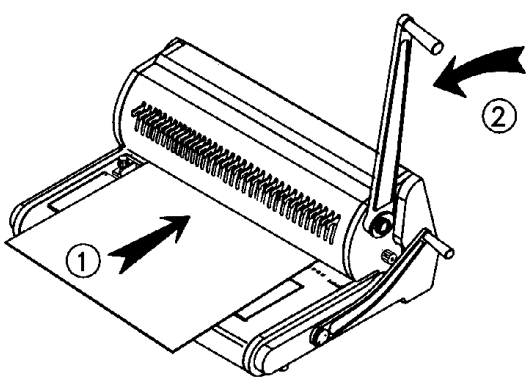

- 6** 1. Remove the punched paper and insert the exposed wire fingers into the punched holes.

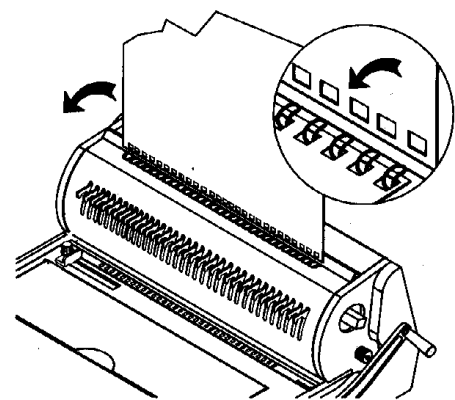

- 8** 1. Place the assembled book into the open wire closer bars.
2. Pull the closing handle to close the wire into the punched sheets.

